

**CATALOGO PARTI DI RICAMBIO - PARTS CATALOG  
CATALOGUE PIECES DE RECHANGE - ERSATZTEILKATALOG  
CATALOGO PIEZAS DE REPUESTO**

 **Husqvarna**



***TC-TE 250-450-510,  
SMR 400-450-510 / 2006***

**Part. N° 8000 A5912**

**INFORMAZIONI GENERALI**

Il presente catalogo serve per richiedere con esattezza le parti di ricambio  
Nelle ordinazioni indicare:

- 1) il numero di codice dei particolari seguito dalla descrizione;
  - 2) il colore per i pezzi verniciati o comunque colorati;
  - 3) il numero di matricola del motociclo, stampigliato sul canotto di sterzo.
- Le indicazioni destra e sinistra si riferiscono ai lati del veicolo rispetto al senso di marcia.

**GENERAL INFORMATION**

The present spare parts list enables one to order exactly the right spare parts.

When ordering specify:

- 1) the part's code number followed by its description;
  - 2) indicate colour for painted or coloured parts;
  - 3) the motorcycle's serial number, stamped on the steering head.
- References to right and left apply to the vehicle in terms of its direction of movement.

**INFORMATIONS GENERALES**

Ca catalogue permet de commander correctement les pièces de rechange.  
Les commandes doivent être passées en indiquant:

- 1) le numéro de code des pièces détachées suivi de leur description;
  - 2) le couleur des pièces peintes ou colorés;
  - 3) le matricule de la moto, estampillé sur la tige du guidon.
- Droite et gauche sont les côtés du véhicule par rapport au sens de la marche.

**ALLGEMEINE HINWEISE**

Dieser Ersatzteilkatalog dient zur genauen Angabe der Teile bei Ersatzteilbestellungen.

Bei Ersatzbestellung ist folgendes anzugeben:

- 1) Die Bestellnummer der Ersatzteile mit der entsprechenden Beschreibung;
  - 2) Farbe für lackierte und farbige Teile angeben;
  - 3) Die Sseriennummer des Motorrads, die am Lenkrohr eingepreßt ist.
- Die Angaben rechts und links beziehen sich auf das Fahrzeug in Fahrrichtung.

**INFORMACIONES GENERALES**

El presente catálogo sirve para pedir con exactitud las partes de recambio.  
En los pedidos se debe indicar:

- 1) el número de código de la parte y a continuación la descripción;
  - 2) el color para las piezas barnizadas o coloreadas;
  - 3) el número de matrícula de la motocicleta, estampado en el tubo de dirección.
- Las indicaciones derecha e izquierda se refieren a los lados del vehículo respecto del sentido de marcha.

**NOTE - LIST - NOTES - NOTE - NOTAS:**

- A** : In alternativa - In alternative - En alternative  
Wahlweise - En alternativa
- C** : Modello **TC** - **TC** model - Modèle **TC** - Modell **TC** - Modélo **TC**
- D** : In dotazione - To issue - En necessaire  
Ausrustungsteile - En dotaciòn
- E** : Ad esaurimento - To fell out - A' finir - Erschöpfung - A agotamiento
- F** : Fornire assieme - Supply unitedly - Fournir ensemble  
Wird zusammen geliefert - Equipar juntos
- M** : Modello **SMR** - **SMR** model - Modèle **SMR** - Modell **SMR** - Modélo **SMR**
- N** : Non fornito - Not supplied - Ne pas fournit  
Keine Gelieferende - No equiparado
- Ø** : Non per JPN - Not for JPN - Ne pas pour JPN  
Keine für JPN - No por JPN
- P** : Non per SMR - Not for SMR - Ne pas pour SMR  
Keine für SMR - No por SMR
- Q** : Solo per SMR / U.S.A. - Only for SMR / U.S.A. -  
Soulement pour SMR / U.S.A.  
Nur für SMR / U.S.A. - Solo por SMR / U.S.A.
- R** : A richiesta - Upon request - Sur demande - Auf anfrage - Bajo pedido
- S** : Di serie - Supplied - De série - Standard - De serie
- U** : Solo per TE/ U.S.A. - Only for TE/ U.S.A. -  
Soulement pour TE/ U.S.A.  
Nur für TE/ U.S.A. - Solo por TE/ U.S.A.
- X** : Non per U.S.A. - Not for U.S.A. - Ne pas pour U.S.A.  
Keine für U.S.A. - No por U.S.A.
- XB** : Non per BR - Not for BR - Ne pas pour BR  
Keine für BR - No por BR
- Y** : Non per TC - Not for TC - Ne pas pour TC - Keine für TC - No por TC
- ¥** : Solo per SMR 400 - Only for SMR 400 - Soulement pour SMR 400  
Nur für SMR 400 - Solo por SMR 400
- W** : Modello **TE** - **TE** model - Modèle **TE** - Modell **TE** - Modélo **TE**
- Z** : n° denti, number of teeth, numéro dents, Zähne nummer  
número dientes
- A** : Austria, Austria, Autriche, Österreich, Austria
- AUS** : Australia, Australia, Australie, Australien, Australia
- B** : Belgio, Belgium, Belgique, Belgien, Belgica
- BR** : Brasile, Brazil, Brasile, Brasilien, Brasil
- CDN** : Canada, Canada, Canada, Kanada, Canadá
- CH** : Svizzera, Switzerland, Suisse, Schweizer, Suiza
- D** : Germania, Germany, Allemagne, Deutschland, Alemania
- E** : Spagna, Spain, Espagne, Spanien, España
- F** : Francia, France, France, Frankreich, Francia
- GB** : Gran Bretagna, Great Britain, Grand Bretagne  
Groos Britan, Gran Bretaña
- I** : Italia, Italy, Italie, Italien, Italia
- J** : Giappone, Japan, Japon, Japan, Japón
- SF** : Finlandia, Finald, Finlande, Finland, Finlandia
- USA** : Stati Uniti d'America, United States of America, Etats Units d'Amérique,  
Vereinigte Staaten von Amerika, Estados Unidos

N° DI MATRICOLA INIZIALE - INITIAL SERIAL NUMBER - MATRICULE INITIAL - BEGINNTESERIENNUMMER - MATRICULA INICIAL	
MODELLO - MODEL MODELE - MODELL MODELO	MATRICOLA - SERIAL NUMBER MATRICULE - SERIENNUMMER MATRICULA
TC 250/2006	ZCGH800AA5V052000
TC 450/2006	ZCGH802BA5V052000
TC 510/2006	ZCGH803CD5V052000
TE 250/2006	ZCGH800AC5V006000
TE 250/2006 USA	ZCGTE250#5V006000
TE 450/2006	ZCGH802BC5V006000
TE 450/2006 USA	ZCGTE450#5V006000
TE 510/2006	ZCGH803CA5V006000
TE 510/2006 USA	ZCGTE510#5V006000
SM 400R/2006	ZCGH801AD5V006000
SM 450R/2006	ZCGH802BD5V006000
SM 450R/2006 USA	ZCGSM450#5V006000
SM 510R/2006	ZCGH803CC5V006000
SM 510R/2006 USA	ZCGSM510#5V006000

Codice colore **E**: versione "GIALLO - BLU"  
Color code **E**: "YELLOW - BLUE" version  
Code couleur **E**: version "JAUNE - BLEU"  
Code Farbe **E**: "GELB - BLAU" Version  
Código de color **E**: moto "AMARILLO - AZUL"

Codice colore **G**: versione "ROSSO - BIANCO - NERO"  
Color code **G**: "RED - WHITE - BLACK" version  
Code couleur **G**: version "ROUGE - BLANC - NOIR"  
Code Farbe **G**: "ROT - WEISSE - SCHWARZ" Version  
Código de color **G**: moto "ROJO - BLANCO - NEGRO"

Dati indicativi soggetti a modifiche senza impegno di preavviso.  
All data are subject to modification without prior notice.  
Données indicatif sujet au modifications sans obligation de préavis.  
Anderungen Vorbehalten.  
Datos indicativos sujetos a modificaciones sin compromiso de preaviso.

Tavola Drawing Table Bild Tabla	Denominazione	Description	Designation	Bezeichnung	Denominacion	Pagina Page Page Seite Paja
1	ATTREZZI DI ASSISTENZA, MANUALI E CATALOGHI	SERVICE TOOLS, MANUALS AND CATALOGS	OUTILS D'ASSISTANCE, MANUELS ET CATALOGUES	HILFAUSRUSTUNG, HANDBUCH UND KATALOG	HERRAMIENTAS DE ASISTENCIA, MANUALESY CATALOGOS	15
2	KIT IN DOTAZIONE	EQUIPMENT KITS	KITS EN NECESSAIRE	AUSRÜDTUNGSTEILE KIT	KIT EN DOTACION	17
3	CILINDRO, PISTONE	CYLINDER, PISTON	CYLINDRE, PISTON	ZYLINDER, KOLBEN	CILINDRO, PISTON	21
4	TESTA CILINDRO	CYLINDER HEAD	CULASSE	ZYLINDERKOPF	CULATA	27
5	MANOVELLISMO	CRANKSHAFT	VILEBREQUIN	KURBELWELLE	CIGÜEÑAL	35
6	TRASMISSIONE PRIMARIA, FRIZIONE	PRIMARY DRIVE, CLUTCH	TRANSMISSION PRIMAIRE, EMBRAYAGE	PRIMÄRÜBERSETZUNG, KUPPLUNG	TRANSMISION PRIMARIA, EMBRAGUE	37
7	DISTRIBUZIONE	VALVE TIMING	DISTRIBUTION	VENTILSTEUERUNG	DISTRIBUCION	41
8	SEMICARTER SINISTRO	L.H. HALF CRANKCASE	CARTER G.	GEHAUSEDECKEL L.	BANCADA IZQ.	45
9	SEMICARTER DESTRO	R.H. HALF CRANKCASE	CARTER D.	GEHAUSEDECKEL R.	BANCADA DER.	49
10	COPERCHI SEMICARTER DX	R.H. HALF CRANKCASE COVERS	COUVERCLES CARTER D.	GEHAUSEDECKEL R.	TAPAS BANCADA DER.	53
11	COPERCHI SEMICARTER SX	L.H. HALF CRANKCASE COVERS	COUVERCLES CARTER G.	GEHAUSEDECKEL L.	TAPAS BANCADA IZQ.	55
12	LUBRIFICAZIONE	OIL PUMP	PUMPE HUILE	MOTORSCHMIERUNG	LUBRICACION	57
13	CARBURATORE KEIHIN (250-450-510)	CARBURETOR KEIHIN (250-450-510)	CARBURATEUR KEIHIN (250-450-510)	VERGASER KEIHIN (250-450-510)	CARBURADOR KEIHIN (250-450-510)	61
13A	CARBURATORE MIKUNI (400)	CARBURETOR MIKUNI (400)	CARBURATEUR MIKUNI (400)	VERGASER MIKUNI (400)	CARBURADOR MIKUNI (400)	67
14	PARTE ELETTRICA	IGNITION SYSTEM	PARTIES ELECTRIQUE	ELEKTRISCHE TEILE	PARTE ELECTRICA	69
15	AVVIAMENTO	STARTING	DEMARRAGE	ANLASSER	ARRANQUE	73
16	CAMBIO, COMANDO CAMBIO (TC)	TRANSMISSION, SHIFTER (TC)	BOITE DE VITESSE, COMMANDE DE VITESSE (TC)	WECHSELGETRIEBE, GANGSCHALTUNG (TC)	CAMBIO, MANDO CAMBIO (TC)	77
16A	CAMBIO, COMANDO CAMBIO (TE-SMR)	TRANSMISSION, SHIFTER (TE-SMR)	BOITE DE VITESSE, COMMANDE DE VITESSE (TE-SMR)	WECHSELGETRIEBE, GANGSCHALTUNG (TE-SMR)	CAMBIO, MANDO CAMBIO (TE-SMR)	85
17	RAFFREDDAMENTO	COOLING SYSTEM	REFROIDISSEMENT	WASSERKÜHLUNG	ENFRIAMIENTO	91
18	FILTRO ARIA	AIR FILTER	FILTRE AIRE	LUFTFILTER	FILTRO DE AIRE	95
19	TELAIO, PEDANE	FRAME, FOOT RESTS	CADRE, REPOSE PIEDS	RAHMEN, FUSSBRETT	BASTIDOR, REPOSAPIES	97
20	SOSPENSIONE ANTERIORE (TE 250)	FRONT FORK ASSEMBLY (TE 250)	SUSPENSION AVANT (TE 250)	VORDERTELESKOPGABEL (TE 250)	SUSPENSION DELANTERA (TE 250)	101
20	SOSPENSIONE ANTERIORE (TE 450-510, TC, SM)	FRONT FORK ASSEMBLY (TE 450-510, TC, SM)	SUSPENSION AVANT (TE 450-510, TC, SM)	VORDERTELESKOPGABEL (TE 450-510, TC, SM)	SUSPENSION DELANTERA (TE 450-510, TC, SM)	109
21	FORCELLONE POSTERIORE	REAR SWING ARM	FOURCHE ARRIÈRE	HINTERGABEL	HORQUILLA TRASERA	117
22	AMMORTIZZATORE POSTERIORE (TE, SM)	REAR SHOCK ABSORBER (TE, SM)	AMMORTISSEUR ARRIÈRE (TE, SM)	HINTERSTOSSDAMPFER (TE, SM)	AMORTIGUADOR TRASERO (TE, SM)	121

Tavola Drawing Table Bild Tabla	Denominazione	Description	Designation	Bezeichnung	Denominacion	Pagina Page Page Seite Paja
22A	AMMORTIZZATORE POSTERIORE (TC)	REAR SHOCK ABSORBER (TC)	AMMORTISSEUR ARRIÈRE (TC)	HINTERSTOSSDAMPFER (TC)	AMORTIGUADOR TRASERO (TC)	125
23	LEVERAGGI SOSPENSIONE POSTERIORE	REAR SUSPENSION LINKAGE	LEVIER SUSPENSION ARRIERE	HEBELWERK HINTERHAUFHANGUNG	PALANCA SUSPENSION TRASERA	129
24	MANUBRIO E COMANDI	HANDLEBAR AND CONTROLS	GUIDON ET COMMANDES	LENKER UND STEUERORGANE	MANILLAR Y MANDOS	131
25	FRENO IDRAULICO POSTERIORE	REAR HYDRAULIC BRAKE	FREIN HYDRAULIQUE ARRIERE	HINTERBREMSE	FRENO HIDRAULICO TRASERO	135
26	PANNELLI LATERALI, PORTATARGA PARAFANGHI, SELLA	SIDE PANELS, FENDERS, SEAT, PLATE HOLDER	PANNEAU, GARDE-BOUES, SIEGE, PORTE-BALAI	STREIFEN, KOTFLUGEL, SATTEL SCHILDTRÄGER	PANELES, GUARDABARROS, SILLIN, PORTAMATRICULA	139
27	SERBATOIO CARBURANTE, CONVOGLIATORI	GAS TANK, PANELS	RESERVOIR CARBURANT, FLANCS	KRAFTSTOFFBEHALTER, FLANKE	DEPOSITO GASOLINA, LATERALES	145
28	SCARICO	EXHAUST SYSTEM	TUYAU D'ECHAPPEMENT	AUSPUFFROHR	TUBO DE ESCAPE	147
29	FRENO IDRAULICO ANT. (TE, TC)	FRONT HYDRAULIC BRAKE (TE, TC)	FREIN HYDRAULIQUE AV. (TE, TC)	VORTERBREMSE (TE, TC)	FRENO HIDRAULICO DELANTERO (TE, TC)	151
29A	FRENO IDRAULICO ANT. (SMR)	FRONT HYDRAULIC BRAKE (SMR)	FREIN HYDRAULIQUE AV. (SMR)	VORTERBREMSE (SMR)	FRENO HIDRAULICO DEL. (SMR)	155
30	RUOTA ANTERIORE (TE, TC)	FRONT WHEEL (TE, TC)	ROUE AVANT (TE, TC)	VORTERRAD (TE, TC)	RUEDA DELANTERA (TE, TC)	157
30A	RUOTA ANTERIORE (SMR)	FRONT WHEEL (SMR)	ROUE AVANT (SMR)	VORTERRAD (SMR)	RUEDA DELANTERA (SMR)	159
31	RUOTA POSTERIORE	REAR WHEEL	ROUE ARRIERE	HINTERRAD	RUEDA TRASERA	161
32	STRUMENTO DIGITALE, INDICATORI AVVISATORE ACUSTICO (TE-SMR)	DIGITAL INSTRUMENT, BLINKERS, HORN (TE-SMR)	INSTRUMENT DIGITAL, CLIGNOTANTS, SIGNALATEUR ACOUSTIQUE (TE-SMR)	DIGITAL TACHOMETER, BLINKERS, HUPE (TE-SMR)	INSTRUMENTO DIGITAL, INTERMITENTES AVISADOR ACUSTICO (TE-SMR)	165
33	GRUPPO CAVI, PARTI ELETTRICHE (TC, TE-USA)	MAIN WIRING HARNESS, ELECTRICAL PARTS (TC, TE-USA)	CABLES PRINCIPAL, PARTIES ELECTRIQUES (TC, TE-USA)	KABEL, ELEKTRISCHE KOMPONENTE (TC, TE-USA)	GRUPO PRINCIPAL CABLES, PARTES ELECTRICAS (TC, TE-USA)	169
33A	GRUPPO CAVI, PARTI ELETTRICHE, FANALI (TE-SMR)	MAIN WIRING HARNESS, LIGHTS, ELECTRICAL PARTS (TE-SMR)	CABLES PRINCIPAL, FEU PARTIES ELECTRIQUES (TE-SMR)	KABEL, LAMPEN, ELEKTRISCHE KOMPONENTE (TE-SMR)	GRUPO PRINCIPAL CABLES, FANALES, PARTES ELECTRICAS (TE-SMR)	173
34	DECALCOMANIE (TE) (codice colore E)	TRANSFER (TE) (color code E)	DECALCOMANIE (TE) (code couleur E)	ABZIEHBILD (TE) (Code Farbe E)	CALCOMANIA (TE) (còdigo colòr E)	177
35	DECALCOMANIE (TC) (codice colore G)	TRANSFER (TC) (color code G)	DECALCOMANIE (TC) (code couleur G)	ABZIEHBILD (TC) (Code Farbe G)	CALCOMANIA (TC) (còdigo colòr G)	179
36	DECALCOMANIE (SMR) (codice colore E)	TRANSFER (SMR) (color code E)	DECALCOMANIE (SMR) (code couleur E)	ABZIEHBILD (SMR) (Code Farbe E)	CALCOMANIA (SMR) (còdigo colòr E)	181
37	DECALCOMANIE (SMR) (codice colore G)	TRANSFER (SMR) (color code G)	DECALCOMANIE (SMR) (code couleur G)	ABZIEHBILD (SMR) (Code Farbe G)	CALCOMANIA (SMR) (còdigo colòr G)	183
38	CANISTER (TE-SMR)	CANISTER (TE-SMR)	CANISTER (TE-SMR)	CANISTER (TE-SMR)	CANISTER (TE-SMR)	185
-	INDICE NUMERICO PROGRESSIVO	NUMERICAL INDEX	INDEX NUMERIQUE	NUMMERNVERZEICHNIS	ÍNDICE NUMÉRICO PROGRESIVO	186

Tavola - Drawing - Table - Bild - Tabla **1**

Pagina - Page - Page - Seite - Paja **14**

Tavola - Drawing - Table - Bild - Tabla **2**

Pagina - Page - Page - Seite - Paja **16**

Tavola - Drawing - Table - Bild - Tabla **3**

Pagina - Page - Page - Seite - Paja **20**

Tavola - Drawing - Table - Bild - Tabla **4**

A Vedi tavola 10  
See drawing 10  
Voir table 10  
Sehen Bild 10  
Ver siehe 10

B Vedi tavola 24  
See drawing 24  
Voir Table 24  
Sehen Bild 24  
Ver siehe 24

Pagina - Page - Page - Seite - Paja **26**

Tavola - Drawing - Table - Bild - Tabla **5**

Pagina - Page - Page - Seite - Paja **34**

Tavola - Drawing - Table - Bild - Tabla **6**

Vedi Tavola 15  
See Drawing 15  
Voir Table 15  
Sehen Bild 15  
Ver Table 15

Pagina - Page - Page - Seite - Paja **36**



Tavola - Drawing - Table - Bild - Tabla

7

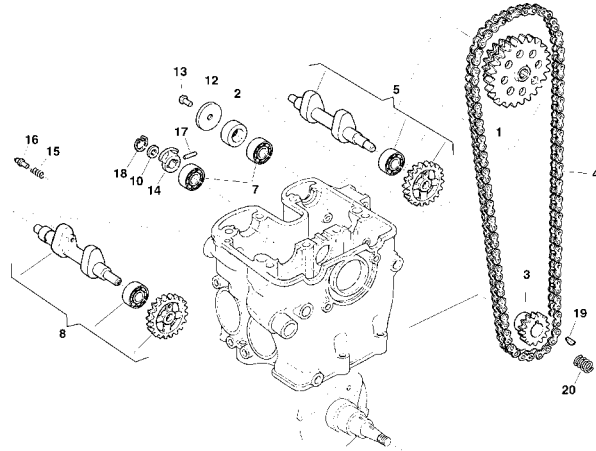

Pagina - Page - Page - Seite - Paja

40

Tavola - Drawing - Table - Bild - Tabla

8

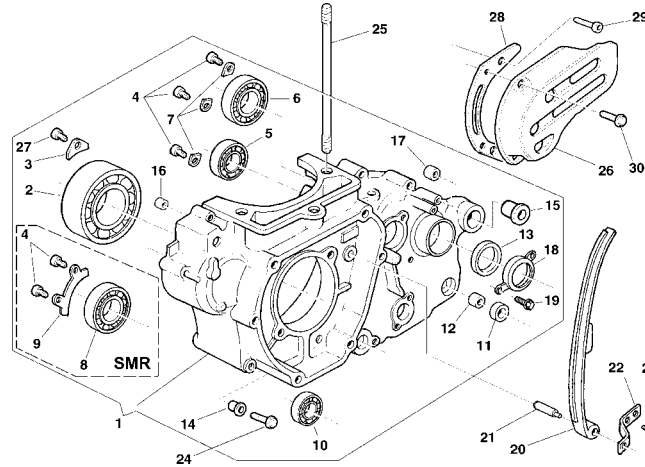

Pagina - Page - Page - Seite - Paja

44

Tavola - Drawing - Table - Bild - Tabla

9

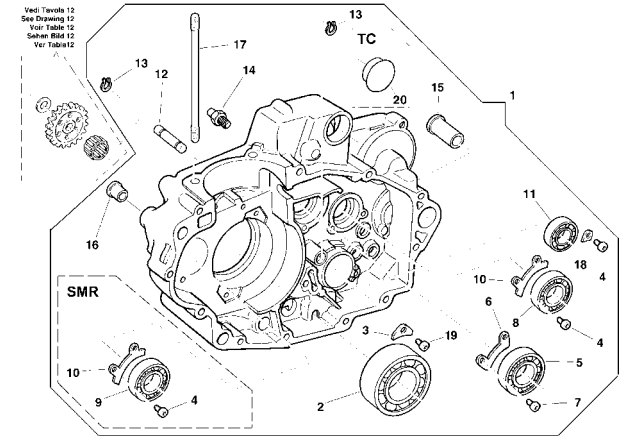

Pagina - Page - Page - Seite - Paja

48

Tavola - Drawing - Table - Bild - Tabla

10

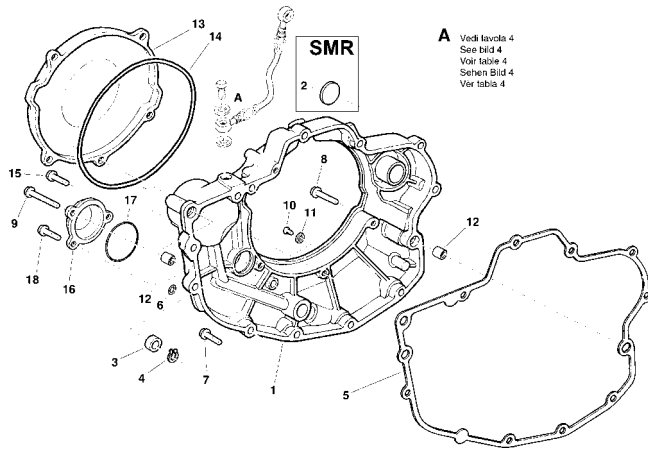

Pagina - Page - Page - Seite - Paja

52

Tavola - Drawing - Table - Bild - Tabla

11

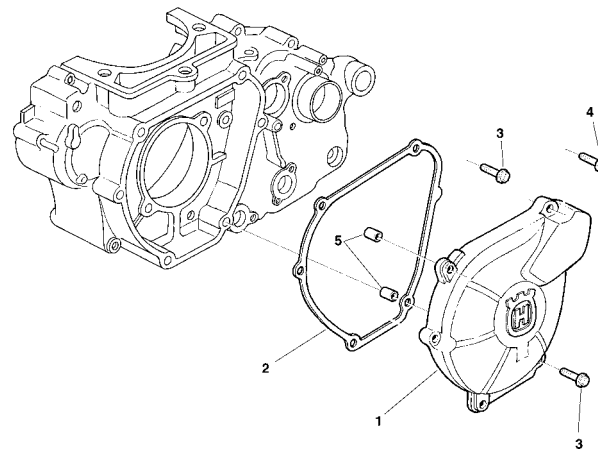

Pagina - Page - Page - Seite - Paja

54

Tavola - Drawing - Table - Bild - Tabla

12

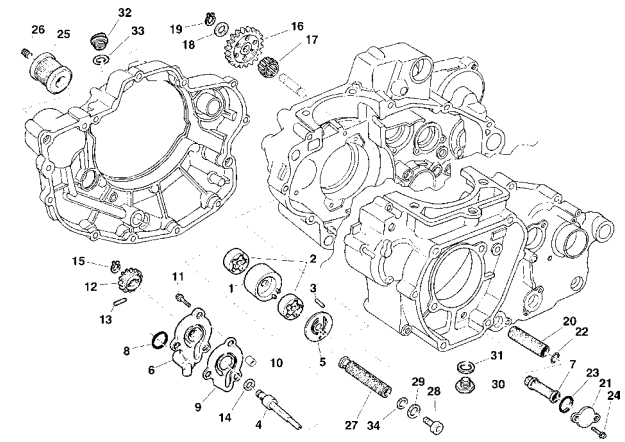

Pagina - Page - Page - Seite - Paja

56

Tavola - Drawing - Table - Bild - Tabla

13

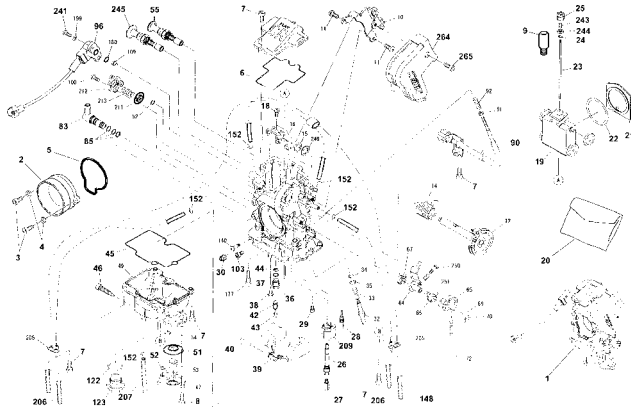

Pagina - Page - Page - Seite - Paja

60

Tavola - Drawing - Table - Bild - Tabla

13A

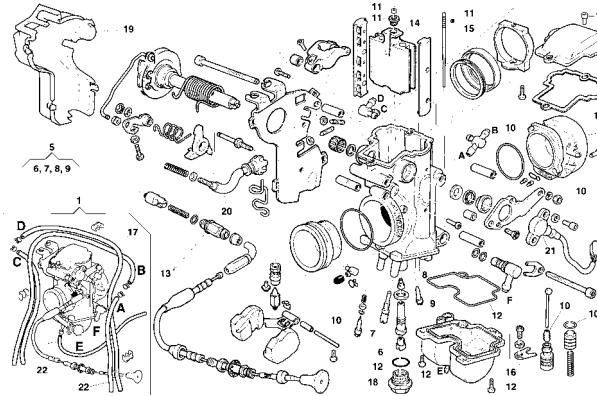

Pagina - Page - Page - Seite - Paja

66

Tavola - Drawing - Table - Bild - Tabla

14

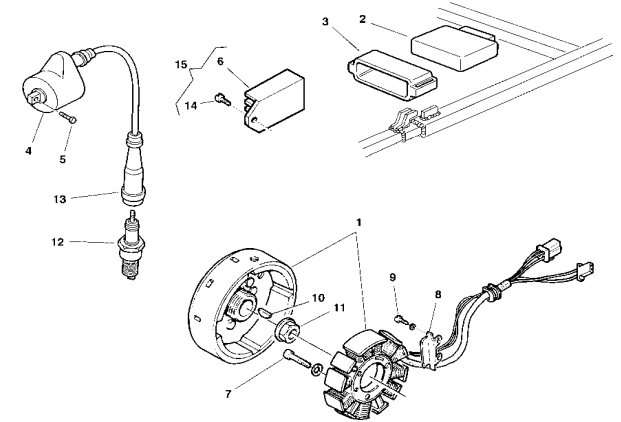

Pagina - Page - Page - Seite - Paja

68

Tavola - Drawing - Table - Bild - Tabla

15

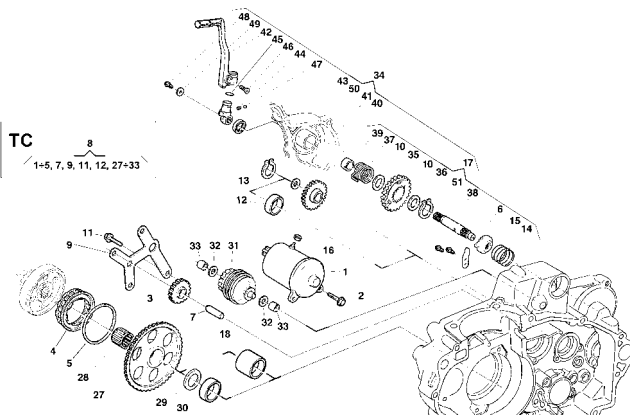

Pagina - Page - Page - Seite - Paja

72

Tavola - Drawing - Table - Bild - Tabla

16

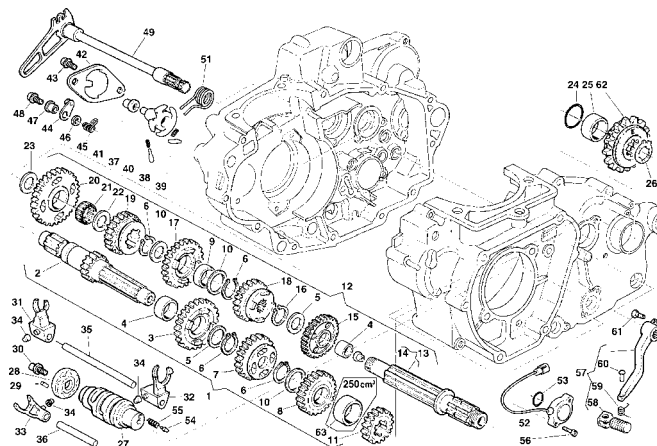

Pagina - Page - Page - Seite - Paja

76

Tavola - Drawing - Table - Bild - Tabla

16A

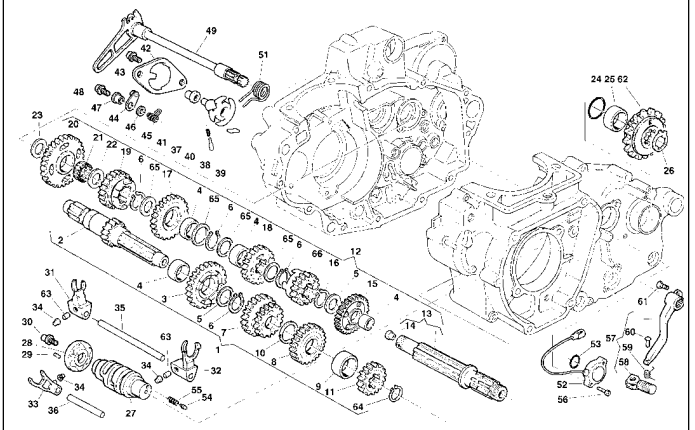

Pagina - Page - Page - Seite - Paja

84

Tavola - Drawing - Table - Bild - Tabla

17

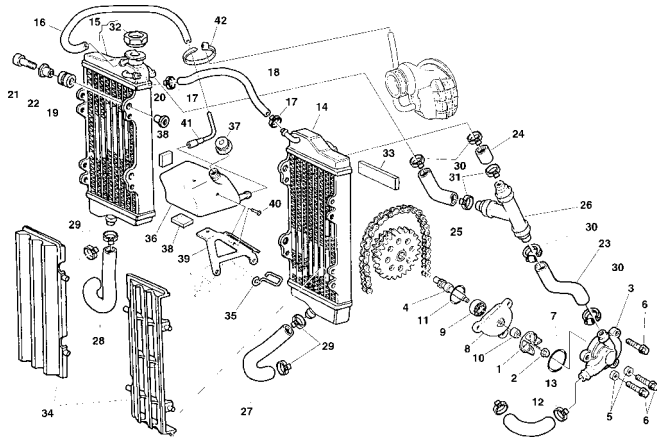

Pagina - Page - Page - Seite - Paja

90

Tavola - Drawing - Table - Bild - Tabla

18

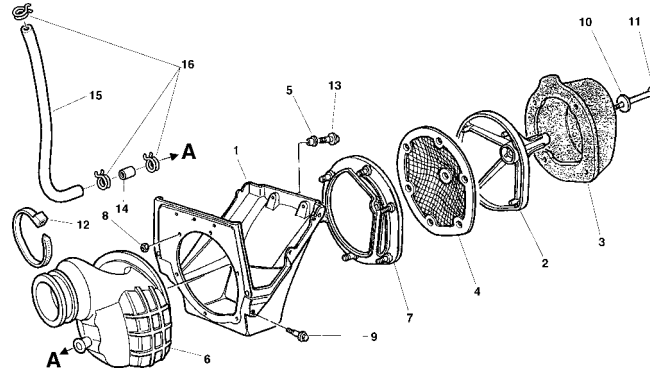

Pagina - Page - Page - Seite - Paja

94

Tavola - Drawing - Table - Bild - Tabla

19

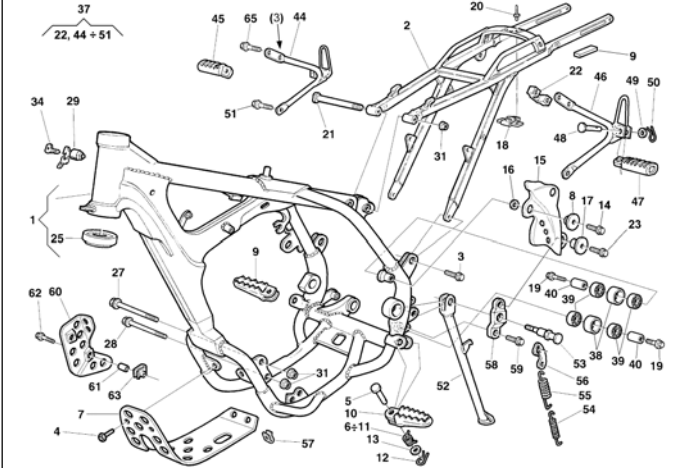

Pagina - Page - Page - Seite - Paja

96

Tavola - Drawing - Table - Bild - Tabla

20

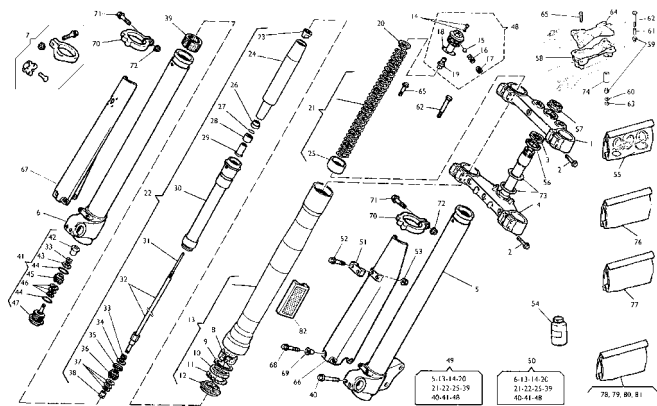

Pagina - Page - Page - Seite - Paja

100

Tavola - Drawing - Table - Bild - Tabla

20A

DA DEFINIRE  
TO BE DEFINE

Pagina - Page - Page - Seite - Paja

108

Tavola - Drawing - Table - Bild - Tabla

21

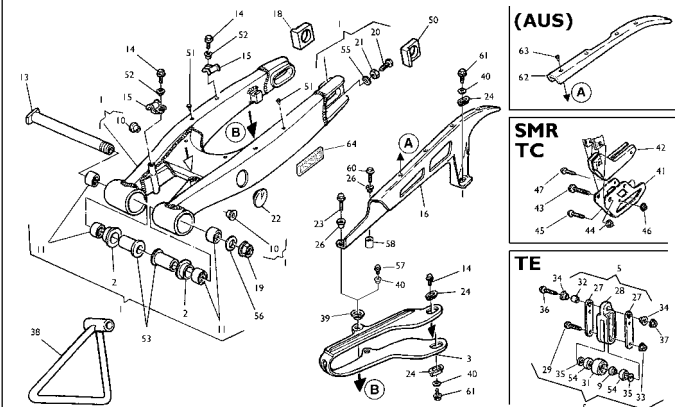

Pagina - Page - Page - Seite - Paja

116



Tavola - Drawing - Table - Bild - Tabla

22

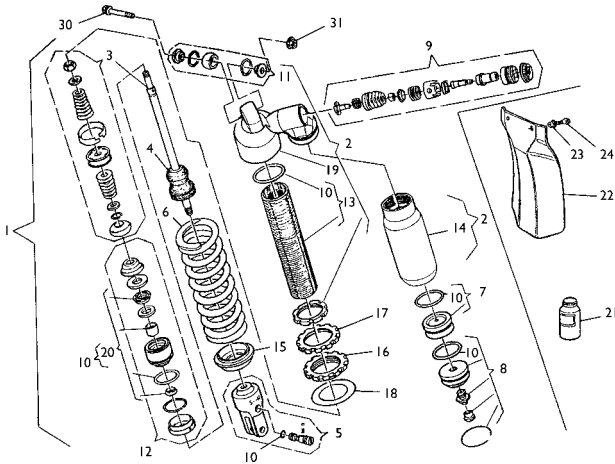

Pagina - Page - Page - Seite - Paja

120

Tavola - Drawing - Table - Bild - Tabla

22A

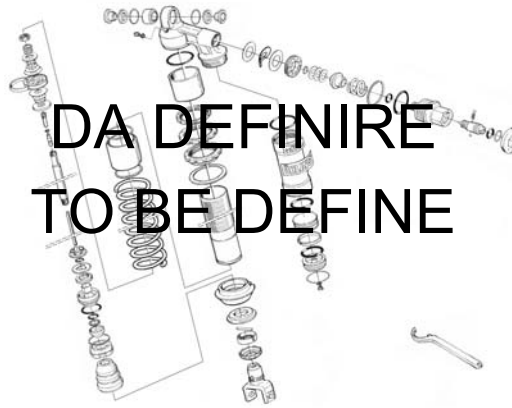

Pagina - Page - Page - Seite - Paja

124

Tavola - Drawing - Table - Bild - Tabla

23

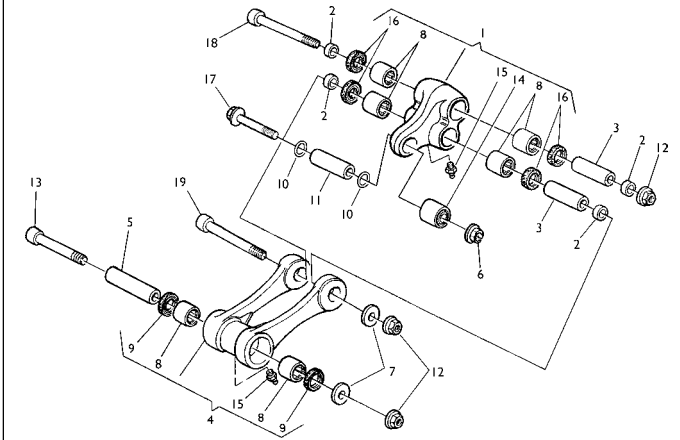

Pagina - Page - Page - Seite - Paja

128

Tavola - Drawing - Table - Bild - Tabla

24

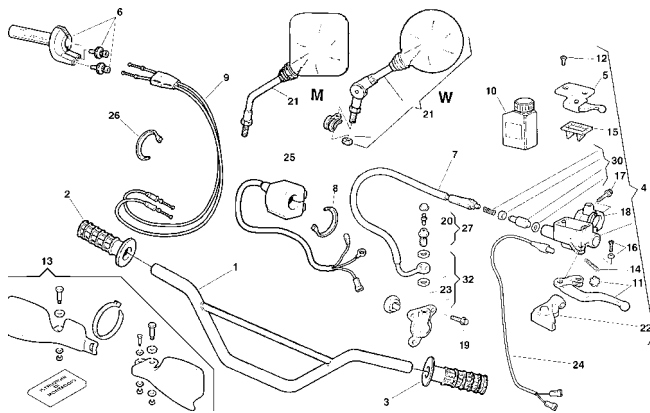

Pagina - Page - Page - Seite - Paja

130

Tavola - Drawing - Table - Bild - Tabla

25

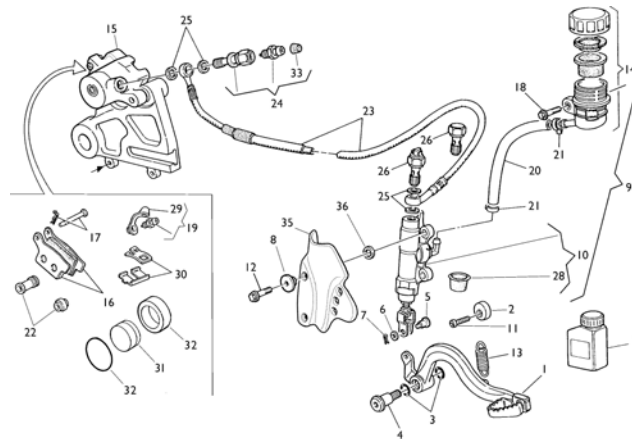

Pagina - Page - Page - Seite - Paja

134

Tavola - Drawing - Table - Bild - Tabla

26

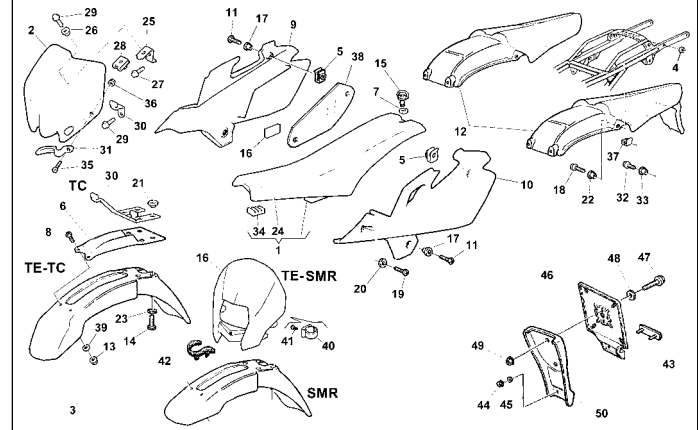

Pagina - Page - Page - Seite - Paja

138

Tavola - Drawing - Table - Bild - Tabla

27

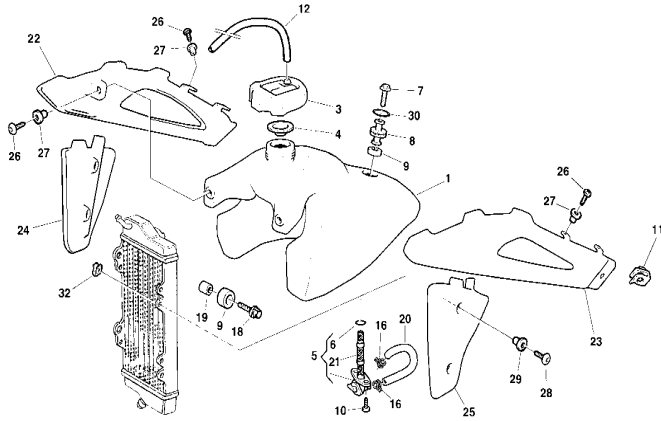

Pagina - Page - Page - Seite - Paja

144

Tavola - Drawing - Table - Bild - Tabla

28

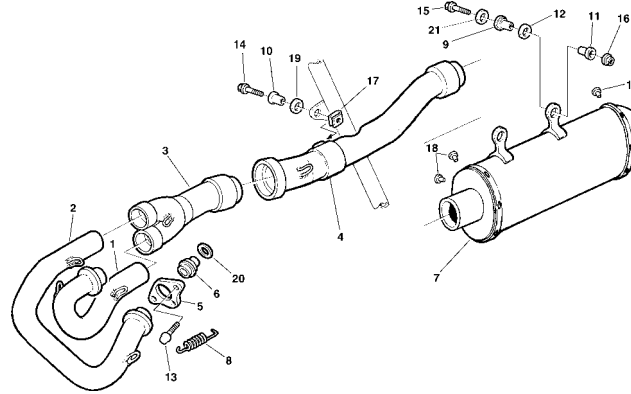

Pagina - Page - Page - Seite - Paja

146

Tavola - Drawing - Table - Bild - Tabla

29

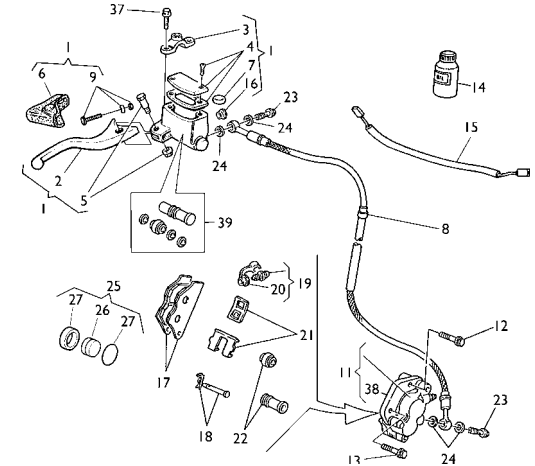

Pagina - Page - Page - Seite - Paja

150

Tavola - Drawing - Table - Bild - Tabla

29A

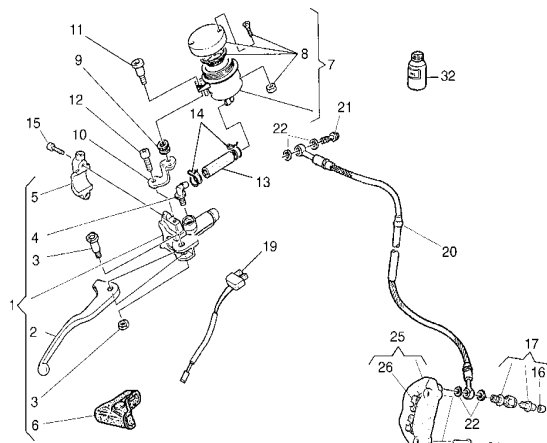

Pagina - Page - Page - Seite - Paja

154

Tavola - Drawing - Table - Bild - Tabla

30

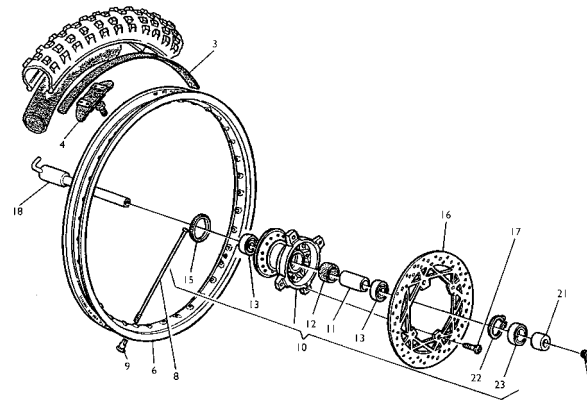

Pagina - Page - Page - Seite - Paja

156

Tavola - Drawing - Table - Bild - Tabla

30A

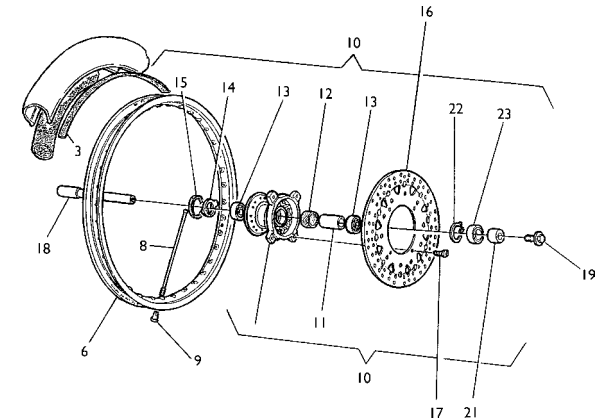

Pagina - Page - Page - Seite - Paja

158

Tavola - Drawing - Table - Bild - Tabla **31**

Pagina - Page - Page - Seite - Paja **160**

Tavola - Drawing - Table - Bild - Tabla **32**

Pagina - Page - Page - Seite - Paja **164**

Tavola - Drawing - Table - Bild - Tabla **33**

Pagina - Page - Page - Seite - Paja **168**

Tavola - Drawing - Table - Bild - Tabla **33A**

Pagina - Page - Page - Seite - Paja **172**

Tavola - Drawing - Table - Bild - Tabla **34**

Pagina - Page - Page - Seite - Paja **176**

Tavola - Drawing - Table - Bild - Tabla **35**

Pagina - Page - Page - Seite - Paja **178**

Tavola - Drawing - Table - Bild - Tabla

36



Pagina - Page - Page - Seite - Paja

180

Tavola - Drawing - Table - Bild - Tabla

37



Pagina - Page - Page - Seite - Paja

182

Tavola - Drawing - Table - Bild - Tabla

38

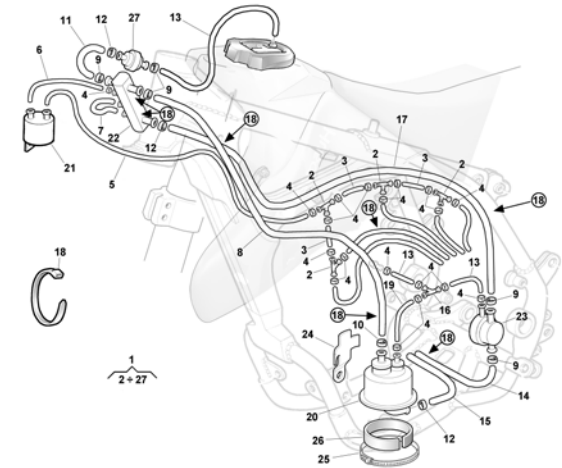

Pagina - Page - Page - Seite - Paja

184



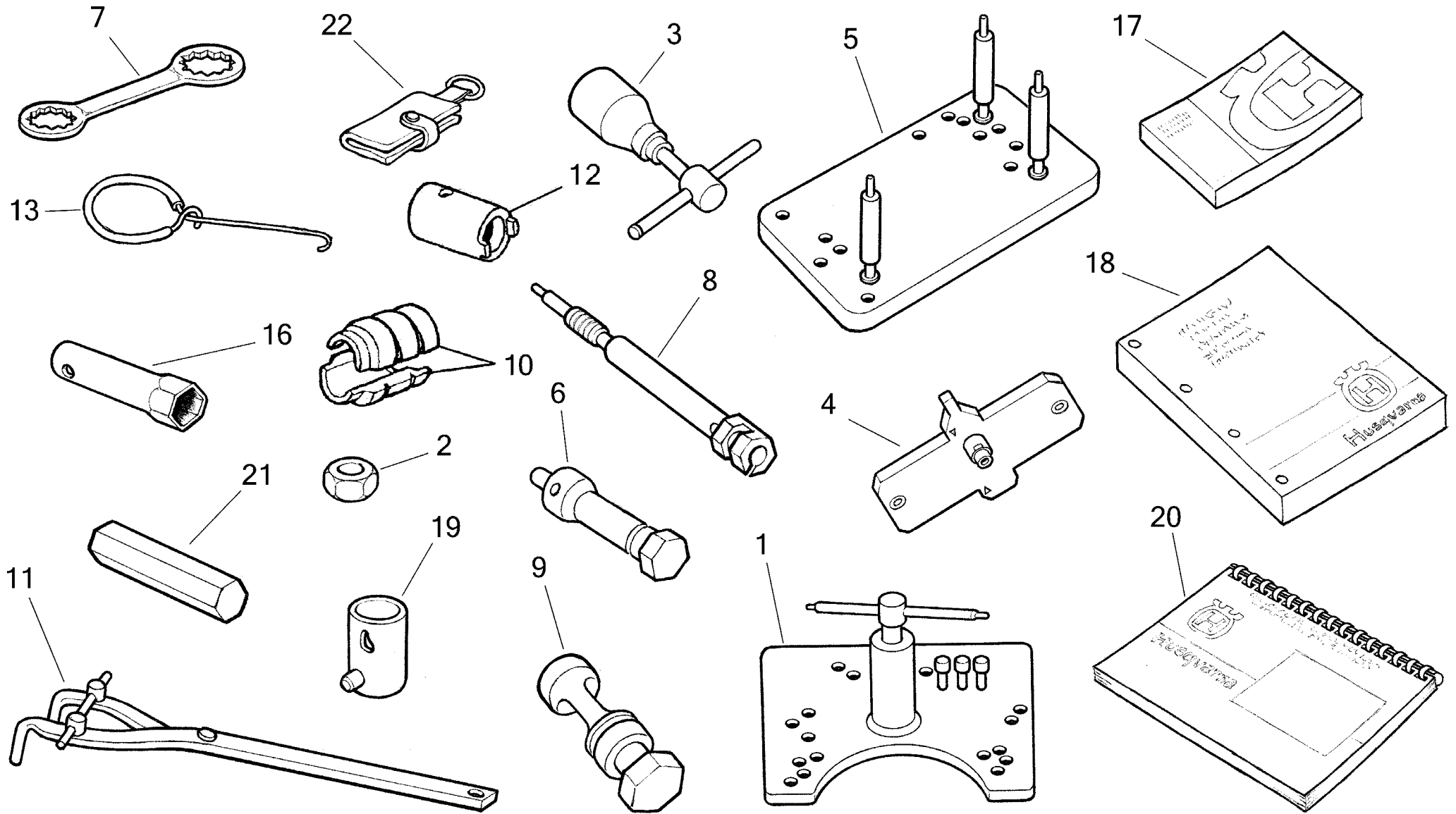

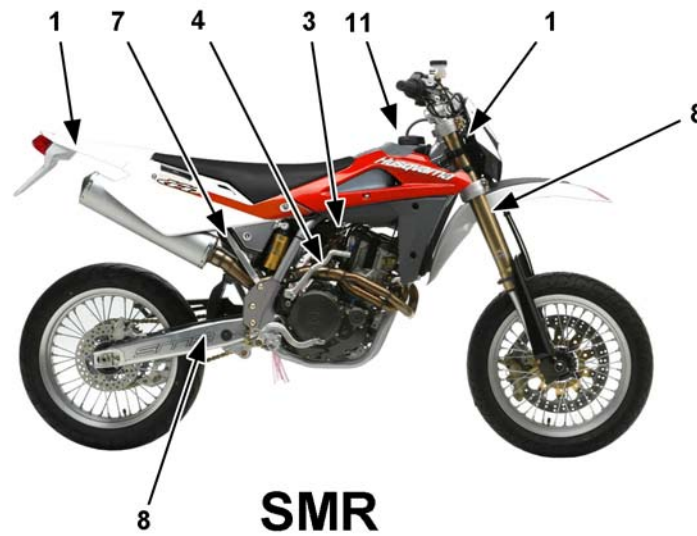
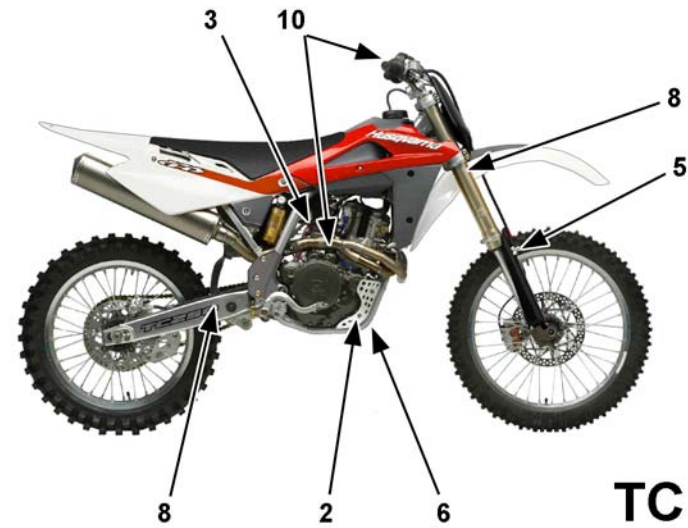
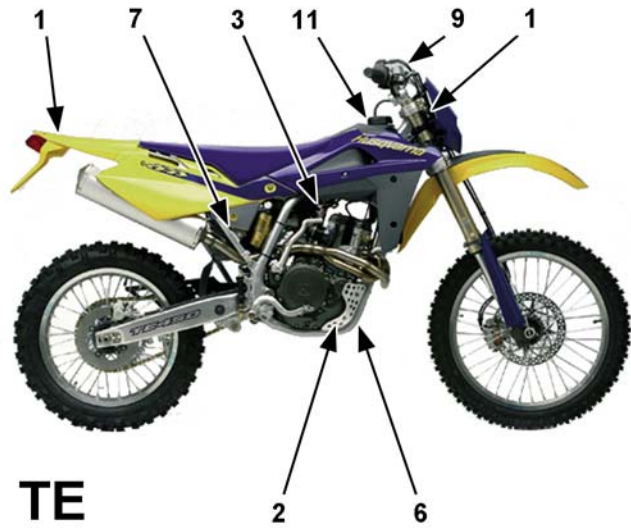

Note Notes Notas	Pos. No. N. Index Pos.	N. Cod. Code No. Nr. Code Code Nr N. Cod.	Q.tà Q.ty Q.te M.ge C.ad	DENOMINAZIONE	NAME	DESIGNATION	BESHREIBUNG	DENOMINACION	Validità Validity Validité Gültig Validez
	1	1517 94702	1	Estrattore basamento	Crankcase puller	Extracteur carter	Kurbelgehäuse-Auszieher	Extractor cárter	
	2	8000 A1580		Protezione alb. motore	Crankshaft guard	Protection vilebrequin	Schutz für Kurbewelle	Protección por cigueñal	
	3	8000 A1559	1	Estrattore volano	Flywheel extractor	Extracteur pour volant	Auszieher für Schwungrad	Extractor volante	
	4	8000 A1512		Attrezzo contr. accensione	Ignition checking tool	Outil contrôle allumage	Kontrollwerkzeug für Zündung	Herramienta control encendido	
	5	8A00 90662	1	Supporto per montaggio	Support for assy	Support pour montage	Halterung für Montage	Soporte por el montaje	
	6	8000 A5773		Attrezzo mont. semiconi Ø 5,0	Half cone assembling tool Ø 5,0	Outil montage demi-cône Ø 5,0	Werkzeug für montage der Half-Kebel Ø 5,0	Herramienta montaje semi-conos Ø 5,0	
	6	8A00 A5773		Attrezzo mont. semiconi Ø 5,5	Half cone assembling tool Ø 5,5	Outil montage demi-cône Ø 5,5	Werkzeug für montage der Half-Kebel Ø 5,5	Herramienta montaje semi-conos Ø 5,5	
<b>D</b>	7	8000 66802	1	Chiave poligonale	Poligonal wrench	Cléf polygonale	Sechskantschlüssel	Llave poligonal	
	8	8000 A1625		Attrezzo portacomparatore	Dial gauge holding tool	Outil support comparateur	Werkzeug Komparatorhalter	Herramienta porta comparador	
	9	8000 A1579		Attrezzo smont. semiconi	Half cone disassembling tool	Outil demontage demi-cône	Werkzeug für Ausbau der Half-Kebel	Herramienta desmontaje semi-conos	
	10	8000 91288	1	Introduttore MIM	Jaw	Machoire	Zusatzbache	Tenaza	
	11	8000 79015	1	Chiave di fermo mozzo frizione	Clutch hub retaining wrench	Cléf d'arret moyeau embrayage	Halterungsschlüssel der Kupplungsnahe	Llave bloquear cubo fricción	
	12	8000 91289	1	Attrezzo blocca cartuccia	Pumping retainer	Arrêt pompage embrayage	Klammer pumpen Kupplungsnahe	Bombedora	
	13	1519 84701	1	Gancio per molle	Spring hook	Crochet pour ressort	Federhaken	Gancho para resorte	
<b>D</b>	16	8000 A4349	1	Chiave candela	Spark plug wrench	Cléf bougie	Zündkerzeschlüssel	Llave bujia	
<b>D</b>	17	8000 A5910	1	Libretto uso e manuten.	Owner's manual	Emploi d'entretien	Betriebsanleitung	Manual uso y manten.	
<b>R</b>	18	8000 A5911	1	Manuale di officina	Workshop manual	Mauel d'atelier	Werkstatthandbuch	Manual de officina	
<b>D</b>	19	8000 96997	1	Chiave perno ruota anteriore	Front wheel axle wrench	Cléf pivot roue avant	Vorterrad bolzen schlüssel	Llave perno rueda delantera	
<b>R</b>	20	8000 A5912	1	Catalogo PARTI DI RICAMBIO	SPARE PARTS catalog	Catalogue PIECES DE RECHANGE	ERSATZTEILKATALOG	Catalogo PIEZAS DE REPUESTO	
<b>D</b>	21	8000 56920	1	Chiave esagonale per vite perno ruota anteriore	Front wheel axle screw Allen wrench	Clef à douille pour vis de pivot roue avant	Sechs Kantschlüssel für Vorderradbolzen schraube	Llave hexagonal por tornillo perno rueda delantera	
<b>DW</b>	22	8000 97615	1	Porta chiavi	Key-ring	Porte-clefs	Schlüsselring	Llavero	



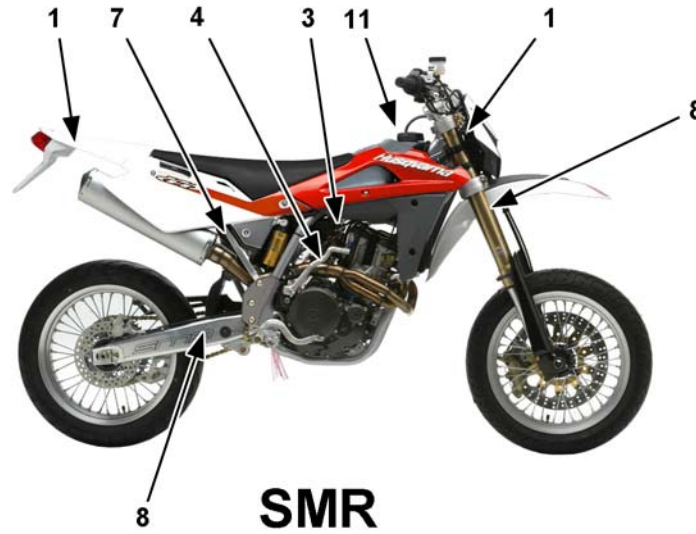
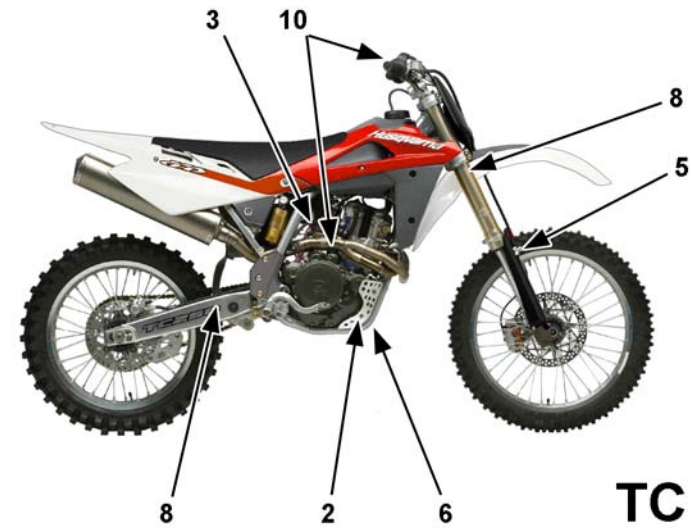
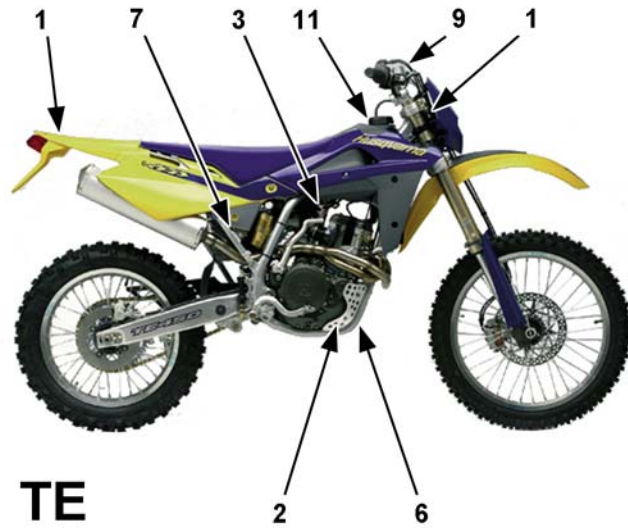

Note Notes Notas	Pos. No. N. Index Pos.	N. Cod. Code No. Nr. Code Code Nr N. Cod.	Q.tà Q.ty Q.te M.ge C.ad	DENOMINAZIONE	NAME	DESIGNATION	BESHREIBUNG	DENOMINACION	Validità Validity Validité Gültig Validez
WM	1	8B00 A0226	1	Kit indicatori di direzione (Posizioni 6, 11, 25, 26 TAVOLA 34)	Blinkers Kit (No. 6, 11, 25, 26 DRAW. 34)	Kit clignotants (N. 6, 11, 25, 26 TABLE 34)	Blinkers Kit (Index 6, 11, 25, 26 BILD 34)	Kit intermitentes (Pos. 6, 11, 25, 26 TABLA 34)	
WC	2	8000 A1427	1	Protezione carter destro (Pos. 60 TAVOLA 19)	R.H. crankcase guard (No. 60 DRAWING 19)	Protection couvercle carter D. (N. 60 TABLE 19)	R. Gehäusedeckel Schutz (Index 60 BILD 19)	Protección tapabancada der. (Pos. 60 TABLA 19)	
	3	8000 A4295	1	Kit carburat. KEIHIN (TC 250) (Pos. 20 TAVOLA 13)	Carburetor kit (TC 250) (No. 20 DRAWING 13)	Kit carburateur (TC 250) (N. 20 TABLE 13)	Vergaser Kit (TC 250) (Index 20 BILD 13)	Kit carburador (TC 250) (Pos. 20 TABLA 13)	
	3	8000 A6115	1	Kit carburat. KEIHIN (TE 250) (Pos. 20 TAVOLA 13)	Carburetor kit (TE 250) (No. 20 DRAWING 13)	Kit carburateur (TE 250) (N. 20 TABLE 13)	Vergaser Kit (TE 250) (Index 20 BILD 13)	Kit carburador (TE 250) (Pos. 20 TABLA 13)	
	3	8000 A4296	1	Kit carburat. KEIHIN (TC 450-510) (Pos. 20 TAVOLA 13)	Carburetor kit (TC 450-510) (No. 20 DRAWING 13)	Kit carburateur (TC 450-510) (N. 20 TABLE 13)	Vergaser Kit (TC 450-510) (Index 20 BILD 13)	Kit carburador (TC 450-510) (Pos. 20 TABLA 13)	
	3	8000 A5918	1	Kit carburat. KEIHIN (TE-SMR 450-510) (Pos. 20 TAVOLA 13)	Carburetor kit (TE-SMR 450-510) (No. 20 DRAWING 13)	Kit carburateur (TE-SMR 450-510) (N. 20 TABLE 13)	Vergaser Kit (TE-SMR 450-510) (Index 20 BILD 13)	Kit carburador (TE-SMR 450-510) (Pos. 20 TABLA 13)	
	3	8000 A3091	1	Kit carburat. MIKUNI TMR 38 (SMR 400) (Pos. 5 TAVOLA 13A)	Carburetor kit (SMR 400) (No. 5 DRAWING 13A)	Kit carburateur (SMR 400) (N. 5 TABLE 13A)	Vergaser Kit (SMR 400) (Index 5 BILD 13A)	Kit carburador (SMR 400) (Pos. 5 TABLA 13A)	
M	4	8000 A4547	1	Kit avviamento a pedale (Pos. 34 TAVOLA 15)	Kick starter kit (No. 34 DRAWING 15)	Kit démarrage à pédale (N. 34 TABLE 15)	Kit Kickstarter (Index 34 BILD 15)	Kit arranque a pedal (Pos. 34 TABLA 15)	
C	5	8000 A3191	1	Kit gancio partenza (TC) (Pos. 7 TAVOLA 20)	Kit starting hook (TC) (No. 7 DRAWING 20)	Kit crochet pour départ (TC) (N. 7 TABLE 20)	Abfahrthacken (TC) (Index 7 BILD 20)	Gancho por salida (TC) (Pos. 7 TABLA 20)	
WC	6	8000 A0865	1	Paramotore (Pos. 7 TAVOLA 19)	Engine guard (No. 7 DRAWING 19)	Garde moteur (N. 7 TABLE 19)	Motorschutz (Index 7 BILD 19)	Para motor (Pos. 7 TABLA 19)	
WM	7	8000 A0677	1	Kit compl. poggiapiedi (Pos. 37 TAVOLA 19)	Compl. footrest Kit (No. 37 DRAWING 19)	Appui-pied complet (N. 37 TABLE 19)	kompl. Fussraster-Kit (Index 37 BILD 19)	Kit compl. apoyapiés (Pos. 37 TABLA 19)	
	8	8000 A4605	1	Kit CANADA (Pos. 82 TAVOLA 20) (Pos. 64 TAVOLA 21)	CANADA kit (No. 82 DRAWING 20) (No. 64 DRAWING 21)	Set CANADA (N. 82 TABLE 20) (N. 64 TABLE 21)	CANADA Kit (Index 82 BILD 20) (Index 64 BILD 21)	Grupo CANADA (Pos. 82 TABLA 20) (Pos. 64 TABLA 21)	
W	9	8000 A6211	1	Kit paramani (Pos. 13 TAVOLA 24)	Hand guard kit (No. 13 DRAWING 24)	Kit protection des mains (N. 13 TABLE 24)	Händeschutz kit (Index 13 BILD 24)	Kit protección manos (Pos. 13 TABLA 24)	



Note Notes Notas	Pos. No. N. Index Pos.	N. Cod. Code No. Nr. Code Code Nr N. Cod.	Q.tà Q.ty Q.te M.ge C.ad	DENOMINAZIONE	NAME	DESIGNATION	BESHREIBUNG	DENOMINACION	Validità Validity Validité Gültig Validez
	10	8000 A6487	1	Kit avviamento elettrico (TC 250) (Pos. 6, 14 TAVOLA 14, pos. 8 TAVOLA 15, pos. 2 TaVOLA 33)	Electric starting kit (TC 250) (No. 6, 14 DRAWING 14, no. 8 DRAWING 15, no. 2 DRAWING 33)	Kit démarrage électronique (TC 250) (N. 6, 14 TABLE 14, n. 8 TABLE 15, n. 2 TABLE 33)	Elektronisch Anlasser Kit (TC 250) (Index 6, 14 BILD 14, Index 8 BILD 15, Index 2 BILD 33)	Kit arranque electrónico (TC 250) (Pos. 6, 14 TABLA 14, pos. 8 TABLA 15, pos. 2 TABLA 33)	
	10	8000 A6488	1	Kit avviamento elettrico (TC 450-510) (Pos. 6, 14 TAVOLA 14, pos. 8 TAVOLA 15, pos. 2 TaVOLA 33)	Electric starting kit (TC 450-510) (No. 6, 14 DRAWING 14, no. 8 DRAWING 15, no. 2 DRAWING 33)	Kit démarrage électronique (TC 450-510) (N. 6, 14 TABLE 14, n. 8 TABLE 15, n. 2 TABLE 33)	Elektronisch Anlasser Kit (TC 450-510) (Index 6, 14 BILD 14, Index 8 BILD 15, Index 2 BILD 33)	Kit arranque electrónico (TC 450-510) (Pos. 6, 14 TABLA 14, pos. 8 TABLA 15, pos. 2 TABLA 33)	
W	11	8000 A5926	1	kit canister (U.S.A.-CDN) (Pos. 1 TAVOLA 38)	Canister kit (U.S.A.-CDN) (No. 1 DRAWING 38)	Kit canister (U.S.A.-CDN) (N. 1 TABLE 38)	Canister Kit (U.S.A.-CDN) (Index 1 BILD 38)	Canister kit (U.S.A.-CDN) (Pos. 1TABLA 38)	

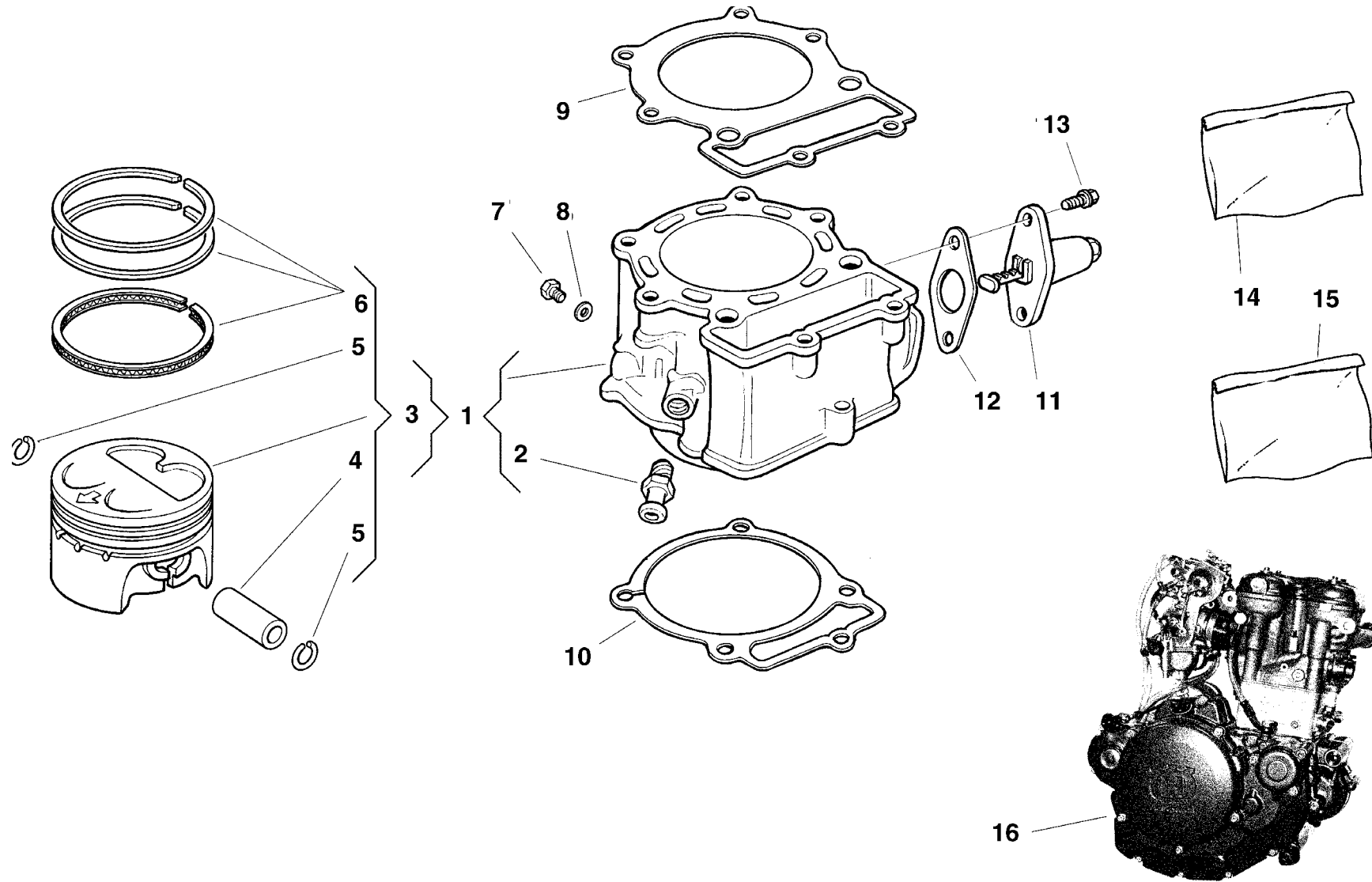



Note Notes Marke Notas	Pos. No. N. Index Pos.	N. Cod. Code No. Nr. Code Code Nr N. Cod.	Q.tà Q.ty Q.te M.ge C.ad	DENOMINAZIONE	NAME	DESIGNATION	BESHREIBUNG	DENOMINACION	Validità Validity Validité Gültig Validez
	1	8000 A5456	1	Cilindro completo (250)	Cylinder assy (250)	Cylindre compl. (250)	Zylinder kpl. (250)	Cilindro compl. (250)	
	1	8000 99869	1	Cilindro completo (400)	Cylinder assy (400)	Cylindre compl. (400)	Zylinder kpl. (400)	Cilindro compl. (400)	
	1	8000 A6050	1	Cilindro completo (TE-SMR 450)	Cylinder assy (TE-SMR 450)	Cylindre compl. (TE-SMR 450)	Zylinder kpl. (TE-SMR 450)	Cilindro compl. (TE-SMR 450)	
<b>A</b>	1	8000 A5466	1	Cilindro completo (TE-SMR 450)	Cylinder assy (TE-SMR 450)	Cylindre compl. (TE-SMR 450)	Zylinder kpl. (TE-SMR 450)	Cilindro compl. (TE-SMR 450)	
	1	8000 A5470	1	Cilindro completo (TC 450)	Cylinder assy (TC 450)	Cylindre compl. (TC 450)	Zylinder kpl. (TC 450)	Cilindro compl. (TC 450)	
	1	8000 A5479	1	Cilindro completo (TE-SMR 510)	Cylinder assy (TE-SMR 510)	Cylindre compl. (TE-SMR 510)	Zylinder kpl. (TE-SMR 510)	Cilindro compl. (TE-SMR 510)	
	1	8000 A5483	1	Cilindro completo (TC 510)	Cylinder assy (TC 510)	Cylindre compl. (TC 510)	Zylinder kpl. (TC 510)	Cilindro compl. (TC 510)	
	2	8000 63885	2	Raccordo	Union	Raccord	Anschluss	Empalme	
	3	8000 A6110	1	Pistone completo (Ø 76 mm) (250)	Piston assy. (Ø 76 mm) (250)	Piston complet (Ø 76 mm) (250)	Kolben, kpl. (Ø 76 mm) (250)	Pistón completo (Ø 76 mm) (250)	
	3	8000 99870	1	Pistone completo (Ø 91,5 mm) (400)	Piston assy. (Ø 91,5 mm) (400)	Piston complet (Ø 91,5 mm) (400)	Kolben, kpl. (Ø 91,5 mm) (400)	Pistón completo (Ø 91,5 mm) (400)	
<b>@</b>	3	8000 A6052	1	Pistone completo (Ø 97 mm) (TE-SMR 450)	Piston assy. (Ø 97 mm) (TE-SMR 450)	Piston complet (Ø 97 mm) (TE-SMR 450)	Kolben, kpl. (Ø 97 mm) (TE-SMR 450)	Pistón completo (Ø 97 mm) (TE-SMR 450)	
<b>A&amp;</b>	3	8000 A5467	1	Pistone completo (Ø 97 mm) (TE-SMR 450)	Piston assy. (Ø 97 mm) (TE-SMR 450)	Piston complet (Ø 97 mm) (TE-SMR 450)	Kolben, kpl. (Ø 97 mm) (TE-SMR 450)	Pistón completo (Ø 97 mm) (TE-SMR 450)	
	3	8000 A5471	1	Pistone completo (Ø 97 mm) (TC 450)	Piston assy. (Ø 97 mm) (TC 450)	Piston complet (Ø 97 mm) (TC 450)	Kolben, kpl. (Ø 97 mm) (TC 450)	Pistón completo (Ø 97 mm) (TC 450)	
	3	8000 A5480	1	Pistone completo (Ø 97 mm) (TE-SMR 510)	Piston assy. (Ø 97 mm) (TE-SMR 510)	Piston complet (Ø 97 mm) (TE-SMR 510)	Kolben, kpl. (Ø 97 mm) (TE-SMR 510)	Pistón completo (Ø 97 mm) (TE-SMR 510)	
	3	8000 A5484	1	Pistone completo (Ø 97 mm) (TC 510)	Piston assy. (Ø 97 mm) (TC 510)	Piston complet (Ø 97 mm) (TC 510)	Kolben, kpl. (Ø 97 mm) (TC 510)	Pistón completo (Ø 97 mm) (TC 510)	
	4	8000 A5459	1	Spinotto (250)	Gudgeon (250)	Axe (250)	Bolzen (250)	Perno (250)	
	4	8000 99871	1	Spinotto (400)	Gudgeon (400)	Axe (400)	Bolzen (400)	Perno (400)	
<b>&amp;</b>	4	8000 A0008	1	Spinotto (TE-SMR 450-510)	Gudgeon (TE-SMR 450-510)	Axe (TE-SMR 450-510)	Bolzen (TE-SMR 450-510)	Perno (TE-SMR 450-510)	
<b>@</b>	4	8000 A0854	1	Spinotto (TE-SMR 450)	Gudgeon (TE-SMR 450)	Axe (TE-SMR 450)	Bolzen (TE-SMR 450)	Perno (TE-SMR 450)	
	4	8000 A5474	1	Spinotto (TC 450-510)	Gudgeon (TC 450-510)	Axe (TC 450-510)	Bolzen (TC 450-510)	Perno (TC 450-510)	
	5	8000 A5460	2	Anello di fermo (250)	Stop ring (250)	Bague d'arrêt (250)	Haltering (250)	Anillo de retención (250)	
	5	1615 35501	2	Anello di fermo (400)	Stop ring (400)	Bague d'arrêt (400)	Haltering (400)	Anillo de retención (400)	

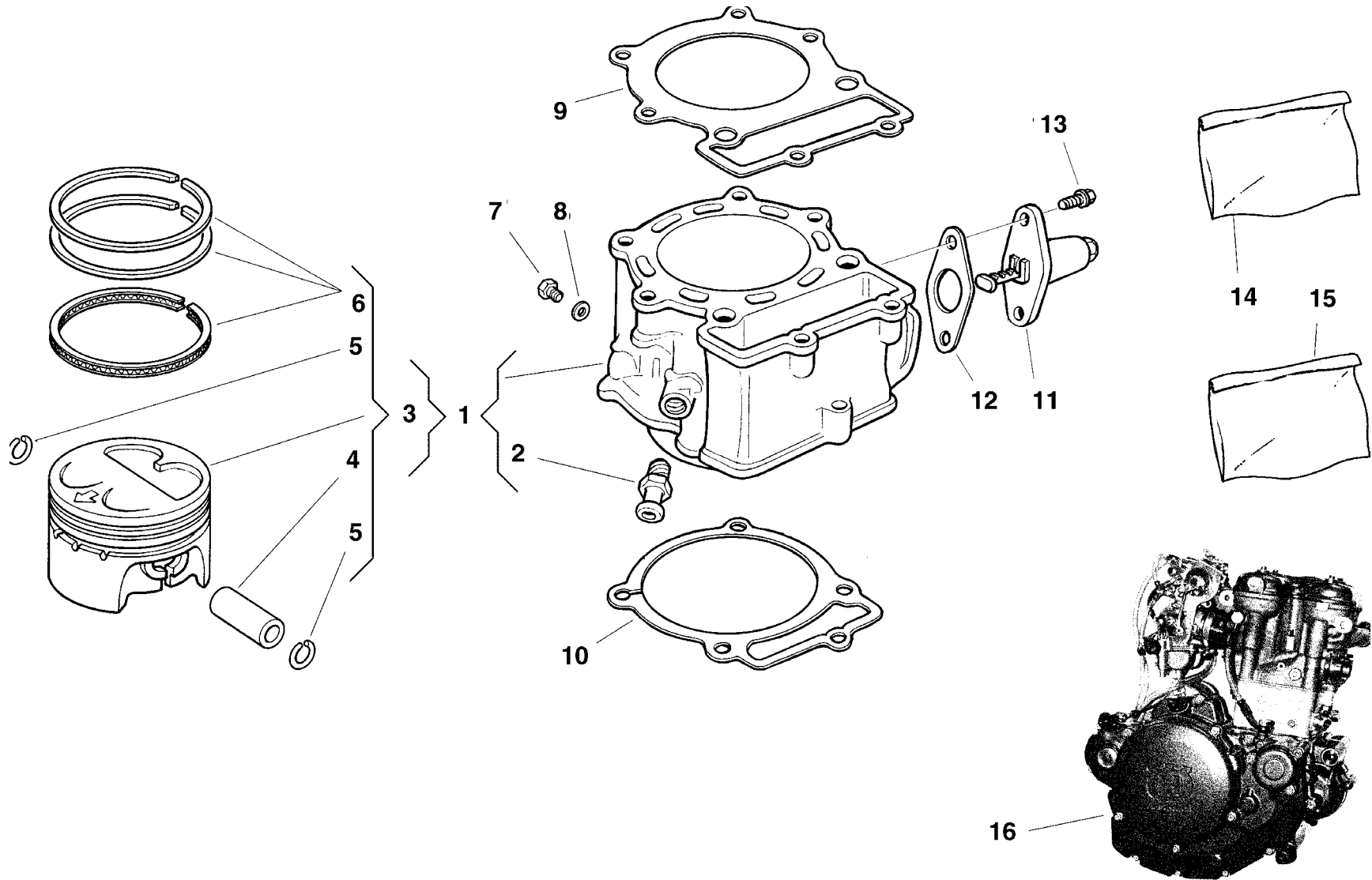

Note Notes Notas	Pos. No. N. Index Pos.	N. Cod. Code No. Nr. Code Code Nr N. Cod.	Q.tà Q.ty Q.te M.ge C.ad	DENOMINAZIONE	NAME	DESIGNATION	BESHREIBUNG	DENOMINACION	Validità Validity Validité Gültig Validez
@	5	8000 A3378	2	Anello di fermo (TE-SMR 450)	Stop ring (TE-SMR 450)	Bague d'arrêt (TE-SMR 450)	Haltering (TE-SMR 450)	Anillo de retención (TE-SMR 450)	
&	5	8000 A5396	2	Anello di fermo (TE-SMR 450-510)	Stop ring (TE-SMR 450-510)	Bague d'arrêt (TE-SMR 450-510)	Haltering (TE-SMR 450-510)	Anillo de retención (TE-SMR 450-510)	
	5	8000 A5475	2	Anello di fermo (TC 450-510)	Stop ring (TC 450-510)	Bague d'arrêt (TC 450-510)	Haltering (TC 450-510)	Anillo de retención (TC 450-510)	
	6	8000 A5923	1	Kit segmenti (250)	Circlip kit (250)	Kit segment (250)	Kolbenring kit (250)	Kit segmento (250)	
	6	8000 98116	1	Kit segmenti (400)	Circlip kit (400)	Kit segment (400)	Kolbenring kit (400)	Kit segmento (400)	
@	6	8000 A0855	1	Kit segmenti (TE-SMR 450)	Circlip kit (TE-SMR 450)	Kit segment (TE-SMR 450)	Kolbenring kit (TE-SMR 450)	Kit segmento (TE-SMR 450)	
&	6	8000 A0009	1	Kit segmenti (TE-SMR 450-510)	Circlip kit (TE-SMR 450-510)	Kit segment (TE-SMR 450-510)	Kolbenring kit (TE-SMR 450-510)	Kit segmento (TE-SMR 450-510)	
	6	8000 A5476	1	Kit segmenti (TC 450-510)	Circlip kit (TC 450-510)	Kit segment (TC 450-510)	Kolbenring kit (TC 450-510)	Kit segmentos (TC 450-510)	
	7	8S00 67545	1	Vite scarico acqua	Coolant draining screw	Vis	Schraube	Tornillo	
	8	8A00 15960	1	Rosetta	Washer	Rondelle	Scheibe	Arandela	
R	9	8A00 A5462	1	Guarnizione (0,7 mm) (250)	Gasket (0,7 mm) (250)	Garnitue (0,7 mm) (250)	Dichtung (0,7 mm) (250)	Junta (0,7 mm) (250)	
	9	8000 A5462	1	Guarnizione (0,8 mm) (250)	Gasket (0,8 mm) (250)	Garnitue (0,8 mm) (250)	Dichtung (0,8 mm) (250)	Junta (0,8 mm) (250)	
R	9	8B00 A5462	1	Guarnizione (0,9 mm) (250)	Gasket (0,9 mm) (250)	Garnitue (0,9 mm) (250)	Dichtung (0,9 mm) (250)	Junta (0,9 mm) (250)	
	9	8D00 99840	1	Guarnizione (1,0 mm) (400)	Gasket (1,0 mm) (400)	Garnitue (1,0 mm) (400)	Dichtung (1,0 mm) (400)	Junta (1,0 mm) (400)	
S	9	8A00 99840	1	Guarnizione (1,1 mm) (400)	Gasket (1,1 mm) (400)	Garnitue (1,1 mm) (400)	Dichtung (1,1 mm) (400)	Junta (1,1 mm) (400)	
	9	8G00 99840	1	Guarnizione (1,2 mm) (400)	Gasket (1,2 mm) (400)	Garnitue (1,2 mm) (400)	Dichtung (1,2 mm) (400)	Junta (1,2 mm) (400)	
	9	8E00 A4195	1	Guarnizione (1,0 mm)(450-510)	Gasket (1,0 mm) (450-510)	Garnitue (1,0 mm) (450-510)	Dichtung (1,0 mm) (450-510)	Junta (1,0 mm) (450-510)	
	9	8B00 A4195	1	Guarnizione (1,1 mm)(450-510)	Gasket (1,1 mm) (450-510)	Garnitue (1,1 mm) (450-510)	Dichtung (1,1 mm) (450-510)	Junta (1,1 mm) (450-510)	
	9	8H00 A4195	1	Guarnizione (1,2 mm)(450-510)	Gasket (1,2 mm) (450-510)	Garnitue (1,2 mm) (450-510)	Dichtung (1,2 mm) (450-510)	Junta (1,2 mm) (450-510)	
	10	8000 99841	1	Guarnizione	Gasket	Garnitue	Dichtung	Junta	
	11	8000 67744	1	Tenditore completo	Complete tensioner	Tendeur complet	Zylinderspanner	Tensor completo	
	12	1615 35801	1	Guarnizione	Gasket	Garnitue	Dichtung	Junta	
	13	8000 62727	2	Vite	Screw	Vis	Schraube	Tornillo	
R	14	8000 A5755	1	Gruppo guarn. motore (250)	Gasket set (250)	Groupe garnitures (250)	Dichtungssatz (250)	Grupo juntas (250)	
R	14	8000 A5981	1	Gruppo guarn. motore (400)	Gasket set (400)	Groupe garnitures (400)	Dichtungssatz (400)	Grupo juntas (400)	
R	14	8000 A5982	1	Gr. guarn. motore (450-510)	Gasket set (450-510)	Groupe garnitures (450-510)	Dichtungssatz (450-510)	Grupo juntas (450-510)	
R	15	8000 A5735	1	Gruppo anelli di tenuta motore (250)	Engine seal ring set (250)	Groupe bague moteur (250)	Dichtungringgruppe Motor (250)	Grupo anillos (250)	

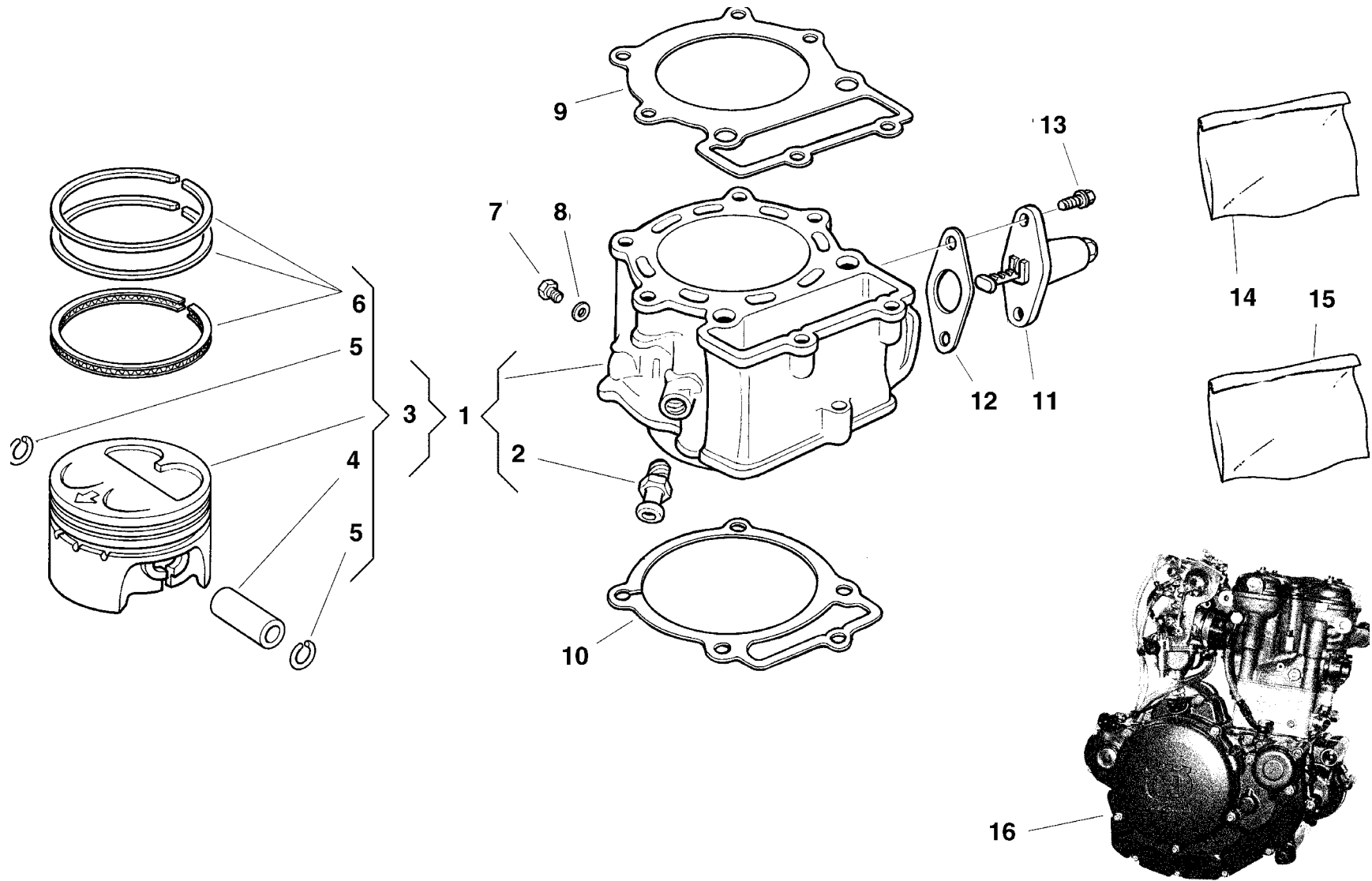

Note Notes Notas	Pos. No. Index Pos.	N. Cod. Code No. Nr. Code Code Nr N. Cod.	Q.tà Q.ty Q.te M.ge C.ad	DENOMINAZIONE	NAME	DESIGNATION	BESHREIBUNG	DENOMINACION	Validità Validity Validité Gültig Validez
<b>R</b>	15	8000 A5736	1	Gruppo anelli di tenuta motore (400-450-510)	Engine seal ring set (400-450-510)	Groupe bague moteur (400-450-510)	Dichtungringgruppe Motor (400-450-510)	Grupo anillos (400-450-510)	
	16	8000 A5413	1	Assieme motore (TE 250)	Engine assy (TE 250)	Moteur complet (TE 250)	Motor kpl. (TE 250)	Motor compl. (TE 250)	
	16	8000 A5414	1	Assieme motore (TC 250)	Engine assy (TC 250)	Moteur complet (TC 250)	Motor kpl. (TC 250)	Motor compl. (TC 250)	
	16	8000 A5415	1	Assieme motore (400)	Engine assy (400)	Moteur complet (400)	Motor kpl. (400)	Motor compl. (400)	
	16	8000 A5416	1	Assieme motore (TE 450)	Engine assy (TE 450)	Moteur complet (TE 450)	Motor kpl. (TE 450)	Motor compl. (TE 450)	
	16	8000 A5417	1	Assieme motore (SMR 450)	Engine assy (SMR 450)	Moteur complet (SMR 450)	Motor kpl (SMR 450)	Motor compl. (SMR 450)	
	16	8000 A5418	1	Assieme motore (TC 450)	Engine assy (TC 450)	Moteur complet (TC 450)	Motor kpl. (TC 450)	Motor compl. (TC 450)	
	16	8000 A5419	1	Assieme motore (TE 510)	Engine assy (TE 510)	Moteur complet (TE 510)	Motor kpl. (TE 510)	Motor compl. (TE 510)	
	16	8000 A5420	1	Assieme motore (SMR 510)	Engine assy (SMR 510)	Moteur complet (SMR 510)	Motor kpl (SMR 510)	Motor compl. (SMR 510)	
	16	8000 A5421	1	Assieme motore (TC 510)	Engine assy (TC 510)	Moteur complet (TC 510)	Motor kpl. (TC 510)	Motor compl. (TC 510)	
	17	8000 62730	1	Vite (250-400-450)	Screw (250-400-450)	Vis (250-400-450)	Schraube (250-400-450)	Tornillo (250-400-450)	
	17	8E00 67545	1	Vite (510)	Screw (510)	Vis (510)	Schraube (510)	Tornillo (510)	
<b>&amp;</b>				Accoppiare a cilindro 8000 A4566	Coupling with cylinder 8000 A4566	Acoupler avec cylindre 8000 A4566	Verbinden mit Zylinder 8000 A4566	Acoplar con cilindro 8000 A4566	
<b>@</b>				Accoppiare a cilindro 8000 A6050	Coupling with cylinder 8000 A6050	Acoupler avec cylindre 8000 A6050	Verbinden mit Zylinder 8000 A6050	Acoplar con cilindro 8000 A6050	



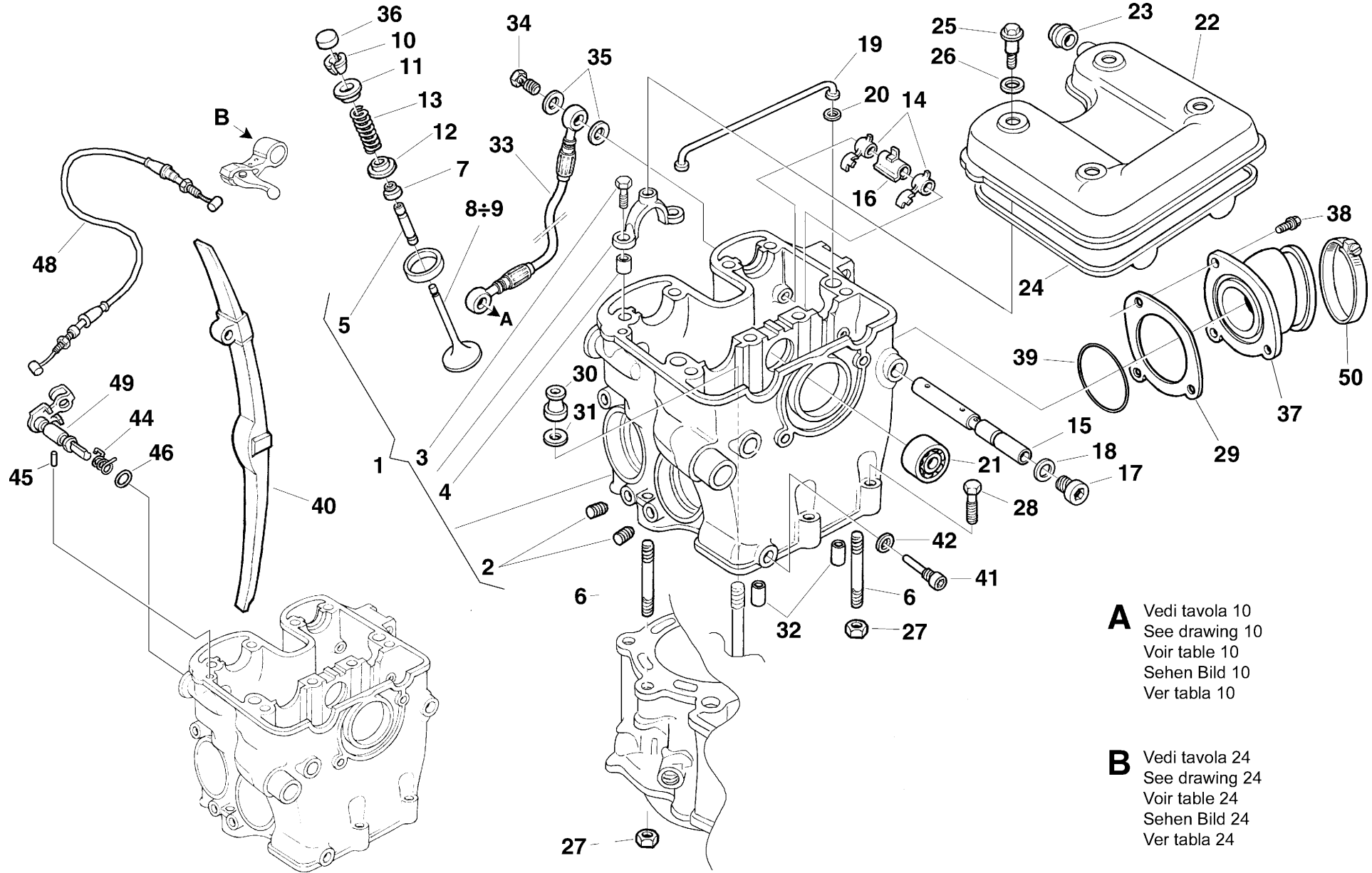

**A** Vedi tavola 10  
See drawing 10  
Voir table 10  
Sehen Bild 10  
Ver tabla 10

**B** Vedi tavola 24  
See drawing 24  
Voir table 24  
Sehen Bild 24  
Ver tabla 24

Note Notes Notas	Pos. No. N. Index Pos.	N. Cod. Code No. Nr. Code Code Nr N. Cod.	Q.tà Q.ty Q.te M.ge C.ad	DENOMINAZIONE	NAME	DESIGNATION	BESHREIBUNG	DENOMINACION	Validità Validity Validité Gültig Validez
	1	8000 A5308	1	Testa completa (250)	Cylinder head (250)	Culasse complete (250)	Zylinderkopf Kpl. (250)	Culata completa (250)	
	1	8A00 A5308	1	Testa completa (250) (U.S.A.-CDN)	Cylinder head (250) (U.S.A.-CDN)	Culasse complete (250) (U.S.A.-CDN)	Zylinderkopf Kpl. (250) (U.S.A.-CDN)	Culata completa (250) (U.S.A.-CDN)	
	1	8000 A4193	1	Testa completa (400)	Cylinder head (400)	Culasse complete (400)	Zylinderkopf Kpl. (400)	Culata completa (400)	
	1	8000 A5309	1	Testa completa (450-510)	Cylinder head (450-510)	Culasse compl. (450-510)	Zylinderkopf Kpl.(450-510)	Culata compl. (450-510)	
	1	8A00 A5309	1	Testa completa (450-510) (U.S.A.-CDN)	Cylinder head (450-510) (U.S.A.-CDN)	Culasse compl. (450-510) (U.S.A.-CDN)	Zylinderkopf Kpl.(450-510) (U.S.A.-CDN)	Culata compl. (450-510) (U.S.A.-CDN)	
	2	8000 49792	4	Heli-coil	Heli-coil	Heli-coil	Heli-coil	Heli-coil	
	3	8A00 85071	8	Vite (M6X25 mm)	Screw (M6X25 mm)	Vis (M6X25 mm)	Schraube (M6X25 mm)	Tornillo (M6X25 mm)	
	4	1617 95501	8	Bussola	Bushing	Douille	Buchse	Manguito	
	5	8000 A4152	4	Guidavalvola (250) Ø10,5	Valve guide (250) Ø10,5	Guide-soupape (250) Ø10,5	Ventilführung (250) Ø10,5	Guía-válvula (250) Ø10,5	
	5	8000 A4159	2	Guidavalvola Ø10,5 ASPIRAZIONE (400-450-510)	INLET Valve guide Ø10,5 (400-450-510)	Guide-soupape ADMISSION Ø10,5 (400-450-510)	EINLASS Ventilführung Ø10,5 (400-450-510)	Guía-válvula ASPIRACION Ø10,5 (400-450-510)	
	5	8000 A4158	2	Guidavalvola Ø10,5 SCARICO (400-450-510)	EXHAUST Valve guide Ø10,5 (400-450-510)	Guide-soupape Ø10,5 ECHAPPEMENT(400-450-510)	AUSLASS Ventilführung Ø10,5 (400-450-510)	Guía-válvula ESCAPE Ø10,5 (400-450-510)	
	6	8000 74836	2	Prigioniero (M8X51 mm)	Stud bolt (M8X51 mm)	Prisonnier (M8X51 mm)	Stiftschraube (M8X51 mm)	Prisionero (M8X51 mm)	
	7	8000 A4136	4	Anello di tenuta (250)	Seal ring (250)	Bague d'étanchéité (250)	Dichtungsring (250)	Anillo de retención (250)	
	7	8000 A4137	2	Anello di tenuta (400-450-510) ASPIRAZIONE	Seal ring (400-450-510) INLET	Bague d'étanchéité ADMISSION (400-450-510)	Dichtungsring (400-450-510) EINLASS	Anillo de retención ASPIRACION (400-450-510)	
	7	8000 A4136	2	Anello di tenuta (400-450-510) SCARICO	Seal ring (400-450-510) EXHAUST	Bague d'étanchéité ECHAP- PEMENT (400-450-510)	Dichtungsring (400-450-510) AUSLASS	Anillo de retención ESCAPE (400-450-510)	
	8	8000 A5439	2	Valvola aspirazione (250)	Inlet valve (250)	Soupape admission (250)	Einlass-Ventil (250)	Válvula aspiración (250)	
AW	8	8000 A5440	2	Valvola aspirazione (250)	Inlet valve (250)	Soupape admission (250)	Einlass-Ventil (250)	Válvula aspiración (250)	
	8	8000 A4631	2	Valvola aspirazione (400)	Inlet valve (400)	Soupape admission (400)	Einlass-Ventil (400)	Válvula aspiración (400)	
	8	8000 A5444	2	Valvola aspirazione (450-510)	Inlet valve (450-510)	Soupape admission (450-510)	Einlass-Ventil (450-510)	Válvula aspiración (450-510)	
AWM	8	8000 A5445	2	Valvola aspirazione (450-510)	Inlet valve (450-510)	Soupape admission (450-510)	Einlass-Ventil (450-510)	Válvula aspiración (450-510)	
	9	8000 A5438	2	Valvola scarico (250)	Exhaust valve (250)	Soupape d'échappement (250)	Auslass-Ventil (250)	Válvula de escape (250)	
AW	9	8000 A5441	2	Valvola scarico (250)	Exhaust valve (250)	Soupape d'échappement (250)	Auslass-Ventil (250)	Válvula de escape (250)	
	9	8000 A4161	2	Valvola scarico (400)	Exhaust valve (400)	Soupape d'échappement (400)	Auslass-Ventil (400)	Válvula de escape (400)	
	9	8000 A5442	2	Valvola scarico (450-510)	Exhaust valve (450-510)	Soupape d'échappement (450-510)	Auslass-Ventil (450-510)	Válvula de escape (450-510)	
AWM	9	8000 A5443	2	Valvola scarico (450-510)	Exhaust valve (450-510)	Soupape d'échappement (450-510)	Auslass-Ventil (450-510)	Válvula de escape (450-510)	

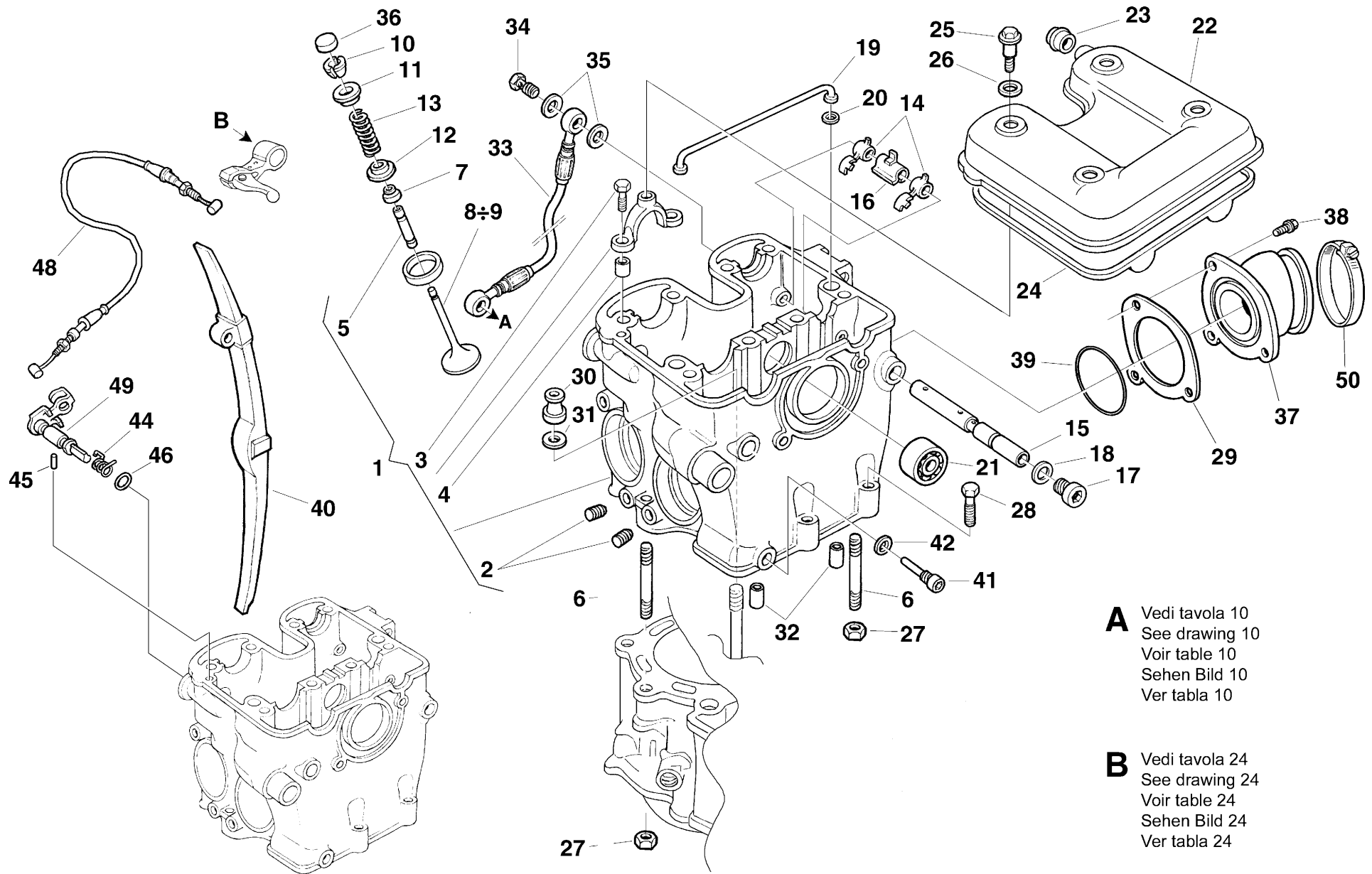

**A** Vedi tavola 10  
See drawing 10  
Voir table 10  
Sehen Bild 10  
Ver tabla 10

**B** Vedi tavola 24  
See drawing 24  
Voir table 24  
Sehen Bild 24  
Ver tabla 24

Note Notes Notas	Pos. No. N. Index Pos.	N. Cod. Code No. Nr. Code Code Nr N. Cod.	Q.tà Q.ty Q.te M.ge C.ad	DENOMINAZIONE	NAME	DESIGNATION	BESHREIBUNG	DENOMINACION	Validità Validity Validité Gültig Validez
	10	8000 A4106	8	Semicono (250)	Half cone (250)	Demi-cône (250)	Halb Kegel (250)	Semi-cono (250)	
	10	8000 A4107	4	Semicono (400-450-510) ASPIRAZIONE	Half cone (400-450-510) INLET	Demi-cône (400-450-510) ADMISSION	Halb Kegel (400-450-510) EINLASS	Semi-cono (400-450-510) ASPIRACION	
	10	8000 A4106	4	Semicono (400-450-510) SCARICO	Half cone (400-450-510) EXHAUST	Demi-cône (400-450-510) ECHAPPEMENT	Halb Kegel (400-450-510) AUSLASS	Semi-cono (400-450-510) ESCAPE	
	11	8000 A4151	4	Scodellino (250)	Cup (250)	Cuvette (250)	Teller (250)	Cubeta (250)	
	11	8000 A4157	2	Scodellino (400-450-510) ASPIRAZIONE	Cup (400-450-510) INLET	Cuvette (400-450-510) ADMISSION	Teller (400-450-510) EINLASS	Cubeta (400-450-510) ASPIRACION	
	11	8000 A4151	2	Scodellino (400-450-510) SCARICO	Cup (400-450-510) EXHAUST	Cuvette (400-450-510) ECHAPPEMENT	Teller (400-450-510) AUSLASS	Cubeta (400-450-510) ESCAPE	
	12	8000 91578	4	Piattello (250)	Cup (250)	Cuvette (250)	Teller (250)	Cubeta (250)	
	12	8000 A4135	2	Piattello (400-450-510) ASPIRAZIONE	Cup (400-450-510) INLET	Cuvette (400-450-510) ADMISSION	Teller (400-450-510) EINLASS	Cubeta (400-450-510) ASPIRACION	
	12	8000 91578	2	Piattello (400-450-510) SCARICO	Cup (400-450-510) EXHAUST	Cuvette (400-450-510) ECHAPPEMENT	Teller (400-450-510) AUSLASS	Cubeta (400-450-510) ESCAPE	
	13	8000 91579	4	Molla (250)	Spring (250)	Ressort (250)	Feder (250)	Resorte (250)	
	13	8000 A0568	4	Molla (400-450-510)	Spring (400-450-510)	Ressort (400-450-510)	Feder (400-450-510)	Resorte (400-450-510)	
	14	8000 91568	4	Bilanciere	Rocker-arm assy	Culbuteur	Kipphebel	Balancín	
	15	8000 A5436	2	Perno (250)	Pin (250)	Pivot (250)	Bolzen (250)	Perno (250)	
	15	8000 99833	2	Perno (400)	Pin (400)	Pivot (400)	Bolzen (400)	Perno (400)	
	15	8000 A5437	2	Perno (450-510)	Pin (450-510)	Pivot (450-510)	Bolzen (450-510)	Perno (450-510)	
	16	8000 A5435	1	Distanziale a molla (L=22,5mm) (250)	Spacer (L=22,5mm) (250)	Entretoise (L=22,5mm) (250)	Distanzstück (L=22,5mm) (250)	Separador (L=22,5mm) (250)	
	16	8A00 A5435	1	Distanziale a molla (L=23,5mm) (250)	Spacer (L=23,5mm) (250)	Entretoise (L=23,5mm) (250)	Distanzstück (L=23,5mm) (250)	Separador (L=23,5mm) (250)	
	16	8A00 91582	1	Distanziale a molla (L=25,8mm) (400)	Spacer (L=25,8 mm) (400)	Entretoise (L=25,8 mm) (400)	Distanzstück (L=25,8 mm) (400)	Separador (L=25,8 mm) (400)	
	16	8B00 91582	1	Distanziale a molla (L=27,8mm) (400)	Spacer (L=27,8 mm) (400)	Entretoise (L=27,8 mm) (400)	Distanzstück (L=27,8 mm) (400)	Separador (L=27,8 mm) (400)	
	16	8B00 A5435	1	Distanziale a molla (L=25,8mm) (450-510)	Spacer (L=25,8 mm) (450-510)	Entretoise (L=25,8 mm) (450-510)	Distanzstück (L=25,8 mm) (450-510)	Separador (L=25,8 mm) (450-510)	
	16	8C00 A5435	1	Distanziale a molla (L=30,8mm) (450-510)	Spacer (L=30,8 mm) (450-510)	Entretoise (L=30,8 mm) (450-510)	Distanzstück (L=30,8 mm) (450-510)	Separador (L=30,8 mm) (450-510)	

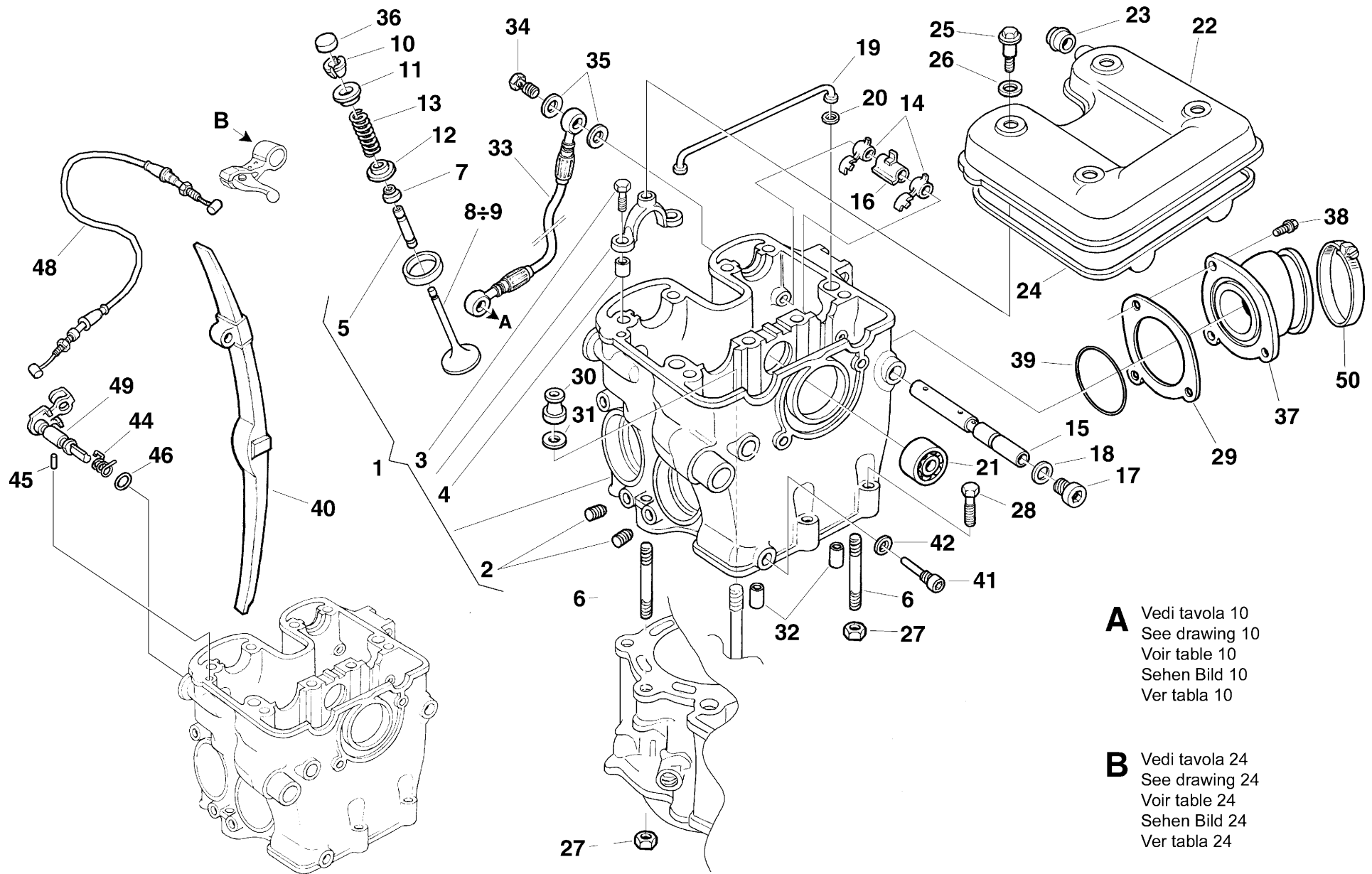

**A** Vedi tavola 10  
See drawing 10  
Voir table 10  
Sehen Bild 10  
Ver tabla 10

**B** Vedi tavola 24  
See drawing 24  
Voir table 24  
Sehen Bild 24  
Ver tabla 24



Note Notes Notas	Pos. No. Index Pos.	N. Cod. Code No. Nr. Code Code Nr N. Cod.	Q.tà Q.ty Q.te M.ge C.ad	DENOMINAZIONE	NAME	DESIGNATION	BESHREIBUNG	DENOMINACION	Validità Validity Validité Gültig Validez
	17	8000 99711	2	Tappo	Plug	Bouchon	Verschluss	Tapòn	
	18	8000 47763	2	Rosetta piana	Washer	Rondelle	Scheibe	Arandela	
	19	8000 91583	1	Tubetto olio (250)	Oil pipe (250)	Tuyau (250)	Rohr (250)	Tubo (250)	
	19	8000 99834	1	Tubetto olio (400-450-510)	Oil pipe (400-450-510)	Tuyau (400-450-510)	Rohr (400-450-510)	Tubo (400-450-510)	
	20	8000 91584	2	Anello OR	O-Ring	Bague OR	O-Ring	Anillo OR	
	21	8000 34317	1	Cuscinetto (ø12xø28x8 mm)	Bearing (ø12xø28x8 mm)	Roulement (ø12xø28x8 mm)	Lager (ø12xø28x8 mm)	Cojinete (ø12xø28x8 mm)	
	22	80A0 91548	1	Coperchio testa (250)	Cylinder head cover (250)	Couvercle culasse (250)	Zylinderkopf Deckel (250)	Tapa Culata (250)	
	22	80A0 99836	1	Coperchio testa (400-450-510)	Cyl.head cover (400-450-510)	Couv. culasse (400-450-510)	Zyl.Kopf Deckel(400-450-510)	Tapa Culata (400-450-510)	
	23	8000 91586	1	Raccordo sfiato	Union	Raccord	Anschluss	Empalme	
	24	8000 91566	1	Guarnizione (250)	Gasket (250)	Garnitue (250)	Dichtung (250)	Junta (250)	
	24	8000 99837	1	Guarnizione (400-450-510)	Gasket (400-450-510)	Garnitue (400-450-510)	Dichtung (400-450-510)	Junta (400-450-510)	
	25	8000 91587	4	Vite	Screw	Vis	Schraube	Tornillo	
	26	8000 91588	4	Rosetta di tenuta	Sealing washer	Rondelle	Scheibe	Arandela	
	27	8000 54700	2	Dado	Nut	Ecrou	Mutter	Tuerca	
	28	8000 62730	2	Vite (M6X30 mm)	Screw (M6X30 mm)	Vis (M6X30 mm)	Schraube (M6X30 mm)	Tornillo (M6X30 mm)	
	30	8000 91589	4	Dado	Nut	Ecrou	Mutter	Tuerca	
	31	8000 23374	4	Rosetta piana	Washer	Rondelle	Scheibe	Arandela	
	32	8000 47708	4	Bussola di riferimento	Bushing	Douille	Buchse	Manguito	
	33	8000 A0232	1	Tubo olio (250)	Oil pipe (250)	Tuyau (250)	Rohr (250)	Tubo (250)	
	33	8A00 A0232	1	Tubo olio (400-450-510)	Oil pipe (400-450-510)	Tuyau (400-450-510)	Rohr (400-450-510)	Tubo (400-450-510)	
	34	8000 A0574	2	Vite	Screw	Vis	Schraube	Tornillo	
	35	8000 A0575	4	Rosetta di tenuta	Sealing washer	Rondelle	Scheibe	Arandela	
	36	8000 A4162	4	Pastiglia (1,60 mm)	Pad (1,60 mm)	Plaquette (1,60 mm)	Belag (1,60 mm)	Pastilla (1,60 mm)	
	36	8A00 A4162	4	Pastiglia (1,65 mm)	Pad (1,65 mm)	Plaquette (1,65 mm)	Belag (1,65 mm)	Pastilla (1,65 mm)	
	36	8B00 A4162	4	Pastiglia (1,70 mm)	Pad (1,70 mm)	Plaquette (1,70 mm)	Belag (1,70 mm)	Pastilla (1,70 mm)	
	36	8C00 A4162	4	Pastiglia (1,75 mm)	Pad (1,75 mm)	Plaquette (1,75 mm)	Belag (1,75 mm)	Pastilla (1,75 mm)	
	36	8D00 A4162	4	Pastiglia (1,80 mm)	Pad (1,80 mm)	Plaquette (1,80 mm)	Belag (1,80 mm)	Pastilla (1,80 mm)	
	36	8E00 A4162	4	Pastiglia (1,85 mm)	Pad (1,85 mm)	Plaquette (1,85 mm)	Belag (1,85 mm)	Pastilla (1,85 mm)	
	36	8F00 A4162	4	Pastiglia (1,90 mm)	Pad (1,90 mm)	Plaquette (1,90 mm)	Belag (1,90 mm)	Pastilla (1,90 mm)	
	36	8G00 A4162	4	Pastiglia (1,95 mm)	Pad (1,95 mm)	Plaquette (1,95 mm)	Belag (1,95 mm)	Pastilla (1,95 mm)	
	36	8H00 A4162	4	Pastiglia (2,00 mm)	Pad (2,00 mm)	Plaquette (2,00 mm)	Belag (2,00 mm)	Pastilla (2,00 mm)	
	36	8J00 A4162	4	Pastiglia (2,05 mm)	Pad (2,05 mm)	Plaquette (2,05 mm)	Belag (2,05 mm)	Pastilla (2,05 mm)	
	36	8K00 A4162	4	Pastiglia (2,10 mm)	Pad (2,10 mm)	Plaquette (2,10 mm)	Belag (2,10 mm)	Pastilla (2,10 mm)	

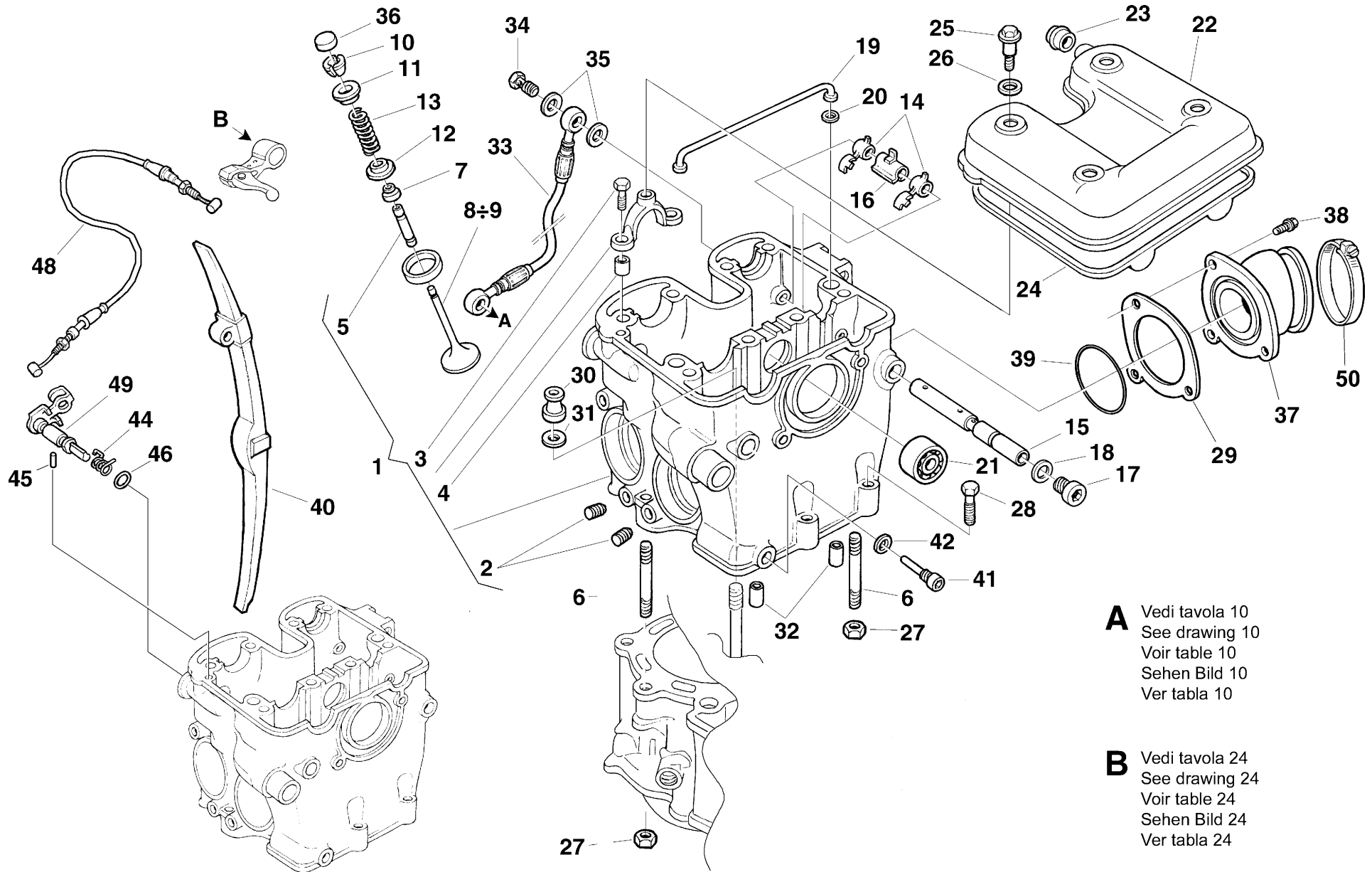

**A** Vedi tavola 10  
See drawing 10  
Voir table 10  
Sehen Bild 10  
Ver tabla 10

**B** Vedi tavola 24  
See drawing 24  
Voir table 24  
Sehen Bild 24  
Ver tabla 24

Note Notes Notas	Pos. No. N. Index Pos.	N. Cod. Code No. Nr. Code Code Nr N. Cod.	Q.tà Q.ty Q.te M.ge C.ad	DENOMINAZIONE	NAME	DESIGNATION	BESHREIBUNG	DENOMINACION	Validità Validity Validité Gültig Validez
	36	8L00 A4162	4	Pastiglia (2,15 mm)	Pad (2,15 mm)	Plaquette (2,15 mm)	Belag (2,15 mm)	Pastilla (2,15 mm)	
	36	8M00 A4162	4	Pastiglia (2,20 mm)	Pad (2,20 mm)	Plaquette (2,20 mm)	Belag (2,20 mm)	Pastilla (2,20 mm)	
	36	8N00 A4162	4	Pastiglia (2,25 mm)	Pad (2,25 mm)	Plaquette (2,25 mm)	Belag (2,25 mm)	Pastilla (2,25 mm)	
	36	8P00 A4162	4	Pastiglia (2,30 mm)	Pad (2,30 mm)	Plaquette (2,30 mm)	Belag (2,30 mm)	Pastilla (2,30 mm)	
	36	8R00 A4162	4	Pastiglia (2,35 mm)	Pad (2,35 mm)	Plaquette (2,35 mm)	Belag (2,35 mm)	Pastilla (2,35 mm)	
	36	8S00 A4162	4	Pastiglia (2,40 mm)	Pad (2,40 mm)	Plaquette (2,40 mm)	Belag (2,40 mm)	Pastilla (2,40 mm)	
	36	8T00 A4162	4	Pastiglia (2,45 mm)	Pad (2,45 mm)	Plaquette (2,45 mm)	Belag (2,45 mm)	Pastilla (2,45 mm)	
	36	8U00 A4162	4	Pastiglia (2,50 mm)	Pad (2,50 mm)	Plaquette (2,50 mm)	Belag (2,50 mm)	Pastilla (2,50 mm)	
	36	8V00 A4162	4	Pastiglia (2,55 mm)	Pad (2,55 mm)	Plaquette (2,55 mm)	Belag (2,55 mm)	Pastilla (2,55 mm)	
	36	8W00 A4162	4	Pastiglia (2,60 mm)	Pad (2,60 mm)	Plaquette (2,60 mm)	Belag (2,60 mm)	Pastilla (2,60 mm)	
	37	8000 A5737	1	Raccordo carburatore (250)	Union (250)	Raccord (250)	Anschluss (250)	Empalme (250)	
	37	8000 99887	1	Raccordo (400)	Union (400)	Raccord (400)	Anschluss (400)	Empalme (400)	
	37	8000 A5783	1	Raccordo (450-510)	Union (450-510)	Raccord (450-510)	Anschluss (450-510)	Empalme (450-510)	
	38	8000 62728	3	Vite (M6x20 mm)	Screw (M6x20 mm)	Vis (M6x20 mm)	Schraube (M6x20 mm)	Tornillo (M6x20 mm)	
	39	8000 19965	1	Anello OR	O-Ring	Bague OR	O-Ring	Anillo OR	
	40	8000 91553	1	Pattino catena	Chain slider	Glissière de chaine	Gleitbahn	Platode cadena	
	41	1615 35902	1	Vite	Screw	Vis	Schraube	Tornillo	
	42	8000 45194	1	Rosetta di tenuta	Sealing washer	Rondelle	Scheibe	Arandela	
	43	8000 93915	1	Raccordo (U.S.A.-CDN)	Union (U.S.A.-CDN)	Raccord (U.S.A.-CDN)	Anschluss (U.S.A.-CDN)	Empalme (U.S.A.-CDN)	
	44	8000 99687	1	Molla alzavalvole	Spring	Ressort	Feder	Resorte	
	45	8000 44298	1	Rullino	Roller	Aiguille	Rolle	Rodillo	
	46	8000 23107	1	Anello OR	O-Ring	Bague OR	O-Ring	Anillo OR	
	48	8A00 A0303	1	Trasmissione alzavalvole	Wire	Fil	Kabel	Transmision	
	49	8000 99684	1	Assieme alzavalvole	Valve lifter assy.	Groupe disp.décompression	Decompressionvorrichtung Kp	Gr. disp. decompression	
	50	8G00 99475	1	Fascetta (400)	Clamp (400)	Collier (400)	Schelle (400)	Abrazadera (400)	
	50	8000 A3774	1	Fascetta (250-450-510)	Clamp (250-450-510)	Collier (250-450-510)	Schelle (250-450-510)	Abrazadera (250-450-510)	

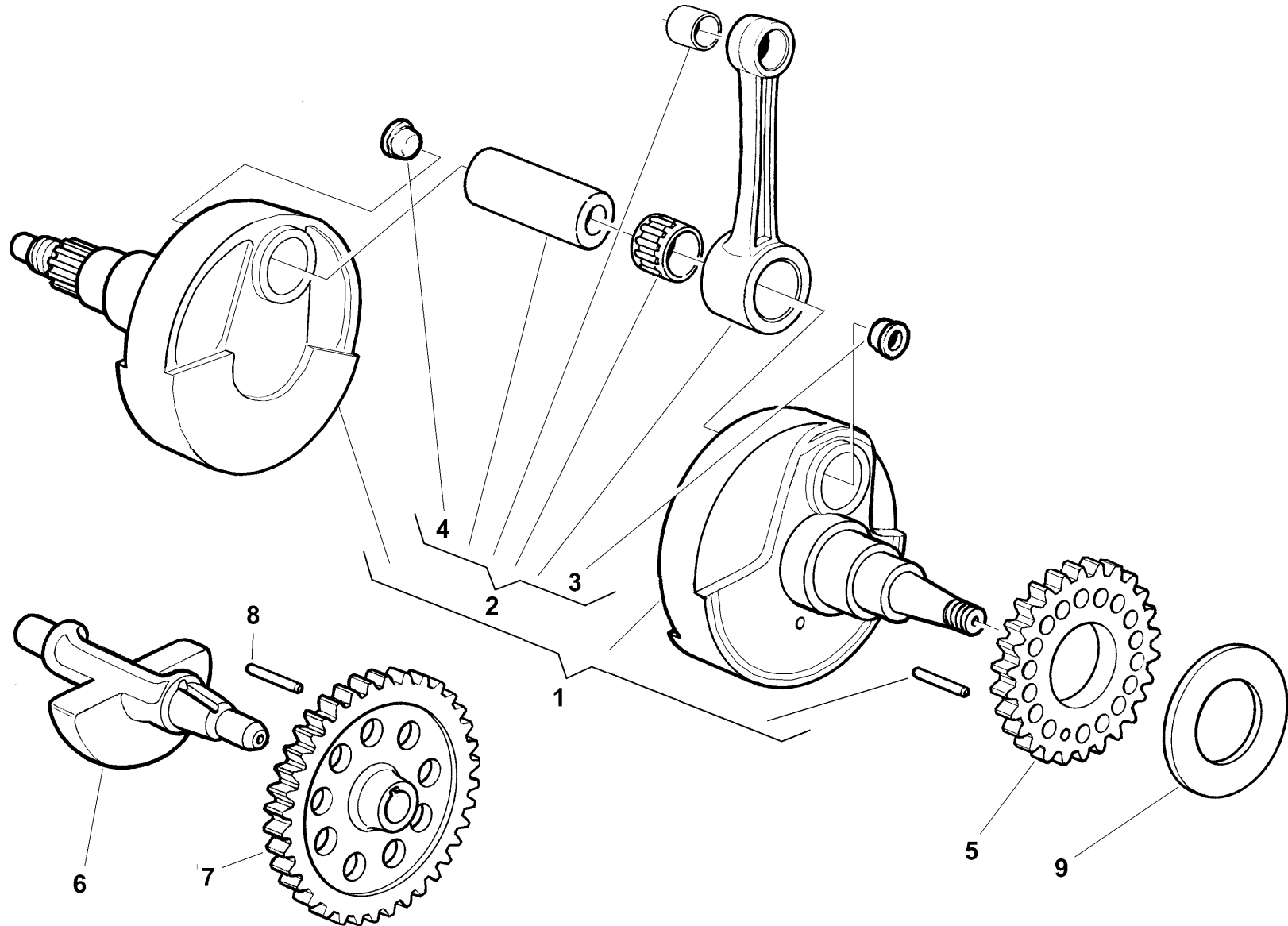

Note Notes Markes Notas	Pos. No. N. Index Pos.	N. Cod. Code No. Nr. Code Code Nr N. Cod.	Q.tà Q.ty Q.te M.ge C.ad	DENOMINAZIONE	NAME	DESIGNATION	BESHREIBUNG	DENOMINACION	Validità Validity Validité Gültig Validez
	1	8000 A6186	1	Albero motore compl. (250)	Crankshaft assy (250)	Vilebrequin compl. (250)	Kurbewelle kpl. (250)	Cigüeñal compl. (250)	
	1	8000 A4165	1	Alb. motore compl. (400-450)	Crankshaft assy (400-450)	Vilebrequin compl. (400-450)	Kurbewelle kpl. (400-450)	Cigüeñal compl. (400-450)	
	1	8000 A4178	1	Alb. motore compl. (510)	Crankshaft assy (510)	Vilebrequin compl. (510)	Kurbewelle kpl. (510)	Cigüeñal compl. (510)	
	2	8000 A5703	1	Biella completa (250)	Conrod assy. (250)	Bielle compl. (250)	Pleuelstange kpl. (250)	Biela motor completa (250)	
	2	8000 A4166	1	Biella completa (400-450)	Conrod assy. (400-450)	Bielle compl. (400-450)	Pleuelstange kpl. (400-450)	Biela motor compl. (400-450)	
	2	8000 A4179	1	Biella completa (510)	Conrod assy. (510)	Bielle compl. (510)	Pleuelstange kpl. (510)	Biela motor completa (510)	
	3	8B00 57196	1	Tappo (250)	Plug (250)	Bouchon (250)	Verschluss (250)	Tapòn (250)	
	3	8000 57196	1	Tappo (400-450-510)	Plug (400-450-510)	Bouchon (400-450-510)	Verschluss (400-450-510)	Tapòn (400-450-510)	
	4	8B00 57196	1	Tappo (250)	Plug (250)	Bouchon (250)	Verschluss (250)	Tapòn (250)	
	4	8000 57196	1	Tappo (400-450-510)	Plug (400-450-510)	Bouchon (400-450-510)	Verschluss (400-450-510)	Tapòn (400-450-510)	
<b>M</b>	5	8000 99915	1	Ingranaggio (Z=30)	Gear (Z=30)	Engrajage (Z=30)	Zahnrad (Z=30)	Engranaje (Z=30)	
<b>M</b>	6	8000 A4173	1	Contralbero (400-450)	Layshaft (400-450)	Arbre de bal. (400-450)	Worgelegewelle (400-450)	Contra eje (400-450)	
<b>M</b>	6	8000 A3435	1	Contralbero (510)	Layshaft (510)	Arbre de bal. (510)	Worgelegewelle (510)	Contra eje (510)	
<b>M</b>	7	8000 A4174	1	Ingranaggio (Z=30) (400-450)	Gear (Z=30) (400-450)	Engrajage (Z=30) (400-450)	Zahnrad (Z=30)(400-450)	Engranaje (Z=30) (400-450)	
<b>M</b>	7	8000 99916	1	Ingranaggio (Z=30) (510)	Gear (Z=30) (510)	Engrajage (Z=30) (510)	Zahnrad (Z=30) (510)	Engranaje (Z=30) (510)	
<b>M</b>	8	8A00 47773	1	Rullino	Roller	Aiguille	Rolle	Rodillo	
	9	8A00 28183	1	Rosetta di rasamento (0,3 mm)	Washer (0,3 mm)	Rondelle (0,3 mm)	Scheibe (0,3 mm)	Arandela (0,3 mm)	
	9	8C00 28183	1	Rosetta di rasamento (0,5 mm)	Washer (0,5 mm)	Rondelle (0,5 mm)	Scheibe (0,5 mm)	Arandela (0,5 mm)	
	9	8D00 28183	1	Rosetta di rasamento (0,6 mm)	Washer (0,6 mm)	Rondelle (0,6 mm)	Scheibe (0,6 mm)	Arandela (0,6 mm)	
	9	8F00 28183	1	Rosetta di rasamento (0,8 mm)	Washer (0,8 mm)	Rondelle (0,8 mm)	Scheibe (0,8 mm)	Arandela (0,8 mm)	
	9	8H00 28183	1	Rosetta di rasamento (1,0 mm)	Washer (1,0 mm)	Rondelle (1,0 mm)	Scheibe (1,0 mm)	Arandela (1,0 mm)	



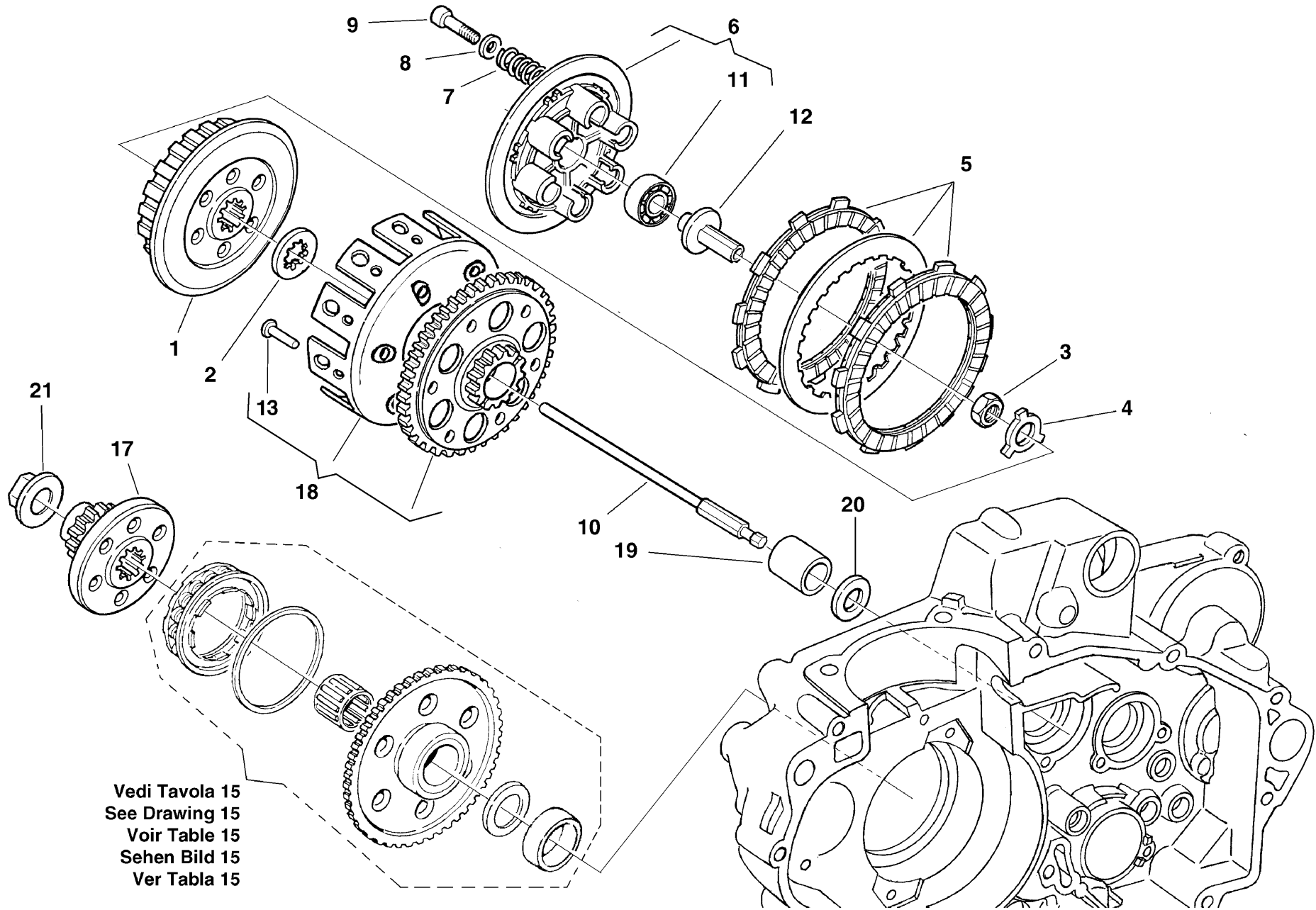

Vedi Tavola 15  
See Drawing 15  
Voir Table 15  
Sehen Bild 15  
Ver Tabla 15

Note Notes Marke Notas	Pos. No. N. Index Pos.	N. Cod. Code No. Nr. Code Code Nr N. Cod.	Q.tà Q.ty Q.te M.ge C.ad	DENOMINAZIONE	NAME	DESIGNATION	BESHREIBUNG	DENOMINACION	Validità Validity Validité Gültig Validez
	1	8C00 96746	1	Mozzo frizione (TE 250)	Hub (TE 250)	Moyeau (TE 250)	Radnabe (TE 250)	Cubo (TE 250)	
	1	8A00 A3801	1	Mozzo frizione (TE 450-510, TC, SM)	Hub (TE 450-510, TC, SM)	Moyeau (TE 450-510, TC, SM)	Radnabe (TE 450-510, TC, SM)	Cubo (TE 450-510, TC, SM)	
	2	8A00 38350	1	Rosetta (250)	Washer (250)	Rondelle (250)	Scheibe (250)	Arandela (250)	
	2	8000 38350	1	Rosetta (TE 450-510, TC, SM)	Washer (TE 450-510, TC, SM)	Rondelle (TE 450-510, TC, SM)	Scheibe (TE 450-510, TC, SM)	Arandela (TE 450-510, TC, SM)	
	3	8000 36856	1	Dado	Nut	Ecrou	Mutter	Tuerca	
	4	8000 36857	1	Rosetta	Washer	Rondelle	Scheibe	Arandela	
	5	8000 A0611	1	Ass. gr. dischi frizione (250)	Clutch group assy (250)	Gr. embrayage compl. (250)	Kupplungsgruppe Kpl (250)	Gr. embrague compl. (250)	
	5	8A00 A0611	1	Ass.gr.dischi frizione (TE 450-510, TC, SM)	Clutch group assy (TE 450-510, TC, SM)	Gr.embrayage compl. (TE 450-510, TC, SM)	Kupplungsgruppe Kpl (TE 450-510, TC, SM)	Gr.embrague compl. (TE 450-510, TC, SM)	
	6	8000 81508	1	Piastra spingidischi	Plate	Plaque	Platte	Placa	
	7	8000 A0730	6	Molla frizione	Clutch spring	Ressort embrayage	Kupplungsfeder	Resorte embrague	
	8	8000 81519	6	Scodellino	Cup	Cuvette	Teller	Cubeta	
	9	60N1 02510	6	Vite	Screw	Vis	Schraube	Tornillo	
	10	8000 99953	1	Astina disinnesto (TE 250, 400-450-510)	Control rod. (TE 250, 400-450-510)	Coulisseau (TE 250, 400-450-510)	Steuerstange (TE 250, 400-450-510)	Varilla (TE 250, 400-450-510)	
	10	8000 A2654	1	Astina disinnesto (TC 250)	Control rod (TC 250)	Coulisseau (TC 250)	Steuerstange (TC 250)	Varilla (TC 250)	
	11	8000 34317	1	Cuscinetto (ø12xø28x8 mm)	Bearing (ø12xø28x8 mm)	Roulement (ø12xø28x8 mm)	Lager (ø12xø28x8 mm)	Cojinete (ø12xø28x8 mm)	
	12	8000 A0882	1	Perno com. frizione (TE 250)	Pin (TE 250)	Pivot (TE 250)	Bolzen (TE 250)	Perno (TE 250)	
	12	8B00 A3509	1	Perno comando frizione (TE 450-510, TC, SM)	Pin (TE 450-510, TC, SM)	Pivot (TE 450-510, TC, SM)	Bolzen (TE 450-510, TC, SM)	Perno (TE 450-510, TC, SM)	
	13	8000 48236	8	Ribattino (400-450-510)	Rivet (400-450-510)	Rivet (400-450-510)	Niet (400-450-510)	Remache (400-450-510)	
W	17	8000 A3458	1	Ingr. conduttore (Z=24) (250)	Gear (Z=24) (250)	Engrantage (Z=24) (250)	Zahnrad (Z=24) (250)	Engranaje (Z=24) (250)	
C	17	8000 A6305	1	Ingr. conduttore (Z=24) (250)	Gear (Z=24) (250)	Engrantage (Z=24) (250)	Zahnrad (Z=24) (250)	Engranaje (Z=24) (250)	
	17	8000 A5921	1	Ingr.condutt.(Z=23) (400-450-510)	Gear (Z=23) (400-450-510)	Engrantage (Z=23) (400-450-510)	Zahnrad (Z=23) (400-450-510)	Engranaje (Z=23) (400-450-510)	
W	18	8000 A0751	1	Campana frizione compl. (250)	Clutch housing compl. (250)	Cage embrayage compl. (250)	Kupplungskorb kpl. (250)	Campana embrague compl. (250)	
C	18	8000 A6304	1	Campana frizione compl. (250)	Clutch housing compl. (250)	Cage embrayage compl. (250)	Kupplungskorb kpl. (250)	Campana embrague compl. (250)	
	18	8000 A5425	1	Campana frizione completa (400-450-510)	Clutch housing compl. (400-450-510)	Cage embrayage compl. (400-450-510)	Kupplungskorb kpl. (400-450-510)	Campana embrague compl. (400-450-510)	
	19	1615 38801	1	Bussola	Bushing	Douille	Buchse	Manguito	
	20	8E00 30053	1	Rosetta D38-d25,2	Washer D38-d25,2	Rondelle D38-d25,2	Scheibe D38-d25,2	Arandela D38-d25,2	

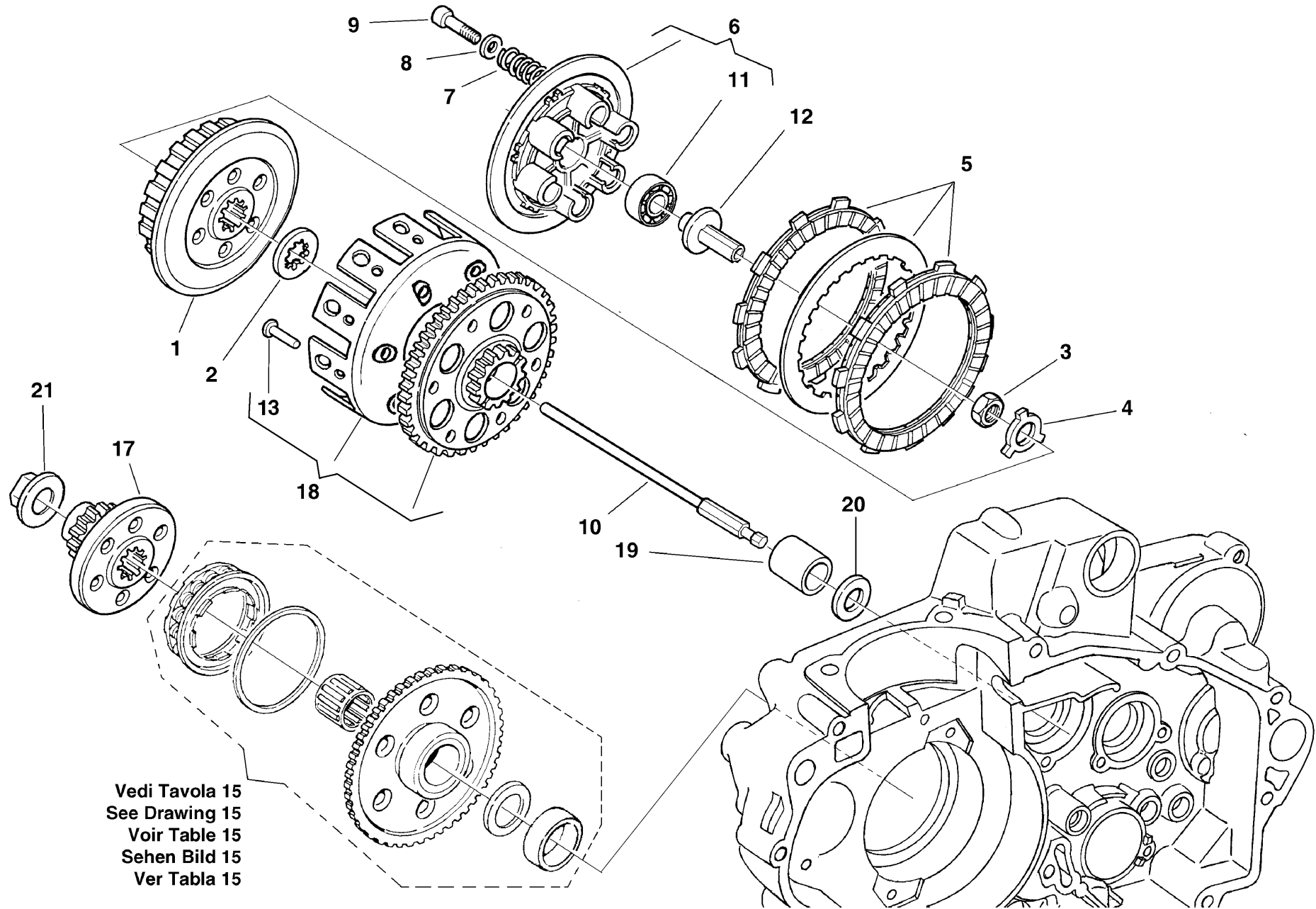

Vedi Tavola 15  
See Drawing 15  
Voir Table 15  
Sehen Bild 15  
Ver Tabla 15



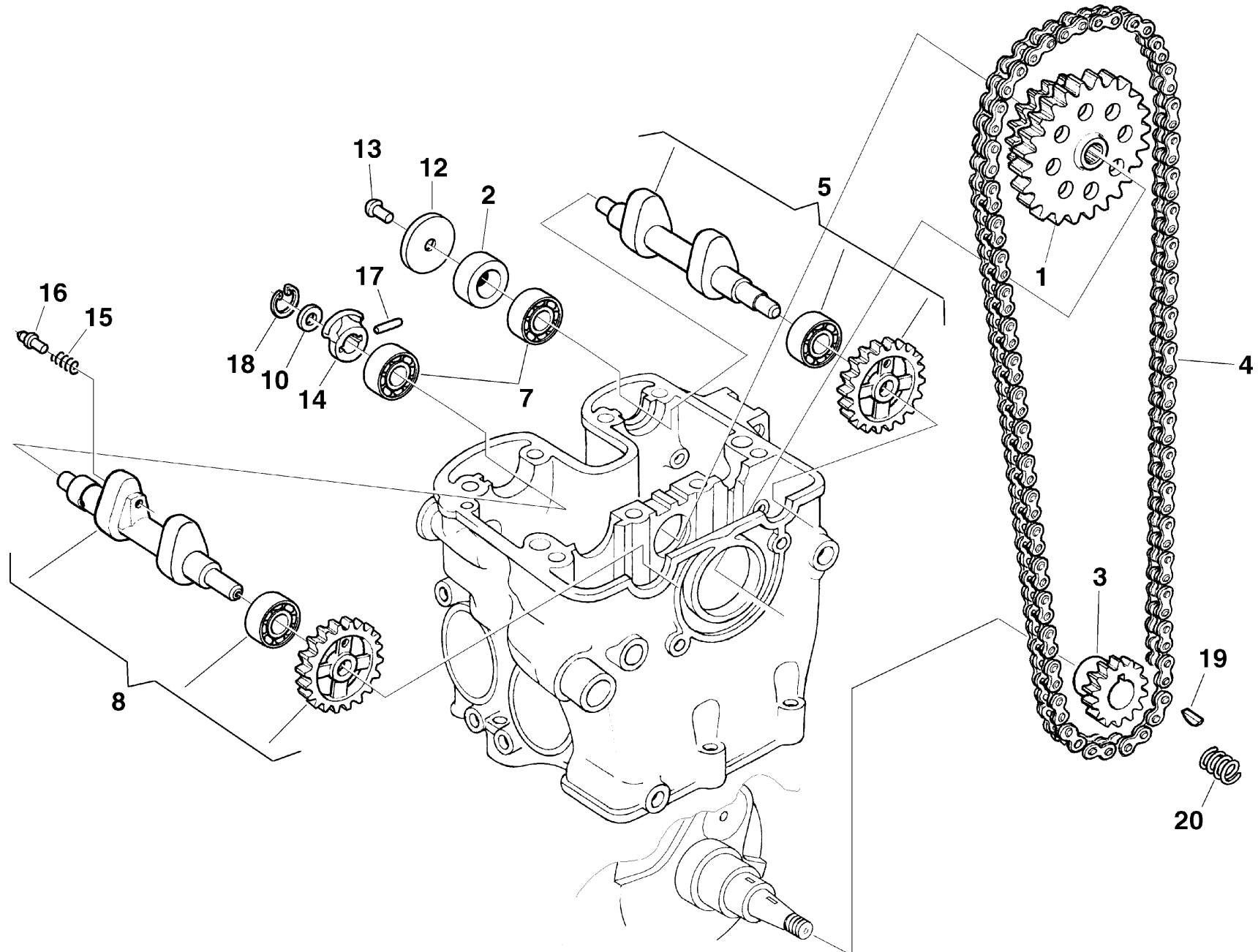



Note Notes Notas	Pos. No. N. Index Pos.	N. Cod. Code No. Nr. Code Code Nr N. Cod.	Q.tà Q.ty Q.te M.ge C.ad	DENOMINAZIONE	NAME	DESIGNATION	BESHREIBUNG	DENOMINACION	Validità Validity Validité Gültig Validez
	1	8000 A4791	1	Ingranaggio rinvio (Z=33/34) (250)	Gear (Z=33/34) (250)	Engranage (Z=33/34) (250)	Zahnrad (Z=33/34) (250)	Engranaje (Z=33/34) (250)	
\$	1	8000 A4790	1	Ingranaggio rinvio (Z=36/34) (400-450-510)	Gear (Z=36/34) (400-450)-510	Engranage (Z=36/34) (400-450-510)	Zahnrad (Z=36/34) (400-450-510)	Engranaje (Z=36/34) (400-450-510)	
	2	8000 A6271	1	Distanziale (250-450-510)	Spacer (250-450-510)	Entretoise (250-450-510)	Distanzstück (250-450-510)	Separador (250-450-510)	
	3	8C00 63811	1	Ingran. distribuzione (Z=17)	Gear (Z=17)	Engranage (Z=17)	Zahnrad (Z=17)	Engranaje (Z=17)	
	4	8F00 35794	1	Catena distribuzione (250) (88 maglie)	Chain (250) (88 link)	Chaîne (250) (88 maillon)	Kette (250) (88 Schake)	Cadena (250) (88 malla)	
	4	8C00 35794	1	Catena distribuzione (94 maglie) (400-450)	Chain (400-450) (94 link)	Chaîne (400-450) (94 maillon)	Kette (400-450) (94 Schake)	Cadena (400-450) (94 malla)	
	4	8B00 35794	1	Catena distribuzione (96 maglie) (510)	Chain (510) (96 link)	Chaîne (510) (96 maillon)	Kette (510) (96 Schake)	Cadena (510) (96 malla)	
	5	8000 A5592	1	Albero a camme ASPIRAZIONE (250)	Camshaft INTAKE (250)	Arbre distribution ADMISSION (250)	Nockenwelle ANSAUGSEITE (250)	Eje distribución ASPIRACIÓN (250)	
	5	8000 99877	1	Albero a camme ASPIRAZIONE (400)	Camshaft INTAKE (400)	Arbre distribution ADMISSION (400)	Nockenwelle ANSAUGSEITE (400)	Eje distribución ASPIRACIÓN (400)	
	5	8000 A5595	1	Albero a camme ASPIRAZIONE (450-510)	Camshaft INTAKE (450-510)	Arbre distribution ADMISSION (450-510)	Nockenwelle ANSAUGSEITE (450-510)	Eje distribución ASPIRACIÓN (450-510)	
	7	8000 34317	2	Cuscinetto (ø12xø28x8 mm)	Bearing (ø12xø28x8 mm)	Roulement (ø12xø28x8 mm)	Lager (ø12xø28x8 mm)	Cojinete (ø12xø28x8 mm)	
	8	8000 99694	1	Albero a camme SCARICO (250)	Camshaft EXHAUST (250)	Arbre distr. ECHAPPEMENT (250)	Nockenwelle AUSPUFFSEITE (250)	Eje distribución DESCARGA (250)	
	8	8000 99880	1	Albero a camme SCARICO (400)	Camshaft EXHAUST (400)	Arbre distr. ECHAPPEMENT (400)	Nockenwelle AUSPUFFSEITE (400)	Eje distribución DESCARGA (400)	
	8	8000 A4953	1	Albero a camme SCARICO (450-510)	Camshaft EXHAUST (450-510)	Arbre distr. ECHAPPEMENT (450-510)	Nockenwelle AUSPUFFSEITE (450-510)	Eje distribución DESCARGA (450-510)	
	10	8000 99702	1	Rosetta di rasamento	Washer	Rondelle	Scheibe	Arandela	
	12	8000 99703	1	Disco centrifugo	Disc	Disque	Scheibe	Disco	
	13	8000 62725	1	Vite (M6x10 mm) (400)	Screw (M6x10 mm) (400)	Vis (M6x10 mm) (400)	Schraube (M6x10 mm) (400)	Tornillo (M6x10 mm) (400)	
	13	8000 55699	1	Vite (250-450-510)	Screw (250-450-510)	Vis (250-450-510)	Schraube (250-450-510)	Tornillo (250-450-510)	
	14	8000 99698	1	Alzavalvola (250)	Valve lifter (250)	Levée de soupape (250)	Ventilauflheber (250)	Alzavalvula (250)	
	14	8000 A2242	1	Alzavalvola (400-450-510)	Valve lifter (400-450-510)	Levée de soupape (400-450-510)	Ventilauflheber (400-450-510)	Alzavalvula (400-450-510)	

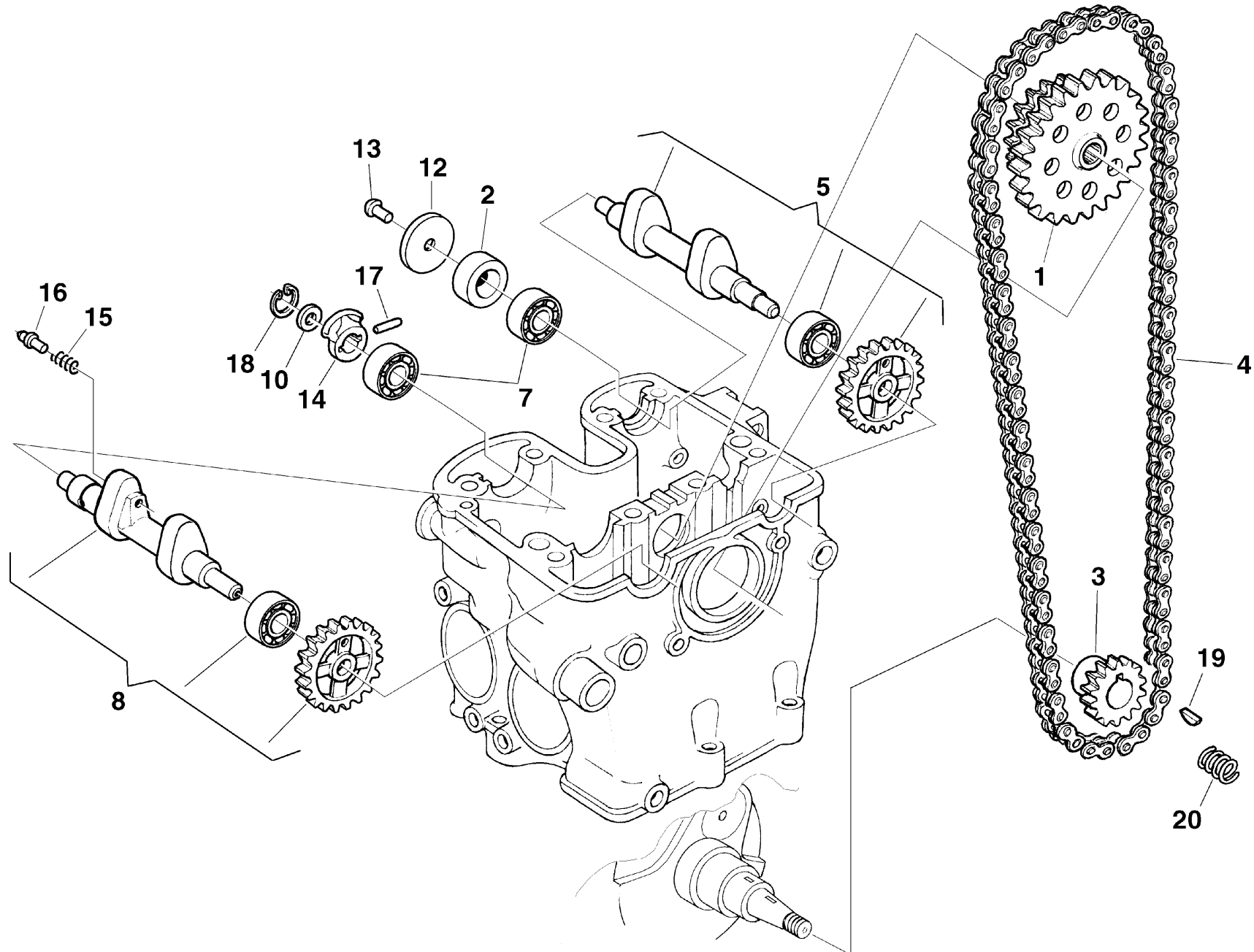

Note Notes Marke Notas	Pos. No. N. Index Pos.	N. Cod. Code No. Nr. Code Code Nr N. Cod.	Q.tà Q.ty Q.te M.ge C.ad	DENOMINAZIONE	NAME	DESIGNATION	BESHREIBUNG	DENOMINACION	Validità Validity Validité Gültig Validez
	15	8000 99699	1	Molla	Spring	Ressort	Feder	Resorte	
	16	8000 99700	1	Perno	Pin	Pivot	Bolzen	Perno	
	17	8000 99701	1	Rullino	Roller	Aiguille	Rolle	Rodillo	
	18	66N0 21205	1	Anello di fermo	Stop ring	Bague d'arrêt	Haltering	Anillo de retención	
	19	1615 09801	1	Chiavetta	Woodruff key	Clé woodruff	Federkeil	Lengüeta	
	20	8000 61275	1	Molla	Spring	Ressort	Feder	Resorte	

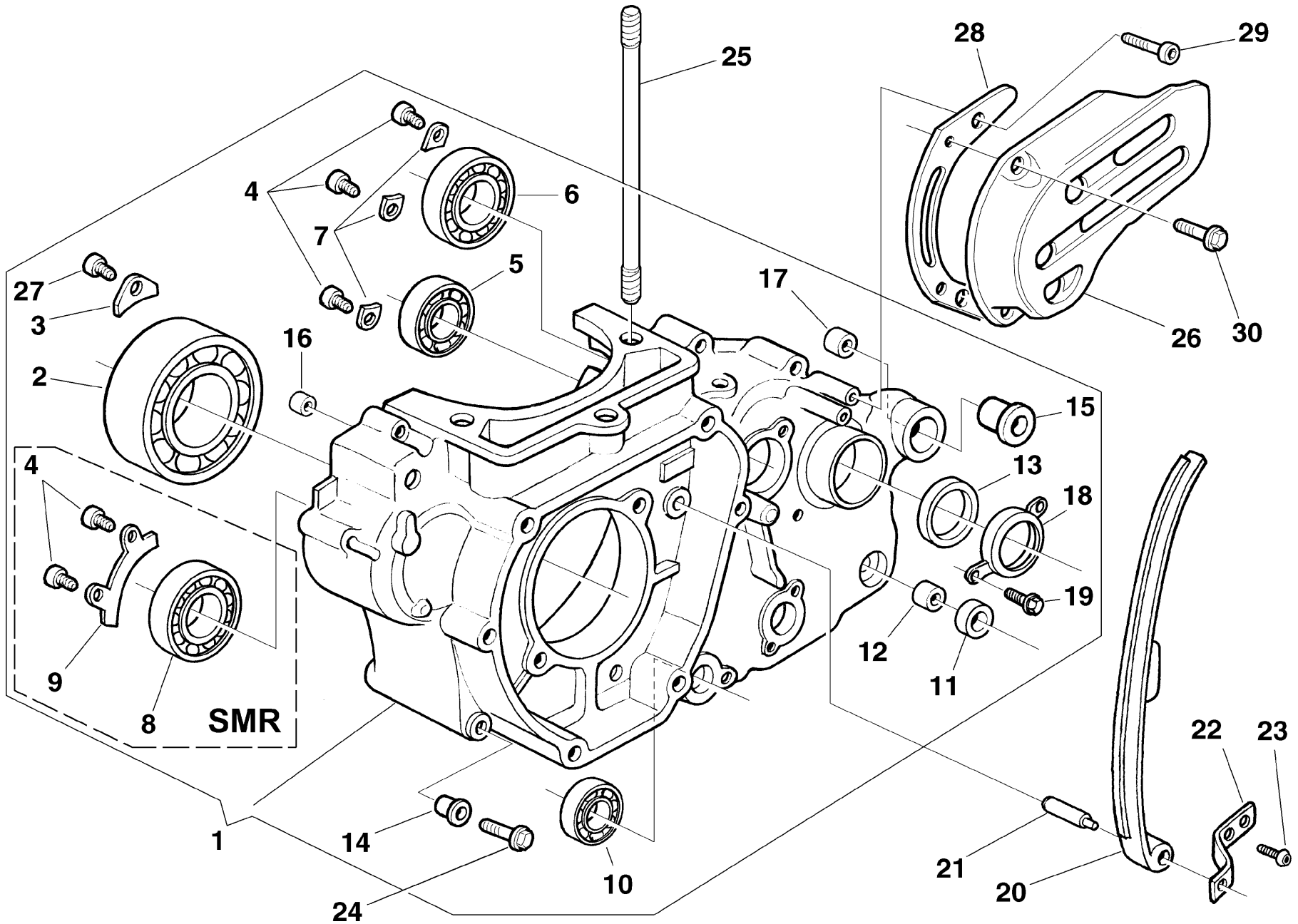

Note Notes Marke Notas	Pos. No. N. Index Pos.	N. Cod. Code No. Nr. Code Code Nr N. Cod.	Q.tà Q.ty Q.te M.ge C.ad	DENOMINAZIONE	NAME	DESIGNATION	BESHREIBUNG	DENOMINACION	Validità Validity Validité Gültig Validez
	1	8000 A5603	1	Carter motore accoppiati compl. (TE 250)	Crankcase assy (TE 250)	Carter compl. (TE 250)	Kurberlgehaue kpl. (TE 250)	Carter motor completi (TE 250)	
	1	8000 A6443	1	Carter motore accoppiati completi (TC 250)	Crankcase assy (TC 250)	Carter compl. (TC 250)	Kurberlgehaue kpl. (TC 250)	Carter motor completi (TC 250)	
<b>WM</b>	1	8000 A5671	1	Carter motore accoppiati compl. (400-450-510)	Crankcase assy (400-450-510)	Carter compl. (400-450-510)	Kurberlgehaue kpl. (400-450-510)	Carter motor completi (400-450-510)	
<b>C</b>	1	8000 A6445	1	Carter motore accoppiati completi (450-510)	Crankcase assy (450-510)	Carter compl. (450-510)	Kurberlgehaue kpl. (450-510)	Carter motor completi (450-510)	
	2	8000 A2767	1	Cuscinetto (ø30xø62x16 mm) ALBERO MOTORE (250)	Bearing (ø30xø62x16 mm) CRANKSHAFT (250)	Roulement (ø30xø62x16 mm) VILEBREQUIN (250)	Lager (ø30xø62x16 mm) KURBEWELLE (250)	Cojinete (ø30xø62x16 mm) CIGÜEÑAL (250)	
	2	8000 99846	1	Cuscinetto (ø30xø72x19 mm) ALBERO MOTORE (400-450-510)	Bearing (ø30xø72x19 mm) CRANKSHAFT (400-450-510)	Roulement (ø30xø72x19 mm) VILEBREQUIN (400-450-510)	Lager (ø30xø72x19 mm) KURBEWELLE (400-450-510)	Cojinete (ø30xø72x19 mm) CIGÜEÑAL (400-450-510)	
	3	8000 97941	2	Piastrina	Plate	Plaquette	Plättchen	Placa	
<b>M</b>	4	8A00 55241	5	Vite (M6X14 mm)	Screw (M6X14 mm)	Vis (M6X14 mm)	Schraube (M6X14 mm)	Tornillo (M6X14 mm)	
<b>WC</b>	4	8A00 55241	3	Vite (M6X14 mm)	Screw (M6X14 mm)	Vis (M6X14 mm)	Schraube (M6X14 mm)	Tornillo (M6X14 mm)	
	5	8000 99847	1	Cuscinetto (ø17xø40x12 mm) ALBERO PRIMARIO	Bearing (ø17xø40x12 mm) MAIN SHAFT	Roulement (ø17xø40x12 mm) ARBRE PRIMAIRE	Lager (ø17xø40x12 mm) HAUPTWELLE	Cojinete (ø17xø40x12 mm) EJE PRIMARIO	
	6	8000 43567	1	Cuscinetto (ø25xø52x15 mm) ALBERO SECONDARIO	Bearing (ø25xø52x15 mm) LAYSHAFT	Roulement (ø25xø52x15 mm) ARBRE SECONDAIRE	Lager (ø25xø52x15 mm) VORGELEGEWELLE	Cojinete (ø25xø52x15 mm) EJE SECUNDARIO	
	7	8000 51746	3	Piastrina	Plate	Plaquette	Plättchen	Placa	
<b>M</b>	8	8A00 19768	1	Cuscinetto (ø15xø42x13 mm) CONTRALBERO	Bearing (ø15xø42x13 mm) COUNTERSHAFT	Roulement (ø15xø42x13 mm) ARBRE DE BALAN.	Lager (ø15xø42x13 mm) WORGELEGEWELLE	Cojinete (ø15xø42x13 mm) CONTRA-EJE	
<b>M</b>	9	8000 91602	1	Piastrina	Plate	Plaquette	Plättchen	Placa	
	10	8000 65884	1	Cuscinetto (ø25xø37x7 mm) ALBERO COM. FORCELLE CAMBIO	Bearing (ø25xø37x7 mm) GEARBOX GEAR SHAFT	Roulement (ø25xø37x7 mm) ARBRE COMM. FOURCHES	Lager (ø25xø37x7 mm) ANTRIEBSWELLE SCHALTGABEL	Cojinete (ø25xø37x7 mm) EJE MANDO HORQUILLA CAMBIO	
	11	8000 34451	1	Anello di tenuta (ø12xø19x5 mm)	Seal ring (ø12xø19x5 mm)	Bague d'étanchéité (ø12xø19x5 mm)	Dichtungsring (ø12xø19x5 mm)	Anillo de retención (ø12xø19x5 mm)	
	12	8A00 65847	1	Bussola	Bushing	Douille	Buchse	Manguito	
	13	8000 59977	1	Anello di tenuta (ø32xø40x5 mm)	Seal ring (ø32xø40x5 mm)	Bague d'étanchéité (ø32xø40x5 mm)	Dichtungsring (ø32xø40x5 mm)	Anillo de retención (ø32xø40x5 mm)	
	14	1610 77703	2	Bussola	Bushing	Douille	Buchse	Manguito	

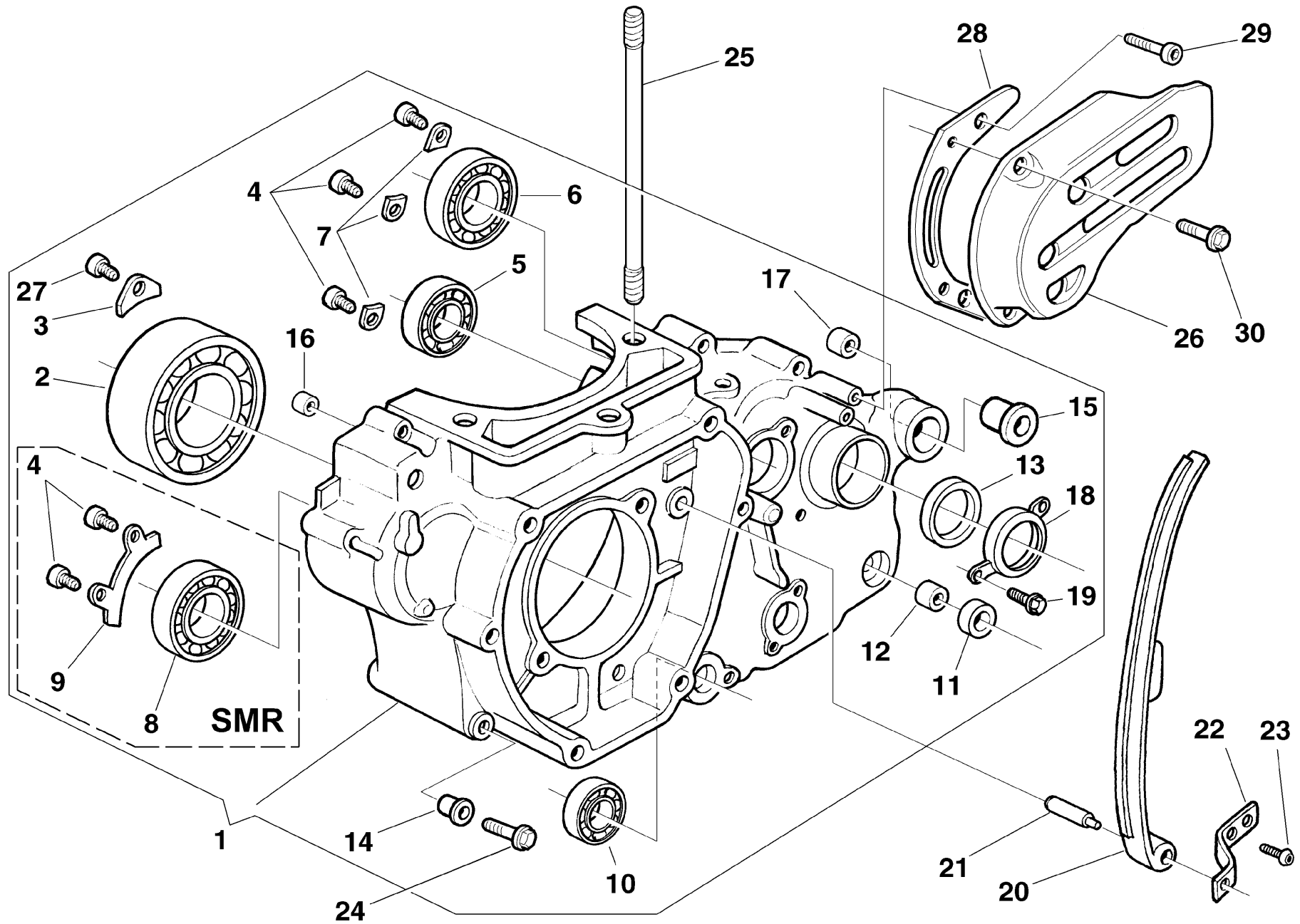



Note Notes Markes Notas	Pos. No. N. Index Pos.	N. Cod. Code No. Nr. Code Code Nr N. Cod.	Q.tà Q.ty Q.te M.ge C.ad	DENOMINAZIONE	NAME	DESIGNATION	BESHREIBUNG	DENOMINACION	Validità Validity Validité Gültig Validez
	15	8000 73500	1	Bussola	Bushing	Douille	Buchse	Manguito	
	16	1610 77601	1	Bussola	Bushing	Douille	Buchse	Manguito	
	17	1614 59002	1	Bussola	Bushing	Douille	Buchse	Manguito	
	18	8000 99850	1	Piastrina	Plate	Plaquette	Plättchen	Placa	
	19	8000 66525	2	Vite	Screw	Vis	Schraube	Tornillo	
	20	8000 91555	1	Pattino catena (250-400-450)	Chain slider (250-400-450)	Glissière de chaine (250-400-450)	Gleitbahn (250-400-450)	Platode cadena (250-400-450)	
	20	8000 A3504	1	Pattino catena (510)	Chain slider (510)	Glissière de chaine (510)	Gleitbahn (510)	Platode cadena (510)	
	21	8000 99704	1	Perno	Pin	Pivot	Bolzen	Perno	
	22	8000 99705	1	Piastrina	Plate	Plaquette	Plättchen	Placa	
	23	8000 66774	2	Vite	Screw	Vis	Schraube	Tornillo	
	24	8000 62731	12	Vite (M6X45 mm)	Screw (M6X45 mm)	Vis (M6X45 mm)	Schraube (M6X45 mm)	Tornillo (M6X45 mm)	
	25	8C00 81650	2	Prigioniero (M10x165 mm) (250)	Stud bolt (M10x165 mm) (250)	Prisonnier (M10x165 mm) (250)	Stiftschraube (M10x165 mm) (250)	Prisionero (M10x165 mm) (250)	
	25	8B00 81650	2	Prigioniero (M10x185 mm) (400-450)	Stud bolt (M10x185 mm) (400-450)	Prisonnier (M10x185 mm) (400-450)	Stiftschraube (M10x185 mm) (400-450)	Prisionero (M10x185 mm) (400-450)	
	25	8D00 81650	2	Prigioniero (M10x193 mm) (510)	Stud bolt (M10x193 mm) (510)	Prisonnier (M10x193 mm) (510)	Stiftschraube (M10x193 mm) (510)	Prisionero (M10x193 mm) (510)	
	26	8000 66973	1	Coperchio pignone catena	Pinion cover	Couvercle pignon	Ritzeldeckel	Tapa piñón	
	27	8A00 55241	2	Vite M6X14 mm (250)	Screw M6X14 mm (250)	Vis M6X14 mm (250)	Schraube M6X14 mm (250)	Tornillo M6X14 mm (250)	
	27	8000 28327	2	Vite M6X14 mm (400-450-510)	Screw M6X14 mm (400-450-510)	Vis M6X14 mm (400-450-510)	Schraube M6X14 mm (400-450-510)	Tornillo M6X14 mm (400-450-510)	
	28	8000 A0663	1	Piastra guidacatena	Plate	Plaquette	Plättchen	Placa	
	29	8A00 55241	2	Vite (M6x14 mm)	Screw (M6x14 mm)	Vis (M6x14 mm)	Schraube (M6x14 mm)	Tornillo (M6x14 mm)	
	30	8000 62725	2	Vite (M6x10 mm)	Screw (M6x10 mm)	Vis (M6x10 mm)	Schraube (M6x10 mm)	Tornillo (M6x10 mm)	

Vedi Tavola 12  
See Drawing 12  
Voir Table 12  
Sehen Bild 12  
Ver Tabla12

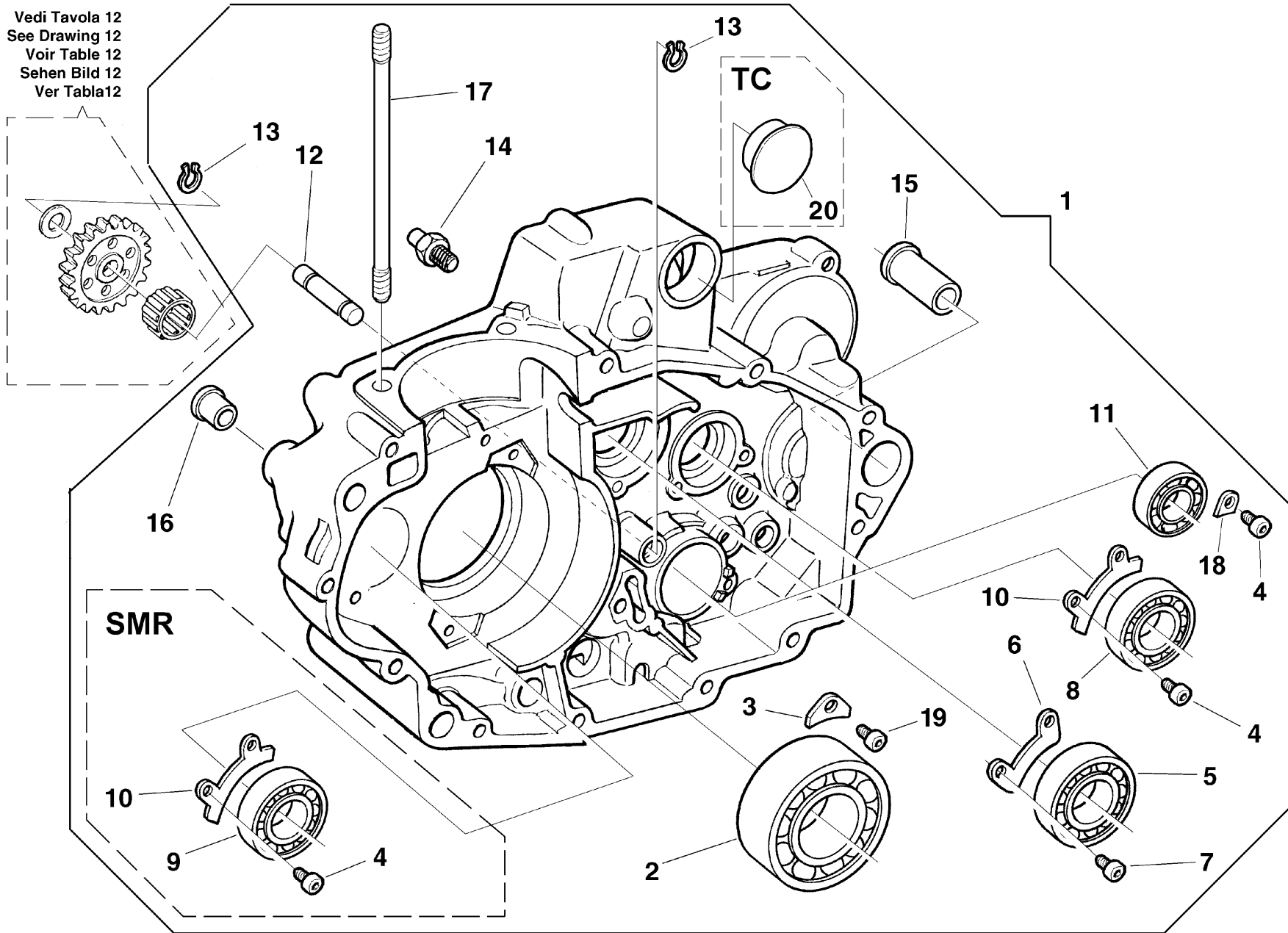

Note Notes Marke Notas	Pos. No. N. Index Pos.	N. Cod. Code No. Nr. Code Code Nr N. Cod.	Q.tà Q.ty Q.te M.ge C.ad	DENOMINAZIONE	NAME	DESIGNATION	BESHREIBUNG	DENOMINACION	Validità Validity Validité Gültig Validez
	1	8000 A5603	1	Carter motore accoppiati compl. (TE 250)	Crankcase assy (TE 250)	Carter compl. (TE 250)	Kurberlgehaue kpl. (TE 250)	Carter motor completi (TE 250)	
	1	8000 A6443	1	Carter motore accoppiati completi (TC 250)	Crankcase assy (TC 250)	Carter compl. (TC 250)	Kurberlgehaue kpl. (TC 250)	Carter motor completi (TC 250)	
<b>WM</b>	1	8000 A5671	1	Carter motore accoppiati compl. (400-450-510)	Crankcase assy (400-450-510)	Carter compl. (400-450-510)	Kurberlgehaue kpl. (400-450-510)	Carter motor completi (400-450-510)	
<b>C</b>	1	8000 A6445	1	Carter motore accoppiati completi (450-510)	Crankcase assy (450-510)	Carter compl. (450-510)	Kurberlgehaue kpl. (450-510)	Carter motor completi (450-510)	
	2	8000 A2767	1	Cuscinetto (ø30xø62x16 mm) ALBERO MOTORE (250)	Bearing (ø30xø62x16 mm) CRANKSHAFT (250)	Roulement (ø30xø62x16 mm) VILEBREQUIN (250)	Lager (ø30xø62x16 mm) KURBEWELLE (250)	Cojinete (ø30xø62x16 mm) CIGÜEÑAL (250)	
	2	8000 99846	1	Cuscinetto (ø30xø72x19 mm) ALBERO MOTORE (400-450-510)	Bearing (ø30xø72x19 mm) CRANKSHAFT (400-450-510)	Roulement (ø30xø72x19 mm) VILEBREQUIN (400-450-510)	Lager (ø30xø72x19 mm) KURBEWELLE (400-450-510)	Cojinete (ø30xø72x19 mm) CIGÜEÑAL (400-450-510)	
	3	8000 97941	2	Piastrina	Plate	Plaquette	Plättchen	Placa	
<b>M</b>	4	8A00 55241	5	Vite	Screw	Vis	Schraube	Tornillo	
<b>WC</b>	4	8A00 55241	3	Vite	Screw	Vis	Schraube	Tornillo	
	5	8000 24952	1	Cuscinetto (ø25xø52x15 mm) ALBERO PRIMARIO	Bearing (ø25xø52x15 mm) MAIN SHAFT	Roulement (ø25xø52x15 mm) ARBRE PRIMAIRE	Lager (ø25xø52x15 mm) HAUPTWELLE	Cojinete (ø25xø52x15 mm) EJE PRIMARIO	
	6	8A00 42100	1	Piastrina	Plate	Plaquette	Plättchen	Placa	
	7	8B00 55241	2	Vite	Screw	Vis	Schraube	Tornillo	
	8	8000 17040	1	Cuscinetto (ø20xø42x12 mm) ALBERO SECONDARIO	Bearing (ø20xø42x12 mm) LAYSHAFT	Roulement (ø20xø42x12 mm) ARBRE SECONDAIRE	Lager (ø20xø42x12 mm) VORGELEGEWELLE	Cojinete (ø20xø42x12 mm) EJE SECUNDARIO	
<b>M</b>	9	8A00 19768	1	Cuscinetto (ø15xø42x13 mm) CONTRALBERO	Bearing (ø15xø42x13 mm) COUNTERSHAFT	Roulement (ø15xø42x13 mm) ARBRE DE BALAN.	Lager (ø15xø42x13 mm) WORGELEGEWELLE	Cojinete (ø15xø42x13 mm) CONTRA-EJE	
<b>M</b>	10	8000 91602	2	Piastrina	Plate	Plaquette	Plättchen	Placa	
<b>WC</b>	10	8000 91602	1	Piastrina	Plate	Plaquette	Plättchen	Placa	
	11	8000 85395	1	Cuscinetto (ø25xø42x9 mm) ALBERO COM. FORCELLE CAMBIO	Bearing (ø25xø42x9 mm) GEARBOX GEAR SHAFT	Roulement (ø25xø42x9 mm) ARBRE COMM. FOURCHES	Lager (ø25xø42x9 mm) ANTRIEBSWELLE SCHALTGABEL	Cojinete (ø25xø42x9 mm) EJE MANDO HORQUILLA CAMBIO	
	12	8000 A5662	1	Perno	Pin	Pivot	Bolzen	Perno	
	13	66NO 21312	2	Anello di fermo	Stop ring	Bague d'arrêt	Haltering	Anillo de retención	
	14	8B00 66953	1	Perno fermo selettore	Pin	Pivot	Bolzen	Perno	
	15	8000 73500	1	Bussola	Bushing	Douille	Buchse	Manguito	

Vedi Tavola 12  
See Drawing 12  
Voir Table 12  
Sehen Bild 12  
Ver Tabla12

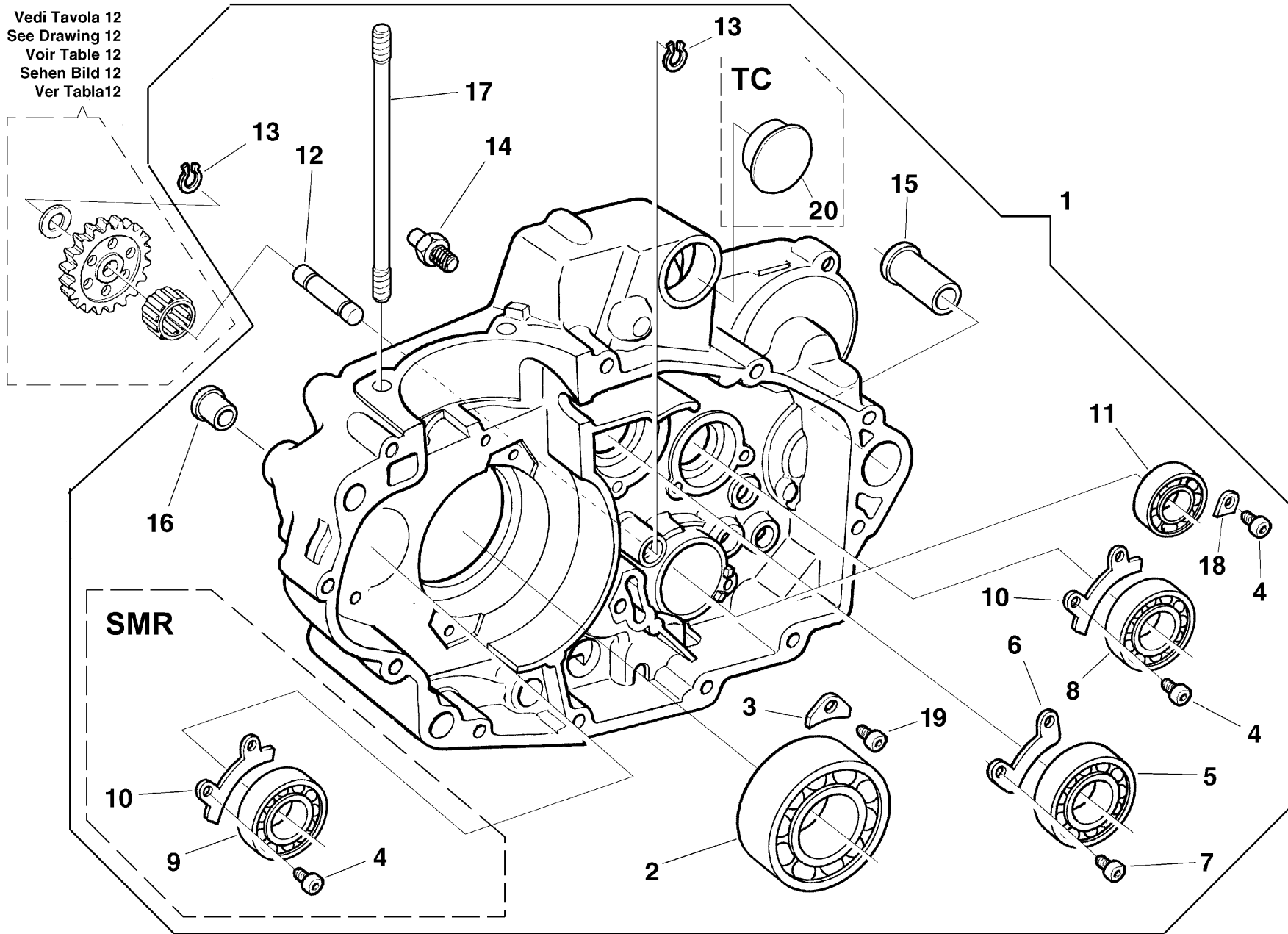

Note Notes Marke Notas	Pos. No. N. Index Pos.	N. Cod. Code No. Nr. Code Code Nr N. Cod.	Q.tà Q.ty Q.te M.ge C.ad	DENOMINAZIONE	NAME	DESIGNATION	BESHREIBUNG	DENOMINACION	Validità Validity Validité Gültig Validez
	16	1610 77703	2	Bussola	Bushing	Douille	Buchse	Manguito	
	17	8C00 81650	2	Prigioniero (M10x165 mm) (250)	Stud bolt (M10x165 mm) (250)	Prisonnier (M10x165 mm) (250)	Stiftschraube (M10x165 mm) (250)	Prisionero (M10x165 mm) (250)	
	17	8B00 81650	2	Prigioniero (M10x185 mm) (400-450)	Stud bolt (M10x185 mm) (400-450)	Prisonnier (M10x185 mm) (400-450)	Stiftschraube (M10x185 mm) (400-450)	Prisionero (M10x185 mm) (400-450)	
	17	8D00 81650	2	Prigioniero (M10x193 mm) (510)	Stud bolt (M10x193 mm) (510)	Prisonnier (M10x193 mm) (510)	Stiftschraube (M10x193 mm) (510)	Prisionero (M10x193 mm) (510)	
	18	8000 51746	1	Piastrina	Plate	Plaquette	Plättchen	Placa	
	19	8A00 55241	2	Vite M6X14 mm (250)	Screw M6X14 mm (250)	Vis M6X14 mm (250)	Schraube M6X14 mm (250)	Tornillo M6X14 mm (250)	
	19	8000 28327	2	Vite M6X14 mm (400-450-510)	Screw M6X14 mm (400-450-510)	Vis M6X14 mm (400-450-510)	Schraube M6X14 mm (400-450-510)	Tornillo M6X14 mm (400-450-510)	
<b>C</b>	20	8000 A6469	1	Tappo	Plug	Bouchon	Verschluss	Tapòn	

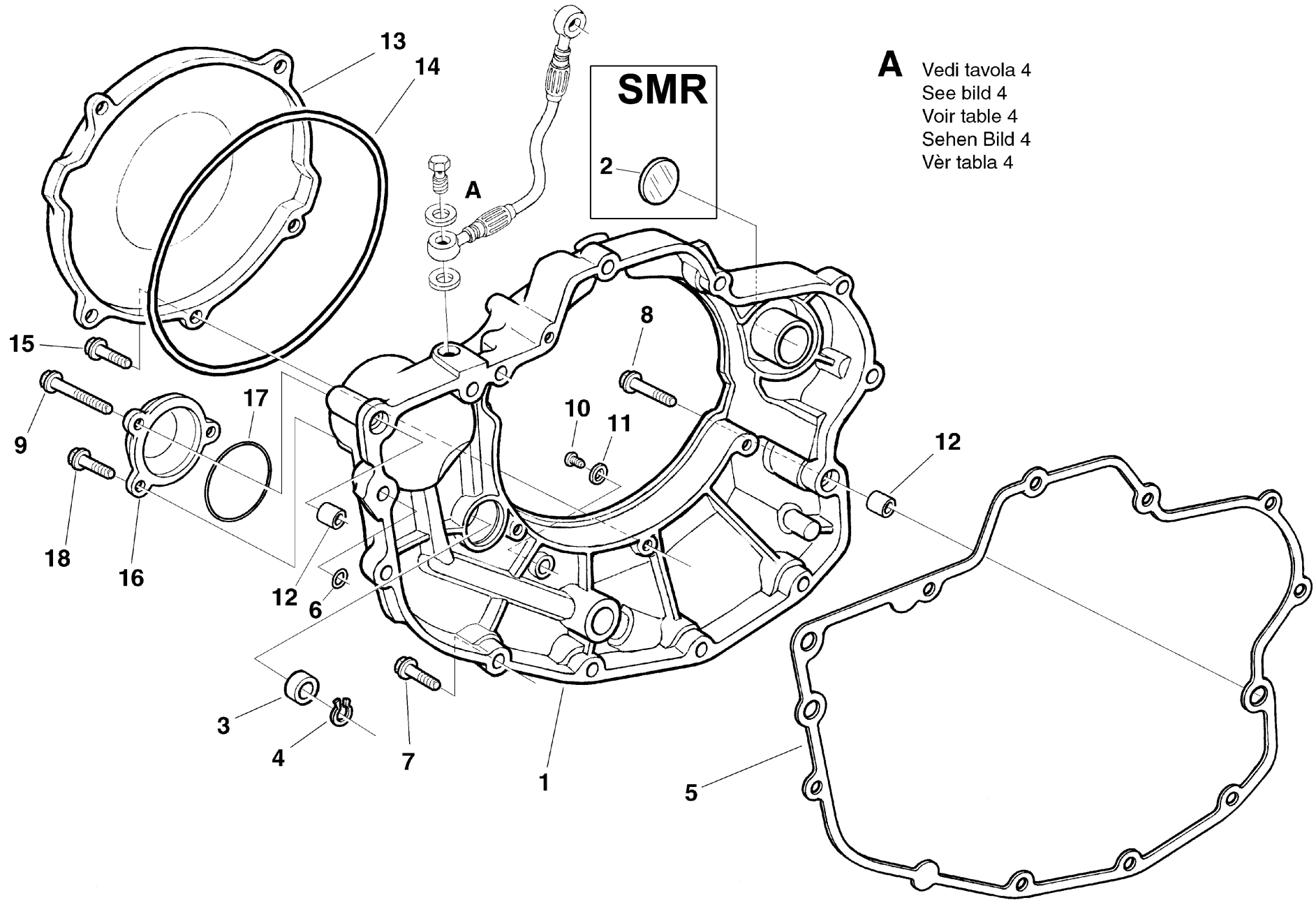

**A** Vedi tavola 4  
See bild 4  
Voir table 4  
Sehen Bild 4  
Vèr tabla 4



Note Notes Notas	Pos. No. N. Index Pos.	N. Cod. Code No. Nr. Code Code Nr N. Cod.	Q.tà Q.ty Q.te M.ge C.ad	DENOMINAZIONE	NAME	DESIGNATION	BESHREIBUNG	DENOMINACION	Validità Validity Validité Gültig Validez
	1	80A0 A5905	1	Coperchio destro	R.H. Cover	Couvercle D.	R. Deckel	Tapa DER.	
<b>M</b>	2	8000 A0765	1	Tappo	Plug	Bouchon	Verschluss	Tapòn	
	3	8A00 28855	1	Anello di tenuta (ø12xØ22x6,5 mm)	Seal ring (ø12xØ22x6,5 mm)	Bague d'étanchéité (ø12xØ22x6,5 mm)	Dichtungsring (ø12xØ22x6,5 mm)	Anillo de retención (ø12xØ22x6,5 mm)	
	4	66N0 21258	1	Anello di fermo	Stop ring	Bague d'arrêt	Haltering	Anillo de retención	
	5	8000 A5906	1	Guarnizione	Gasket	Garnitue	Dichtung	Junta	
	6	8000 99855	1	Anello OR	O-Ring	Bague OR	O-Ring	Anillo OR	
	7	8000 62729	10	Vite (M6X25 mm)	Screw (M6X25 mm)	Vis (M6X25 mm)	Schraube (M6X25 mm)	Tornillo (M6X25 mm)	
	8	8A00 67545	1	Vite (M6X35 mm)	Screw (M6X35 mm)	Vis (M6X35 mm)	Schraube (M6X35 mm)	Tornillo (M6X35 mm)	
	9	8F00 67545	1	Vite (M6X80 mm)	Screw (M6X80 mm)	Vis (M6X80 mm)	Schraube (M6X80 mm)	Tornillo (M6X80 mm)	
	10	8S00 67545	1	Vite	Screw	Vis	Schraube	Tornillo	
	11	8A00 15960	1	Rosetta piana	Washer	Rondelle	Scheibe	Arandela	
	12	8000 07719	2	Bussola	Bushing	Douille	Buchse	Manguito	
	13	80A0 A5931	1	Coperchio frizione (TE 250)	Clutch cover (TE 250)	Couvercle embrayage (TE 250)	Kupplungdeckel (TE 250)	Tapa embrague (TE 250)	
	13	80A0 A5934	1	Coperchio frizione (TC 250, 400-450-510)	Clutch cover (TC 250, 400-450-510)	Couvercle embrayage (TC 250, 400-450-510)	Kupplungdeckel (TC 250, 400-450-510)	Tapa embrague (TC 250, 400-450-510)	
<b>E</b>	13	80A0 A3506	1	Coperchio frizione (510)	Clutch cover (510)	Couvercle embrayage (510)	Kupplungdeckel (510)	Tapa embrague (510)	
	14	8000 86878	1	Anello OR	O-Ring	Bague OR	O-Ring	Anillo OR	
	15	8000 62728	5	Vite (M6X20 mm) (250)	Screw (M6X20 mm) (250)	Vis (M6X20 mm) (250)	Schraube (M6X20 mm) (250)	Tornillo (M6X20 mm) (250)	
	15	8000 62730	5	Vite (M6X30 mm) (400-450-510)	Screw (M6X30 mm) (400-450-510)	Vis (M6X30 mm) (400-450-510)	Schraube (M6X30 mm) (400-450-510)	Tornillo (M6X30 mm) (400-450-510)	
	16	80A0 91551	1	Coperchio filtro olio	Oil filter cover	Couvercle filtre huile	Deckel	Tapa	
	17	8A00 28553	1	Anello OR	O-Ring	Bague OR	O-Ring	Anillo OR	
	18	8000 62728	2	Vite (M6X20 mm)	Screw (M6X20 mm)	Vis (M6X20 mm)	Schraube (M6X20 mm)	Tornillo (M6X20 mm)	

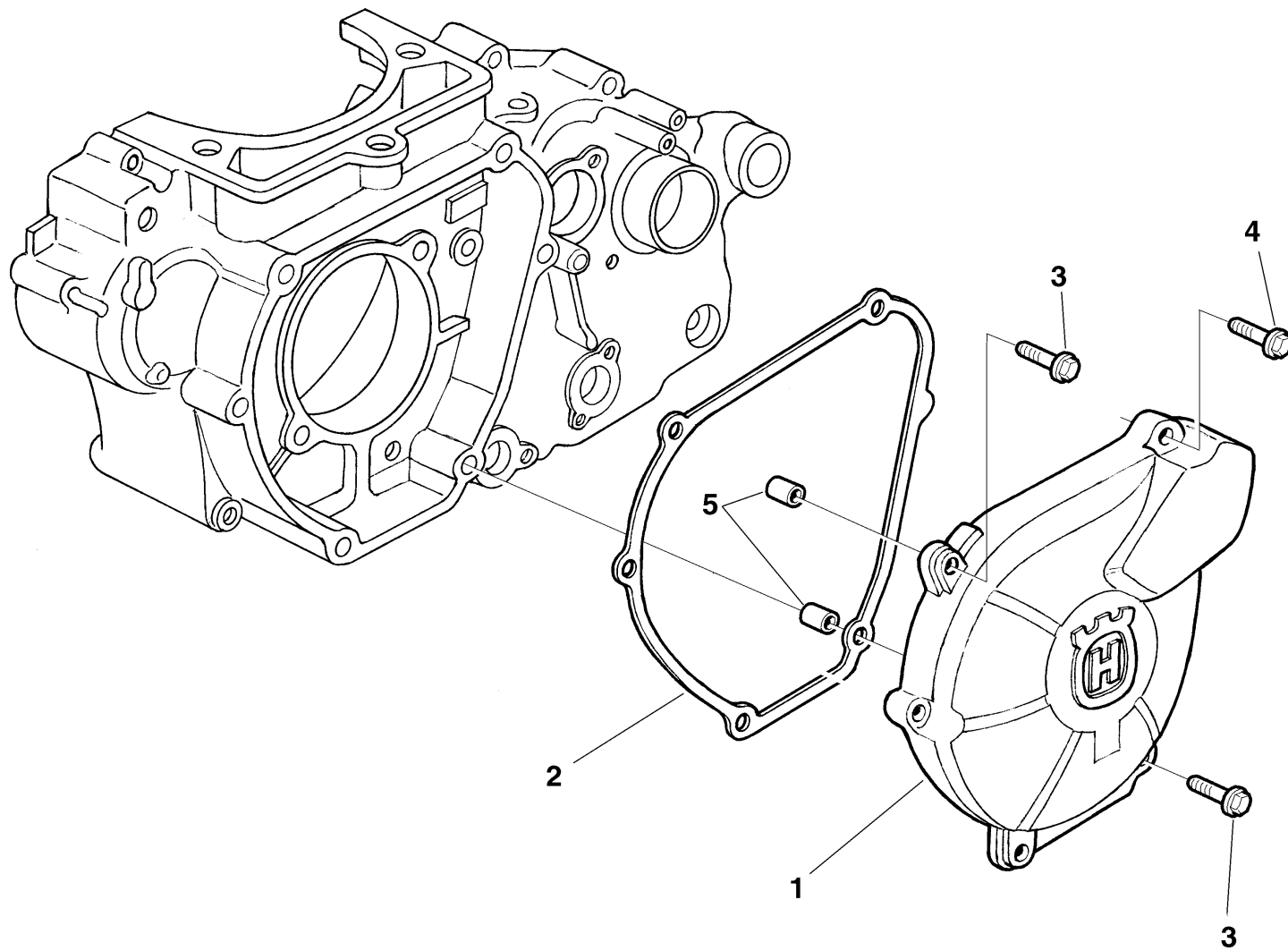

Note Notes Marke Notas	Pos. No. N. Index Pos.	N. Cod. Code No. Nr. Code Code Nr N. Cod.	Q.tà Q.ty Q.te M.ge C.ad	DENOMINAZIONE	NAME	DESIGNATION	BESCHREIBUNG	DENOMINACION	Validità Validity Validité Gültig Validez
	1	80A0 99174	1	Coperchio accensione (TC 450-510, TE , SMR)	Ignition cover (TC 450-510, TE , SMR)	Couvercle allumage (TC 450-510, TE , SMR)	Zündungdeckel (TC 450-510, TE , SMR)	Tapa encendido (TC 450-510, TE , SMR)	
	1	80A0 A1054	1	Coperchio accensione (TC 250)	Ignition cover (TC 250)	Couvercle allumage (TC 250)	Zündungdeckel (TC 250)	Tapa encendido (TC 250)	
	2	8000 99856	1	Guarnizione	Gasket	Garnitue	Dichtung	Junta	
	3	8A00 67545	2	Vite (M6X35 mm)	Screw (M6X35 mm)	Vis (M6X35 mm)	Schraube (M6X35 mm)	Tornillo (M6X35 mm)	
	4	8000 62729	4	Vite (M6X25 mm)	Screw (M6X25 mm)	Vis (M6X25 mm)	Schraube (M6X25 mm)	Tornillo (M6X25 mm)	
	5	8000 07719	2	Bussola	Bushing	Douille	Buchse	Manguito	

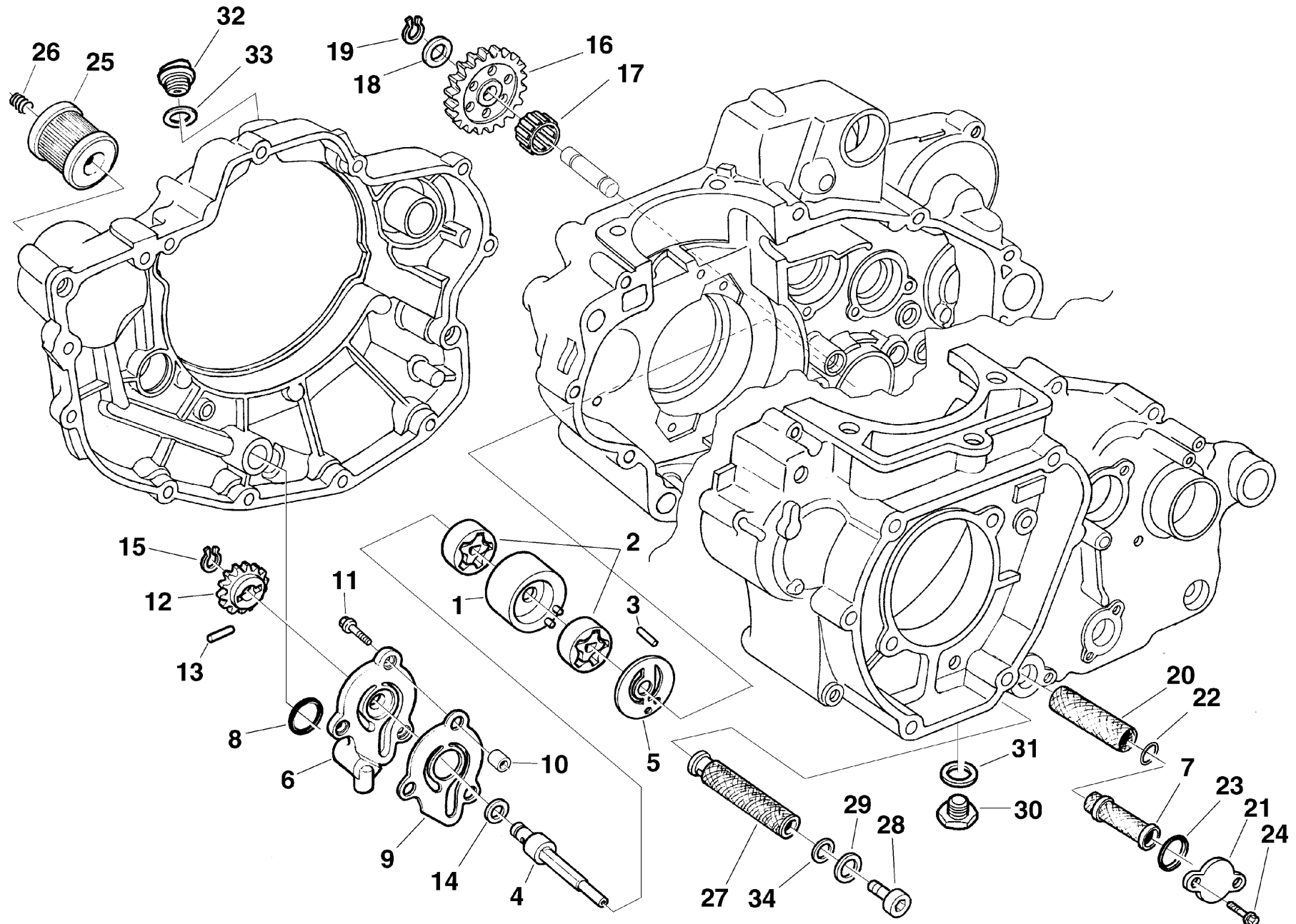

Note Notes Marke Notas	Pos. No. N. Index Pos.	N. Cod. Code No. Nr. Code Code Nr N. Cod.	Q.tà Q.ty Q.te M.ge C.ad	DENOMINAZIONE	NAME	DESIGNATION	BESHREIBUNG	DENOMINACION	Validità Validity Validité Gültig Validez
	1	8000 99858	1	Corpo porta rotori	Pump body	Corps pompe	Pumpenkörper	Corpo bomba	
	2	8000 82948	2	Rotore recupero olio	Rotor assy.	Rotor compl.	Rotor kpl.	Rotor compl.	
	3	8A00 47773	2	Rullino	Roller	Aiguille	Rolle	Rodillo	
	4	8000 99860	1	Albero pompa lubrificazione	Pump shaft	Arbre pompe	Pumpenwelle	Eje bomba	
	5	8000 99861	1	Distanziale	Spacer	Entretoise	Distanzstück	Separador	
	6	8000 91552	1	Coperchio pompa lubrificazione	Pump cover	Couvercle pompe	Pumpendeckel	Tapa bomba	
	7	8000 72427	1	Filtro a rete interno	Inner filter	Filtre	Filter	Filtro	
	8	8000 25082	1	Anello OR	O-Ring	Bague OR	O-Ring	Anillo OR	
	9	8000 99862	1	Coperchio intermedio	Pump cover	Couvercle pompe	Pumpendeckel	Tapa bomba	
	10	1617 95502	2	Bussola	Bushing	Douille	Buchse	Manguito	
	11	8000 62728	3	Vite (M6X20 mm)	Screw (M6X20 mm)	Vis (M6X20 mm)	Schraube (M6X20 mm)	Tornillo (M6X20 mm)	
	12	8000 99863	1	Ingranaggio condotto (Z=11)	Gear (Z=11)	Engranaage (Z=11)	Zahnrad (Z=11)	Engranaje (Z=11)	
	13	8000 47773	1	Rullino	Roller	Aiguille	Rolle	Rodillo	
	14	8E00 34292	1	Rosetta	Washer	Rondelle	Scheibe	Arandela	
	15	8000 21375	1	Anello di fermo	Stop ring	Bague d'arrêt	Haltering	Anillo de retención	
	16	8000 99864	1	Ingranaggio intermedio (Z=24)	Gear (Z=24)	Engranaage(Z=24)	Zahnrad (Z=24)	Engranaje (Z=24)	
	17	8000 33718	1	Cuscinetto a rullini (ø12xø16x10 mm)	Needle bearing (ø12xø16x10 mm)	Roulement à aiguilles (ø12xø16x10 mm)	Nadelkäfig (ø12xø16x10 mm)	Cojinete de rodillos (ø12xø16x10 mm)	
	18	8A00 01261	1	Rosetta D19-d12	Washer D19-d12	Rondelle D19-d12	Scheibe D19-d12	Arandela D19-d12	
	19	66N0 21202	1	Anello di fermo	Stop ring	Bague d'arrêt	Haltering	Anillo de retención	
	20	8000 72426	1	Filtro a rete esterno	Outer filter	Filtre	Filter	Filtro	
	21	8000 72425	1	Coperchio	Cover	Couvercle	Deckel	Tapa	
	22	8000 26884	1	Anello OR	O-Ring	Bague OR	O-Ring	Anillo OR	
	23	8000 34609	1	Anello OR	O-Ring	Bague OR	O-Ring	Anillo OR	
	24	8000 66525	2	Vite	Screw	Vis	Schraube	Tornillo	
	25	8000 81675	1	Filtro a cartuccia	Cartridge filter	Filtre	Filter	Filtro	
	26	8000 99866	1	Molla	Spring	Ressort	Feder	Resorte	
	27	8A00 74716	1	Filtro a rete	Filter	Filtre	Filter	Filtro	
	28	8000 99711	1	Tappo	Plug	Bouchon	Verschluss	Tapòn	
	29	62N0 15678	1	Rosetta	Washer	Rondelle	Scheibe	Arandela	
	30	8000 73011	1	Tappo scarico olio	Oil drain plug	Bouchon	Verschluss	Tapòn	
	31	62N0 15679	1	Rosetta	Washer	Rondelle	Scheibe	Arandela	
	32	8000 36786	1	Tappo carico olio	Oil filler cap	Bouchon	Verschluss	Tapòn	

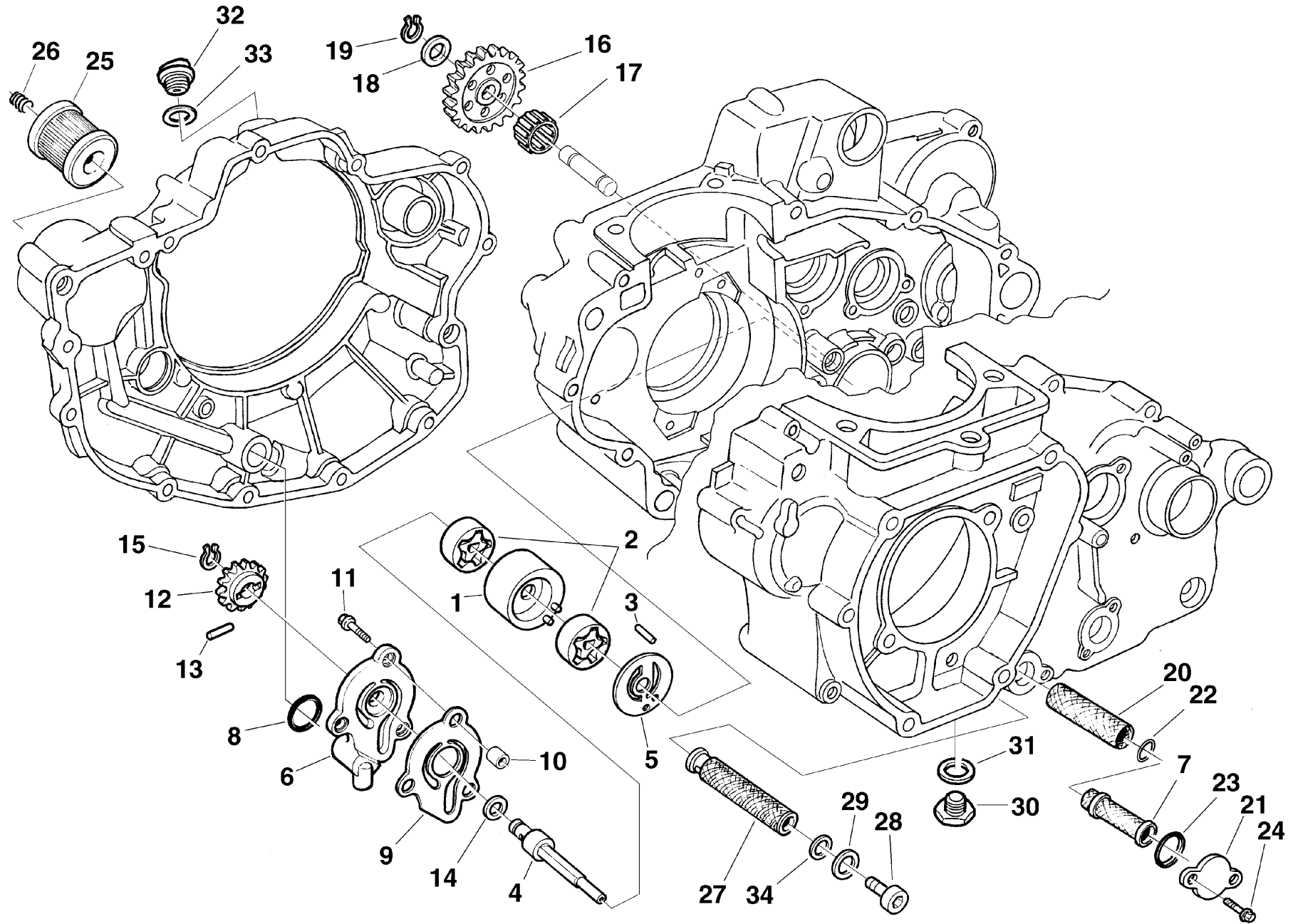





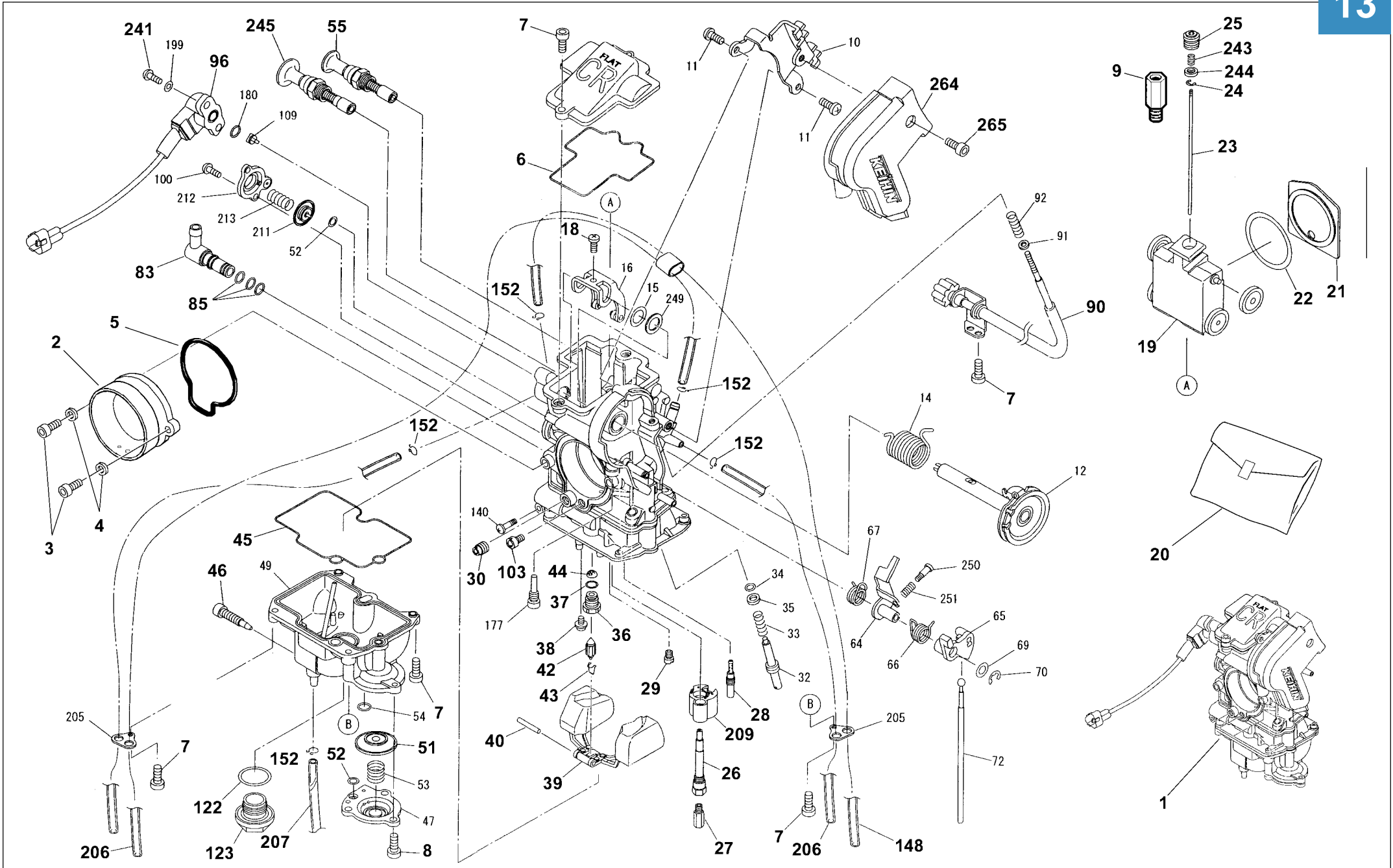

Note Notes Marke Notas	Pos. No. N. Index Pos.	N. Cod. Code No. Nr. Code Code Nr N. Cod.	Q.tà Q.ty Q.te M.ge C.ad	DENOMINAZIONE	NAME	DESIGNATION	BESHREIBUNG	DENOMINACION	Validità Validity Validité Gültig Validez
<b>C</b>	1	8000 A4143	1	Carburatore 37 (250)	Carburetor 37 (250)	Carburateur 37 (250)	Vegaser 37 (250)	Carburador 37 (250)	
<b>WM</b>	1	8000 A5741	1	Carburatore 37 (250)	Carburetor 37 (250)	Carburateur 37 (250)	Vegaser 37 (250)	Carburador 37 (250)	
<b>C</b>	1	8000 A4144	1	Carburatore 41 (450)	Carburetor 41 (450)	Carburateur 41 (450)	Vegaser 41 (450)	Carburador 41 (450)	
<b>WM</b>	1	8000 A5740	1	Carburatore 41 (450-510)	Carburetor 41 (450-510)	Carburateur 41 (450-510)	Vegaser 41 (450-510)	Carburador 41 (450-510)	
<b>C</b>	1	8000 A4146	1	Carburatore 41 (510)	Carburetor 41 (510)	Carburateur 41 (510)	Vegaser 41 (510)	Carburador 41 (510)	
	2	8000 A2987	1	Cornetto presa aria	Pipe	Manchon	Muffe	Tubo toma aire	
	3	60N1 02482	2	Vite	Screw	Vis	Schraube	Tornillo	
	4	8000 36137	2	Rosetta	Washer	Rondelle	Scheibe	Arandela	
	5	8000 98215	1	Anello OR	O-Ring	Anneau OR	O-Ring	Bague OR	
	6	8000 A5616	1	Anello OR	O-Ring	Anneau OR	O-Ring	Bague OR	
	7	8A00 A5617	6	Vite	Screw	Vis	Schraube	Tornillo	
	8	8000 A5617	3	Vite	Screw	Vis	Schraube	Tornillo	
<b>WM</b>	9	8000 A6468	1	Distanziale	Spacer	Entretoise	Dstanzstück	Separador	
	18	8000 A5618	1	Vite	Screw	Vis	Schraube	Tornillo	
	19	8000 A5619	1	Valvola gas 15/M	Throttle valve 15/M	Papillon de gaz 15/M	Drosselklappe 15/M	Válvula 15/M	
<b>D</b>	20	8000 A6115	1	Kit carburatore (TE 250)	Carburetor kit (TE 250)	Kit carburateur (TE 250)	Vergaser Kit (TE 250)	Kit carburador (TE 250)	
<b>D</b>	20	8000 A4295	1	Kit carburatore (TC 250)	Carburetor kit (TC 250)	Kit carburateur (TC 250)	Vergaser Kit (TC 250)	Kit carburador (TC 250)	
<b>D</b>	20	8000 A5918	1	Kit carburatore	Carburetor kit (450-510)	Kit carburateur (450-510)	Vergaser Kit (450-510)	Kit carburador (450-510)	
				(TE-SM 450-510)	(TE-SM 450-510)	(TE-SM 450-510)	(TE-SM 450-510)	(TE-SM 450-510)	
<b>D</b>	20	8000 A4296	1	Kit carburatore (TC 450-510)	Carburetor kit (TC 450-510)	Kit carburateur (TC 450-510)	Vergaser Kit (TC 450-510)	Kit carburador (TC 450-510)	
	21	8000 A5620	1	Sede guarnizione	Floating valve	Siège garniture	Dichtung Sitzring	Alojamento junta	
	22	8000 A5621	1	Guarnizione	Seal	Garniture	Dichtung	Junta	
<b>WM</b>	23	8C00 98196	1	Spillo conico OBDVT	Needle OBDVT	Pointeau conique OBDVT	Kon. Nadel OBDVT	Pasador cónico OBDVT	
<b>C</b>	23	8000 98196	1	Spillo conico OBDVR	Needle OBDVR	Pointeau conique OBDVR	Kon. Nadel OBDVR	Pasador cónico OBDVR	
	24	8000 A5622	1	Anello seeger	Clip	Anneau seeger	SEEGER Ring	Anillo SEEGER	
	25	8000 A5623	1	Vite per spillo	Needle set screw	Vis pour pointeau conique	Kon. Nadel Schraube	Tornillo por pasador cónico	
	26	8000 A5624	1	Polverizzatore P4	Main nozzle P4	Pulvérisateur P4	Einspritzdüse P4	Pulverizador P4	
	27	8D00 98186	1	Getto massimo 175 (250)	Main jet 175 (250)	Gicleur principal 175 (250)	Hauptdüse 175 (250)	Chiclé máximo 175 (250)	
	27	8A00 98186	1	Getto massimo 180	Main jet 180	Gicleur principal 180	Hauptdüse 180	Chiclé máximo 180	
				(450, TE-SM 510)	(450, TE-SM 510)	(450, TE-SM 510)	(450, TE-SM 510)	(450, TE-SM 510)	
	27	8000 98186	1	Getto massimo 185 (TC 510)	Main jet 185 (TC 510)	Gicleur principal 185 (TC 510)	Hauptdüse 185 (TC 510)	Chiclé máximo 185 (TC 510)	
	28	8D00 A4624	1	Getto minimo (50)	Idle jet (50)	Gicleur minimum (50)	Leerlaufdüse (50)	Chiclé mínimo (50)	
				(250, TE-SM)	(250, TE-SM)	(250, TE-SM)	(250, TE-SM)	(250, TE-SM)	

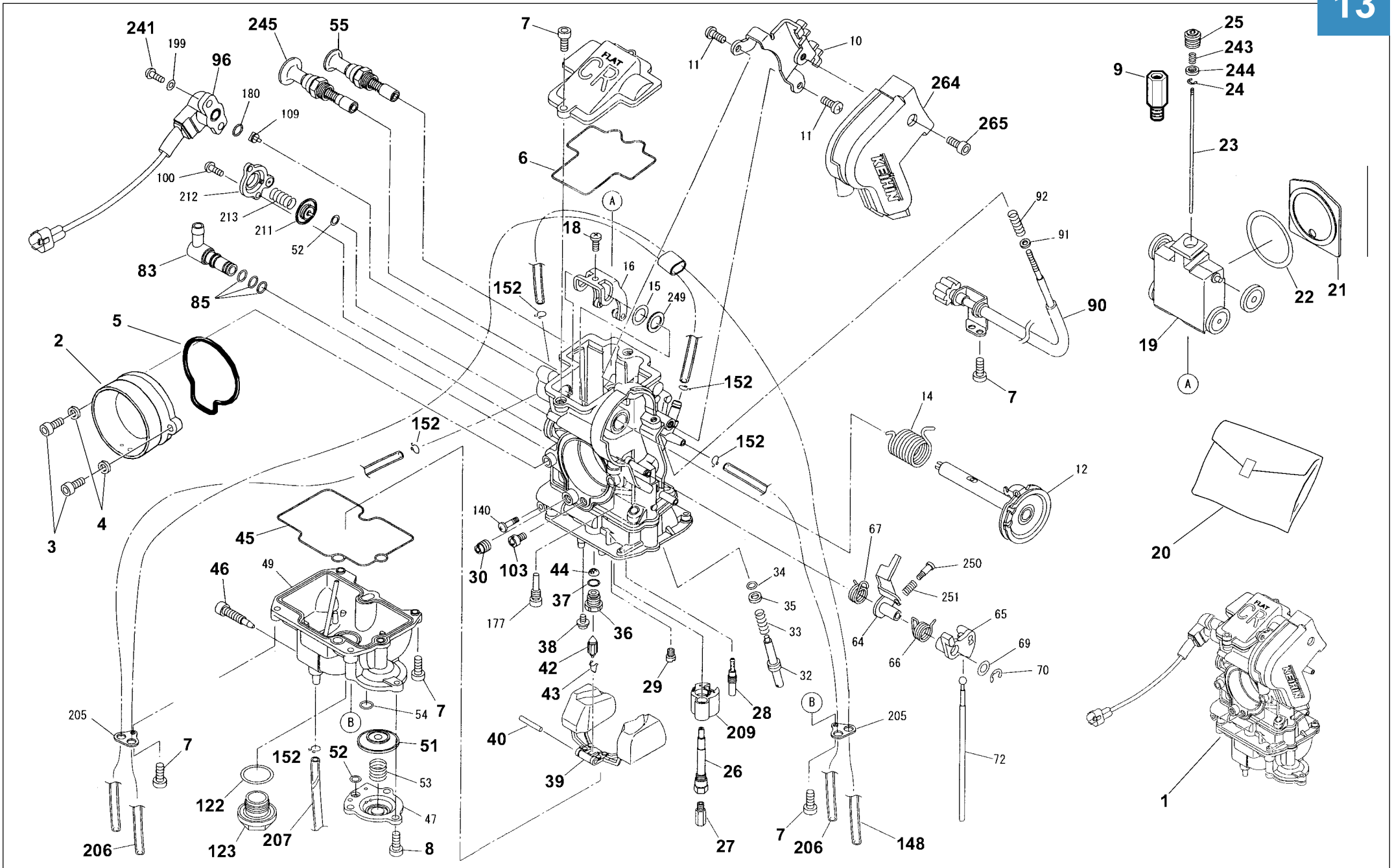

Note Notes Notas	Pos. No. N. Index Pos.	N. Cod. Code No. Nr. Code Code Nr N. Cod.	Q.tà Q.ty Q.te M.ge C.ad	DENOMINAZIONE	NAME	DESIGNATION	BESHREIBUNG	DENOMINACION	Validità Validity Validité Gültig Validez
	28	8F00 A4624	1	Getto minimo (55) (TC 450-510)	Idle jet (55) (TC 450-510)	Gicleur minimum (55) (TC 450-510)	Leerlaufdüse (55) (TC 450-510)	Chiclé mínimo (55) (TC 450-510)	
	29	8A00 98275	1	Getto starter (72) (250, TC 450)	Starter jet (72) (250, TC 450)	gicleur starter (72) (250, TC 450)	Starterdüse (72) (250, TC 450)	chiclé starter (72) (250, TC 450)	
	29	8000 98275	1	Getto starter (85) (TE-SM 450, 510)	Starter jet (85) (TE-SM 450, 510)	gicleur starter 85 (TE-SM 450, 510)	Starterdüse (85) (TE-SM 450, 510)	chiclé starter (85) (TE-SM 450, 510)	
	30	8000 98268	1	Getto aria minimo 100	Slow air jet 100	Gicleur d'air de ralenti 100	Leerlaufdüse 100	Surtidor aire minimo 100	
	36	8000 98272	1	Sede valvola	Valve seat	Siège soupape	Drosselsitz	Alojamento válvula	
	37	8000 A5625	1	Anello OR	O-Ring	Anneau OR	O-Ring	Anillo OR	
	38	8000 A5626	1	Vite	Screw	Vis	Schraube	Tornillo	
	39	8000 A5627	1	Galleggiante	Float comp.	Flotteur	Schwimmer	Flotador	
	40	8000 A5628	1	Perno	Arm pin	Pivot	Bolzen	Perno	
	42	8000 A5629	1	Valvola a spillo	Float valve comp.	Soupape à pointeau	Nadelventil	Válvula de aguja	
	43	8000 A5630	1	Molla per valvola a spillo	Needle valve clip	Ressort	Feder	Resorte	
	44	8000 A5631	1	Filtro	Fuel strainer comp.	Filtre	Filter	Filtro	
	45	8000 A5632	1	Anello OR	O-Ring	Anneau OR	O-Ring	Bague OR	
	46	8000 A5633	1	Vite di spurgo	Drain screw	Vidange	Entleerung	Purga	
	51	8000 A5634	1	Diaframma (250)	Diaphragm comp. (250)	Diaphragme (250)	Biegeplatte (250)	Diafragma (250)	
	51	8A00 A5634	1	Diaframma (450-510)	Diaphragm comp. (450-510)	Diaphragme (450-510)	Biegeplatte (450-510)	Diafragma (450-510)	
	52	8000 A5635	1	Anello OR	O-Ring	Anneau OR	O-Ring	Anillo OR	
	55	8000 A5636	1	Kit starter (freddo)	Starter valve comp. (cold)	Kit démarrage (froid)	Starter kit (Kälte)	Kit arranque (frio)	
	83	8000 A5637	1	Raccordo Sx	L joint comp.	Raccord	Anschluss	Empalme	
	85	8000 A5638	1	Anello OR	O-Ring	Anneau OR	O-Ring	Bague OR	
	90	8000 A5639	1	Vite regolazione minimo	Stop screw idle speed adj.	Fil de reglage	Reglerkabel	Trans. de regulacion	
	96	8000 A5640	1	Sensore valvola gas	Throttle sensor	Sensor papillon de gaz	Drosselklappensensor	Sensòr válvula	
	103	8000 98250	1	Getto aria massimo 200	Main air jet 200	Gicleur d'air principal 200	Hauptluftdüse 200	Surtidor aire máximo 200	
	122	8000 A5641	1	Anello OR	O-Ring	Anneau OR	O-Ring	Bague OR	
	123	8000 A5642	1	Tappo vaschetta	Cap drain	Bouchon	Verschluss	Tapón	
	148	8000 A5643	1	Tubo	Vinyl pipe, bowl vent	Tuyau	Rohr	Tubo	
	152	8000 A5644	1	Molletta	Tube clip	Ressort	Feder	Resorte	
	206	8000 A5645	2	Tubo	Vinyl pipe, bowl vent	Tuyau	Rohr	Tubo	
	207	8000 A5646	1	Tubo	Vinyl pipe, bowl vent	Tuyau	Rohr	Tubo	
	209	8000 A5647	1	Porta getto	Buffer plate	Porte gicleur	Düsenträger	Portachiclé	

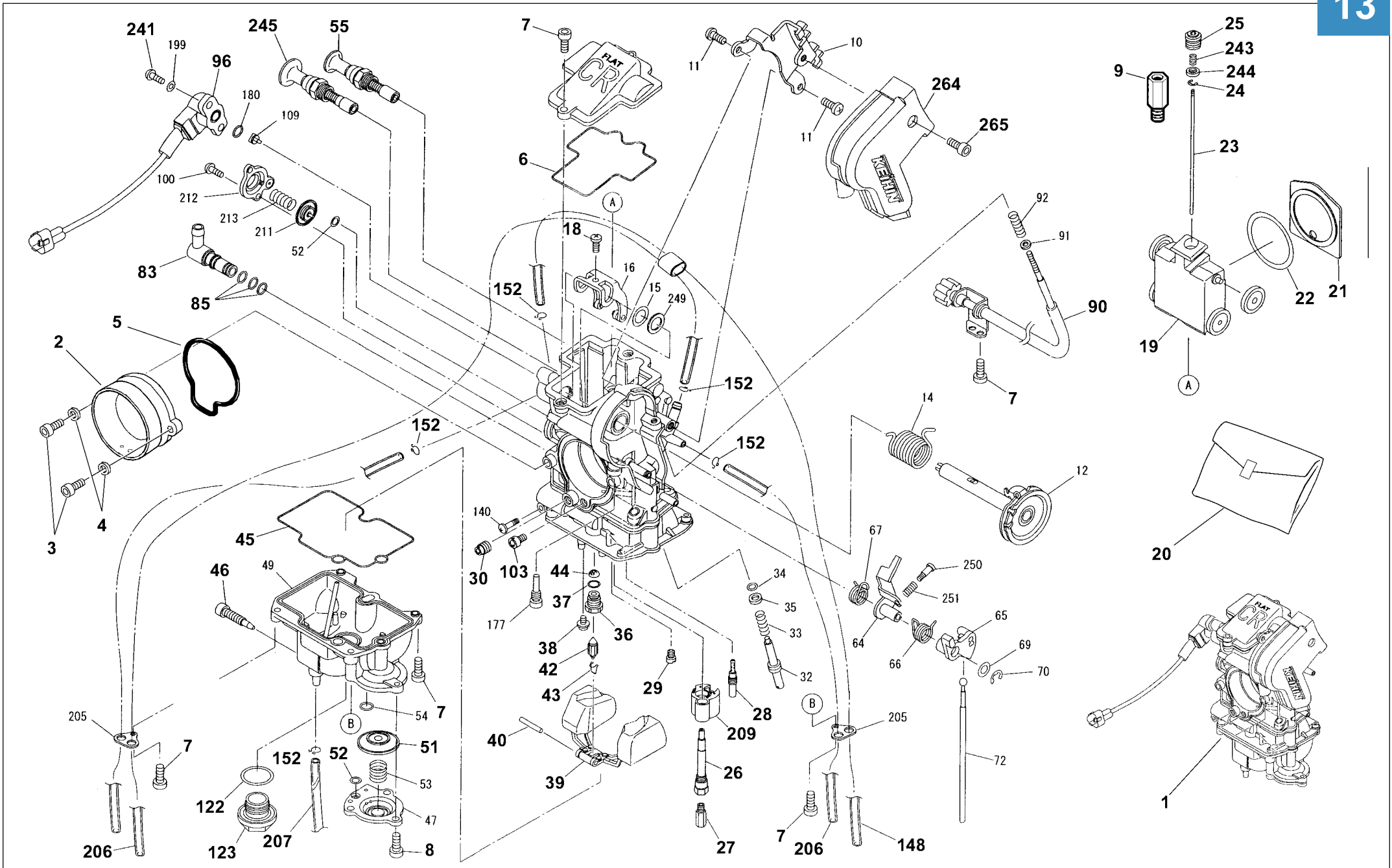





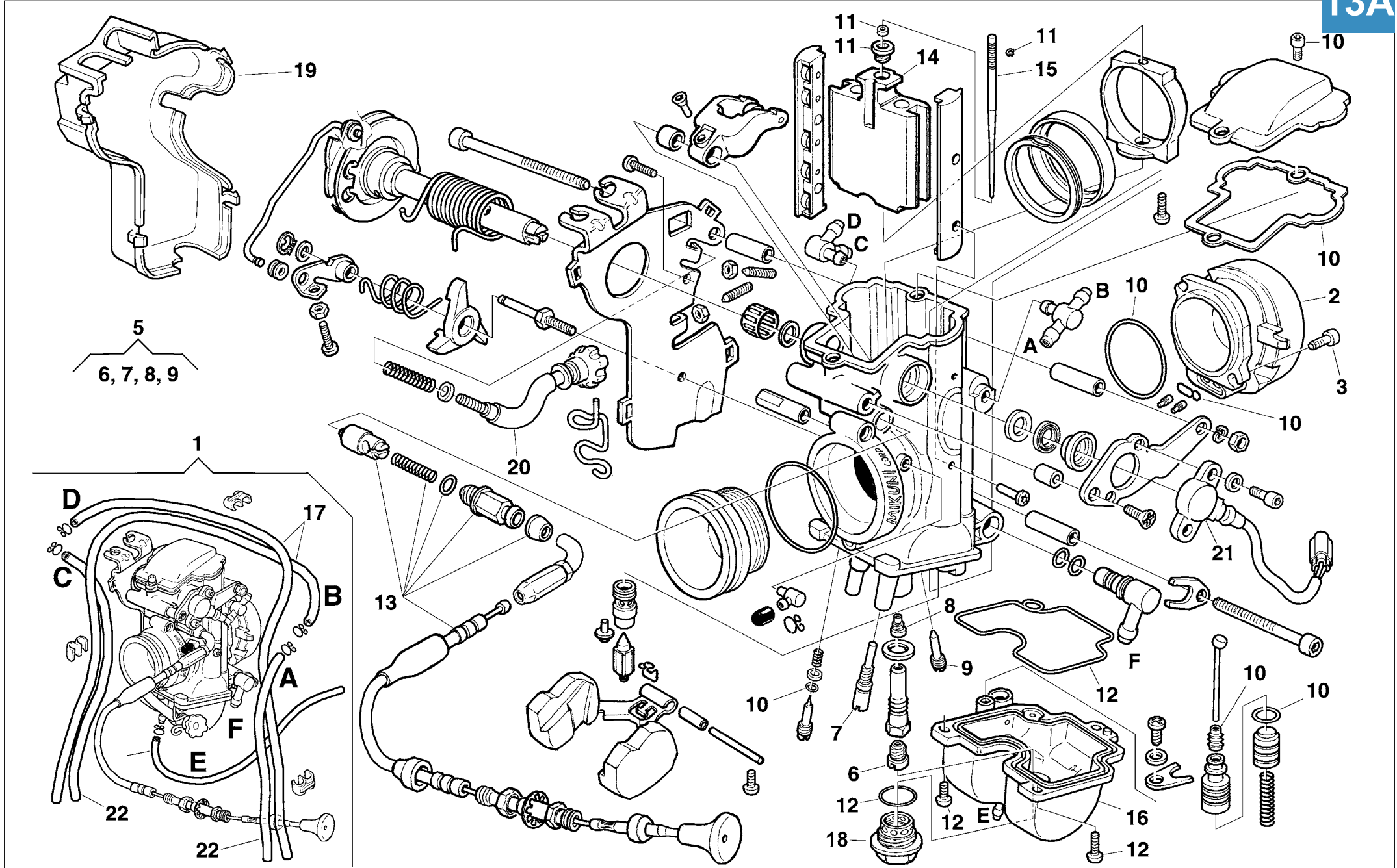

Note Notes Notes Marka Notas	Pos. No. N. Index Pos.	N. Cod. Code No. Nr. Code Code Nr N. Cod.	Q.tà Q.ty Q.te M.ge C.ad	DENOMINAZIONE	NAME	DESIGNATION	BESHREIBUNG	DENOMINACION	Validità Validity Validité Gültig Validez
	1	8000 A3084	1	Carburatore TMR 38	Carburetor TMR 38	Carburateur TMR 38	Vegaser TMR 38	Carburador TMR 38	
	2	8000 A0917	1	Cornetto presa aria	Pipe	Manchon	Muffe	Tubo toma aire	
	3	60N3 02463	2	Vite	Screw	Vis	Schraube	Tornillo	
	5	8000 A3091	1	Kit carburat. TMR 38	Carburetor kit TMR 38	Kit carburateur TMR 38	Vergaser Kit TMR 38	Kit carburador TMR 38	
<b>S</b>	6	8D00 80171	1	Getto massimo (165)	Main jet (165)	Gicleur principal (165)	Hauptdüse (165)	Chiclé máximo (165)	
<b>¥</b>	6	8C00 80171	1	Getto massimo (160)	Main jet (160)	Gicleur principal (160)	Hauptdüse (160)	Chiclé máximo (160)	
<b>¥</b>	6	8A00 80171	1	Getto massimo (162,5)	Main jet (162,5)	Gicleur principal (162,5)	Hauptdüse (162,5)	Chiclé máximo (162,5)	
<b>¥</b>	6	8E00 80171	1	Getto massimo (167,5)	Main jet (167,5)	Gicleur principal (167,5)	Hauptdüse (167,5)	Chiclé máximo (167,5)	
<b>¥</b>	6	8T00 80171	1	Getto massimo (170)	Main jet (170)	Gicleur principal (170)	Hauptdüse (170)	Chiclé máximo (170)	
<b>S</b>	7	8H00 A1804	1	Getto minimo (25)	Idle jet (25)	Gicleur minimum (25)	Leerlaufdüse (25)	Chiclé mínimo (25)	
<b>¥</b>	7	8K00 A1804	1	Getto minimo (22,5)	Idle jet (22,5)	Gicleur minimum (22,5)	Leerlaufdüse (22,5)	Chiclé mínimo (22,5)	
<b>¥</b>	7	8G00 A1804	1	Getto minimo (27,5)	Idle jet (27,5)	Gicleur minimum (27,5)	Leerlaufdüse (27,5)	Chiclé mínimo (27,5)	
<b>S</b>	8	8000 A1806	1	Polverizzatore (P4)	Fuel nozzle (P4)	Pulvérisateur (P4)	Einspritzdüse (P4)	Pulverizador (P4)	
<b>¥</b>	8	8A00 A1806	1	Polverizzatore (P3)	Fuel nozzle (P3)	Pulvérisateur (P3)	Einspritzdüse (P3)	Pulverizador (P3)	
<b>¥</b>	8	8B00 A1806	1	Polverizzatore (P5)	Fuel nozzle (P5)	Pulvérisateur (P5)	Einspritzdüse (P5)	Pulverizador (P5)	
<b>S</b>	9	8000 A1809	1	Getto pompa (30)	Pump jet (30)	Gicleur pompe (30)	Pumpendüse (30)	Chiclé bomba (30)	
<b>¥</b>	9	8A00 A1809	1	Getto pompa (35)	Pump jet (35)	Gicleur pompe (35)	Pumpendüse (35)	Chiclé bomba (35)	
	10	8000 A1794	1	Kit O Ring - viti	O Ring - Screw kit	Kit O Rings - Vis	O Rings - Schrauben Kit	Kit O Rings - Tornillos	
	11	8000 A1796	1	Kit getto- Polverizzatore	Jet-Fuel nozzle kit	Kit Gicleur - Pulvérisateur	Düse- Einspritzdüse Kit	Kit Chiclé - Pulverizador	
	12	8000 A1795	1	Kit O Ring - viti	O Rings - Screws kit	Kit O Rings - Vis	O Rings - Schrauben Kit	Kit O Rings - Tornillos	
	13	8000 A1797	1	Kit STARTER	STARTER kit	Kit DEMARRAGE	STARTER kit	Kit ARRANQUE	
	14	8A00 A1807	1	Valvola gas (1.0)	Throttle valve (1.0)	Papillon de gaz (1.0)	Drosselklappe (1.0)	Válvula (1.0)	
	15	8000 A1808	1	Spillo conico (52)	Needle (52)	Pointeau conique (52)	Kon. Nadel (52)	Pasador cónico (52)	
	16	8000 A1801	1	Vaschetta completa	Chamber assy.	Cuvette compl.	Becken kpl	Cubeta compl.	
	17	8000 A1800	2	Tubazione (L=750 mm)	Pipe (L=750 mm)	Tuyau (L=750 mm)	Rohr (L=750 mm)	Tubo (L=750 mm)	
	18	8000 A1803	1	Tappo	Plug	Bouchon	Verschluss	Tapón	
	19	8000 A1798	1	Coperchio	Cover	Couvercle	Deckel	Tapa	
	20	8000 A1799	1	Cavo regolazione	Adjusting cable	Fil de reglage	Reglerkabel	Trans. de regulacion	
	21	8000 A1802	1	Sensore	Sensor	Sensor	Sensor	Sensór	
	22	8A00 A1800	2	Tubazione (L=550 mm)	Pipe (L=550 mm)	Tuyau (L=550 mm)	Rohr (L=550 mm)	Tubo (L=550 mm)	
<b>¥</b>				FORNITO NEL KIT 8000 A3091	SUPPLIED IN BAG 8000 A3091	SON FOURNIES EN UNITES 8000 A3091	SIND IM UMSCHLAG BEZ 8000 A3091	PROVISTO EN GRUPO 8000 A3091	

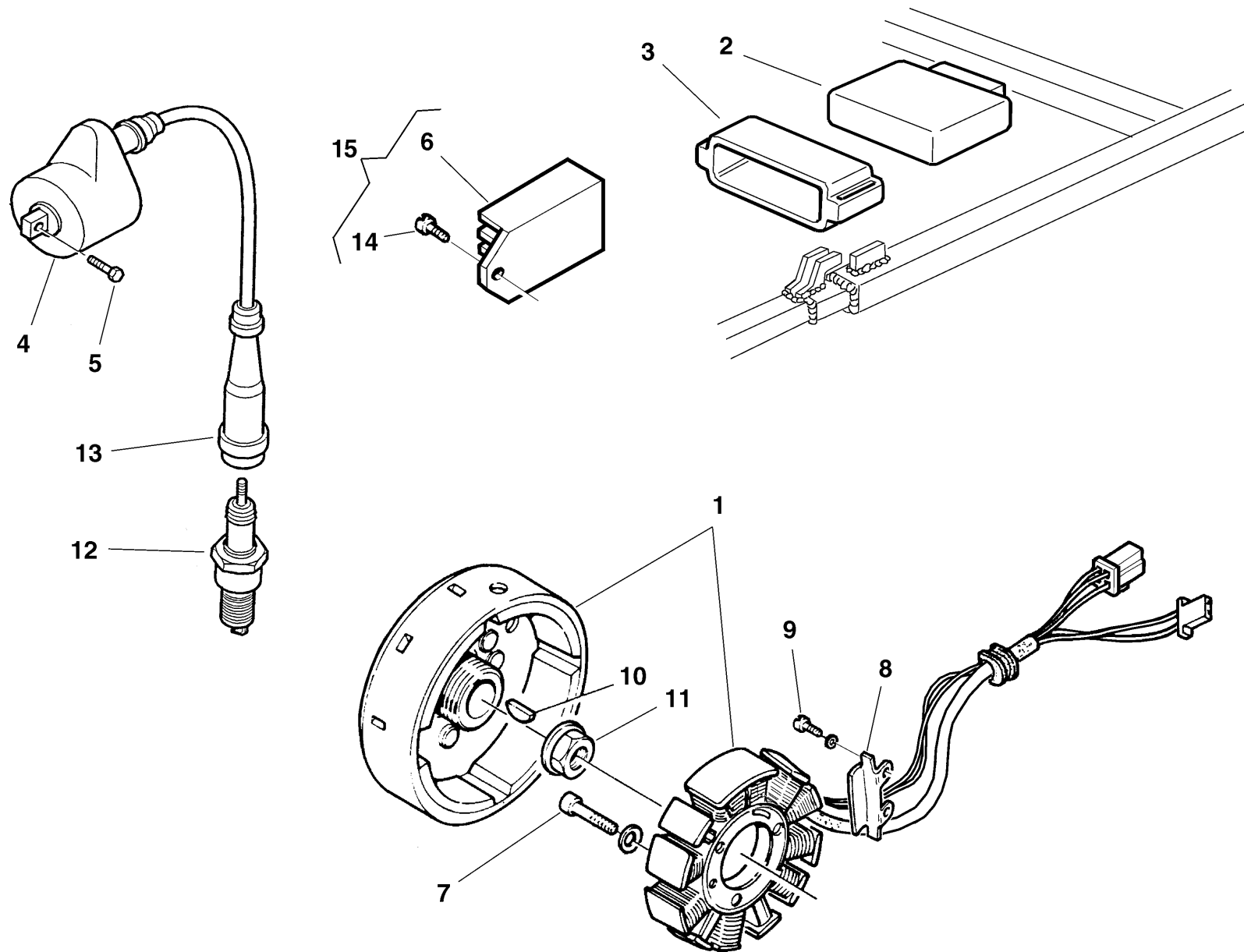

Note Notes Notas	Pos. No. N. Index Pos.	N. Cod. Code No. Nr. Code Code Nr N. Cod.	Q.tà Q.ty Q.te M.ge C.ad	DENOMINAZIONE	NAME	DESIGNATION	BESHREIBUNG	DENOMINACION	Validità Validity Validité Gültig Validez
	1	8000 A4245	1	Alternatore compl. (TE 250)	Alternator compl. (TE 250)	Alternateur compl. (TE 250)	Lichtmaschine kpl. (TE 250)	Alternador compl. (TE 250)	
	1	8000 A4266	1	Alternatore compl. (TC 250)	Alternator compl. (TC 250)	Alternateur compl. (TC 250)	Lichtmaschine kpl. (TC 250)	Alternador compl. (TC 250)	
	1	8000 91977	1	Alternatore completo (400)	Alternator compl. (400)	Alternateur compl.. (400)	Lichtmaschine kpl. (400)	Alternador compl. (400)	
	1	8000 A4257	1	Alternatore completo (TE 450-510)	Alternator compl. (TE 450-510)	Alternateur compl. (TE 450-510)	Lichtmaschine kpl. (TE 450-510)	Alternador compl. (TE 450-510)	
	1	8000 A4265	1	Alternatore completo (TC-SMR 450, 510)	Alternator compl. (TC-SMR 450, 510)	Alternateur compl.. (TC-SMR 450, 510)	Lichtmaschine kpl. (TC-SMR 450, 510)	Alternador compl. (TC-SMR 450, 510)	
	2	8000 A4044	1	Centralina elettronica (250)	Electronic device (250)	Dispositif électronique (250)	Zündelectronic (250)	Centralita electrónica (250)	
	2	8A00 91975	1	Centralina elettronica (400)	Electronic device (400)	Dispositif électronique (400)	Zündelectronic (400)	Centralita electrónica (400)	
	2	8000 A4052	1	Centralina elettronica (450-510)	Electronic device (450-510)	Dispositif électronique (450-510)	Zündelectronic (450-510)	Centralita electrónica (450-510)	
	3	8000 A4045	1	Supporto elastico (250-450-510)	Elastic holder (250-450-510)	Support (250-450-510)	Halterung (250-450-510)	Soporte (250-450-510)	
	3	8000 91984	1	Supporto elastico (400)	Elastic holder (400)	Support (400)	Halterung (400)	Soporte (400)	
	4	8000 91976	1	Bobina	Coil	Bobine	Zündspule	Bobina	
	5	8000 62727	2	Vite	Screw	Vis	Schraube	Tornillo	
	6	8000 91978	1	Regolatore di tensione (TC 450-510, TE, SMR)	Voltage regulator (TC 450-510, TE, SMR)	Régulateur de tension (TC 450-510, TE, SMR)	Spannungsregler (TC 450-510, TE, SMR)	Regulador de tensión (TC 450-510, TE, SMR)	
	6	8000 A1431	1	Regolatore di tensione (TC 250)	Voltage regulator (TC 250)	Régulateur de tension (TC 250)	Spannungsregler (TC 250)	Regulador de tensión (TC 250)	
	7	8000 62728	2	Vite (TC 450-510, TE, SMR)	Screw (TC 450-510, TE, SMR)	Vis (TC 450-510, TE, SMR)	Schraube (TC 450-510, TE, SMR)	Tornillo (TC 450-510, TE, SMR)	
	7	60N1 02488	2	Vite (TC 250)	Screw (TC 250)	Vis (TC 250)	Schraube (TC 250)	Tornillo (TC 250)	
	8	8000 99868	1	Piastrina	Plate	Plaquette	Plättchen	Placa	
	9	8A00 67997	2	Vite (TC 450-510, TE, SMR)	Screw (TC 450-510, TE, SMR)	Vis (TC 450-510, TE, SMR)	Schraube (TC 450-510, TE, SMR)	Tornillo (TC 450-510, TE, SMR)	
	9	60N1 02483	2	Vite (TC 250)	Screw (TC 250)	Vis (TC 250)	Schraube (TC 250)	Tornillo (TC 250)	
	10	1513 71301	1	Chiavetta	Woodruff key	Clé woodruff	Federkeil	Lengüeta	
	11	8000 A0033	1	Dado	Nut	Ecrou	Mutter	Tuerca	
	12	8000 A0573	1	Candela NGK	Spark plug	Bougie	Zündkerze	Bujía	
	13	8A00 A0129	1	Cappuccio candela	Cap	Capuchon	Kappe	Capuchón	
<b>WM</b>	14	8000 62727	1	Vite	Screw	Vis	Schraube	Tornillo	

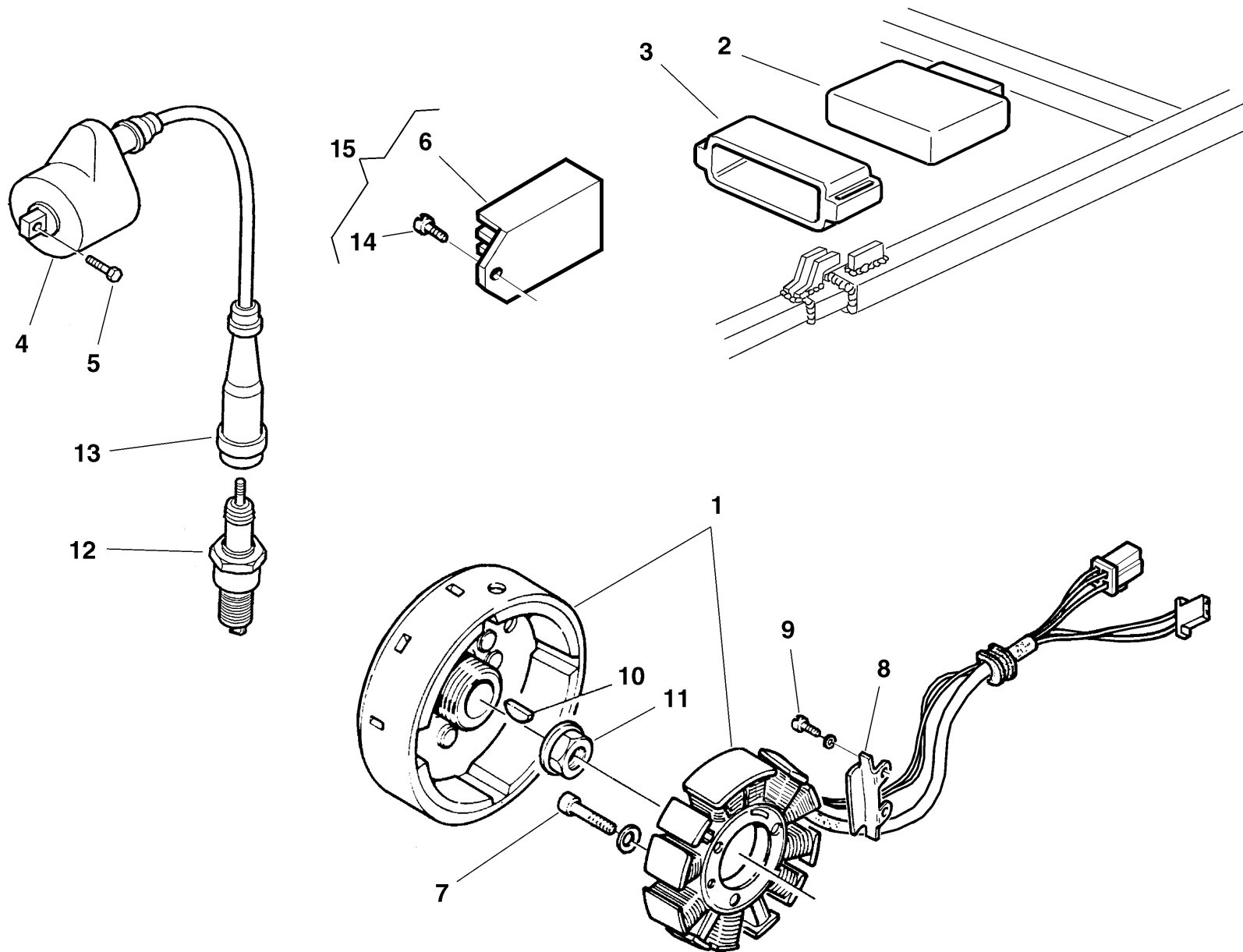



Note Notes Marke Notas	Pos. No. N. Index Pos.	N. Cod. Code No. Nr. Code Code Nr N. Cod.	Q.tà Q.ty Q.te M.ge C.ad	DENOMINAZIONE	NAME	DESIGNATION	BESHREIBUNG	DENOMINACION	Validità Validity Validité Gültig Validez
<b>C</b>	14	8000 62728	2	Vite (TC 250)	Screw (TC 250)	Vis (TC 250)	Schraube (TC 250)	Tornillo (TC 250)	
<b>k</b>	15		1	Kit avviamento elettrico (TC 250)	Electric starting kit (TC 250)	Kit démarrage électronique (TC 250)	Elektronisch Anlasser Kit (TC 250)	Kit arranque electrónico (TC 250)	
<b>K</b>	15		1	Kit avviamento elettrico (TC 450-510)	Electric starting kit (TC 450-510)	Kit démarrage électronique (TC 450-510)	Elektronisch Anlasser Kit (TC 450-510)	Kit arranque electrónico (TC 450-510)	
<b>k</b>				Parte del kit cod. 8000 A6487 Tavola 2 pos. 10	Contained in kit 8000 A6487 drawing 2 no.10	Contenu in kit no. 8000 A6487 table 2 n. 10	Im Kit Code 8000 A6487 Bild 2 Index 10	Contenido en kit 8000 A6487 tabla 2 pos.10	
<b>K</b>				Parte del kit cod. 8000 A6488 Tavola 2 pos. 10	Contained in kit 8000 A6488 drawing 2 no.10	Contenu in kit no. 8000 A6488 table 2 n. 10	Im Kit Code 8000 A6488 Bild 2 Index 10	Contenido en kit 8000 A6488 tabla 2 pos.10	

**TC**

8

1÷5, 7, 9, 11, 12, 27÷33

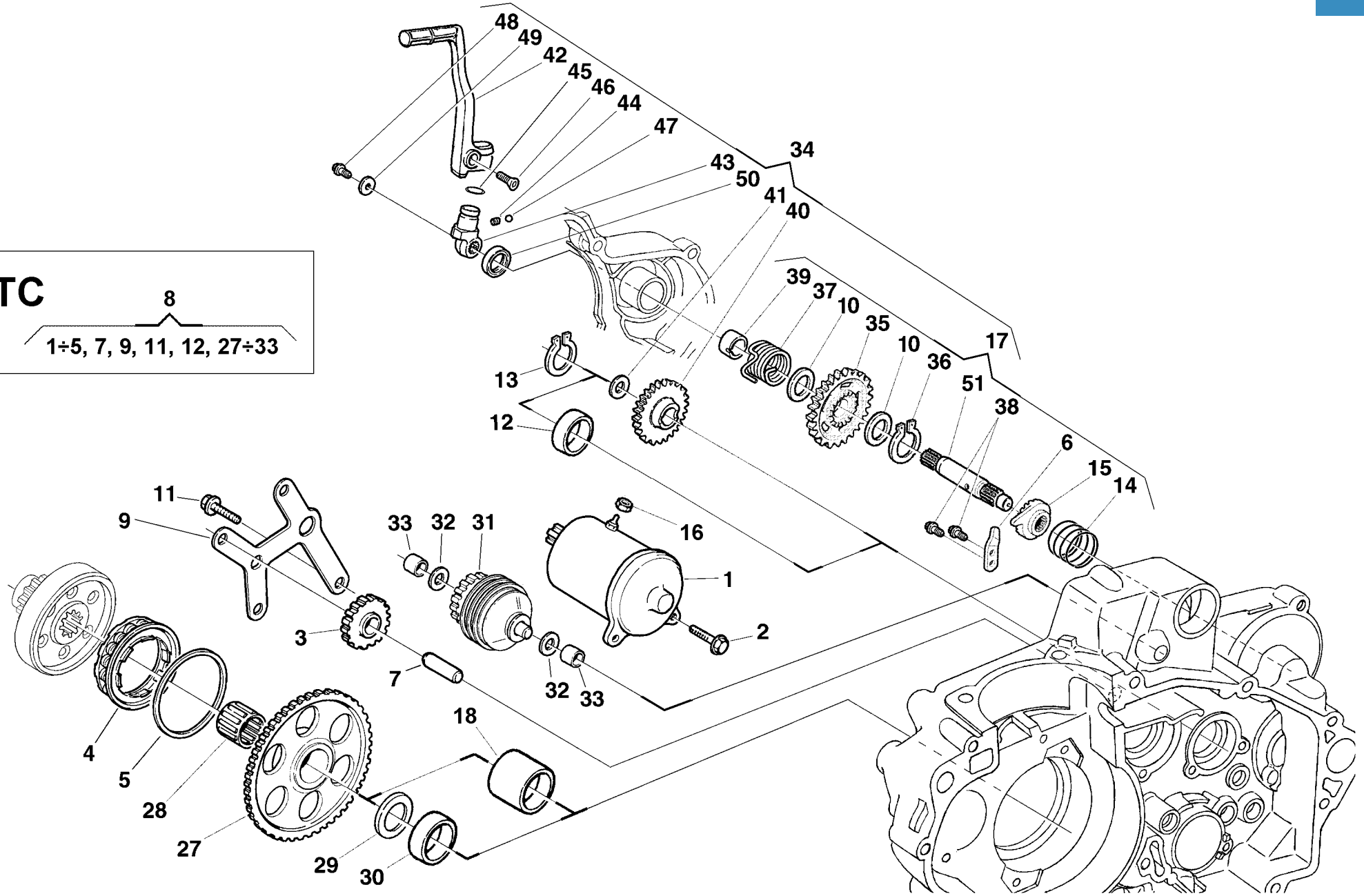

Note Notes Marke Notas	Pos. No. N. Index Pos.	N. Cod. Code No. Nr. Code Code Nr N. Cod.	Q.tà Q.ty Q.te M.ge C.ad	DENOMINAZIONE	NAME	DESIGNATION	BESHREIBUNG	DENOMINACION	Validità Validity Validité Gültig Validez
<b>WM</b>	1	8000 97943	1	Ass. motorino avviamento	El. start motor	Moteur démarr. el.	Elektr Anlasser	Motor de arranque	
<b>WM</b>	2	8000 62729	2	Vite	Screw	Vis	Schraube	Tornillo	
<b>WM</b>	3	8000 99958	1	Ingran. di rinvio (Z =24)	Gear 2nd transmission (Z =24)	Engrenage (Z =24)	Zahnrad (Z =24)	Engrenaje (Z =24)	
<b>W</b>	4	8000 87289	1	Ruota libera (250)	Free wheel (250)	Roue libre (250)	Freilauf (250)	Rueda libre (250)	
<b>WM</b>	4	8000 A0709	1	Ruota libera (400-450-510)	Free wheel (400-450-510)	Roue libre (400-450-510)	Freilauf (400-450-510)	Rueda libre (400-450-510)	
<b>W</b>	5	8000 86732	1	Disco ritegno (250)	Disc (250)	Disque (250)	Scheibe (250)	Disco (250)	
<b>WM</b>	5	8000 A0710	1	Disco ritegno (400-450-510)	Disc (400-450-510)	Disque (400-450-510)	Scheibe (400-450-510)	Disco (400-450-510)	
<b>WC</b>	6	8000 A5890	1	Piastrina	Plate	Plaque	Platte	Placa	
<b>WM</b>	7	8000 99960	1	Perno	Pin	Pivot	Bolzen	Perno	
<b>k</b>	8			Kit avviamento elettrico	Electric starting kit	Kit démarrage électronique	Elektronisch Anlasser Kit	Kit arranque electrónico	
<b>K</b>	8			Kit avviamento elettrico	Electric starting kit	Kit démarrage électronique	Elektronisch Anlasser Kit	Kit arranque electrónico	
<b>WM</b>	9	8000 A1022	1	Piastra	Plate	Plaquette	Plättchen	Placa	
<b>WC</b>	10	8G00 10904	2	Rosetta	Washer	Rondelle	Scheibe	Arandela	
<b>WM</b>	11	8000 62727	4	Vite	Screw	Vis	Schraube	Tornillo	
<b>M</b>	12	8000 A0746	1	Distanziale	Spacer	Entretoise	Distanzstück	Separador	
	13	66N0 21208	1	Anello elastico	Split ring	Anneau ressort	Sprengring	Anillo elástico	
<b>WC</b>	14	8000 A5895	1	Molla	Spring	Ressort e	Feder	Resorte	
<b>WC</b>	15	8000 A5900	1	Cricchetto scorrevole	Sliding gear	Engrenage	Zahnrad	Engranaje	
	16	8000 61313	1	Dado	Nut	Ecrou	Mutter	Tuerca	
<b>WM</b>	17	8000 A5889	1	Assieme albero avviamento	Starter crank shaft assy	Groupe arbre de démarrage	Kickstarterwellegruppe Kpl.	Grupo eje arranque	
<b>C</b>	18	8000 A6470	1	Distanziale	Spacer	Entretoise	Distanzstück	Separador	
<b>W</b>	27	8000 99956	1	Corona per ruota libera (Z =70) (250)	Ring gear (Z =70) (250)	Couronne (Z =70) (250)	Kranz (Z =70) (250)	Corona (Z =70) (250)	
<b>WM</b>	27	8000 A0739	1	Corona per ruota libera (Z =70) (400-450-510)	Ring gear (Z =70) (400-450-510)	Couronne (Z =70) (400-450-510)	Kranz (Z =70) (400-450-510)	Corona (Z =70) (400-450-510)	
<b>WM</b>	28	8000 35763	1	Gabbia a rullini (ø28xø33x17 mm)	Needle cage (ø28xø33x17 mm)	Cage à aiguilles (ø28xø33x17 mm)	Nadelkaefig (ø28xø33x17 mm)	Casquillo(ø28xø33x17 mm)	
<b>WM</b>	29	8A00 84473	1	Rosetta di rasamento	Washer	Rondelle	Scheibe	Arandela	
<b>W</b>	30	8000 A2933	1	Distanziale (250)	Spacer (250)	Entretoise (250)	Distanzstück (250)	Separador (250)	
<b>WM</b>	30	8000 99957	1	Distanziale (400-450-510)	Spacer (400-450-510)	Entretoise (400-450-510)	Distanzstück (400-450-510)	Separador (400-450-510)	
<b>WM</b>	31	8000 A1279	1	Frizione avviamento elettrico	Electric start clutch	Embraiage demarrage	Anlasser kupplung	Embrague arranque	
<b>WM</b>	32	8000 05876	2	Rosetta	Washer	Rondelle	Scheibe	Arandela	

**TC**

8

1÷5, 7, 9, 11, 12, 27÷33

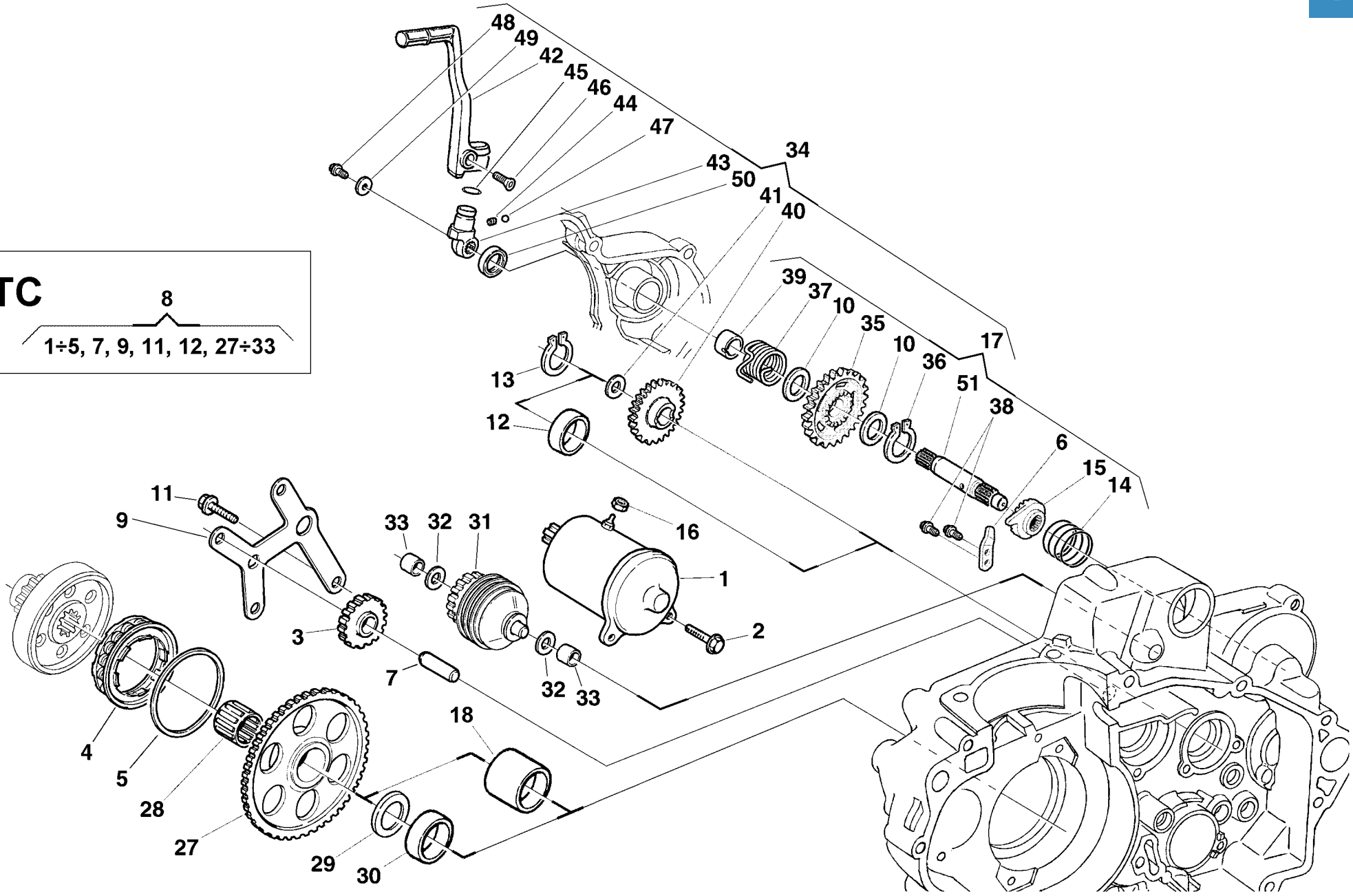

Note Notes Notes Marke Notas	Pos. No. N. Index Pos.	N. Cod. Code No. Nr. Code Code Nr N. Cod.	Q.tà Q.ty Q.te M.ge C.ad	DENOMINAZIONE	NAME	DESIGNATION	BESHREIBUNG	DENOMINACION	Validità Validity Validité Gültig Validez
<b>WM</b>	33	8000 A1017	2	Bussola	Bushing	Douille	Buchse	Manguito	
<b>RM</b>	34	8000 A6088	1	Kit avviamento a pedale	Kick starter kit	Démarrage à pedale	Anlasser mit Kickstarter	Arranque a pedal	
<b>WC</b>	35	8000 A5892	1	Ingranaggio (Z=32)	Gear (Z=32)	Engrenage (Z=32)	Zahn. (Z=32)	Engranaje (Z=32)	
<b>WC</b>	36	66N0 21204	1	Anello SEEGER	Seeger ring	Anneau SEEGER	SEEGER Ring	Anillo SEEGER	
<b>WC</b>	37	8000 A5894	1	Molla rich. leva avviamento	Spring	Ressort	Feder	Resorte	
<b>WC</b>	38	8A00 55241	2	Vite	Screw	Vis	Schraube	Tornillo	
<b>WC</b>	39	8000 A5901	1	Distanziale	Spacer	Entretoise	Distanzstück	Separador	
<b>WC</b>	40	8000 99966	1	Ingranaggio di rinvio (Z=30)	Gear (Z=30)	Engrenage (Z=30)	Zahn. (Z=30)	Engranaje (Z=30)	
<b>WC</b>	41	8B00 07989	1	Rosetta	Washer	Rondelle	Scheibe	Arandela	
<b>WC</b>	42	8000 A4573	1	Pedale avviamento	Pedal	Pedale	Pedal	Pedal	
<b>WC</b>	43	8000 A4574	1	Mozzetto	Hub	Moyeau	Radnabe	Cubo	
<b>WC</b>	44	1611 08401	1	Molla	Spring	Ressort	Feder	Resorte	
<b>WC</b>	45	8000 36380	1	Anello OR	O-Ring	Bague OR	O-Ring	Anillo OR	
<b>WC</b>	46	8000 38287	1	Vite	Screw	Vis	Schraube	Tornillo	
<b>WC</b>	47	6BN0 21507	1	Sfera (1/4")	Ball (1/4")	Bille (1/4")	Kugel (1/4")	Esfera (1/4")	
<b>WC</b>	48	8000 60577	1	Vite	Screw	Vis	Schraube	Tornillo	
<b>WC</b>	49	8000 99973	1	Rosetta	Washer	Rondelle	Scheibe	Arandela	
<b>WC</b>	50	8000 36653	1	Anello di tenuta (ø16x25x4 mm)	Seal ring (ø16x25x4 mm)	Bague d'étanchéité (ø16x25x4 mm)	Dichtungsring (ø16x25x4 mm)	Anillo de retención (ø16x25x4 mm)	
<b>WC</b>	51	8000 A5891	1	Albero avviamento	Starter crank shaft	Arbre de démarrage	Kickstarterwelle	Eje arranque	
<b>k</b>				Parte del kit cod. 8000 A6487 Tavola 2 pos. 10	Contained in kit 8000 A6487 drawing 2 no.10	Contenu in kit no. 8000 A6487 table 2 n. 10	Im Kit Code 8000 A6487 Bild 2 Index 10	Contenido en kit 8000 A6487 tabla 2 pos.10	
<b>K</b>				Parte del kit cod. 8000 A6488 Tavola 2 pos. 10	Contained in kit 8000 A6488 drawing 2 no.10	Contenu in kit no. 8000 A6488 table 2 n. 10	Im Kit Code 8000 A6488 Bild 2 Index 10	Contenido en kit 8000 A6488 tabla 2 pos.10	

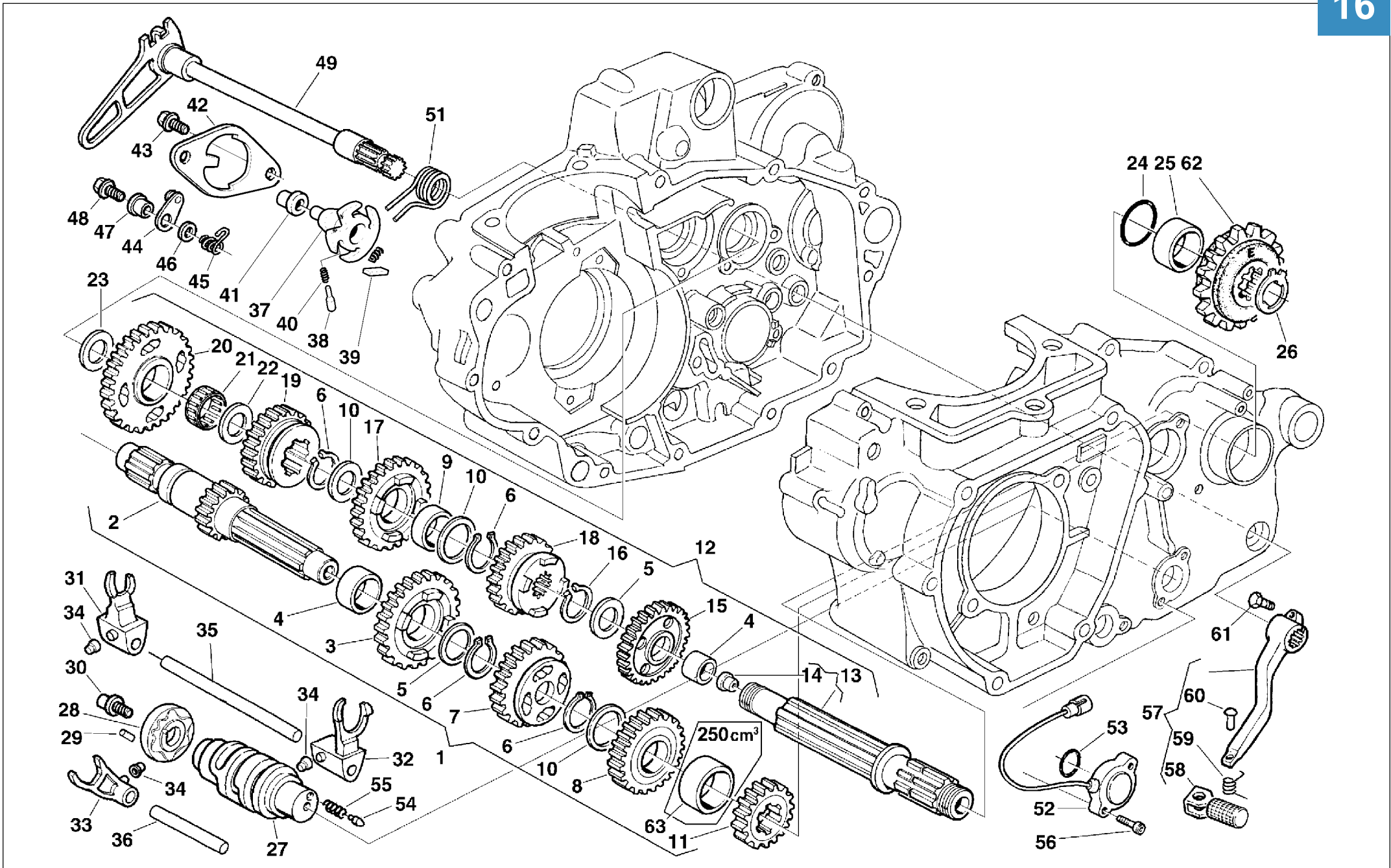



Note Notes Marke Notas	Pos. No. N. Index Pos.	N. Cod. Code No. Nr. Code Code Nr N. Cod.	Q.tà Q.ty Q.te M.ge C.ad	DENOMINAZIONE	NAME	DESIGNATION	BESHREIBUNG	DENOMINACION	Validità Validity Validité Gültig Validez
	1	8000 A1322	1	Albero primario completo (TC 250)	Main shaft (TC 250)	Arbre primaire (TC 250)	Hauptwelle (TC 250)	Eje principal completo (TC 250)	
	1	8000 A5721	1	Albero primario completo (TC 450-510)	Main shaft (TC 450-510)	Arbre primaire (TC 450-510)	Hauptwelle (TC 450-510)	Eje principal completo (TC 450-510)	
	2	8000 A1323	1	Albero primario (Z=15) (TC 250)	Main shaft (Z=15) (TC 250)	Arbre primaire (Z=15) (TC 250)	Hauptwelle (Z=15) (TC 250)	Eje primario (Z=15) (TC 250)	
	2	8000 A4244	1	Albero primario (Z=15) (TC 450-510)	Main shaft (Z=15) (TC 450-510)	Arbre primaire (Z=15) (TC 450-510)	Hauptwelle (Z=15) (TC 450-510)	Eje primario (Z=15) (TC 450-510)	
	3	8000 A1324	1	Ingran. 5ª A.P. (Z=22) (TC 250)	Gear speed (Z=22) (TC 250)	Engrenage 5ème (Z=22) (TC 250)	Zahnrad 5.Gang (Z=22) (TC 250)	Engranaje 5º velocidad (Z=22) (TC 250)	
	3	8000 99782	1	Ingran. 5ª A.P. (Z=22) (TC 450-510)	Gear speed (Z=22) (TC 450-510)	Engrenage 5ème (Z=22) (TC 450-510)	Zahnrad 5.Gang (Z=22) (TC 450-510)	Engranaje 5º velocidad (Z=22) (TC 450-510)	
	4	8000 63822	2	Bussola	Bushing	Douille	Buchse	Manguito	
	5	8D00 36022	2	Rosetta	Washer	Rondelle	Scheibe	Arandela	
	6	8000 31772	4	Anello di fermo	Stop ring	Bague d'arrêt	Haltering	Anillo de retención	
	7	8000 A1325	1	Ingranaggio 3ª A.P. (Z=19) (TC 250)	Main shaft 3rd gear (Z=19) (TC 250)	Engrenage 3ème vitesse A.P. (Z=19) (TC 250)	Zahn. f. 3. Geschw. Antriebsw. (Z=19) (TC 250)	Engranaje 3º velocidad Eje P. (Z=19) (TC 250)	
	7	8000 99783	1	Ingranaggio 3ª A.P. (Z=19) (TC 450-510)	Main shaft 3rd gear (Z=19) (TC 450-510)	Engrenage 3ème vitesse A.P. (Z=19) (TC 450-510)	Zahn. f. 3. Geschw. Antriebsw. (Z=19) (TC 450-510)	Engranaje 3º velocidad Eje P. (Z=19) (TC 450-510)	
	8	8000 A1326	1	Ingranaggio 4ª A.P. (Z=23) (TC 250)	Main shaft 4th gear (Z=23) (TC 250)	Engrenage 4ème vitesse A.P. (Z=23) (TC 250)	Zahn. f. 4. Geschw. Antriebsw. (Z=23) (TC 250)	Engranaje 4º velocidad Eje P. (Z=23) (TC 250)	
	8	8000 99784	1	Ingranaggio 4ª A.P. (Z=23) (TC 450-510)	Main shaft 4th gear (Z=23) (TC 450-510)	Engrenage 4ème vitesse A.P. (Z=23) (TC 450-510)	Zahn. f. 4. Geschw. Antriebsw. (Z=23) (TC 450-510)	Engranaje 4º velocidad Eje P. (Z=23) (TC 450-510)	
	9	8000 63821	2	Bussola	Bushing	Douille	Buchse	Manguito	
	10	8000 88255	3	Rosetta di rasamento	Washer	Rondelle	Scheibe	Arandela	
	11	8000 A1327	1	Ingranaggio 2ª A.P. (Z=17) (TC 250)	Main shaft 2nd gear (Z=17) (TC 250)	Engrenage 2ème vitesse A.P. (Z=17) (TC 250)	Zahn. f. 2. Geschw. Antriebsw. (Z=17) (TC 250)	Engranaje 2º velocidad Eje P. (Z=17) (TC 250)	
	11	8000 A5723	1	Ingranaggio 2ª A.P. (Z=18) (TC 450-510)	Main shaft 2nd gear (Z=18) (TC 450-510)	Engrenage 2ème vitesse A.P. (Z=18) (TC 450-510)	Zahn. f. 2. Geschw. Antriebsw. (Z=18) (TC 450-510)	Engranaje 2º velocidad Eje P. (Z=18) (TC 450-510)	
	12	8000 A1329	1	Albero secondario completo (TC 250)	Layshaft compl. (TC 250)	Arbre secondaire compl. (TC 250)	Vorgelegewelle kpl. (TC 250)	Eje secundario completo (TC 250)	
	12	8000 A5725	1	Albero secondario completo (TC 450-510)	Layshaft compl. (TC 450-510)	Arbre secondaire compl. (TC 450-510)	Vorgelegewelle kpl. (TC 450-510)	Eje secundario completo (TC 450-510)	

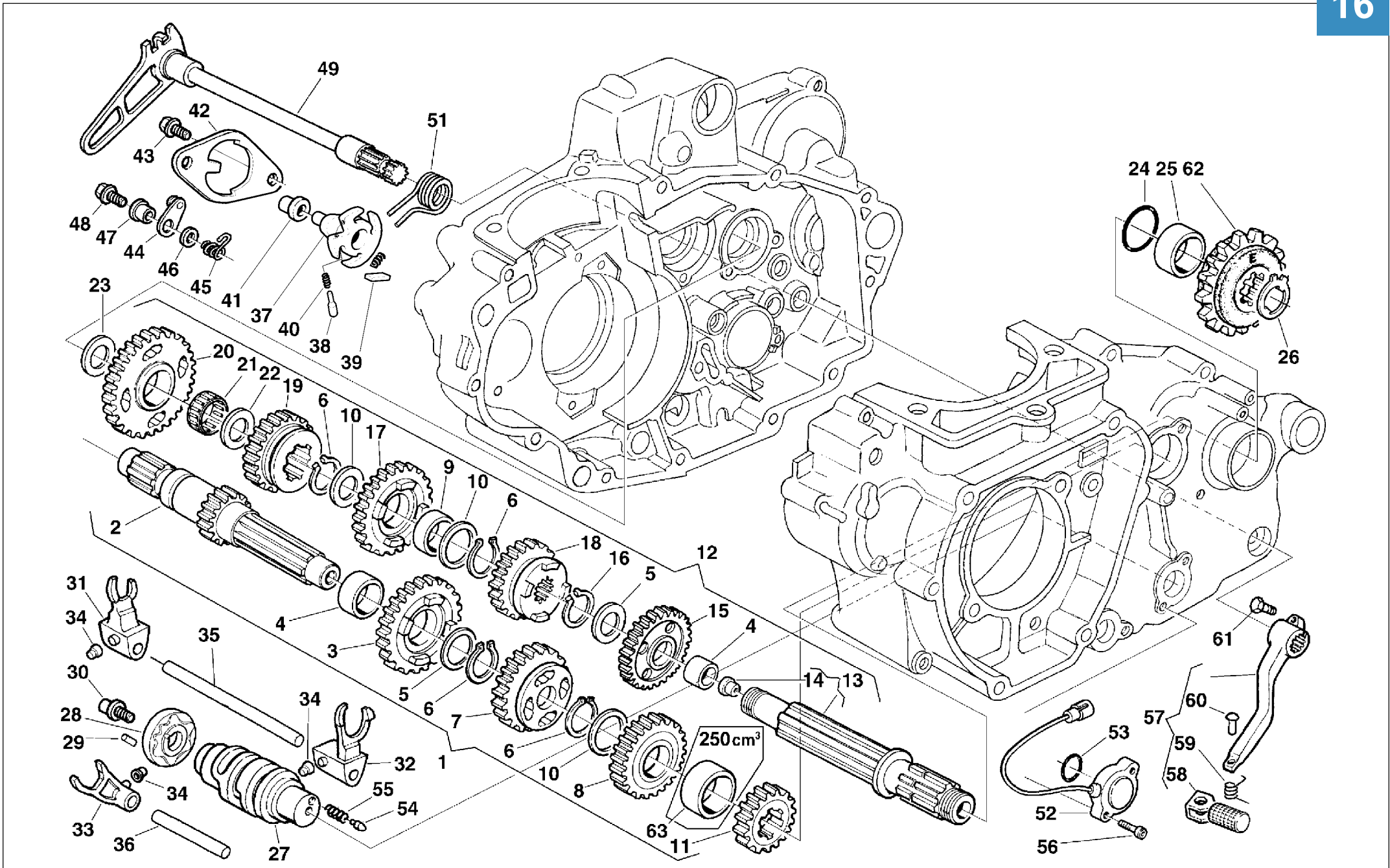

Note Notes Notas	Pos. No. N. Index Pos.	N. Cod. Code No. Nr. Code Code Nr N. Cod.	Q.tà Q.ty Q.te M.ge C.ad	DENOMINAZIONE	NAME	DESIGNATION	BESHREIBUNG	DENOMINACION	Validità Validity Validité Gültig Validez
	13	8000 A1330	1	Albero secondario (TC 250)	Layshaft (TC 250)	Arbre secondaire (TC 250)	Vorgelegewelle (TC 250)	Eje secundario (TC 250)	
	13	8000 99787	1	Albero secondario (TC 450)	Layshaft (TC 450)	Arbre secondaire (TC 450)	Vorgelegewelle (TC 450)	Eje secundario (TC 450)	
	14	8000 57196	1	Tappo	Plug	Bouchon	Verschluss	Tapón	
	15	8000 A1332	1	Ingranaggio 2ª A.S. (Z=26) (TC 250)	Secondary shaft 2nd gear (Z=26) (TC 250)	Engrenage 2ème vitesse A.S. (Z=26) (TC 250)	Zah. f. 2. Geschw. Vorgelegew. (Z=26) (TC 250)	Engranaje 2º velocidad Eje S. (Z=26) (TC 250)	
	15	8000 A5724	1	Ingranaggio 2ª A.S. (Z=26) (TC 450-510)	Secondary shaft 2nd gear (Z=26) (TC 450-510)	Engrenage 2ème vitesse A.S. (Z=26) (TC 450-510)	Zah. f.2. Geschw. Vorgelegew. (Z=26) (TC 450-510)	Engranaje 2º velocidad Eje S. (Z=26) (TC 450-510)	
	16	66N0 21211	3	Anello di fermo	Stop ring	Bague d'arrêt	Haltering	Anillo de retención	
	17	8000 A1333	1	Ingranaggio 3ª A.S. (Z=24) (TC 250)	Secondary shaft 3rd gear (Z=24) (TC 250)	Engrenage 3ème vitesse A.S. (Z=24) (TC 250)	Zah. f. 3. Geschw. Vorgelegew. (Z=24) (TC 250)	Engranaje 3º velocidad Eje S. (Z=24) (TC 250)	
	17	8000 99790	1	Ingranaggio 3ª A.S. (Z=24) (TC 450-510)	Secondary shaft 3rd gear (Z=24) (TC 450-510)	Engrenage 3ème vitesse A.S. (Z=24) (TC 450-510)	Zah. f.3. Geschw. Vorgelegew. (Z=24) (TC 450-510)	Engranaje 3º velocidad Eje S. (Z=24) (TC 450-510)	
	18	8000 A1334	1	Ingranaggio 4ª A.S. (Z=25) (TC 250)	Secondary shaft 4th gear (Z=25) (TC 250)	Engrenage 4ème vitesse A.S. (Z=25) (TC 250)	Zah. f. 4. Geschw. Vorgelegew. (Z=25) (TC 250)	Engranaje 4º velocidad Eje S. (Z=25) (TC 250)	
	18	8000 A1914	1	Ingranaggio 4ª A.S. (Z=25) (TC 450-510)	Secondary shaft 4th gear (Z=25) (TC 450-510)	Engrenage 4ème vitesse A.S. (Z=25) (TC 450-510)	Zah. f.4. Geschw. Vorgelegew. (Z=25) (TC 450-510)	Engranaje 4º velocidad Eje S. (Z=25) (TC 450-510)	
	19	8000 A1335	1	Ingranaggio 5ª A.S. (Z=21) (TC 250)	Secondary shaft 5th gear (Z=21) (TC 250)	Engrenage 5ème vitesse A.S. (Z=21) (TC 250)	Zah. f. 5. Geschw. Vorgelegew. (Z=21) (TC 250)	Engranaje 5º velocidad Eje S. (Z=21) (TC 250)	
	19	8000 A1915	1	Ingranaggio 5ª A.S. (Z=21) (TC 450-510)	Secondary shaft 5th gear (Z=21) (TC 450-510)	Engrenage 5ème vitesse A.S. (Z=21) (TC 450-510)	Zah. f.5. Geschw. Vorgelegew. (Z=21) (TC 450-510)	Engranaje 5º velocidad Eje S. (Z=21) (TC 450-510)	
	20	8000 A1336	1	Ingranaggio 1ª A.S. (Z=28) (TC 250)	Gear 1st speed (Z=28) (TC 250)	Engranage 1ère (Z=28) (TC 250)	Zahnrad 1. Gang (Z=28) (TC 250)	Engranaje 1º velocidad (Z=28) (TC 250)	
	20	8000 A1916	1	Ingranaggio 1ª A.S. (Z=28) (TC 450-510)	Gear 1st speed (Z=28) (TC 450-510)	Engranage 1ère (Z=28) (TC 450-510)	Zahnrad 1. Gang (Z=28) (TC 450-510)	Engranaje 1º velocidad (Z=28) (TC 450-510)	
	21	8000 22373	1	Gabbia a rullini (ø20xø24x10 mm)	Needle cage (ø20xø24x10 mm)	Cage à aiguilles (ø20xø24x10 mm)	Nadelkaefig (ø20xø24x10 mm)	Casquillo(ø20xø24x10 mm)	
	22	8G00 07989	1	Rosetta	Washer	Rondelle	Scheibe	Arandela	
	23	8G00 07989	1	Rosetta	Washer	Rondelle	Scheibe	Arandela	
	24	8000 41693	1	Anello OR	O-Ring	Bague OR	O-Ring	Anillo OR	
	25	8000 86953	1	Distanziale	Spacer	Entretoise	Distanzstück	Separador	
	26	66N0 21211	1	Anello di fermo	Stop ring	Bague d'arrêt	Haltering	Anillo de retención	

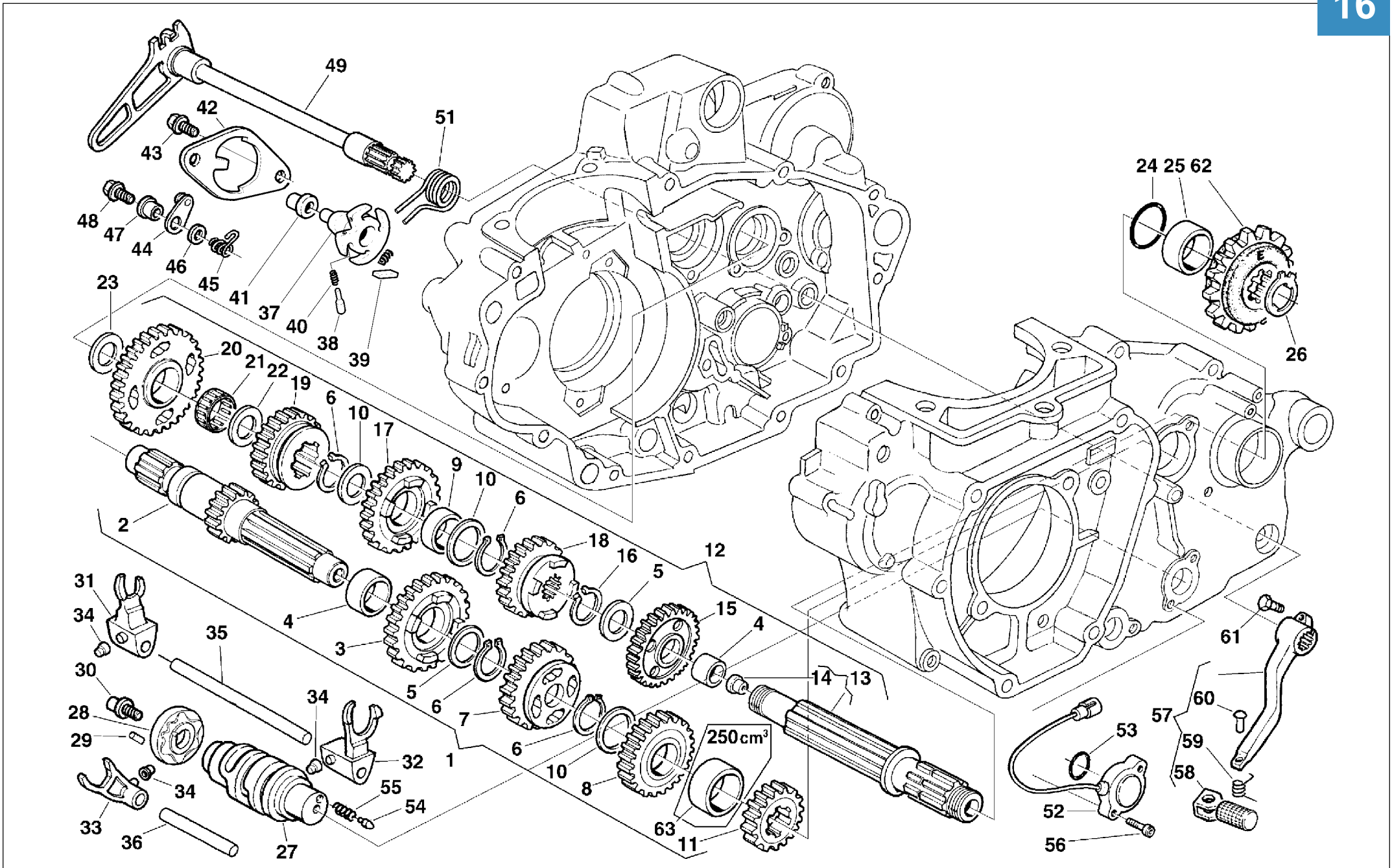

Note Notes Notas	Pos. No. N. Index Pos.	N. Cod. Code No. Nr. Code Code Nr N. Cod.	Q.tà Q.ty Q.te M.ge C.ad	DENOMINAZIONE	NAME	DESIGNATION	BESHREIBUNG	DENOMINACION	Validità Validity Validité Gültig Validez
	27	8000 99919	1	Albero forcelle cambio	Driving shaft gearbox forks	Arbre comm. fourches trans.	Antriebswelle Schaltgabel	Eje mando horquilla cambio	
	28	8A00 97739	1	Tamburo selettore marce	Drum	Tambour	Trommel	T%ambor	
	29	8000 38520	1	Rullino	Roller	Aiguille	Rolle	Rodillo	
	30	8000 98149	1	Vite	Screw	Vis	Schraube	Tornillo	
	31	8000 A0091	1	Forcella cambio (1 <sup>a</sup> -4 <sup>a</sup> )	Fork (1st-4st)	Fourche (1ère-4ème)	Gabel (1-4)	Horquilla (1°-4° )	
	32	8000 A0092	1	Forcella cambio (2 <sup>a</sup> -3 <sup>a</sup> )	Fork (2nd-3rd)	Fourche (2ème-3ème)	Gabel (2-3)	Horquilla (2°-3° )	
	33	8000 99738	1	Forcella cambio (5 <sup>a</sup> )	Fork (5th)	Fourche (5ème)	Gabel (5)	Horquilla (5°)	
	34	8000 71010	3	Rotella	Disc	Disque	Scheibe	Disco	
	35	8000 38711	1	Perno (L=96 mm)	Pin (L=96 mm)	Pivot (L=96 mm)	Bolzen (L=96 mm)	Perno (L=96 mm)	
	36	8000 38712	1	Perno (L=57 mm)	Pin (L=57 mm)	Pivot (L=57 mm)	Bolzen (L=57 mm)	Perno (L=57 mm)	
	37	8000 87299	1	Rocchetto selettore dentato	Sprocket	Rochet	Spule	Piñon	
	38	8000 71007	2	Saltarello per rocchetto	Click	Cliquet	Strumhaken	Salt.	
	39	8000 71008	2	Puntale per saltarello	Push rod	Embout	Stösselschaft	Puntal	
	40	8000 71009	2	Molla	Spring	Ressort	Feder	Resorte	
	41	8000 71010	1	Rotella	Disc	Disque	Scheibe	Disco	
	42	8000 99739	1	Piastrina	Plate	Plaque	Platte	Placa	
	43	8000 62726	2	Vite	Screw	Vis	Schraube	Tornillo	
	44	8000 85495	1	Saltarello fissamarce	Click	Cliquet	Strumhaken	Salt.	
	45	8000 A1748	1	Molla	Spring	Ressort	Feder	Resorte	
	46	8000 86107	1	Rosetta di rasamento	Washer	Rondelle	Scheibe	Arandela	
	47	8000 85493	1	Bussola	Bushing	Douille	Buchse	Manguito	
	48	8000 62726	1	Vite	Screw	Vis	Schraube	Tornillo	
	49	8000 91559	1	Albero com. selettore	Gearbox pedal shaft assy	Arbre péd. change vit. compl.	Umsteuerungswelle kpl.	Eje pedal cambio compl.	
	51	8000 72826	1	Molla	Spring	Ressort	Feder	Resorte	
	52	8000 A4511	1	Segnalatore marce	Idle trasponder assy	Signaleur point mort compl.	Leerlaufflicht kpl.	Señalador compl.	
	53	8A00 42700	1	Anello OR	O-Ring	Bague OR	O-Ring	Anillo OR	
	54	8000 42676	1	Puntale per segnalatore marce	Push rod	Embout	Stösselschaft	Puntal	
	55	8000 42677	1	Molla	Spring	Ressort	Feder	Resorte	
	56	8000 66525	2	Vite	Screw	Vis	Schraube	Tornillo	
E	57	8000 99741	1	Leva comando cambio	Gearchange lever assy	Levier comm. vitesse compl.	Schalthebel kpl.	Palanca del cambio compl.	
	57	8000 A3488	1	Leva comando cambio	Gearchange lever assy	Levier comm. vitesse compl.	Schalthebel kpl.	Palanca del cambio compl.	
E	58	8000 A3485	1	Pedale leva comando cambio	Gearchange lever pedal	Pedale	Pedal	Pedal	
	58	8A00 A3485	1	Pedale leva comando cambio	Gearchange lever pedal	Pedale	Pedal	Pedal	



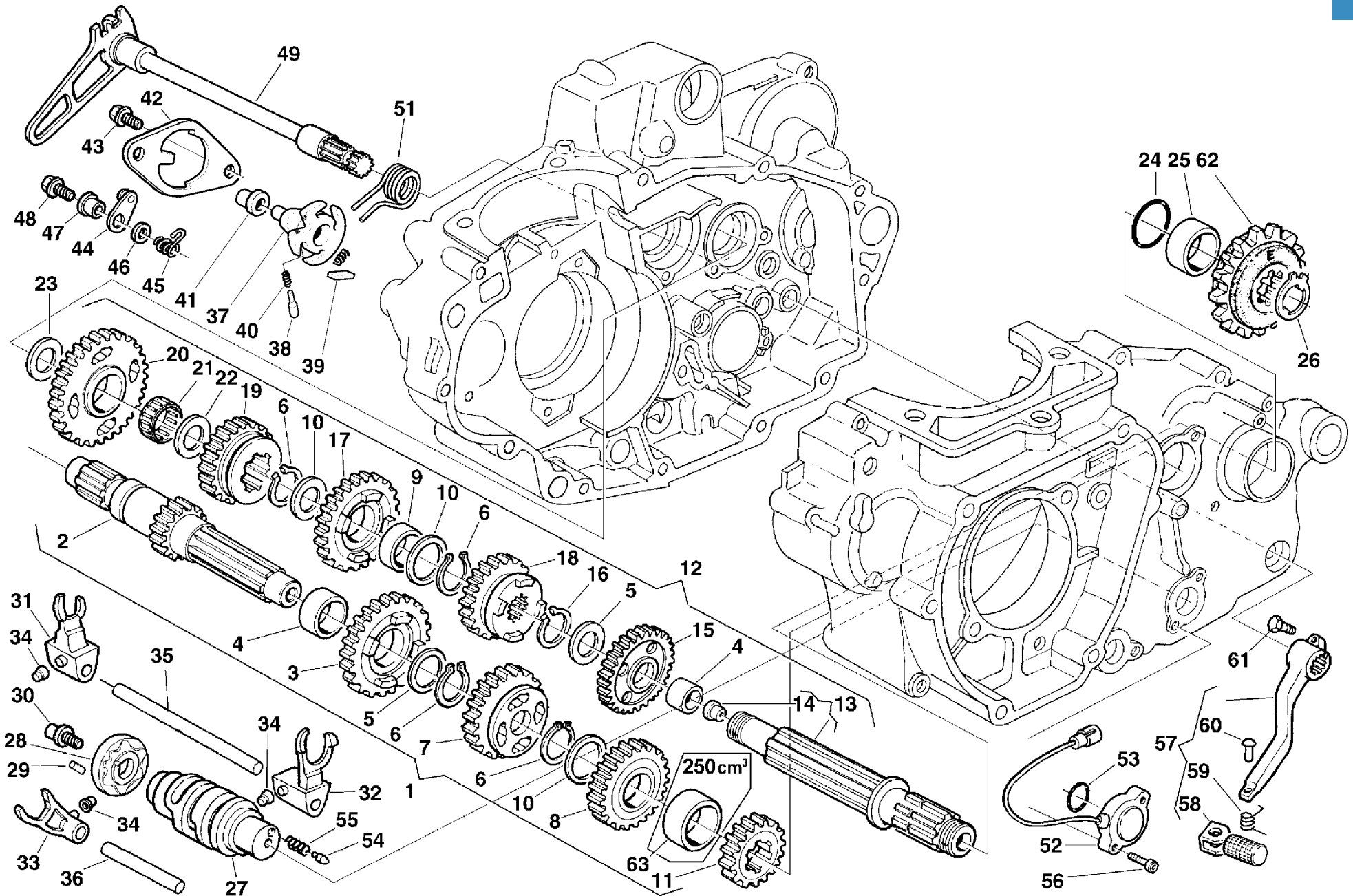



Note Notes Marke Notas	Pos. No. N. Index Pos.	N. Cod. Code No. Nr. Code Code Nr N. Cod.	Q.tà Q.ty Q.te M.ge C.ad	DENOMINAZIONE	NAME	DESIGNATION	BESHREIBUNG	DENOMINACION	Validità Validity Validité Gültig Validez
	59	8000 70216	1	Molla	Spring	Ressort	Feder	Resorte	
	60	8000 99744	1	Ribattino	Rivet	Rivet	Niet	Remache	
	61	8000 62728	1	Vite	Screw	Vis	Schraube	Tornillo	
<b>R</b>	62	8000 63827	1	Pignone Z=12 (250)	Pinion Z=12	Pignon Z=12	Ritzel Z=12	Piñón Z=12	
<b>R</b>	62	8000 63828	1	Pignone Z=13	Pinion Z=13	Pignon Z=13	Ritzel Z=13	Piñón Z=13	
<b>R</b>	62	8000 63829	1	Pignone Z=14 (450-510)	Pinion Z=14 (450-510)	Pignon Z=14 (450-510)	Ritzel Z=14 (450-510)	Piñón Z=14 (450-510)	
<b>R</b>	62	8000 63830	1	Pignone Z=15	Pinion Z=15	Pignon Z=15	Ritzel Z=15	Piñón Z=15	
<b>RY</b>	62	8000 63831	1	Pignone Z=16	Pinion Z=16	Pignon Z=16	Ritzel Z=16	Piñón Z=16	
	63	8000 A1328	1	Distanziale (TC 250)	Spacer (TC 250)	Entretoise (TC 250)	Distanzstück (TC 250)	Separador (TC 250)	

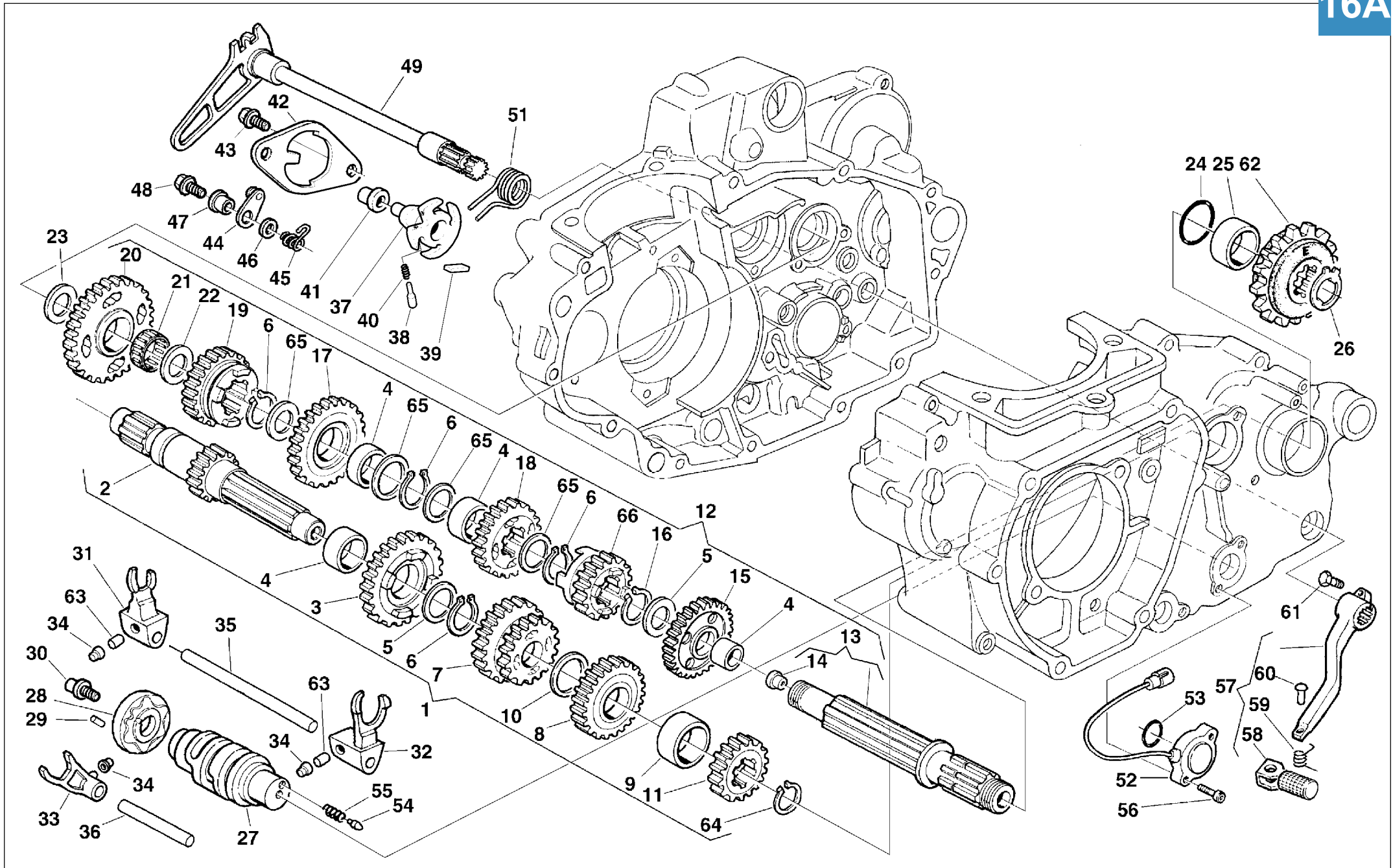

Note Notes Notas	Pos. No. N. Index Pos.	N. Cod. Code No. Nr. Code Code Nr N. Cod.	Q.tà Q.ty Q.te M.ge C.ad	DENOMINAZIONE	NAME	DESIGNATION	BESHREIBUNG	DENOMINACION	Validità Validity Validité Gultig Validez
	1	8000 A4592	1	Albero primario completo (250)	Main shaft (250)	Arbre primaire (250)	Hauptwelle (250)	Eje principal completo (250)	
	1	8000 A3511	1	Albero primario completo (400-450-510)	Main shaft (250) (400-450-510)	Arbre primaire (400-450-510)	Hauptwelle (400-450-510)	Eje principal completo (400-450-510)	
	2	8000 A1300	1	Albero primario (Z=14)	Main shaft (Z=14)	Arbre primaire (Z=14)	Hauptwelle (Z=14)	Eje primario (Z=14)	
	2	8000 A3512	1	Albero primario (Z=14) (400-450-510)	Main shaft (Z=14) (400-450-510)	Arbre primaire (Z=14) (400-450-510)	Hauptwelle (Z=14) (400-450-510)	Eje primario (Z=14) (400-450-510)	
	3	8000 88244	1	Ingran. 5ª A.P. (Z=25)	Gear 5th - 6th speed (Z=25)	Engrenage 5ème (Z=25)	Zahnrad 5.Gang (Z=25)	Engranaje 5º velocidad (Z=25)	
	4	8000 63822	5	Bussola	Bushing	Douille	Buchse	Manguito	
	5	8D00 36022	2	Rosetta	Washer	Rondelle	Scheibe	Arandela	
	6	8000 31772	4	Anello di fermo	Stop ring	Bague d'arrêt	Haltering	Anillo de retención	
	7	8000 A3972	1	Ingranaggio 3ª-4ª A.P. (Z=18, Z=23)	Main shaft 3rd- 4th gear (Z=18, Z=23)	Engrenage 3ème- 4ème vitesse A.P. (Z=18, Z=23)	Zahn. f. 3.- 4. Geschw. Antriebsw. (Z=18, Z=23)	Engranaje 3º - 4º velocidad Eje P.(Z=18, Z=23)	
	8	8000 88246	1	Ingranaggio 6ª A.P. (Z=27)	Main shaft 6th gear (Z=27)	Engrenage 6ème vitesse A.P. (Z=27)	Zahn. f. 6. Geschw. Antriebsw. (Z=27)	Engranaje 6º velocidad Eje P. (Z=27)	
	9	8A00 61261	1	Bussola	Bushing	Douille	Buchse	Manguito	
	10	8B00 36023	1	Rosetta di rasamento	Washer	Rondelle	Scheibe	Arandela	
	11	8000 88247	1	Ingranaggio 2ª A.P. (Z=18)	Main shaft 2nd gear (Z=18)	Engr.2ème vitesse A.P. (Z=18)	Zahn. f. 2. Geschw. Antriebsw. (Z=18)	Engranaje 2º velocidad Eje P. (Z=18)	
	12	8000 A3971	1	Albero secondario compl. (250)	Layshaft compl. (250)	Arbre secondaire compl. (250)	Vorgelegewelle kpl. (250)	Eje secundario compl. (250)	
	13	8000 A1302	1	Albero secondario	Layshaft	Arbre secondaire	Vorgelegewelle	Eje secundario	
	14	8000 57196	1	Tappo	Plug	Bouchon	Verschluss	Tapón	
	15	8000 A1918	1	Ingranaggio 2ª A.S. (Z=29)	Secondary shaft 2nd gear (Z=29)	Engrenage 2ème vitesse A.S. (Z=29)	Zah. f. 2. Geschw. Vorgelegew. (Z=29)	Engranaje 2º velocidad Eje S. (Z=29)	
	16	66N0 21211	3	Anello di fermo	Stop ring	Bague d'arrêt	Haltering	Anillo de retención	
	17	8000 88254	1	Ingranaggio 4ª A.S. (Z=25)	Secondary shaft 4th gear (Z=25)	Engrenage 4ème vitesse A.S. (Z=25)	Zah. f. 4. Geschw. Vorgelegew. (Z=25)	Engranaje 4º velocidad Eje S. (Z=25)	
	18	8000 A3970	1	Ingranaggio 3ª A.S. (Z=24)	Secondary shaft 3rd gear (Z=24)	Engrenage 3ème vitesse A.S. (Z=24)	Zah. f. 3. Geschw. Vorgelegew. (Z=24)	Engranaje 3º velocidad Eje S. (Z=24)	
	19	8000 A1920	1	Ingranaggio 5ª A.S. (Z=23)	Secondary shaft 5th gear (Z=23)	Engrenage 5ème vitesse A.S. (Z=23)	Zah. f. 5. Geschw. Vorgelegew. (Z=23)	Engranaje 5º velocidad Eje S. (Z=23)	
	20	8000 A1921	1	Ingranaggio 1ª A.S. (Z=28)	Gear 1st speed (Z=28)	Engrenage 1ère (Z=28)	Zahnrad 1. Gang (Z=28)	Engranaje 1º velocidad (Z=28)	

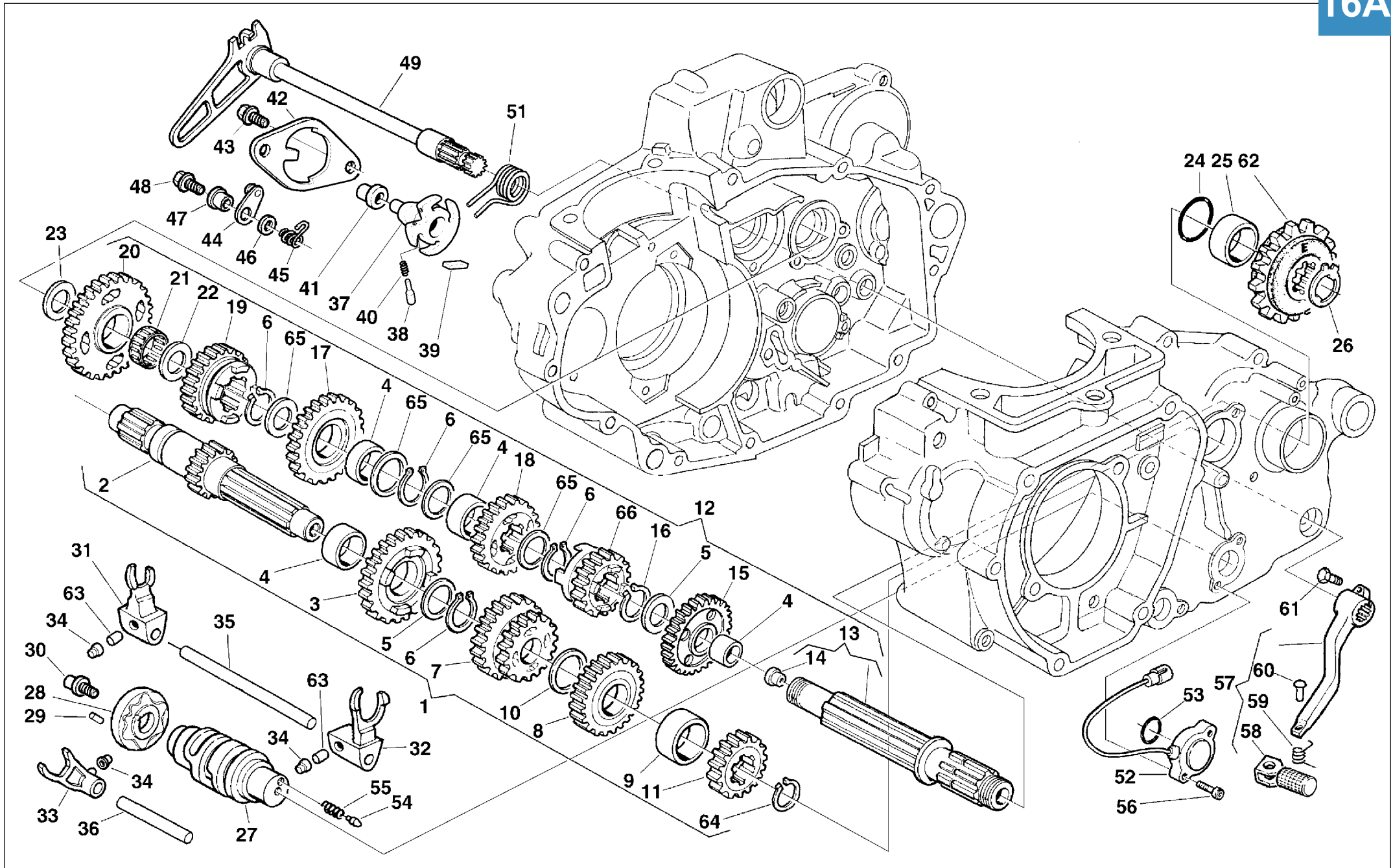

Note Notes Notas	Pos. No. N. Index Pos.	N. Cod. Code No. Nr. Code Code Nr N. Cod.	Q.tà Q.ty Q.te M.ge C.ad	DENOMINAZIONE	NAME	DESIGNATION	BESHREIBUNG	DENOMINACION	Validità Validity Validité Gültig Validez
	21	8000 22373	1	Gabbia a rullini (ø20xø24x10 mm)	Needle cage (ø20xø24x10 mm)	Cage à aiguilles (ø20xø24x10 mm)	Nadelkaefig (ø20xø24x10 mm)	Casquillo(ø20xø24x10 mm)	
	22	8G00 07989	1	Rosetta	Washer	Rondelle	Scheibe	Arandela	
	23	8G00 32069	1	Rosetta	Washer	Rondelle	Scheibe	Arandela	
	24	8000 41693	1	Anello OR	O-Ring	Bague OR	O-Ring	Anillo OR	
	25	8000 86953	1	Distanziale	Spacer	Entretoise	Distanzstück	Separador	
	26	66N0 21211	1	Anello di fermo	Stop ring	Bague d'arrêt	Haltering	Anillo de retención	
	27	8000 A1316	1	Albero forcelle cambio	Driving shaft gearbox forks	Arbre comm. fourches trans.	Antriebswelle Schaltgabel	Eje mando horquilla cambio	
	28	8A00 97739	1	Tamburo selettore marce	Drum	Tambour	Trommel	T%ambor	
	29	8000 38520	1	Rullino	Roller	Aiguille	Rolle	Rodillo	
	30	8000 98149	1	Vite	Screw	Vis	Schraube	Tornillo	
	31	8A00 86980	1	Forcella cambio (1 <sup>a</sup> -4 <sup>a</sup> )	Fork (1 <sup>a</sup> -4 <sup>a</sup> )	Fourche (1 <sup>a</sup> -4 <sup>a</sup> )	Gabel (1 <sup>a</sup> -4 <sup>a</sup> )	Horquilla (1 <sup>a</sup> -4 <sup>a</sup> )	
	32	8A00 48127	1	Forcella cambio (2 <sup>a</sup> -3 <sup>a</sup> )	Fork (2nd-3rd)	Fourche (2ème-3ème)	Gabel (2-3)	Horquilla (2 <sup>o</sup> -3 <sup>o</sup> )	
	33	8000 99738	1	Forcella cambio (5 <sup>a</sup> -6 <sup>a</sup> )	Fork (5th-6th)	Fourche (5ème-6ème)	Gabel (5-6)	Horquilla (5 <sup>o</sup> -6 <sup>o</sup> )	
	34	8000 71010	3	Rotella	Disc	Disque	Scheibe	Disco	
	35	8000 38711	1	Perno (L=96 mm)	Pin (L=96 mm)	Pivot (L=96 mm)	Bolzen (L=96 mm)	Perno (L=96 mm)	
	36	8000 38712	1	Perno (L=57 mm)	Pin (L=57 mm)	Pivot (L=57 mm)	Bolzen (L=57 mm)	Perno (L=57 mm)	
	37	8000 87299	1	Rocchetto selettore dentato	Sprocket	Rochet	Spule	Piñon	
	38	8000 71007	2	Saltarello per rocchetto	Click	Cliquet	Strumhaken	Salt.	
	39	8000 71008	2	Puntale per saltarello	Push rod	Embout	Stösselschaft	Puntal	
	40	8000 71009	2	Molla	Spring	Ressort	Feder	Resorte	
	41	8000 71010	1	Rotella	Disc	Disque	Scheibe	Disco	
	42	8000 99739	1	Piastrina	Plate	Plaque	Platte	Placa	
	43	8000 62726	2	Vite	Screw	Vis	Schraube	Tornillo	
	44	8000 85495	1	Saltarello fissamarce	Click	Cliquet	Strumhaken	Salt.	
	45	8000 A1748	1	Molla	Spring	Ressort	Feder	Resorte	
	46	8000 86107	1	Rosetta di rasamento	Washer	Rondelle	Scheibe	Arandela	
	47	8000 85493	1	Bussola	Bushing	Douille	Buchse	Manguito	
	48	8000 62726	1	Vite	Screw	Vis	Schraube	Tornillo	
	49	8000 91559	1	Albero com. selettore	Gearbox pedal shaft assy	Arbre péd. change vit. compl.	Umsteuerungswelle kpl.	Eje pedal cambio compl.	
	51	8000 72826	1	Molla	Spring	Ressort	Feder	Resorte	
	52	8000 A4511	1	Segnalatore marce	Idle trasponder	Signaleur vitesses	Leerlauflicht	Señalador	
	53	8A00 42700	1	Anello OR	O-Ring	Bague OR	O-Ring	Anillo OR	



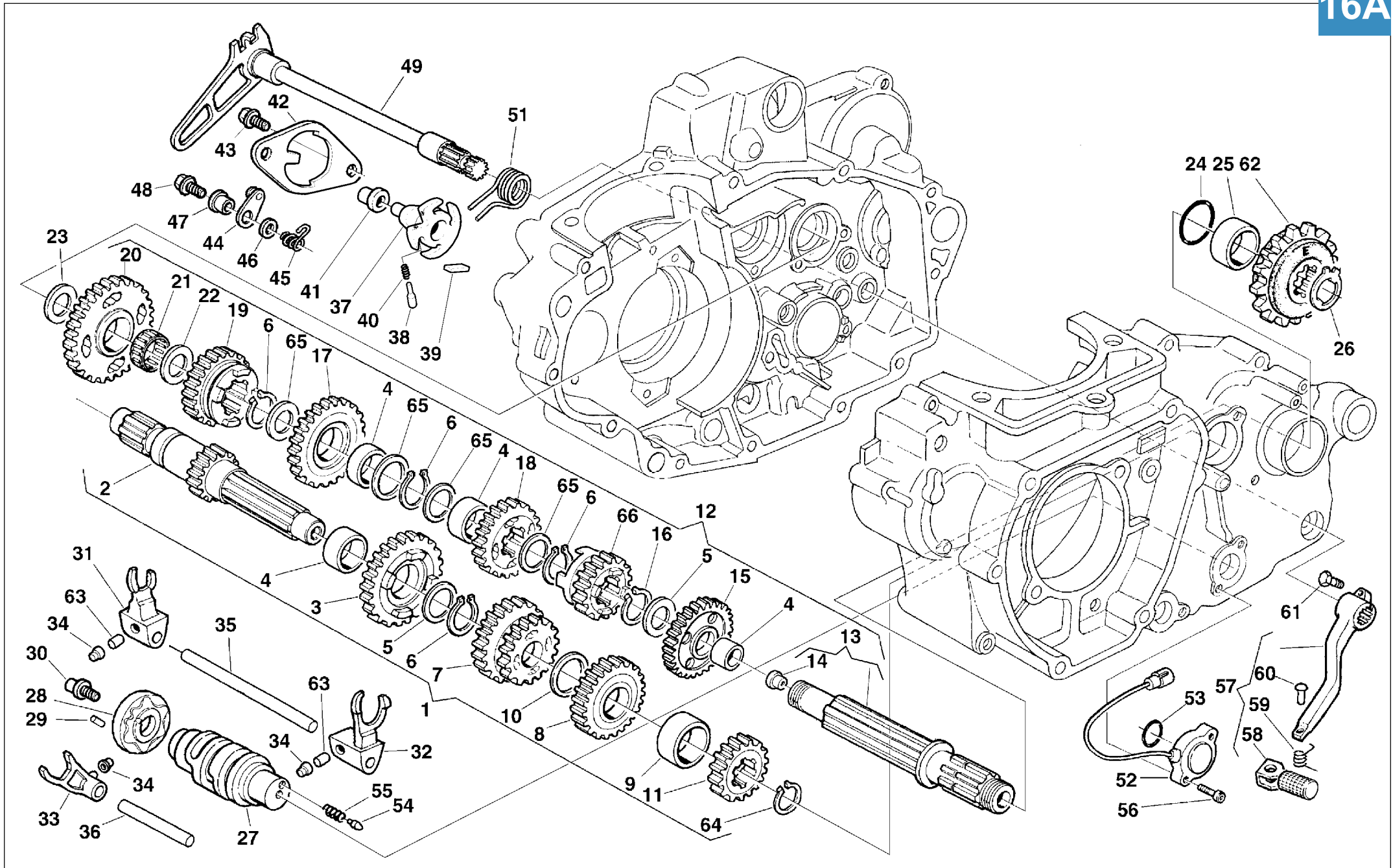



Note Notes Markes Notas	Pos. No. N. Index Pos.	N. Cod. Code No. Nr. Code Code Nr N. Cod.	Q.tà Q.ty Q.te M.ge C.ad	DENOMINAZIONE	NAME	DESIGNATION	BESHREIBUNG	DENOMINACION	Validità Validity Validité Gültig Validez
	54	8000 42676	1	Puntale per segnalatore marce	Push rod	Embout	Stösselschaft	Puntal	
	55	8000 42677	1	Molla	Spring	Ressort	Feder	Resorte	
	56	8000 66525	2	Vite	Screw	Vis	Schraube	Tornillo	
<b>E</b>	57	8000 99741	1	Leva comando cambio	Gearchange lever assy	Levier comm. vitesse compl.	Schalthebel kpl.	Palanca del cambio compl.	
	57	8000 A3488	1	Leva comando cambio	Gearchange lever assy	Levier comm. vitesse compl.	Schalthebel kpl.	Palanca del cambio compl.	
<b>E</b>	58	8000 A3485	1	Pedale leva comando cambio	Gearchange lever pedal	Pedale	Pedal	Pedal	
	58	8A00 A3485	1	Pedale leva comando cambio	Gearchange lever pedal	Pedale	Pedal	Pedal	
	59	8000 70216	1	Molla	Spring	Ressort	Feder	Resorte	
	60	8000 99744	1	Ribattino	Rivet	Rivet	Niet	Remache	
	61	8000 62728	1	Vite	Screw	Vis	Schraube	Tornillo	
<b>R</b>	62	8000 63827	1	Pignone Z=12	Pinion Z=12	Pignon Z=12	Ritzel Z=12	Piñón Z=12	
	62	8000 63828	1	Pignone Z=13 (TE 250-450)	Pinion Z=13 (TE 250-450)	Pignon Z=13 (TE 250-450)	Ritzel Z=13 (TE 250-450)	Piñón Z=13 (TE 250-450)	
	62	8000 63829	1	Pignone Z=14 (TE 510, SM)	Pinion Z=14 (TE 510, SM)	Pignon Z=14 (TE 510, SM)	Ritzel Z=14 (TE 510, SM)	Piñón Z=14 (TE 510, SM)	
	62	8000 63830	1	Pignone Z=15	Pinion Z=15	Pignon Z=15	Ritzel Z=15	Piñón Z=15	
<b>D</b>	62	8000 63831	1	Pignone Z=16	Pinion Z=16	Pignon Z=16	Ritzel Z=16	Piñón Z=16	
	63	8000 38728	2	Rullino	Roller	Aiguille	Rolle	Rodillo	
	64	66N0 21206	1	Anello di fermo	Stop ring	Bague d'arrêt	Haltering	Anillo de retención	
	65	8000 88255	4	Rosetta di rasamento	Washer	Rondelle	Scheibe	Arandela	
	66	8000 A1919	1	Ingranaggio 6 <sup>a</sup> A.S. (Z=22)	Secondary shaft 6th gear (Z=22)	Engrenage 6ème vitesse A.S. (Z=22)	Zahnr. f. 6. Geschw. Vorgelegew. (Z=22)	Engranaje 6 <sup>o</sup> velocidad Eje S. (Z=22)	

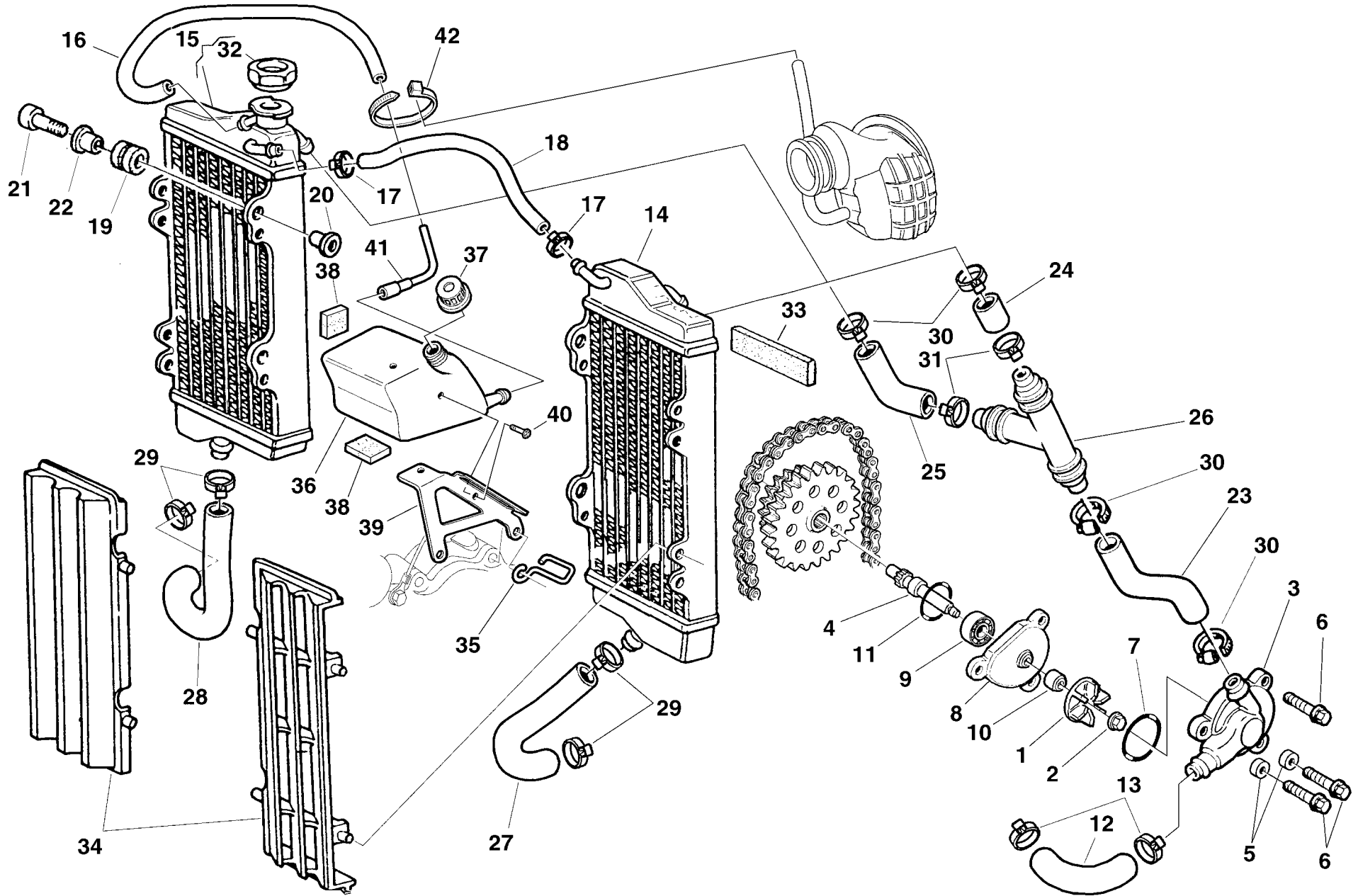

Note Notes Notas	Pos. No. N. Index Pos.	N. Cod. Code No. Nr. Code Code Nr N. Cod.	Q.tà Q.ty Q.te M.ge C.ad	DENOMINAZIONE	NAME	DESIGNATION	BESHREIBUNG	DENOMINACION	Validità Validity Validité Gültig Validez
	1	8A00 60415	1	Girante (250-400)	Rotor (250-400)	Couronne (250-400)	Laufgrad (250-400)	Rotor (250-400)	
	1	8000 78442	1	Girante (450-510)	Rotor (450-510)	Couronne (450-510)	Laufgrad (450-510)	Rotor (450-510)	
	2	8000 42278	1	Dado	Nut	Ecrou	Mutter	Tuerca	
	3	8000 91564	1	Corpo pompa	Pump body	Corps pompe	Pumpenkörper	Corpo bomba	
	4	8000 A4789	1	Albero pompa acqua	Water pump shaft	Arbre	Welle	Eje	
	5	1617 95501	2	Bussola	Bushing	Douille	Buchse	Manguito	
	6	8000 62730	3	Vite (M6x30 mm)	Screw (M6x30 mm)	Vis (M6x30 mm)	Schraube (M6x30 mm)	Tornillo (M6x30 mm)	
	7	8000 27122	1	Anello OR	O-Ring	Bague OR	O-Ring	Anillo OR	
	8	8000 91565	1	Flangia	Flange	Bride	Flansch	Brida	
	9	8000 34317	1	Cuscinetto (ø12xø28x8 mm)	Bearing (ø12xø28x8 mm)	Roulement (ø12xø28x8 mm)	Lager (ø12xø28x8 mm)	Cojinete (ø12xø28x8 mm)	
	10	8000 53339	1	Anello di tenuta (ø8xø16x10 mm)	Seal ring (ø8xø16x10 mm)	Bague d'étanchéité (ø8xø16x10 mm)	Dichtungsring (ø8xø16x10 mm)	Anillo de retención (ø8xø16x10 mm)	
	11	8000 40007	1	Anello OR	O-Ring	Bague OR	O-Ring	Anillo OR	
	12	8000 99708	1	Tubo testa-pompa (250-400)	Pipe (250-400)	Tuyau (250-400)	Schlauch (250-400)	Tubo (250-400)	
	12	8A00 99708	1	Tubo testa-pompa (450-510)	Pipe (450-510)	Tuyau (450-510)	Schlauch (450-510)	Tubo (450-510)	
	13	8B00 99475	2	Fascetta	Clamp	Collier	Schelle	Banda	
	14	8000 99659	1	Radiatore SINISTRO	L.H. radiator	Radiateur G.	L., Kühler	Radiador izrdo.	
	15	8000 99658	1	Radiatore DESTRO completo	R.H. radiator compl.	Radiateur D. compl.	R., Kühler kpl.	Radiador derech. compl.	
<b>C</b>	16	8B00 43715	1	Tubetto sfiato	Tube	Tuyau	Rohr	Tubo	
	17	8000 56462	2	Fascetta	Clamp	Collier	Schelle	Banda	
	18	8D00 43716	1	Tubo	Pipe	Tuyau	Schlauch	Tubo	
	19	8000 59803	6	Gommino	Rubber pad	Pièce caoutchouc	Gummstück	Junta de goma	
	20	8000 59802	6	Bussola	Bushing	Douille	Buchse	Manguito	
	21	8000 62728	6	Vite (M6x20 mm)	Screw (M6x20 mm)	Vis (M6x20 mm)	Schraube (M6x20 mm)	Tornillo (M6x20 mm)	
	22	8000 59801	6	Rosetta piana	Washer	Rondelle	Scheibe	Arandela	
	23	8000 99660	1	Tubo POMPA-RACCORDO (TE-TC 250)	Pipe (TE-TC 250)	Tuyau (TE-TC 250)	Schlauch (TE-TC 250)	Tubo (TE-TC 250)	
	23	8A00 99660	1	Tubo POMPA-RACCORDO (400-450-510)	Pipe (400-450-510)	Tuyau (400-450-510)	Schlauch (400-450-510)	Tubo (400-450-510)	
	24	8000 A0669	1	Tubo RAD. SX-RACCORDO	Pipe	Tuyau	Schlauch	Tubo	
	25	8000 A0670	1	Tubo RAD. DX-RACCORDO	Pipe	Tuyau	Schlauch	Tubo	
	26	8000 A0671	1	Raccordo	Union	Raccord	Anschluss	Empalme	
	27	8000 99661	1	Tubo INFERIORE RAD. SX	Pipe	Tuyau	Schlauch	Tubo	

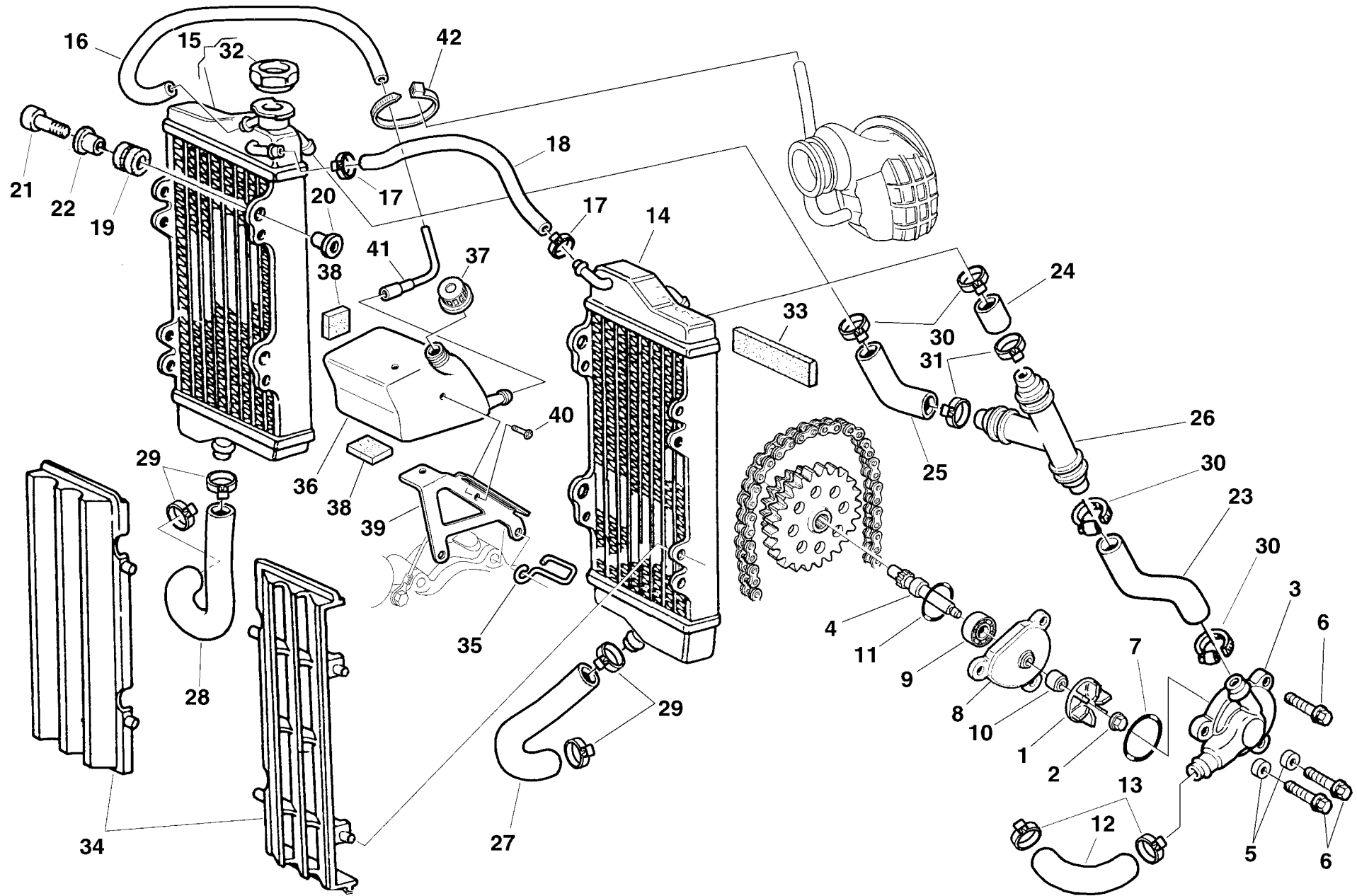

Note Notes Notas	Pos. No. N. Index Pos.	N. Cod. Code No. Nr. Code Code Nr N. Cod.	Q.tà Q.ty Q.te M.ge C.ad	DENOMINAZIONE	NAME	DESIGNATION	BESCHREIBUNG	DENOMINACION	Validità Validity Validité Gültig Validez
	28	8000 A0779	1	Tubo INFERIORE RAD. DX	Pipe	Tuyau	Schlauch	Tubo	
	29	8A00 99475	4	Fascetta	Clamp	Collier	Schelle	Banda	
	30	8B00 99475	3	Fascetta	Clamp	Collier	Schelle	Banda	
	31	8000 50453	3	Fascetta	Clamp	Collier	Schelle	Banda	
	32	8000 79077	1	Tappo	Plug	Bouchon	Verschluss	Tapón	
<b>WM</b>	33	8000 37140	1	Spessore elastico	Rubber spacer	Entretoise	Distanzstück	Espesor	
	34	8A00 A0872	2	Griglia	Grid	Grille	Rost	Parrilla	
	35	8000 86951	1	Occhiello sfciati (400)	Cable guide (400)	Guide cable (400)	Kabelführung (400)	Guia cable (400)	
<b>WM</b>	36	8000 96606	1	Serbatoio espansione	Tank	Réservoir	Tank	Depósito	
<b>WM</b>	37	8000 40427	1	Tappo	Plug	Bouchon	Verschluss	Tapón	
<b>WM</b>	38	8000 86004	2	Antivibrante	Silent-block	Antivibration	Schwingungsdämpfer	Anti-vibrador	
<b>WM</b>	39	8000 A4877	1	Piastrina	Plate	Plaqueette	Platte	Placa	
<b>WM</b>	40	8D00 67997	2	Vite	Screw	Vis	Schraube	Tornillo	
<b>WM</b>	41	8000 A1281	1	Tubazione	Hose	Tuyau	Schlauch	Tubo	
	42	8000 56444	1	Fascetta	Clamp	Collier	Schelle	Banda	

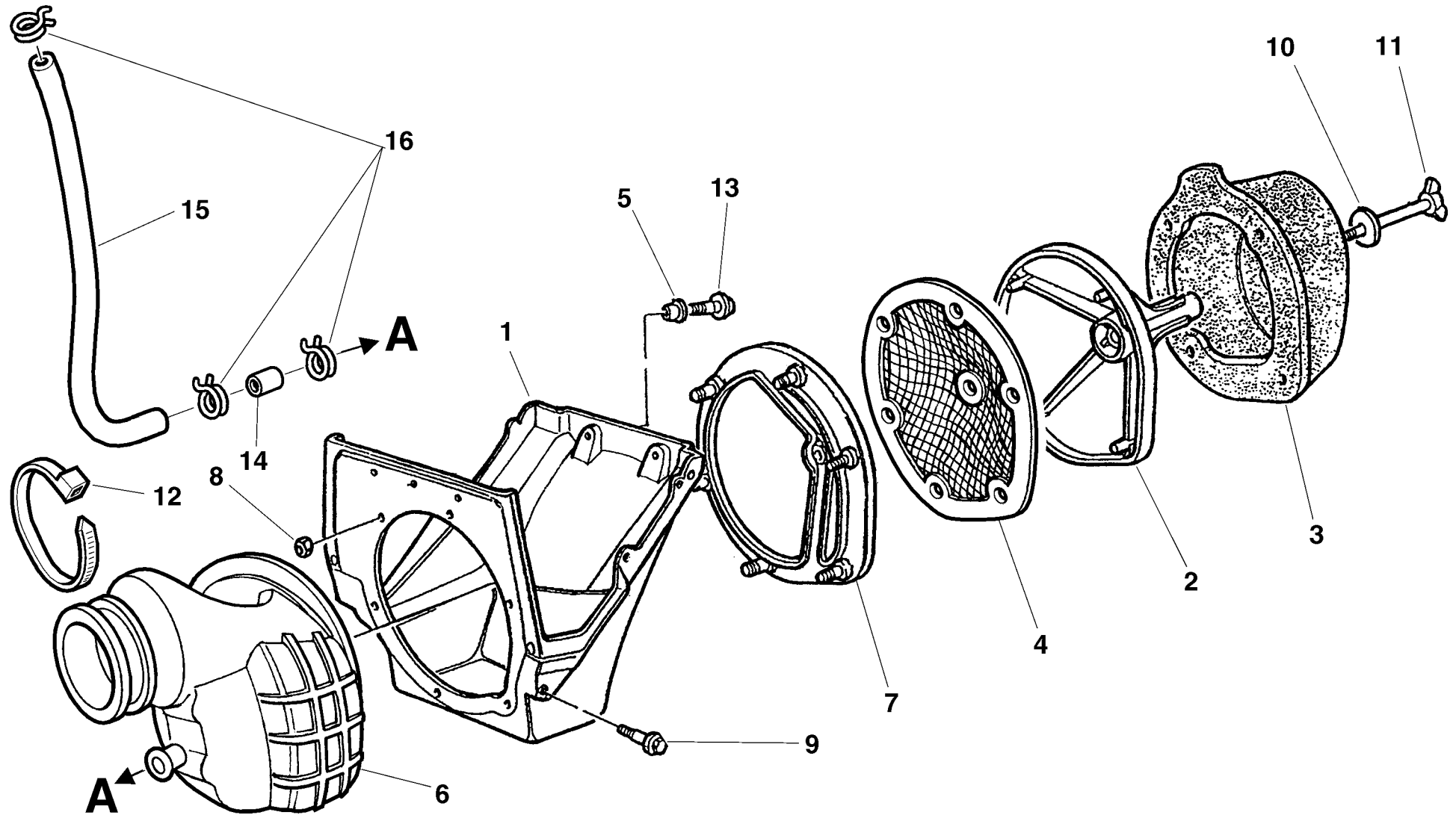



Note Notes Notas	Pos. No. Index Pos.	N. Cod. Code No. Nr. Code Code Nr N. Cod.	Q.tà Q.ty Q.te M.ge C.ad	DENOMINAZIONE	NAME	DESIGNATION	BESHREIBUNG	DENOMINACION	Validità Validity Validité Gültig Validez
	1	80A0 91792	1	Scatola filtro aria	Air filter box	Boîte filtre	Filterkasten	Caja filtro aire	
	2	8000 69549	1	Gabbia filtro	Cleaner cage	Cage pour filtre	Filterkafig	Caja filtro	
	3	8000 72641	1	Filtro aria	Air filter	Filtre à air	Luftfilter	Filtro aire	
	4	8000 A0656	1	Protezione antifiamma	Guard	Protection	Schutz	Protección	
	5	8000 69429	2	Bussola	Bushing	Duille	Buchse	Manguito	
	6	8000 A0681	1	Raccordo	Union	Raccord	Anschluss	Empalme	
	7	8000 70024	1	Flangia	Flange	Bride	Flansch	Brida	
	8	8000 40718	6	Dado	Nut	Ecrou	Mutter	Tuerca	
	9	8000 62726	2	Vite (M6x14 mm)	Screw (M6x14 mm)	Vis (M6x14 mm)	Schraube (M6x14 mm)	Tornillo (M6x14 mm)	
	10	62N1 15549	1	Rosetta piana	Washer	Rondelle	Scheibe	Arandela	
	11	8A00 37947	1	Vite	Screw	Vis	Schraube	Tornillo	
	12	8E00 99475	1	Fascetta	Clamp	Collier	Schelle	Banda	
	13	8000 62728	2	Vite (M6x20 mm)	Screw (M6x20 mm)	Vis (M6x20 mm)	Schraube (M6x20 mm)	Tornillo (M6x20 mm)	
	14	8000 A0900	1	Raccordo	Union	Raccord	Anschluss	Empalme	
	15	8A00 A0902	1	Tubetto sfiato (L=345 mm) (250)	Breather pipe (L=345 mm) (250)	Tuyau évent (L=345 mm) (250)	Entlüftungsrohr (L=345 mm) (250)	Tubo de purga (L=345 mm) (250)	
	15	8000 A0902	1	Tubetto sfiato (L=330 mm) (400-450-510)	Breather pipe (L=330 mm) (400-450-510)	Tuyau évent (L=330 mm) (400-450-510)	Entlüftungsrohr (L=330 mm) (400-450-510)	Tubo de purga (L=330 mm) (400-450-510)	
	16	8A00 95276	3	Fascetta	Clamp	Collier	Schelle	Banda	

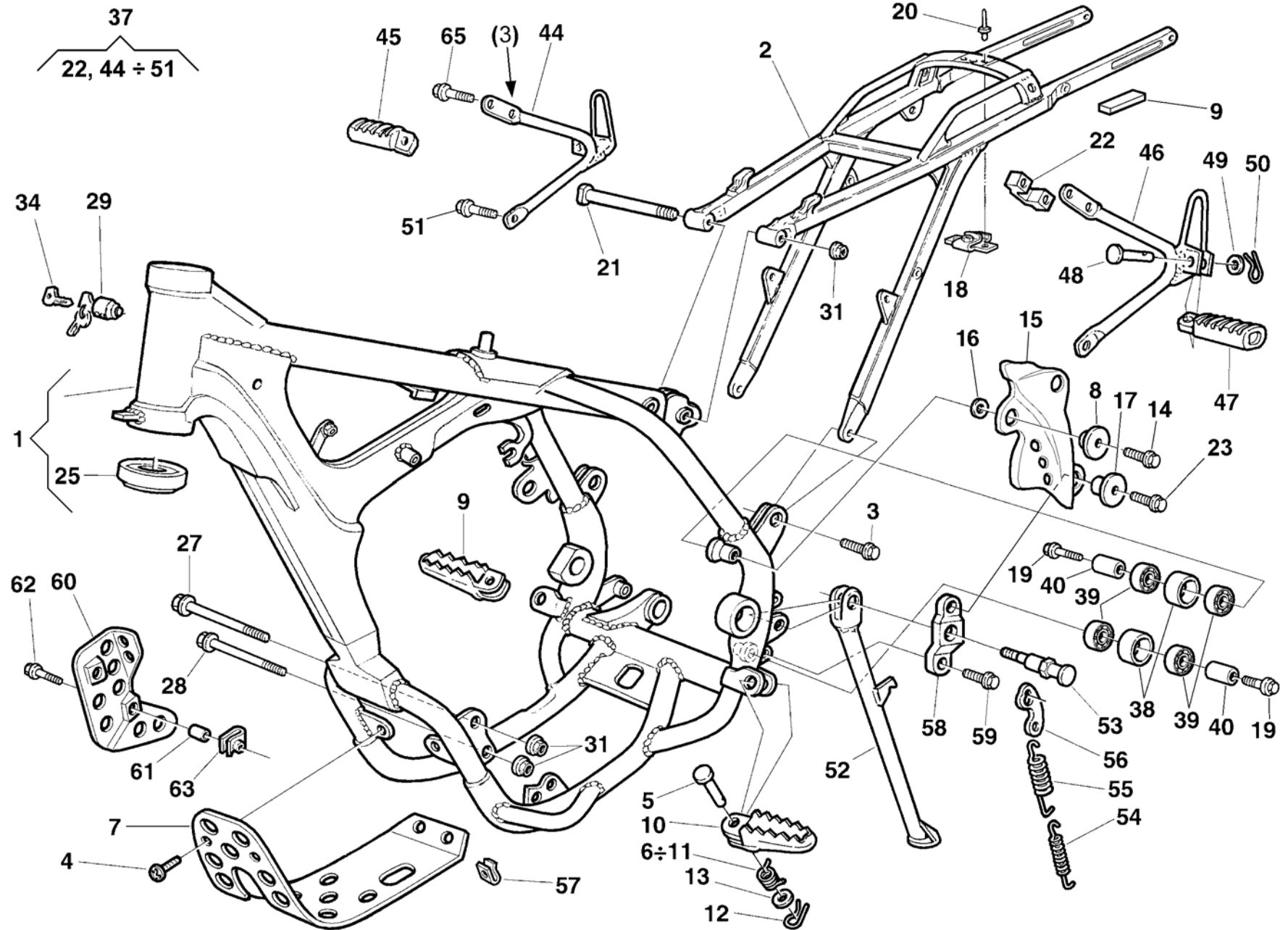

Note Notes Notas	Pos. No. N. Index Pos.	N. Cod. Code No. Nr. Code Code Nr N. Cod.	Q.tà Q.ty Q.te M.ge C.ad	DENOMINAZIONE	NAME	DESIGNATION	BESHREIBUNG	DENOMINACION	Validità Validity Validité Gültig Validez
	1	8AA0 99587	1	Telaio (TE)	Frame (TE)	Chassis (TE)	Rahmen (TE)	Bastidor (TE)	
	1	8EA0 99587	1	Telaio (TC)	Frame (TC)	Chassis (TC)	Rahmen (TC)	Bastidor (TC)	
	1	8R00 99587	1	Telaio (SMR)	Frame (SMR)	Chassis (SMR)	Rahmen (SMR)	Bastidor (SMR)	
	2	8000 A3104	1	Telaio posteriore	Rear frame	Chassis arrière	Sattelbrücke	Cuadro post.	
<b>WC</b>	3	8000 62732	2	Vite (M8x25 mm)	Screw (M8x25 mm)	Vis (M8x25 mm)	Schraube (M8x25 mm)	Tornillo (M8x25 mm)	
<b>M</b>	3	8000 69056	2	Vite (M8x20 mm)	Screw (M8x20 mm)	Vis (M8x20 mm)	Schraube (M8x20 mm)	Tornillo (M8x20 mm)	
<b>D</b>	4	8000 60898	4	Vite (M6x15 mm)	Screw (M6x15 mm)	Vis (M6x15 mm)	Schraube (M6x15 mm)	Tornillo (M6x15 mm)	
	5	8000 73140	2	Perno	Pin	Goupille	Stift	Clavija	
	6	8000 96907	1	Molla Sx	L.H. spring	Ressort G.	Feder L.	Resorte lz.	
<b>WCD</b>	7	8000 A0865	1	Paramotore	Engine guard	Garde moteur	Motorschutz	Para motor	
	8	8A00 66661	1	Distanziale	Spacer	Entretoise	Distanzstück	Separadòr	
	9	80A0 89953	1	Pedana destra	R.H. foot-rest	Repose-pieds D.	R. Fussraste	Pedal delnt. derech. compl.	
	10	80A0 89962	1	Pedana sinistra	L.H. foot-rest	Repose-pieds G.	L. Fussraste	Pedal delant. izrdo. compl.	
	11	8000 96908	1	Molla Dx	R.H. spring	Ressort D.	Feder R.	Resorte Der.	
	12	64N1 20068	2	Copiglia	Split pin	Goupille	Splint	Clavija	
	13	8A00 01815	2	Rosetta	Washer	Rondelle	Scheibe	Arandela	
<b>WC</b>	14	8B00 69056	1	Vite	Screw	Vis	Schraube	Tornillo	
<b>WC</b>	15	8000 A4395	1	Protezione telaio Sx	L.H. frame guard	Protection chassis G.	Rahmenschutz Links	Protección bastidor izquierda	
<b>WC</b>	16	8000 69429	1	Bussola	Bush	Douille	Buchse	Manguito	
<b>WC</b>	17	8A00 66661	1	Distanziale	Spacer	Entretoise	Distanzstück	Separadòr	
	18	8000 69150	1	Piastrina	Plate	Plaquette	Plättchen	Placa	
	19	8000 62796	2	Vite (M8x40 mm)	Screw (M8x40 mm)	Vis (M8x40 mm)	Schraube (M8x40 mm)	Tornillo (M8x40 mm)	
	20	8000 33373	2	Rivetto	Rivet	Rivet	Niet	Remache	
	21	8000 69111	1	Vite (M8x130 mm)	Screw (M8x130 mm)	Vis (M8x130 mm)	Schraube (M8x130 mm)	Tornillo (M8x130 mm)	
<b>DX</b>	22	8A00 71091	2	Cavallotto (TE, SMR)	U-bolt (TE, SMR)	Cavalier (TE, SMR)	Bügelbolzen (TE, SMR)	Caballate (TE, SMR)	
	23	8000 69056	1	Vite	Screw	Vis	Schraube	Tornillo	
<b>WM</b>	25	1513 07001	2	Cuscinetto (25-50-17,5)	Bearing (ø25xø50x17,5 mm)	Roulement (25-50-17,5)	Lager (ø25xø50x17,5 mm)	Cojinete (25-50-17,5)	
<b>C</b>	25	8000 87243	2	Cuscinetto (29-48-17,5)	Bearing (ø29xø48x17,5 mm)	Roulement (29-48-17,5)	Lager (ø29xø48x17,5 mm)	Cojinete (29-48-17,5)	
	27	8G00 73458	1	Perno (M8x150 mm)	Pin (M8x150 mm)	Pivot (M8x150 mm)	Bolzen (M8x150 mm)	Perno (M8x150 mm)	
	28	8G00 73458	1	Perno inf. fiss. motore M8-L150	Pin (M8x150 mm)	Pivot (M8x150 mm)	Bolzen (M8x150 mm)	Perno (M8x150 mm)	
<b>WM</b>	29	8000 43391	1	Serratura antifurto completa	Anti-left lock assy	Serrure anti-vol compl.	Sicherheitsschloss kpl.	Cerradura compl.	
	31	8000 43928	3	Dado	Nut	Ecrou	Mutter	Tuerca	
<b>WM</b>	34	8000 35531	1	Chiave grezza	Raw key	Clef primitive	Schlüssel	Llave	

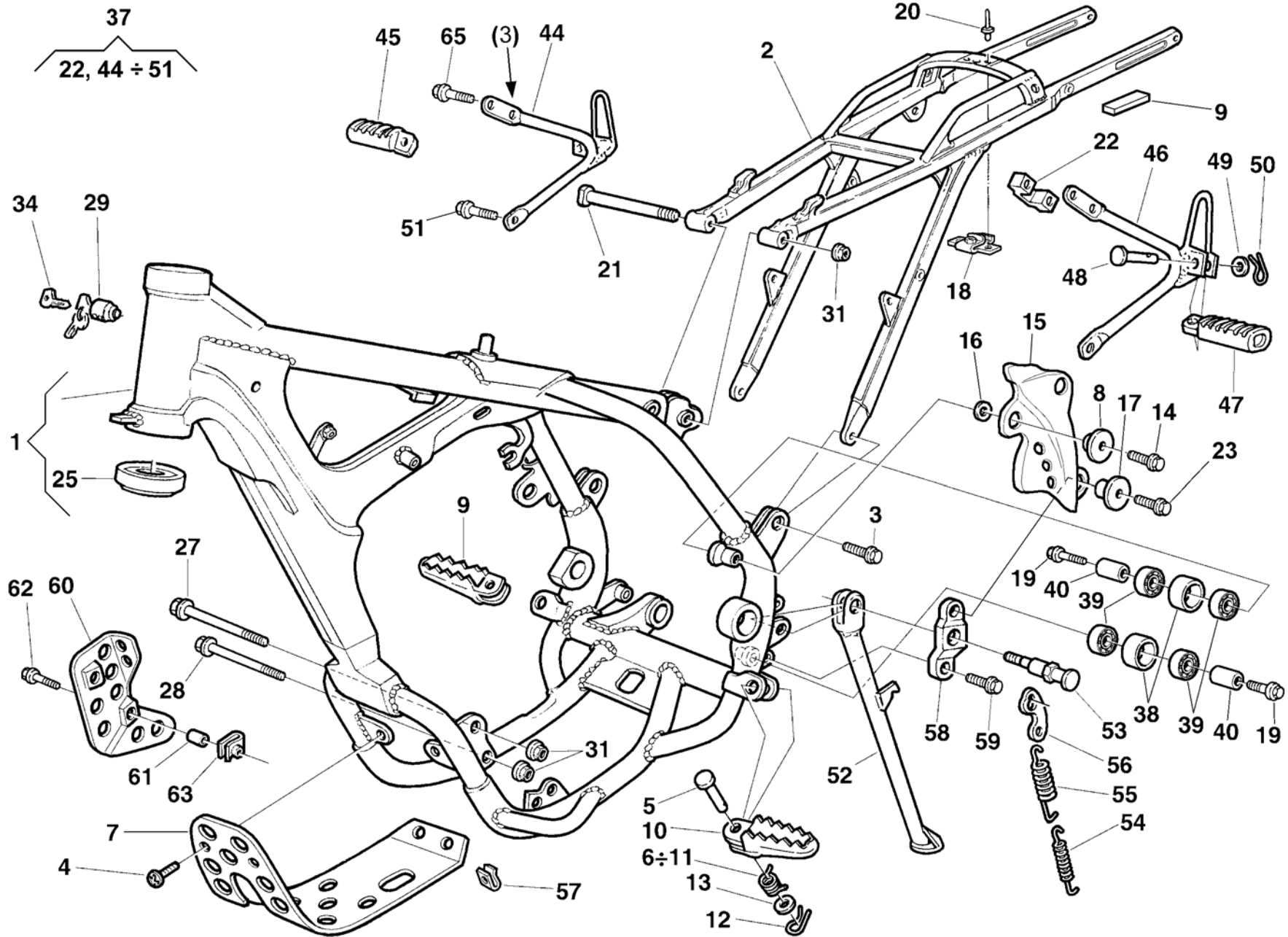

Note Notes Notas	Pos. No. N. Index Pos.	N. Cod. Code No. Nr. Code Code Nr N. Cod.	Q.tà Q.ty Q.te M.ge C.ad	DENOMINAZIONE	NAME	DESIGNATION	BESHREIBUNG	DENOMINACION	Validità Validity Validité Gültig Validez
<b>D</b>	37	8A00 A0677	1	Kit poggiapiedi (TE, SMR)	Compl. footrest Kit (TE, SMR)	Appui-pied complet (TE, SMR)	kpl. Fussraster-Kit (TE, SMR)	Kit apoyapiés (TE, SMR)	
	38	8A00 59433	2	Rullo catena	Roller	Aiguille	Rolle	Rodillo	
	39	8000 63312	4	Cuscinetto (ø8xØ22x7 mm)	Bearing (ø8xØ22x7 mm)	Roulement (ø8xØ22x7 mm)	Kugellager (ø8xØ22x7 mm)	Cojinete (ø8xØ22x7 mm)	
	40	8A00 59434	2	Distanziale	Spacer	Entretoise	Distanzstück	Separador	
<b>D</b>	44	80A0 A0676	1	Supporto Dx (TE, SMR)	R.H. support (TE, SMR)	Support D. (TE, SMR)	Halterung R. (TE, SMR)	Soporte der. (TE, SMR)	
<b>D</b>	45	8000 66652	1	Poggiapiedi passeggero Dx. (TE, SMR)	R.H. foot rest support (TE, SMR)	Support repose pied D. (TE, SMR)	R. Fussraster (TE, SMR)	Posapie der. (TE, SMR)	
<b>D</b>	46	80A0 A0675	1	Supporto Sx. (TE, SMR)	L.H. support (TE, SMR)	Support G. (TE, SMR)	Halterung L. (TE, SMR)	Soporte izq. (TE, SMR)	
<b>D</b>	47	8000 66651	1	Poggiapiedi passeggero Sx. (TE, SMR)	L.H. foot rest support (TE, SMR)	Support repose pied G. (TE, SMR)	L. Fussraster (TE, SMR)	Posapie izq. (TE, SMR)	
<b>D</b>	48	8000 41459	2	Perno (TE, SMR)	Pin (TE, SMR)	Pivot (TE, SMR)	Bolzen (TE, SMR)	Perno (TE, SMR)	
<b>D</b>	49	62N1 15504	2	Rosetta (TE, SMR)	Washer (TE, SMR)	Rondelle (TE, SMR)	Scheibe (TE, SMR)	Arandela (TE, SMR)	
<b>D</b>	50	64N1 20048	2	Copiglia (TE, SMR)	Split pin (TE, SMR)	Goupille (TE, SMR)	Splint (TE, SMR)	Clavija (TE, SMR)	
<b>D</b>	51	8000 62732	2	Vite M8-L25 (TE, SMR)	Screw M8-L25 (TE, SMR)	Vis M8-L25 (TE, SMR)	Schraube M8-L25 (TE, SMR)	Tornillo M8-L25 (TE, SMR)	
<b>WM</b>	52	80A0 A0264	1	Gamba laterale	Side stand	Bequille laterale	Seitenständer	Horquilla lateral	
<b>WM</b>	53	8000 A0266	1	Vite (M8x25 mm)	Screw (M8x25 mm)	Vis (M8x25 mm)	Schraube (M8x25 mm)	Tornillo (M8x25 mm)	
<b>WM</b>	54	8000 A0268	1	Molla interna	Spring	Ressort	Feder	Resorte	
<b>WM</b>	55	8000 A0269	1	Molla esterna	Spring	Ressort	Feder	Resorte	
<b>WM</b>	56	8000 A0267	1	Piastrina	Plate	Plaque	Platte	Plaque	
<b>D</b>	57	8000 46893	4	Dado (TC, TE)	Nut (TC, TE)	Ecrou (TC, TE)	Mutter (TC, TE)	Tuerca (TC, TE)	
<b>WM</b>	58	8000 99613	1	Piastrina	Plate	Plaque	Platte	Plaque	
<b>WM</b>	59	8000 69056	1	Vite (M7x16 mm)	Screw (M7x16 mm)	Vis (M7x16 mm)	Schraube (M7x16 mm)	Tornillo (M7x16 mm)	
<b>D</b>	60	8000 A1427	1	Protezione carter Dx (TC, TE)	R.h crankcase guard (TC, TE)	Protection carter D. (TC, TE)	Gehäusedeckelschutz Rechts (TC, TE)	Protección carter derecha (TC, TE)	
<b>D</b>	61	8A00 67207	2	Distanziale (TC, TE)	Spacer (TC, TE)	Entretoise (TC, TE)	Distanzstück (TC, TE)	Separador (TC, TE)	
<b>D</b>	62	8000 62730	2	Vite (TC, TE)	Screw (TC, TE)	Vis (TC, TE)	Schraube (TC, TE)	Tornillo (TC, TE)	
<b>D</b>	63	8000 46893	2	Dado (TC, TE)	Nut (TC, TE)	Ecrou (TC, TE)	Mutter (TC, TE)	Tuerca (TC, TE)	
<b>D</b>	65	8B00 69056	2	Vite M8x15 mm (TE, SMR)	Screw M8x15 mm (TE, SMR)	Vis M8x15 mm (TE, SMR)	Schraube M8-L15 (TE, SMR)	Tornillo M8x15 mm(TE, SMR)	



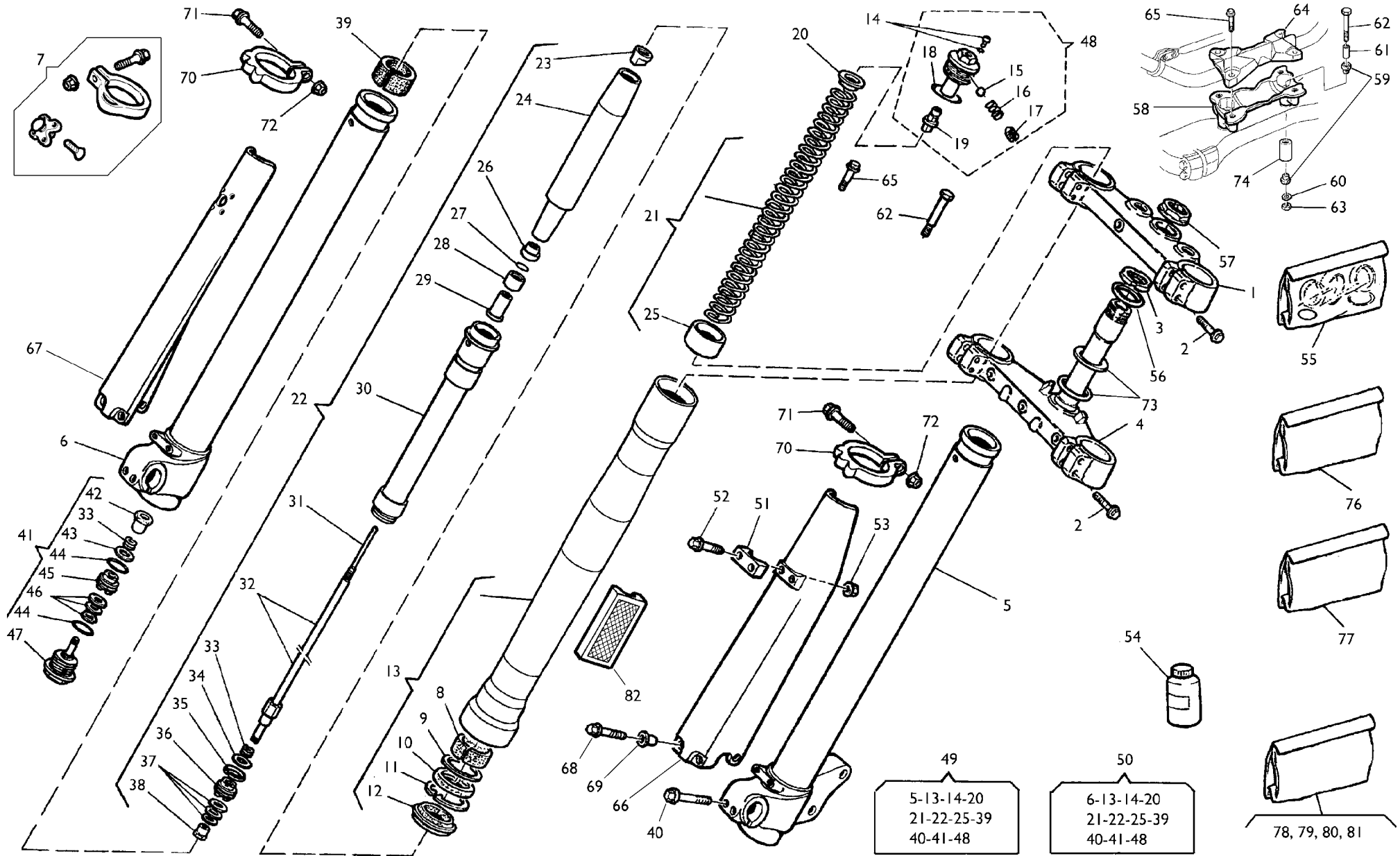



Note Notes Notas	Pos. No. N. Index Pos.	N. Cod. Code No. Nr. Code Code Nr N. Cod.	Q.tà Q.ty Q.te M.ge C.ad	DENOMINAZIONE	NAME	DESIGNATION	BESHREIBUNG	DENOMINACION	Validità Validity Validité Gültig Validez
	1	8A00 96811	1	Testa di sterzo (TE 250)	Steering head (TE 250)	Tête direction (TE 250)	Lenkkopf (TE 250)	Cabezal de dirección (TE 250)	
	1	8000 96811	1	Testa di sterzo (TC 250)	Steering head (TC 250)	Tête direction (TC 250)	Lenkkopf (TC 250)	Cabezal de dirección (TC 250)	
	2	8000 62796	8	Vite (M8x40 mm)	Screw (M8x40 mm)	Vis (M8x40 mm)	Schraube (M8x40 mm)	Tornillo (M8x40 mm)	
<b>W</b>	3	8000 83395	1	Ghiera registro cuscinetti	Ring nut	Embout	Nutmutter	Virol	
<b>C</b>	3	8A00 87717	1	Ghiera registro cuscinetti	Ring nut	Embout	Nutmutter	Virol	
<b>W</b>	4	8000 96897	1	Base di sterzo con perno	Steering crown with pin	Socle de direction avec pivot	Gabelbrücke mit Bolzen	Base de dirección con perno	
<b>C</b>	4	8000 96813	1	Base di sterzo con perno	Steering crown with pin	Socle de direction avec pivot	Gabelbrücke mit Bolzen	Base de dirección con perno	
	5	8000 98787	1	Stelo Sx. compl.	L.H. slider assy	Montant G. compl.	Bein, Kpl. L.	Deslizable izrda. compl.	
	6	8000 98786	1	Stelo Dx. compl.	R.H. slider assy	Montant D. compl.	Bein, Kpl. R.	Deslizable der. compl.	
<b>DC</b>	7	8000 A3191	1	Kit gancio partenza	Kit starting hook	Kit crochet pour départ	Abfahrthacken	Gancho por salida	
<b>N</b>	8	(a), (b)	2	Bussola	Bushing	Douille	Buchse	Manguito	
<b>N</b>	9		2	Scodellino	Cup	Cuvette	Teller	Cubeta	
<b>N</b>	10	(a), (c)	2	Anello di tenuta	Seal ring	Bague de retenue	Dichtring	Anillo de retención	
<b>N</b>	11	(c)	2	Anello di fermo	Stop ring	Bague d'arrêt	Haltering	Anillo de retención	
<b>N</b>	12	(a), (c)	2	Raschiapolvere	Dust scraper	Racloir poudre	Pulverabschaber	Rascador de polvo	
	13	8000 91474	2	Portastelo completo	Pipe assy	Groupe tuyau compl.	Rohrgruppe Kpl	Grupo tubo compl.	
<b>N</b>	14		2	Vite	Screw	Vis	Schraube	Tornillo	
<b>N</b>	15		2	Sfera	Ball	Bille	Kugel	Esfera	
<b>N</b>	16		2	Molla per sfera	Spring	Ressort	Feder	Resorte	
<b>N</b>	17		2	Grano filettato	Dowel	Grain	Stift	Pasadør	
<b>N</b>	18	(a)	2	Anello OR	O-Ring	Bague OR	O-Ring	Anillo OR	
	19	8000 91479	2	Gruppo registro	Adjuster set	Groupe réglage	Reglergruppe	Grupo regulaciòn	
	20	8000 77373	2	Scodellino	Cup	Cuvette	Teller	Cubeta	
	21	8000 98789	1	Kit molla k=4,8 N/mm	Spring k=4,8 N/mm	Ressort k=4,8 N/mm	Feder k=4,8 N/mm	Resorte k=4,8 N/mm	
<b>W</b>	22	8000 98552	2	Gruppo pompante compl.	Damping element compl.	Amortissement compl.	Schwingungsdämpfer Kpl.	Bombedadora compl.	
<b>C</b>	22	8000 98792	2	Gruppo pompante compl.	Damping element compl.	Amortissement compl.	Schwingungsdämpfer Kpl.	Bombedadora compl.	
<b>N</b>	23		2	Dado	Nut	Ecrou	Mutter	Tuerca	
<b>N</b>	24		2	Guidamolla	Spring guide	Guide ressort	Federführung	Guia resorte	
<b>N</b>	25		2	Tubetto	Pipe	Tuyau	Rohr	Tubo	
<b>N</b>	26		2	Dado	Nut	Ecrou	Mutter	Tuerca	
<b>N</b>	27		2	Anello SEEGER	SEEGER ring	Anneau SEEGER	SEEGER Ring	Anillo SEEGER	
<b>N</b>	28		2	Tampone di fondo	Pad	Tampon	Stopfen	Tampòn	
<b>N</b>	29		2	Distanziale	Spacer	Entretoise	Distanzstück	Separadør	

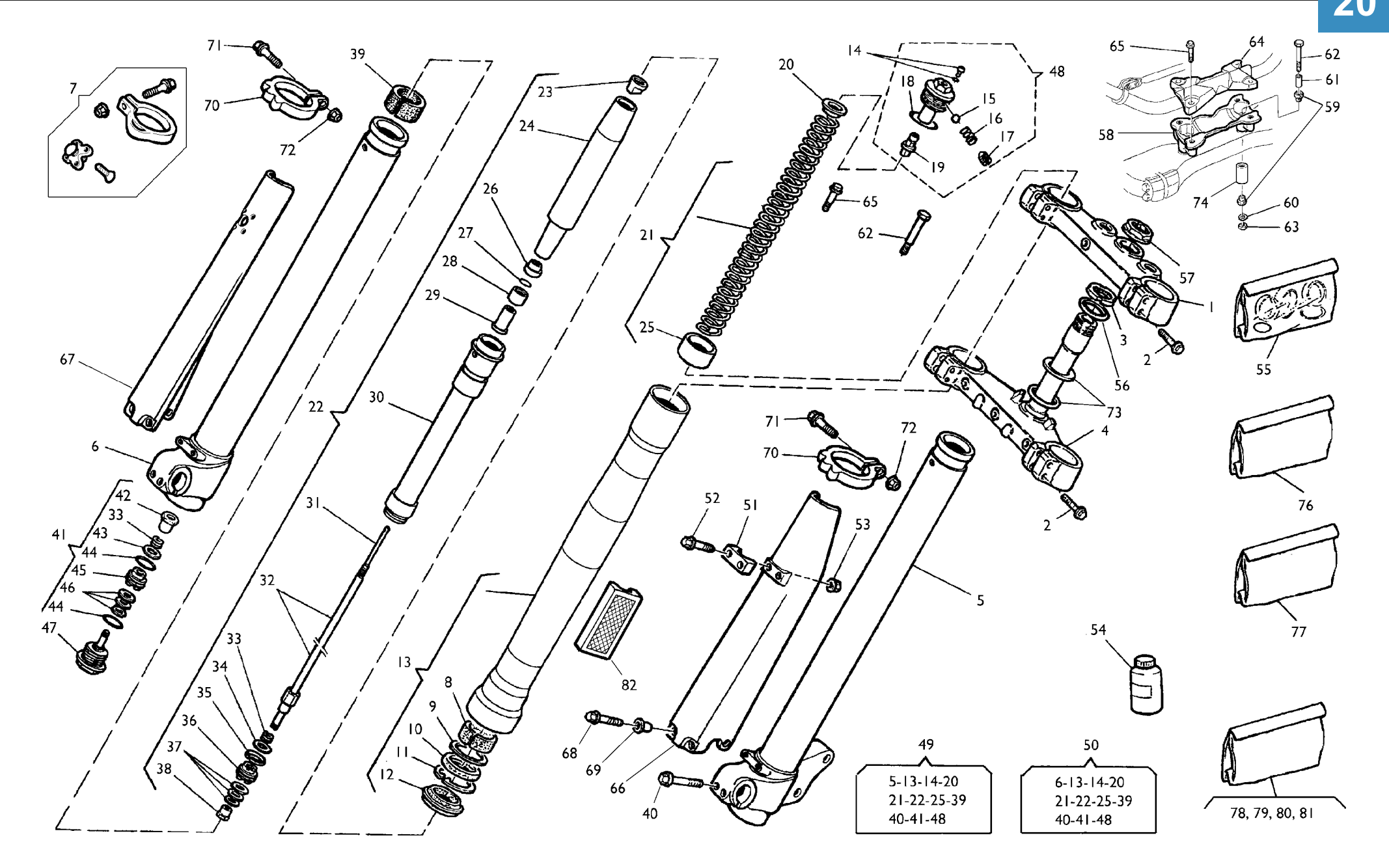

49  
5-13-14-20  
21-22-25-39  
40-41-48

50  
6-13-14-20  
21-22-25-39  
40-41-48

78, 79, 80, 81

Note Notes Notas	Pos. No. N. Index Pos.	N. Cod. Code No. Nr. Code Code Nr N. Cod.	Q.tà Q.ty Q.te M.ge C.ad	DENOMINAZIONE	NAME	DESIGNATION	BESHREIBUNG	DENOMINACION	Validità Validity Validité Gültig Validez
<b>N</b>	30		2	Custodia	Housung	Cage	Korb	Custodia	
<b>N</b>	31		2	Asta interna	Internal rod	Barre	Stange	Varilla	
<b>N</b>	32		2	Ass. asta	Rod assy	Barre compl.	Stange Kpl	Grupo varilla	
<b>N</b>	33		4	Molla	Spring	Ressort	Feder	Resorte	
<b>N</b>	34	(d)	2	Lamella	Plate	Lamelle	Plättchen	Laminilla	
<b>N</b>	35	(a)	2	Segmento	Circlip	Segment	Colbenring	Segmento	
<b>N</b>	36		2	Pistone estensione	R.H. piston	Piston D.	Kolbe R.	Pistón der.	
<b>N</b>	37	(d)	6	Lamella	Plate	Lamelle	Plättchen	Laminilla	
<b>N</b>	38		2	Dado	Nut	Ecrou	Mutter	Tueca	
<b>N</b>	39	(a), (b)	2	Bussola	Bushing	Douille	Buchse	Manguito	
	40	8000 62729	4	Vite (M6x25 mm)	Screw (M6x25 mm)	Vis (M6x25 mm)	Schraube (M6x25 mm)	Tornillo (M6x25 mm)	
<b>W</b>	41	8000 A6179	2	Ass. valvola di fondo	Valve	Soupape	Ventil	Válvula	
<b>C</b>	41	8000 95260	2	Ass. valvola di fondo	Valve	Soupape	Ventil	Válvula	
<b>N</b>	42		2	Dado	Nut	Ecrou	Mutter	Tuerca	
<b>N</b>	43	(d)	2	Lamella	Plate	Lamelle	Plättchen	Laminilla	
<b>N</b>	44	(a)	2	Anello OR	O-Ring	Bague OR	O-Ring	Anillo OR	
<b>N</b>	45		2	Pistone compressione	Piston	Piston	Kolbe	Pistón	
<b>N</b>	46	(d)	6	Lamella	Plate	Lamelle	Plättchen	Laminilla	
<b>N</b>	47		2	Valvola	Valve	Soupape	Ventil	Valvula	
<b>N</b>	48	8000 91480	2	Gruppo tappo	Plug assy	Groupe bouchon	Verschlussgruppe Kpl	Grupo tapón	
<b>W</b>	49	8A00 97015	1	Gamba Sx. compl.	L.H. fork leg assy	Fourche complete G.	Telegabel Kpl. L.	Horquilla izrda. compl.	
<b>C</b>	49	8000 A5947	1	Gamba Sx. compl.	L.H. fork leg assy	Fourche complete G.	Telegabel Kpl. L.	Horquilla izrda. compl.	
<b>W</b>	50	8A00 97016	1	Gamba Dx. compl.	R.H. fork leg assy	Fourche complete D.	Telegabel Kpl. R.	Horquilla derech. compl.	
<b>C</b>	50	8000 A5946	1	Gamba Dx. compl.	R.H. fork leg assy	Fourche complete D.	Telegabel Kpl. R.	Horquilla derech. compl.	
<b>WC</b>	51	8000 A0633	1	Piastrina (codice colore E) <b>BLU</b>	Plate (color code E) <b>BLUE</b>	Plaque (code couleur E) <b>BLEU</b>	Plättchen (Code Farbe E) <b>BLAU</b>	Placa (código color E) <b>AZÚL</b>	
	52	8A00 67997	2	Vite	Screw	Vis	Schraube	Tornillo	
	53	8000 61355	2	Dado	Nut	Ecrou	Mutter	Tueca	
<b>R</b>	54	8000 80260	1	Olio forcella	Front fork oil	Huile fourche avant	Öl für die Vordergabel	Aceite horquilladelantera	
<b>W</b>	55	8000 91519	1	Gruppo guarnizioni	Gasket set	Groupe garnitures	Dichtungssatz	Grupo juntas	
<b>W</b>	56	8A00 65503	2	Rosetta piana	Washer	Rondelle	Scheibe	Arandela	
<b>C</b>	56	8000 87736	2	Rosetta piana	Washer	Rondelle	Scheibe	Arandela	
<b>W</b>	57	8000 69315	1	Dado	Nut	Ecrou	Mutter	Tuerca	

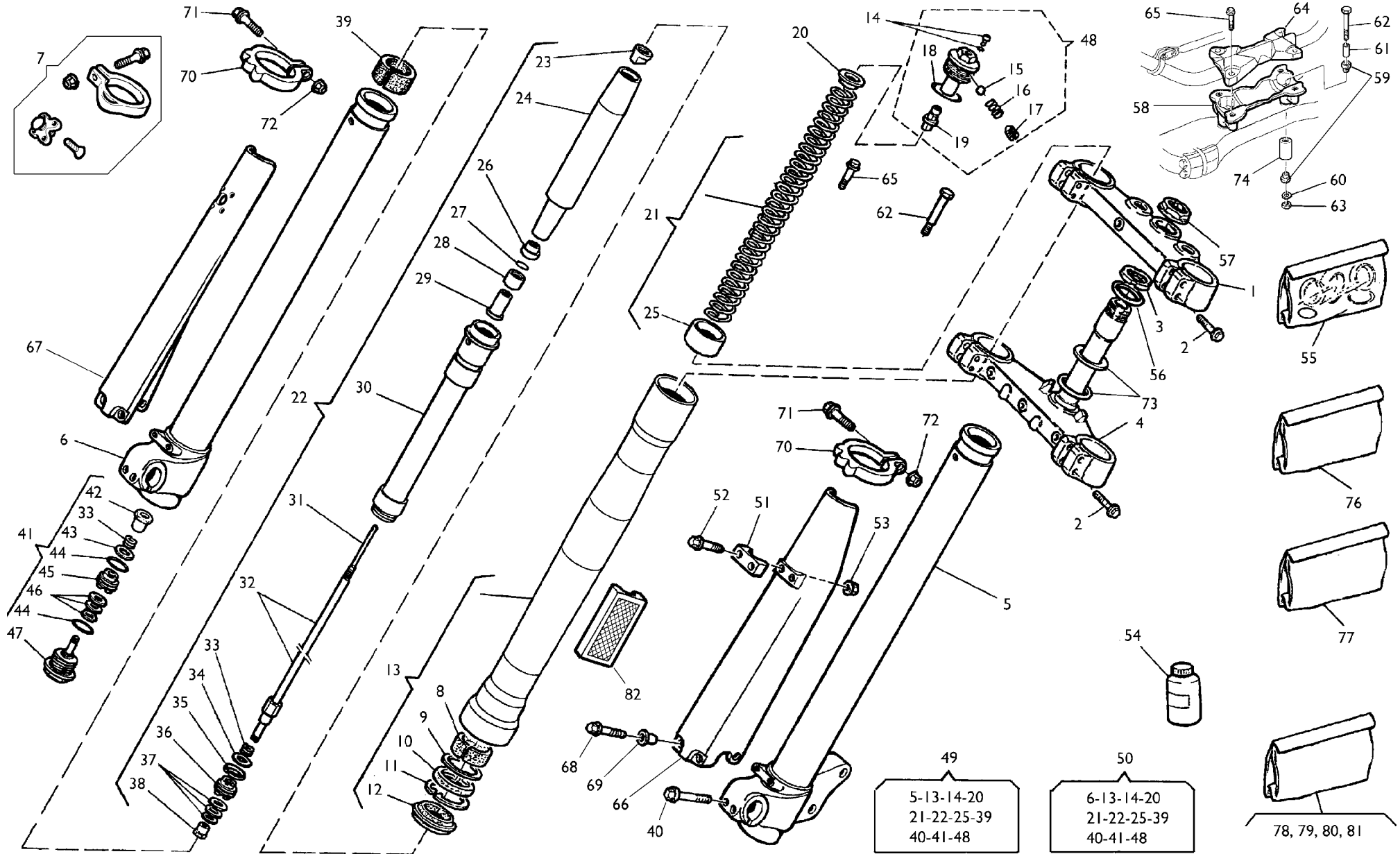

Note Notes Notas	Pos. No. Index Pos.	N. Cod. Code No. Nr. Code Code Nr N. Cod.	Q.tà Q.ty Q.te M.ge C.ad	DENOMINAZIONE	NAME	DESIGNATION	BESHREIBUNG	DENOMINACION	Validità Validity Validité Gültig Validez
C	57	8A00 69315	1	Dado	Nut	Ecrou	Mutter	Tuerca	
W	58	8000 98237	1	Mozzetto inferiore	Hub	Moyeau	Radnabe	Cbo	
C	58	8000 A6069	1	Mozzetto inferiore	Hub	Moyeau	Radnabe	Cbo	
	59	8000 60233	4	Gommino	Rubber pad	Pièce caoutchouc	Gummstück	Junta de goma	
	60	8000 60234	2	Rosetta piana	Washer	Rondelle	Scheibe	Arandela	
	61	8000 53155	2	Distanziale	Spacer	Entretoise	Distanzstück	Separador	
W	62	60N1 01223	2	Vite (M10x85 mm)	Screw(M10x85 mm)	Vis(M10x85 mm)	Schraube(M10x85 mm)	Tornillo(M10x85 mm)	
C	62	60N1 01222	2	Vite (M10x80 mm)	Screw(M10x80 mm)	Vis(M10x80 mm)	Schraube(M10x80 mm)	Tornillo(M10x80 mm)	
	63	8000 61314	2	Dado	Nut	Ecrou	Mutter	Tuerca	
W	64	8000 98118	2	Mozzetto superiore	Hub	Moyeau	Radnabe	Cubo	
C	64	8000 A6068	2	Mozzetto superiore	Hub	Moyeau	Radnabe	Cubo	
	65	8C00 69056	4	Vite (M8x30 mm)	Screw (M8x30 mm)	Vis (M8x30 mm)	Schraube (M8x30 mm)	Tornillo (M8x30 mm)	
W	66	80G0 69337	1	Protezione steli Sx. (codice colore E) <b>BLU</b>	Guard L.H. (color code E) <b>BLUE</b>	Protection D. (code couleur E) <b>BLEU</b>	Schutz L. (Code Farbe E) <b>BLAU</b>	Protección izq. (còdigo colòr E) <b>AZÚL</b>	
C	66	80C0 69337	1	Protezione steli Sx. (codice colore G) <b>NERO</b>	Guard L.H. (color code E) <b>BLACK</b>	Protection D. (code couleur E) <b>NOIR</b>	Schutz L. (Code Farbe E) <b>SCHWARZ</b>	Protección izq. (còdigo colòr E) <b>NEGRO</b>	
W	67	80G0 69338	1	Protezione steli Dx. (codice colore E) <b>BLU</b>	Guard R.H. (color code E) <b>BLUE</b>	Protection G. (code couleur E) <b>BLEU</b>	Schutz R. (Code Farbe E) <b>BLAU</b>	Protección der. (còdigo colòr E) <b>AZÚL</b>	
C	67	80C0 69338	1	Protezione steli Dx. (codice colore G) <b>NERO</b>	Guard R.H. (color code E) <b>BLACK</b>	Protection G. (code couleur E) <b>NOIR</b>	Schutz R. (Code Farbe E) <b>SCHWARZ</b>	Protección der. (còdigo colòr E) <b>NEGRO</b>	
	68	8000 67997	6	Vite	Screw	Vis	Schraube	Tornillo	
	69	8000 69282	6	Bussola	Bush	Douille	Buchse	Manguito	
	70	8000 93283	2	Anello	Ring	Bague	Ring	Anilo	
W	71	8B00 66525	2	Vite	Screw	Vis	Schraube	Tornillo	
C	71	8B00 67997	2	Vite	Screw	Vis	Schraube	Tornillo	
	72	8000 56443	2	Dado	Nut	Ecrou	Mutter	Tuerca	
C	73	8000 87745	2	Guarnizione di tenuta	Gasket	Garniture	Dichtung	Guarnición	
C	74	8000 A6746	2	Distanziale	Spacer	Entretoise	Distanzstück	Separador	
	76	8000 97750	1	Kit boccole	Bush kit	Kit douille	Buchsekit	Kit manguito	
	77	8000 97749	1	Kit anelli di tenuta	Seal ring kit	Kit bague de retenue	Dichtringkit	Kit anillo de retención	
	78	8000 98782	1	Kit lamelle (0,1 mm)	Plate kit (0,1 mm)	Kit lamelle (0,1 mm)	Plättchenkit (0,1 mm)	Kit Laminilla (0,1 mm)	
	79	8000 98783	1	Kit lamelle (0,2 mm)	Plate kit (0,2 mm)	Kit lamelle (0,2 mm)	Plättchenkit (0,2 mm)	Kit Laminilla (0,2 mm)	
	80	8000 98784	1	Kit lamelle (0,3 mm)	Plate kit (0,3 mm)	Kit lamelle (0,3 mm)	Plättchenkit (0,3 mm)	Kit Laminilla (0,3 mm)	

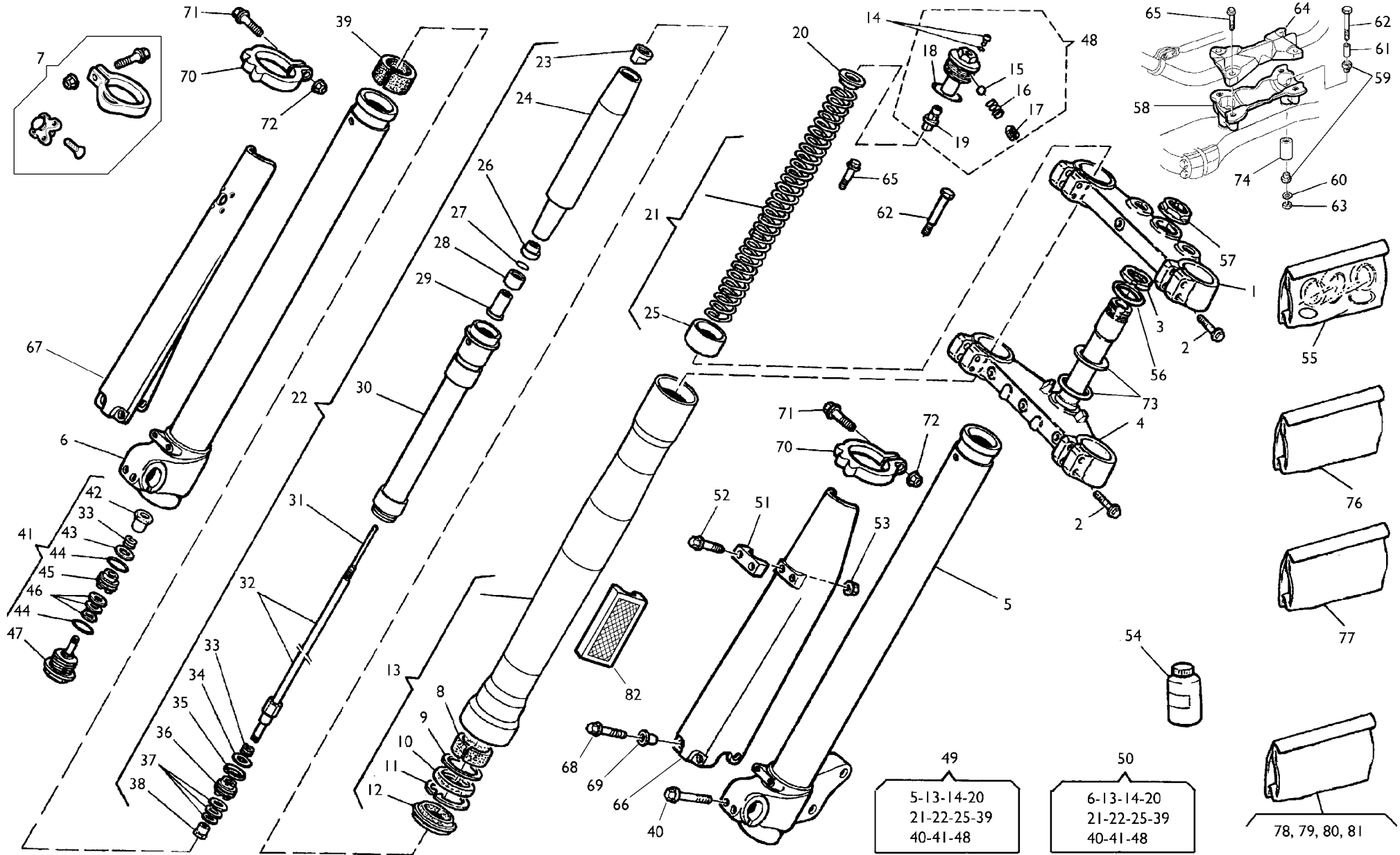





TC-TE 250 / 2006

TAVOLA  
DRAWING  
TABLE  
BILD  
TABLA

20

SOSPENSIONE ANTERIORE - FRONT FORK ASSEMBLY  
SUSPENSION AVANT - VORDERTELESKOPGABEL  
SUSPENSION DELANTERA

Note Notes Marke Notas	Pos. No. Index Pos.	N. Cod. Code No. Nr. Code Code Nr N. Cod.	Q.tà Q.ty Q.te M.ge C.ad	DENOMINAZIONE	NAME	DESIGNATION	BESHREIBUNG	DENOMINACION	Validità Validity Validité Gültig Validez
	81	8000 98785	1	Kit lamelle (0,4 mm)	Plate kit (0,4 mm)	Kit lamelle (0,4 mm)	Plättchenkit (0,4 mm)	Kit Laminilla (0,4 mm)	
Y	82	8000 74842	2	Catadiottro ambra (AUS)	Reflector amber (AUS)	Catadioptrique ambre (AUS)	Rückstrahler Amber (AUS)	Catafaros àmbar (AUS)	
CU	82	8000 74842	2	Catadiottro ambra (CDN)	Reflector amber (CDN)	Catadioptrique ambre (CDN)	Rückstrahler Amber (CDN)	Catafaros àmbar (CDN)	
a				Forniti anche in gruppo pos. 55	Supplied in bag ref. N° 55	Son fournies en unités pos. 55	Sind im Umschlag Bez. Nr 55	Provisto en grupo pos. 55	
b				Forniti anche in gruppo pos. 76	Supplied in bag ref. N° 76	Son fournies en unités pos. 76	Sind im Umschlag Bez. Nr 76	Provisto en grupo pos. 76	
c				Forniti anche in gruppo pos. 77	Supplied in bag ref. N° 77	Son fournies en unités pos. 77	Sind im Umschlag Bez. Nr 77	Provisto en grupo pos. 77	
d				Forniti anche in gruppo pos. 78, 79, 80, 81	Supplied in bag ref. N° 78, 79, 80, 81	Son fournies en unités pos. 78, 79, 80, 81	Sind im Umschlag Bez. Nr 78, 79, 80, 81	Provisto en grupo pos. 78, 79, 80, 81	

**DA DEFINIRE**

Note Notes Notas	Pos. No. N. Index Pos.	N. Cod. Code No. Nr. Code Code Nr N. Cod.	Q.tà Q.ty Q.te M.ge C.ad	DENOMINAZIONE	NAME	DESIGNATION	BESHREIBUNG	DENOMINACION	Validità Validity Validité Gültig Validez
	1	8A00 A5961	1	Testa di sterzo (TE 450-510)	Steering head (TE 450-510)	Tête direction (TE 450-510)	Lenkkopf (TE 450-510)	Cabezal de dirección (TE 450-510)	
	1	8000 A5961	1	Testa di sterzo (TC 450-510)	Steering head (TC 450-510)	Tête direction (TC 450-510)	Lenkkopf (TC 450-510)	Cabezal de dirección (TC 450-510)	
	1	8B00 A5961	1	Testa di sterzo (SMR)	Steering head (SMR)	Tête direction (SMR)	Lenkkopf (SMR)	Cabezal de dirección (SMR)	
<b>WM</b>	2	8000 62796	4	Vite (M8x40 mm)	Screw (M8x40 mm)	Vis (M8x40 mm)	Schraube (M8x40 mm)	Tornillo (M8x40 mm)	
<b>C</b>	3	8000 83395	1	Ghiera registro cuscinetti	Ring nut	Embout	Nutmutter	Virol	
	3	8A00 87717	1	Ghiera registro cuscinetti	Ring nut	Embout	Nutmutter	Virol	
	4	8000 A6010	1	Base di sterzo con perno (TE 450-510)	Steering crown with pin (TE 450-510)	Socle de direction avec pivot (TE 450-510)	Gabelbrücke mit Bolzen (TE 450-510)	Base de dirección con perno (TE 450-510)	
	4	8000 A5963	1	Base di sterzo con perno (TC 450-510)	Steering crown with pin (TC 450-510)	Socle de direction avec pivot (TC 450-510)	Gabelbrücke mit Bolzen (TC 450-510)	Base de dirección con perno (TC 450-510)	
<b>M</b>	4	8A00 A6010	1	Base di sterzo con perno	Steering crown with pin	Socle de direction avec pivot	Gabelbrücke mit Bolzen	Base de dirección con perno	
<b>WC</b>	5	8000 98787	1	Stelo Sx. compl.	L.H. slider assy	Montant G. compl.	Bein, Kpl. L.	Deslizable izrda. compl.	
<b>E&amp;M</b>	5	8000 96643	1	Stelo Sx. compl.	L.H. slider assy	Montant G. compl.	Bein, Kpl. L.	Deslizable izrda. compl.	
<b>M</b>	5	8A00 96643	1	Stelo Sx. compl.	L.H. slider assy	Montant G. compl.	Bein, Kpl. L.	Deslizable izrda. compl.	
	6	8000 98786	1	Stelo Dx. compl.	R.H. slider assy	Montant D. compl.	Bein, Kpl. R.	Deslizable der. compl.	
<b>DC</b>	7	8000 A6641	1	Kit gancio partenza	Kit starting hook	Kit crochet pour départ	Abfahrthacken	Gancho por salida	
<b>N</b>	8	(a), (b)	2	Bussola	Bushing	Douille	Buchse	Manguito	
<b>N</b>	9		2	Scodellino	Cup	Cuvette	Teller	Cubeta	
<b>N</b>	10	(a), (c)	2	Anello di tenuta	Seal ring	Bague de retenue	Dichtring	Anillo de retención	
<b>N</b>	11	(c)	2	Anello di fermo	Stop ring	Bague d'arrêt	Haltering	Anillo de retención	
<b>N</b>	12	(a), (c)	2	Raschiapolvere	Dust scraper	Racloir poudre	Pulverabschaber	Rascador de polvo	
	13	8000 91474	2	Portastelo completo	Pipe assy	Groupe tuyau compl.	Rohrgruppe Kpl	Grupo tubo compl.	
<b>N</b>	14		2	Vite	Screw	Vis	Schraube	Tornillo	
<b>N</b>	15		2	Sfera	Ball	Bille	Kugel	Esfera	
<b>N</b>	16		2	Molla per sfera	Spring	Ressort	Feder	Resorte	
<b>N</b>	17		2	Grano filettato	Dowel	Grain	Stift	Pasadòr	
<b>N</b>	18	(a)	2	Anello OR	O-Ring	Bague OR	O-Ring	Anillo OR	
	19	8000 91479	2	Gruppo registro	Adjuster set	Groupe réglage	Reglergruppe	Grupo regulaciòn	
	20	8000 77373	2	Scodellino	Cup	Cuvette	Teller	Cubeta	
<b>WC</b>	21	8000 98789	1	Kit molla k=4,8 N/mm	Spring k=4,8 N/mm	Ressort k=4,8 N/mm	Feder k=4,8 N/mm	Resorte k=4,8 N/mm	
<b>M</b>	21	8000 98803	1	Kit molla k=5,0 N/mm	Spring k=5,0 N/mm	Ressort k=5,0 N/mm	Feder k=5,0 N/mm	Resorte k=5,0 N/mm	

**DA DEFINIRE**

**DA DEFINIRE**

Note Notes Notas	Pos. No. Index Pos.	N. Cod. Code No. Nr. Code Code Nr N. Cod.	Q.tà Q.ty Q.te M.ge C.ad	DENOMINAZIONE	NAME	DESIGNATION	BESHREIBUNG	DENOMINACION	Validità Validity Validité Gültig Validez
<b>W</b>	22	8000 98552	2	Gruppo pompante compl.	Damping element compl.	Amortissement compl.	Schwingungsdämpfer Kpl.	Bombedora compl.	
<b>C</b>	22	8000 98792	2	Gruppo pompante compl.	Damping element compl.	Amortissement compl.	Schwingungsdämpfer Kpl.	Bombedora compl.	
<b>M</b>	22	8000 96645	2	Gruppo pompante compl.	Damping element compl.	Amortissement compl.	Schwingungsdämpfer Kpl.	Bombedora compl.	
<b>N</b>	23		2	Dado	Nut	Ecrou	Mutter	Tuerca	
<b>N</b>	24		2	Guidamolla	Spring guide	Guide ressort	Federführung	Guia resorte	
<b>N</b>	25		2	Tubetto	Pipe	Tuyau	Rohr	Tubo	
<b>N</b>	26		2	Dado	Nut	Ecrou	Mutter	Tuerca	
<b>N</b>	27		2	Anello SEEGER	SEEGER ring	Anneau SEEGER	SEEGER Ring	Anillo SEEGER	
<b>N</b>	28		2	Tampone di fondo	Pad	Tampon	Stopfen	Tampòn	
<b>N</b>	29		2	Distanziale	Spacer	Entretoise	Distanzstück	Separador	
<b>N</b>	30		2	Custodia	Housing	Cage	Korb	Custodia	
<b>N</b>	31		2	Asta interna	Internal rod	Barre	Stange	Varilla	
<b>N</b>	32		2	Ass. asta	Rod ass	Rod compl.	Rod compl. Kpl	Grupo varilla	
<b>N</b>	33		4	Molla	Spring	Ressort	Feder	Resorte	
<b>N</b>	34	(d)	2	Lamella	Plate	Lamelle	Plättchen	Laminilla	
<b>N</b>	35	(a)	2	Segmento	Circlip	Segment	Colbenring	Segmento	
<b>N</b>	36		2	Pistone estensione	R.H. piston	Piston D.	Kolbe R.	Pistón der.	
<b>N</b>	37	(d)	6	Lamella	Plate	Lamelle	Plättchen	Laminilla	
<b>N</b>	38		2	Dado	Nut	Ecrou	Mutter	Tueca	
<b>N</b>	39	(a), (b)	2	Bussola	Bushing	Douille	Buchse	Manguito	
	40	8000 62729	4	Vite (M6x25 mm)	Screw (M6x25 mm)	Vis (M6x25 mm)	Schraube (M6x25 mm)	Tornillo (M6x25 mm)	
<b>W</b>	41	8000 98781	2	Ass. valvola di fondo	Valve	Soupape	Ventil	Válvula	
<b>C</b>	41	8000 95260	2	Ass. valvola di fondo	Valve	Soupape	Ventil	Válvula	
<b>M</b>	41	8000 96647	2	Ass. valvola di fondo	Valve	Soupape	Ventil	Válvula	
<b>N</b>	42		2	Dado	Nut	Ecrou	Mutter	Tuerca	
<b>N</b>	43	(d)	2	Lamella	Plate	Lamelle	Plättchen	Laminilla	
<b>N</b>	44	(a)	2	Anello OR	O-Ring	Bague OR	O-Ring	Anillo OR	
<b>N</b>	45		2	Pistone compressione	Piston	Piston	Kolbe	Pistón	
<b>N</b>	46	(d)	6	Lamella	Plate	Lamelle	Plättchen	Laminilla	
<b>N</b>	47		2	Valvola	Valve	Soupape	Ventil	Valvula	
<b>N</b>	48	8000 91480	2	Gruppo tappo	Plug assy	Groupe bouchon	Verschlussgruppe Kpl	Grupo tapón	
<b>W</b>	49	8000 A6013	1	Gamba Sx. compl.	L.H. fork leg assy	Fourche complete G.	Telegabel Kpl. L.	Horquilla izrda. compl.	
<b>C</b>	49	8000 A5959	1	Gamba Sx. compl.	L.H. fork leg assy	Fourche complete G.	Telegabel Kpl. L.	Horquilla izrda. compl.	

**DA DEFINIRE**

**DA DEFINIRE**





TC-TE 250-450-510,  
SMR 450-510 / 2006

TAVOLA  
DRAWING  
TABLE  
BILD  
TABLA

20A

SOSPENSIONE ANTERIORE - FRONT FORK ASSEMBLY  
SUSPENSION AVANT - VORDERTELESKOPGABEL  
SUSPENSION DELANTERA

Note Notes Notes Markes Notas	Pos. No. N. Index Pos.	N. Cod. Code No. Nr. Code Code Nr N. Cod.	Q.tà Q.ty Q.te M.ge C.ad	DENOMINAZIONE	NAME	DESIGNATION	BESHREIBUNG	DENOMINACION	Validità Validity Validité Gültig Validez
<b>M</b>	49	8000 A6043	1	Gamba Sx. compl.	L.H. fork leg assy	Fourche complete G.	Telegabel Kpl. L.	Horquilla izrda. compl.	
<b>W</b>	50	8000 A6012	1	Gamba Dx. compl.	R.H. fork leg assy	Fourche complete D.	Telegabel Kpl. R.	Horquilla derech. compl.	
<b>C</b>	50	8000 A5960	1	Gamba Dx. compl.	R.H. fork leg assy	Fourche complete D.	Telegabel Kpl. R.	Horquilla derech. compl.	
<b>M</b>	50	8000 A6044	1	Gamba Dx. compl.	R.H. fork leg assy	Fourche complete D.	Telegabel Kpl. R.	Horquilla derech. compl.	
<b>WC</b>	51	8000 A0633	1	Piastrina	Plate	Plaquette	Plättchen	Placa	
<b>M</b>	51	8000 A6051	1	Piastrina	Plate	Plaquette	Plättchen	Placa	
	52	8A00 67997	2	Vite	Screw	Vis	Schraube	Tornillo	
	53	8000 61355	2	Dado	Nut	Ecrou	Mutter	Tueca	
	54	8000 69282	2	Bussola	Bush	Douille	Buchse	Manguito	
	55	8000 91519	1	Gruppo guarnizioni	Gasket set	Groupe garnitures	Dichtungssatz	Grupo juntas	
<b>WM</b>	56	8A00 65503	2	Rosetta piana	Washer	Rondelle	Scheibe	Arandela	
<b>C</b>	56	8000 87736	2	Rosetta piana	Washer	Rondelle	Scheibe	Arandela	
<b>WM</b>	57	8000 69315	1	Dado	Nut	Ecrou	Mutter	Tuerca	
<b>C</b>	57	8A00 69315	1	Dado	Nut	Ecrou	Mutter	Tuerca	
<b>WM</b>	58	8000 A5879	1	Mozzetto inferiore	Hub	Moyeau	Radnabe	Cbo	
<b>C</b>	58	8A00 A5879	1	Mozzetto inferiore	Hub	Moyeau	Radnabe	Cbo	
	59	8000 60233	4	Gommino	Rubber pad	Pièce caoutchouc	Gummstück	Junta de goma	
	60	8000 60234	2	Rosetta piana	Washer	Rondelle	Scheibe	Arandela	
	61	8000 53155	2	Distanziale	Spacer	Entretoise	Distanzstück	Separador	
	62	60N1 01224	2	Vite (M10x90 mm)	Screw(M10x90 mm)	Vis(M10x90 mm)	Schraube(M10x90 mm)	Tornillo(M10x90 mm)	
	63	8000 61314	2	Dado	Nut	Ecrou	Mutter	Tuerca	
<b>WM</b>	64	8000 A4092	2	Mozzetto superiore	Hub	Moyeau	Radnabe	Cubo	
<b>C</b>	64	8A00 A4092	2	Mozzetto superiore	Hub	Moyeau	Radnabe	Cubo	
	65	8C00 69056	4	Vite (M8x30 mm)	Screw (M8x30 mm)	Vis (M8x30 mm)	Schraube (M8x30 mm)	Tornillo (M8x30 mm)	
<b>W</b>	66	80B0 A5989	1	Protezione Sx. (codice colore E) <b>BLU</b>	Guard L.H. (color code E) <b>BLUE</b>	Protection D. (code couleur E) <b>BLEU</b>	Schutz L. (Code Farbe E) <b>BLAU</b>	Protección izq. (còdigo colòr E) <b>AZÚL</b>	
<b>C</b>	66	80A0 A5989	1	Protezione Sx. (codice colore G) <b>NERO</b>	Guard L.H. (color code E) <b>BLACK</b>	Protection D. (code couleur E) <b>NOIR</b>	Schutz L. (Code Farbe E) <b>SCHWARZ</b>	Protección izq. (còdigo colòr E) <b>NEGRO</b>	
<b>M</b>	66	80B0 A6631	1	Protezione Sx. (codice colore E) <b>BLU</b>	Guard L.H. (color code E) <b>BLUE</b>	Protection D. (code couleur E) <b>BLEU</b>	Schutz L. (Code Farbe E) <b>BLAU</b>	Protección izq. (còdigo colòr E) <b>AZÚL</b>	
<b>M</b>	66	80A0 A6631	1	Protezione Sx. (codice colore G) <b>NERO</b>	Guard L.H. (color code E) <b>BLACK</b>	Protection D. (code couleur E) <b>NOIR</b>	Schutz L. (Code Farbe E) <b>SCHWARZ</b>	Protección izq. (còdigo colòr E) <b>NEGRO</b>	
<b>W</b>	67	80B0 A5990	1	Protezione Dx.	Guard R.H.	Protection G.	Schutz R.	Protección der.	

**DA DEFINIRE**

**DA DEFINIRE**

Note Notes Notas	Pos. No. Index Pos.	N. Cod. Code No. Nr. Code Code Nr N. Cod.	Q.tà Q.ty Q.te M.ge C.ad	DENOMINAZIONE	NAME	DESIGNATION	BESHREIBUNG	DENOMINACION	Validità Validity Validité Gültig Validez
				(codice colore E) <b>BLU</b>	(color code E) <b>BLUE</b>	(code couleur E) <b>BLEU</b>	(Code Farbe E) <b>BLAU</b>	(còdigo colòr E) <b>AZÚL</b>	
<b>C</b>	67	80A0 A5990	1	Protezione Dx.	Guard R.H.	Protection G.	Schutz R.	Protección der.	
				(codice colore G) <b>NERO</b>	(color code E) <b>BLACK</b>	(code couleur E) <b>NOIR</b>	(Code Farbe E) <b>SCHWARZ</b>	(còdigo colòr E) <b>NEGRO</b>	
<b>M</b>	67	80B0 A6630	1	Protezione Dx.	Guard R.H.	Protection G.	Schutz R.	Protección der.	
				(codice colore E) <b>BLU</b>	(color code E) <b>BLUE</b>	(code couleur E) <b>BLEU</b>	(Code Farbe E) <b>BLAU</b>	(còdigo colòr E) <b>AZÚL</b>	
<b>M</b>	67	80A0 A6630	1	Protezione Dx.	Guard R.H.	Protection G.	Schutz R.	Protección der.	
				(codice colore G) <b>NERO</b>	(color code E) <b>BLACK</b>	(code couleur E) <b>NOIR</b>	(Code Farbe E) <b>SCHWARZ</b>	(còdigo colòr E) <b>NEGRO</b>	
	68	8000 62725	6	Vite	Screw	Vis	Schraube	Tornillo	
	69	8000 69429	6	Bussola	Bush	Douille	Buchse	Manguito	
	70	8000 93283	2	Anello	Ring	Bague	Ring	Anilo	
	71	8B00 66525	2	Vite	Screw	Vis	Schraube	Tornillo	
	72	8000 56443	2	Dado	Nut	Écrou	Mutter	Tuerca	
	74	8000 A6683	2	Distanziale	Spacer	Écarteur	Abstützstück	Separador	
<b>WM</b>	75	8000 62796	2	Vite (M8x40 mm) (400-450-510)	Screw (M8x40 mm) (400-450-510)	Vis (M8x40 mm) (400-450-510)	Schraube (M8x40 mm) (400-450-510)	Tornillo (M8x40 mm) (400-450-510)	
<b>C</b>	75	8000 62733	2	Vite (M8x35 mm) (450-510)	Screw (M8x35 mm) (450-510)	Vis (M8x35 mm) (450-510)	Schraube (M8x35 mm) (450-510)	Tornillo (M8x35 mm) (450-510)	
	76	8000 97750	1	Kit boccole	Bush kit	Kit douille	Buchsekit	Kit manguito	
	77	8000 97749	1	Kit anelli di tenuta	Seal ring kit	Kit bague de retenue	Dichtringkit	Kit anillo de retención	
	78	8000 98782	1	Kit lamelle (0,1 mm)	Plate kit (0,1 mm)	Kit lamelle (0,1 mm)	Plättchenkit (0,1 mm)	Kit Laminilla (0,1 mm)	
	79	8000 98783	1	Kit lamelle (0,2 mm)	Plate kit (0,2 mm)	Kit lamelle (0,2 mm)	Plättchenkit (0,2 mm)	Kit Laminilla (0,2 mm)	
	80	8000 98784	1	Kit lamelle (0,3 mm)	Plate kit (0,3 mm)	Kit lamelle (0,3 mm)	Plättchenkit (0,3 mm)	Kit Laminilla (0,3 mm)	
	81	8000 98785	1	Kit lamelle (0,4 mm)	Plate kit (0,4 mm)	Kit lamelle (0,4 mm)	Plättchenkit (0,4 mm)	Kit Laminilla (0,4 mm)	
<b>Y</b>	82	8000 74842	2	Catadiottro ambra (AUS)	Reflector amber (AUS)	Catadioptrique ambre (AUS)	Rückstrahler Amber (AUS)	Catafaros àmbar (AUS)	
<b>CU</b>	82	8000 74842	2	Catadiottro ambra (CDN)	Reflector amber (CDN)	Catadioptrique ambre (CDN)	Rückstrahler Amber (CDN)	Catafaros àmbar (CDN)	
<b>R</b>	83	8000 80260	1	Olio forcella	Front fork oil	Huile fourche avant	Öl für die Vordergabel	Aceite horquilladelantera	
<b>a</b>				Forniti anche in gruppo pos. 55	Supplied in bag ref. N° 55	Son fournies en unités pos. 55	Sind im Umschlag Bez. Nr 55	Provisto en grupo pos. 55	
<b>b</b>				Forniti anche in gruppo pos. 76	Supplied in bag ref. N° 76	Son fournies en unités pos. 76	Sind im Umschlag Bez. Nr 76	Provisto en grupo pos. 76	
<b>c</b>				Forniti anche in gruppo pos. 77	Supplied in bag ref. N° 77	Son fournies en unités pos. 77	Sind im Umschlag Bez. Nr 77	Provisto en grupo pos. 77	
<b>d</b>				Forniti anche in gruppo pos. 78, 79, 80, 81	Supplied in bag ref. N° 78, 79, 80, 81	Son fournies en unités pos. 78, 79, 80, 81	Sind im Umschlag Bez. Nr 78, 79, 80, 81	Provisto en grupo pos. 78, 79, 80, 81	

**DA DEFINIRE**

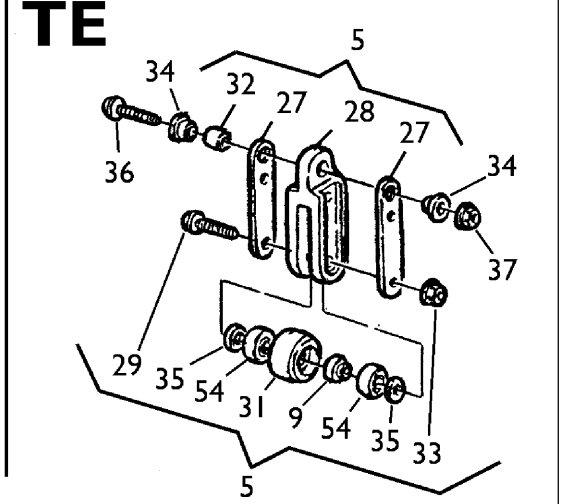
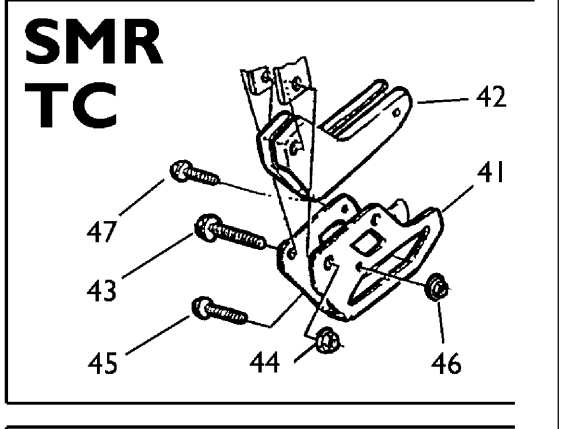
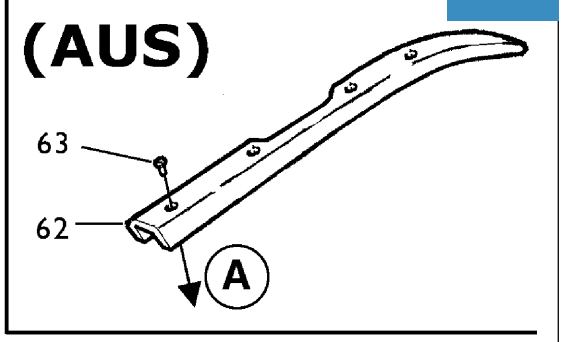
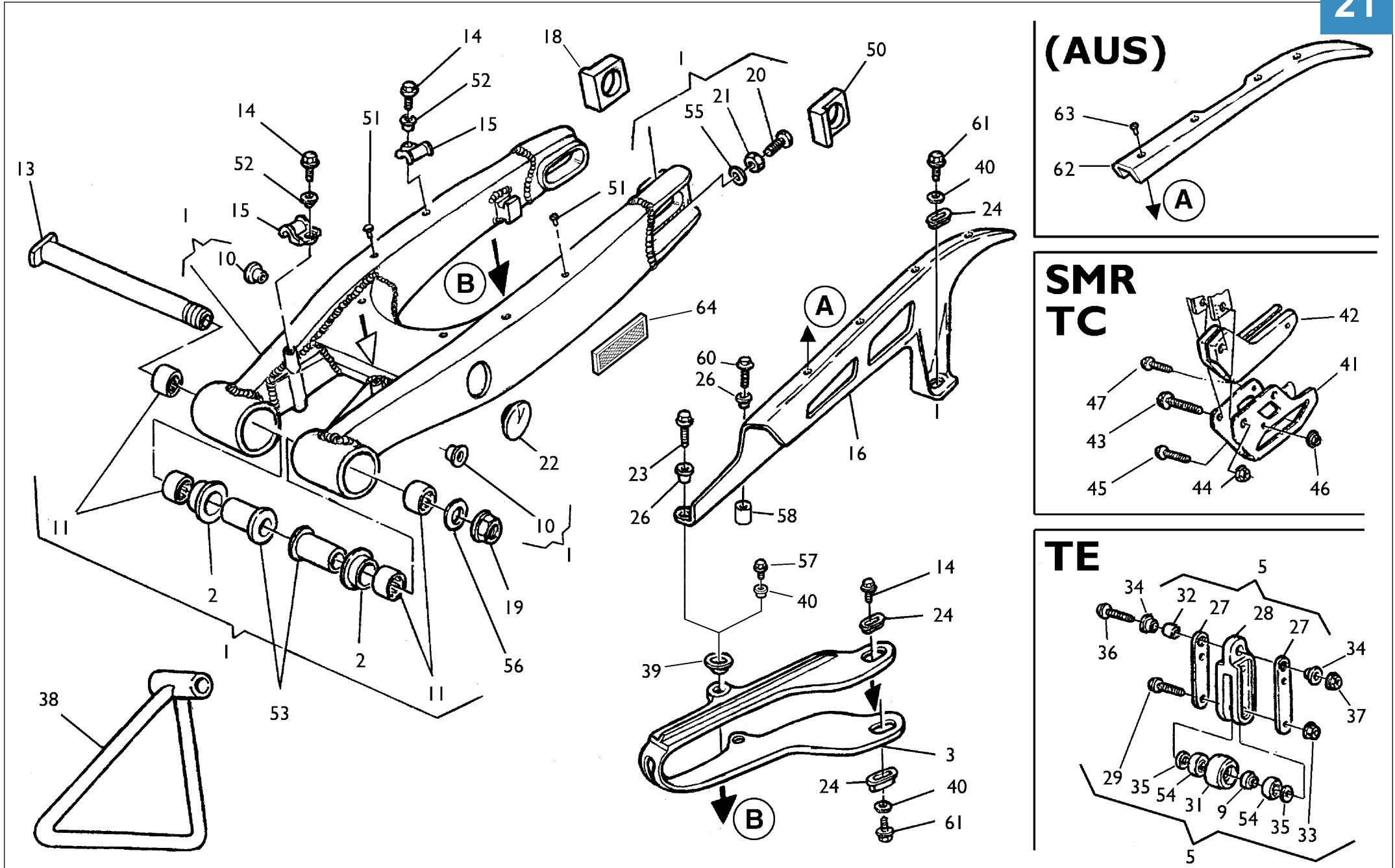

Note Notes Notas	Pos. No. N. Index Pos.	N. Cod. Code No. Nr. Code Code Nr N. Cod.	Q.tà Q.ty Q.te M.ge C.ad	DENOMINAZIONE	NAME	DESIGNATION	BESHREIBUNG	DENOMINACION	Validità Validity Validité Gültig Validez
	1	8000 A4404	1	Forcellone completo	Swing arm assy.	Fourche complete	Gabel, Kpl.	Horquilla compl.	
	2	8000 71622	2	Bussola	Bushing	Douille	Buchse	Manguito	
	3	8000 99619	1	Pattino catena	Chain slider	Glissière	Gleitbahn	Plato catena	
<b>W</b>	5	8000 72873	1	Ass. guidacatena	Chain guide	Guide chaine	Kettenführung	Guja catena	
<b>W</b>	9	8000 65412	1	Distanziale	Spacer	Entretoise	Distanzstück	Separador	
	10	8000 87810	1	Bussola Sp.16 mm (lato disco)	R.H. bushing (th.16 mm)	Douille D. (épaisseur 16 mm)	Buchse R. (Dicken 16 mm)	Manguito der. (esp.16 mm)	
	10	8A00 87810	1	Bussola Sp.13 mm (lato corona)	L.H. bushing (th.13 mm)	Douille G. (épaisseur 13 mm)	Buchse L. (Dicken 13 mm)	Manguito iz. (esp.13 mm)	
	11	8000 76283	4	Gabbia a rullini (ø22xø28x18 mm)	Needle cage (ø22xø28x18 mm)	Cage à aiguilles (ø22xø28x18 mm)	Nadelkaefig (ø22xø28x18 mm)	Jaula de agujas del cojinete (ø22xø28x18 mm)	
	13	8000 71620	1	Perno forcellone	Fork pin	Pivot fourche	Gabelbolzen	Perno horquilla	
	14	8000 20536	1	Vite posteriore (Ø4,8x13 mm)	Rear screw (Ø4,8x13 mm)	Vis arriere(Ø4,8x13 mm)	Hinterschraube (Ø4,8x13 mm)	Tornillo trasero (Ø4,8x13 mm)	
	14	8000 67997	1	Vite anteriore (M5x12 mm)	Front screw (M5x12 mm)	Vis avant (M5x12 mm)	Vorderschraube (M5x12 mm)	Tornillo delantero (M5x12 mm)	
	15	80A0 73456	2	Guidacavo	Cable guide	Guide câble	Kabelführung	Guía-cable	
<b>WM</b>	16	8AA0 73909	1	Copricatena	Chain guard	Carter de chaine	Kettenkasten	Cubre-cadena	
	18	8000 96944	2	Tendicatena DX	Chain adjuster R.	Tendeur de chaine D.	Kettenspanner R.	Tensor de cadena D.	
	19	8000 71623	1	Dado	Nut	Ecrou	Mutter	.Tuerca	
	20	8C00 61121	2	Vite	Screw	Vis	Schraube	Tornillo	
	21	8000 17810	2	Dado	Nut	Ecrou	Mutter	Tuerca	
	22	80A0 74388	2	Tappo	Plug	Bouchon	Verschluss	Tapón	
<b>WM</b>	23	8A00 67997	1	Vite (M5x16 mm)	Screw (M5x16 mm)	Vis (M5x16 mm)	Schraube (M5x16 mm)	Tornillo (M5x16 mm)	
	24	8000 59289	3	Scodellino	Cup	Cuvette	Teller	Cubeta	
<b>WM</b>	26	8A00 69282	2	Bussola	Bushing	Douille	Buchse	Manguito	
<b>W</b>	27	8000 72875	2	Piastra d'attacco	Plate	Plaque	Platte	Placa	
<b>W</b>	28	8000 72874	1	Guidacatena	Chain guide	Guide-chaine	Kettenführung	Guía-cadena	
<b>W</b>	29	8000 62731	2	Vite (M6x45 mm)	Screw (M6x45 mm)	Vis (M6x45 mm)	Schraube (M6x45 mm)	Tornillo (M6x45 mm)	
<b>W</b>	31	8000 65411	1	Rullo	Roller	Aiguille	Rolle	Rodillo	
<b>W</b>	32	1515 50601	1	Bussola	Bushing	Douille	Buchse	Manguito	
<b>W</b>	33	8000 44240	2	Dado	Nut	Ecrou	Mutter	Tuerca	
<b>W</b>	34	8A00 66661	2	Bussola	Bushing	Douille	Buchse	Manguito	
<b>W</b>	35	8000 45495	2	Boccola di spallamento	Washer	Rondelle	Scheibe	Arandela	
<b>W</b>	36	8000 62795	1	Vite	Screw	Vis	Schraube	Tornillo	
<b>W</b>	37	8000 43928	1	Dado	Nut	Ecrou	Mutter	Tuerca	

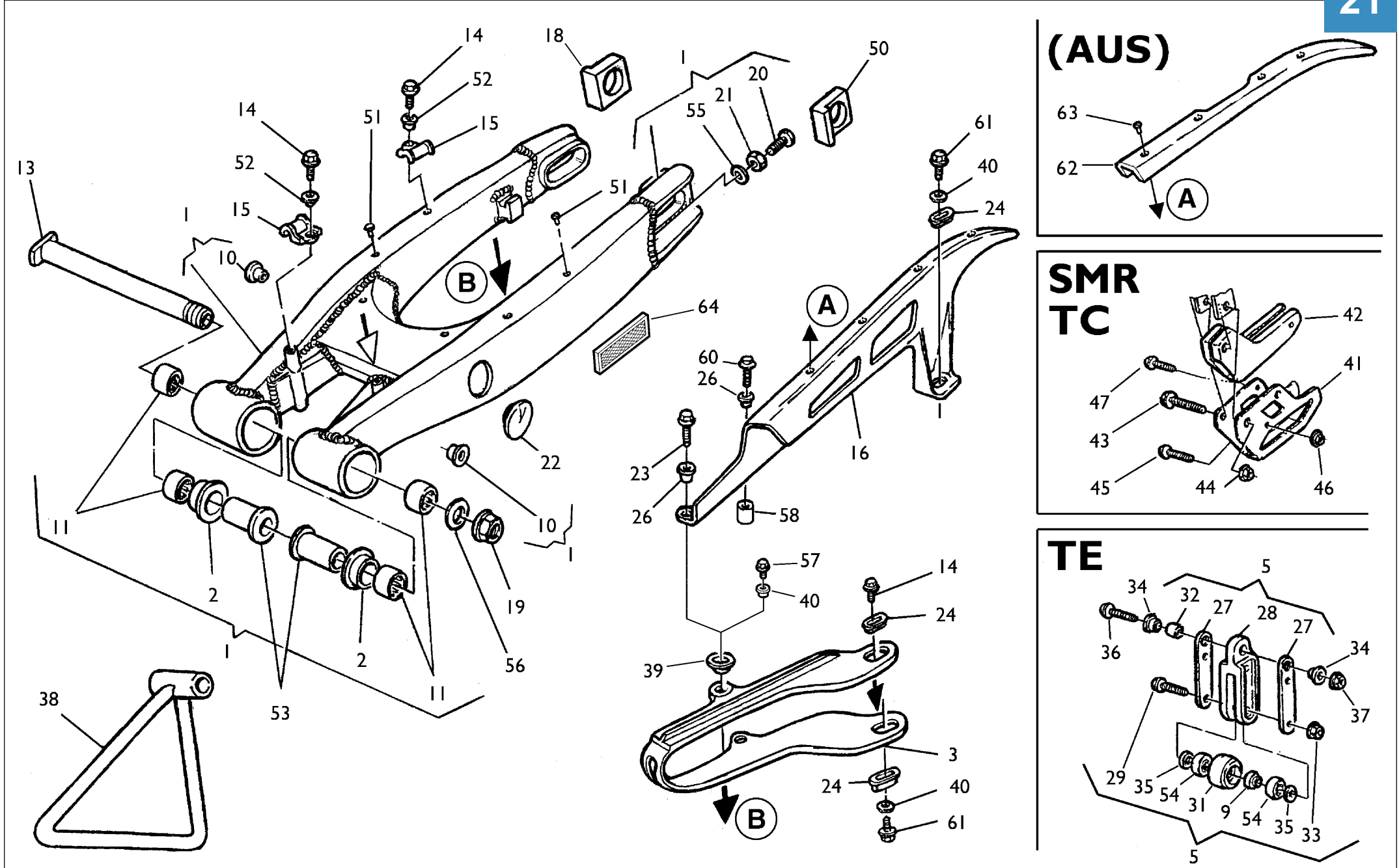



Note Notes Marke Notas	Pos. No. N. Index Pos.	N. Cod. Code No. Nr. Code Code Nr N. Cod.	Q.tà Q.ty Q.te M.ge C.ad	DENOMINAZIONE	NAME	DESIGNATION	BESHREIBUNG	DENOMINACION	Validità Validity Validité Gültig Validez
<b>C</b>	38	8000 74016	1	Gamba laterale	Side stand	Bequille lat.	Seitenstander	Horquilla lateral	
	39	8000 75166	4	Scodellino	Cup	Cuvette	Teller	Cubeta	
	40	8000 36137	4	Rosetta piana	Washer	Rondelle	Scheibe	Arandela	
<b>MC</b>	41	8000 72869	1	Staffa	Bracket	Entier	Buegel	Brida	
<b>MC</b>	42	8000 72868	1	Guidacatena	Chain guide	Guidechaine	Kettenführung	Guiacadena	
<b>MC</b>	43	8000 62795	1	Vite (M8x50 mm)	Screw (M8x50 mm)	Vis (M8x50 mm)	Schraube (M8x50 mm)	Tornillo (M8x50 mm)	
<b>MC</b>	44	8000 43928	1	Dado	Nut	Ecrou	Mutter	Tuerca	
<b>MC</b>	45	8000 62731	1	Vite (M6x45 mm)	Screw (M6x45 mm)	Vis (M6x45 mm)	Schraube (M6x45 mm)	Tornillo (M6x45 mm)	
<b>MC</b>	46	8000 44240	1	Dado	Nut	Ecrou	Mutter	Tuerca	
<b>MC</b>	47	8000 62725	1	Vite (M6x10 mm)	Screw (M6x10 mm)	Vis (M6x10 mm)	Schraube (M6x10 mm)	Tornillo (M6x10 mm)	
	50	8000 96941	1	Tendicatena SX	Chain adjuster L.	Tendeur de chaine G.	Kettenspanne L.	Tensor de cadena I.	
	51	8000 75160	4	Rivetto	Rivet	Rivet	Niet	Remache	
	52	8000 69282	2	Bussola	Bushing	Douille	Buchse	Manguito	
	53	8000 71621	2	Bussola	Bushing	Douille	Buchse	Manguito	
<b>W</b>	54	8000 63312	2	Cuscinetto (ø8xØ22x7 mm)	Bearing (ø8xØ22x7 mm)	Roulement (ø8xØ22x7 mm)	Lager (ø8xØ22x7 mm)	Cojinete (ø8xØ22x7 mm)	
	55	8000 08536	2	Rosetta piana	Washer	Rondelle	Scheibe	Arandela	
	56	8000 32388	1	Rosetta	Washer	Rondelle	Scheibe	Arandela	
	57	8000 67997	2	Vite	Screw	Vis	Schraube	Tornillo	
<b>WM</b>	58	8000 97025	1	Bussola	Bushing	Douille	Buchse	Manguito	
<b>WM</b>	60	60N1 01059	1	Vite (M5x35 mm)	Screw (M5x35 mm)	Vis (M5x35 mm)	Schraube (M5x35 mm)	Tornillo (M5x35 mm)	
	61	8000 20536	3	Vite (Ø4,8x13 mm)	Screw (Ø4,8x13 mm)	Vis (Ø4,8x13 mm)	Schraube (Ø4,8x13 mm)	Tornillo (Ø4,8x13 mm)	
<b>WM</b>	62	8000 A2352	1	Prolunga per guidacatena (AUS)	Chain guide extension (AUS)	Guidechaine extension (AUS)	Kettenführungverlängerung (AUS)	Prolonga por guiacadena (AUS)	
<b>WM</b>	63	8000 81628	4	Vite (AUS)	Screw (AUS)	Vis (AUS)	Schraube (AUS)	Tornillo (AUS)	
	64	8000 73832	2	Catadiottro rosso (U.S.A.-CDN)	Reflector red (U.S.A.-CDN)	Catadioptrique rouge (U.S.A.-CDN)	Rückstrahler Rot (U.S.A.-CDN)	Catafaros rojo (U.S.A.-CDN)	

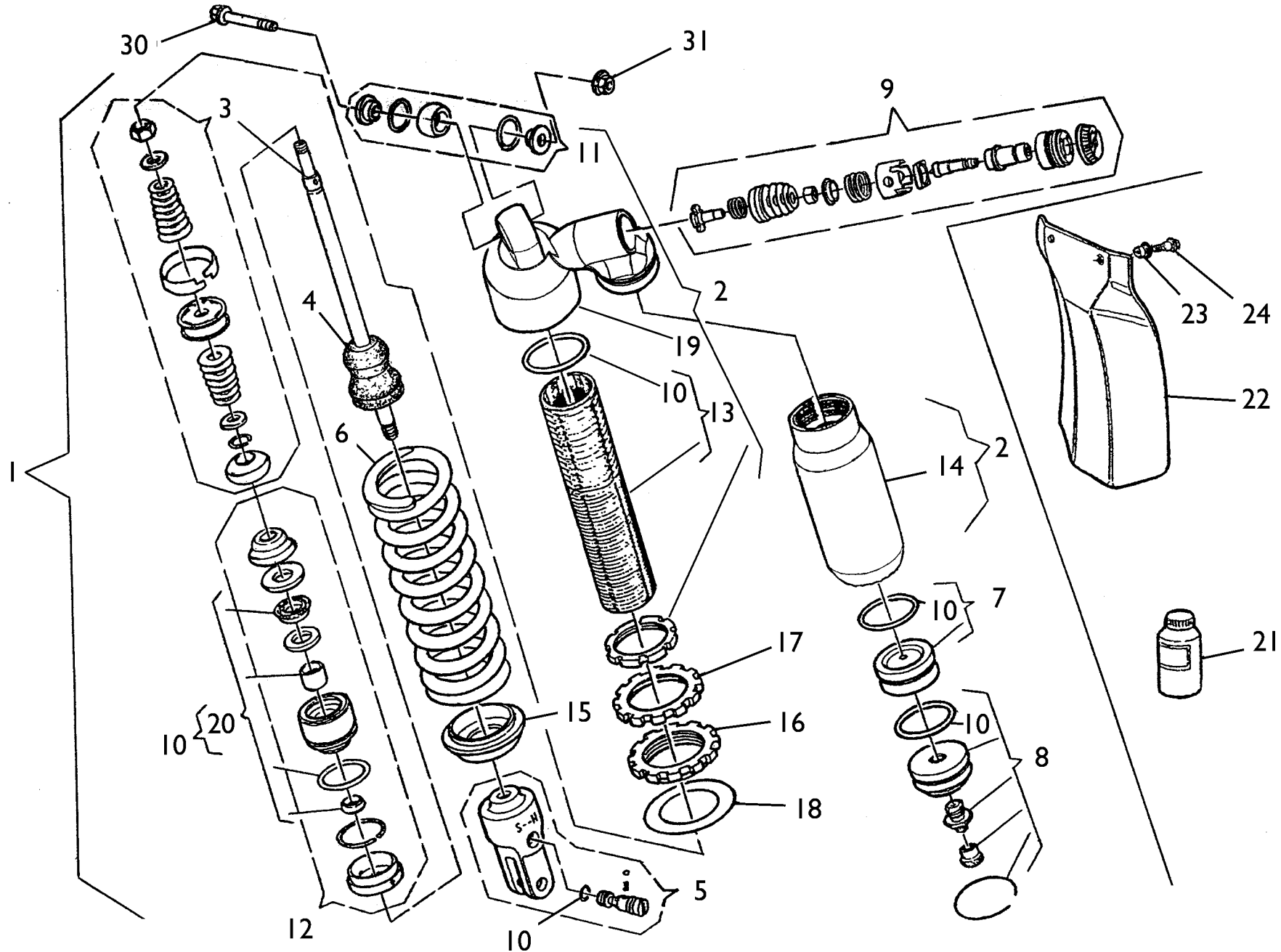

Note Notes Notas	Pos. No. N. Index Pos.	N. Cod. Code No. Nr. Code Code Nr N. Cod.	Q.tà Q.ty Q.te M.ge C.ad	DENOMINAZIONE	NAME	DESIGNATION	BESHREIBUNG	DENOMINACION	Validità Validity Validité Gültig Validez
	1	8000 A4409	1	Ammort. compl. (TE 250)	Shock-absorber (TE 250)	Ammortisseur (TE 250)	Stossdampfer (TE 250)	Amortigüador (TE 250)	
	1	8000 A4410	1	Ammort. compl. (TE 450-510)	Shock-absorber (TE 450-510)	Ammortisseur (TE 450-510)	Stossdampfer (TE 450-510)	Amortigüador (TE 450-510)	
	1	8000 A4413	1	Ammort. compl. (SMR)	Shock-absorber (SMR)	Ammortisseur (SMR)	Stossdampfer (SMR)	Amortigüador (SMR)	
<b>M</b>	2	8000 A5065	1	Gruppo corpo	Damper case assy	Groupe corps amortisseur	Stossdämpferkörper Kpl.	Corpo amortigüador compl.	
<b>W</b>	2	8000 A3644	1	Gruppo corpo	Damper case assy	Groupe corps amortisseur	Stossdämpferkörper Kpl.	Corpo amortigüador compl.	
	3	8000 A5067	1	Gruppo stelo (TE 250)	Rod assy (TE 250)	Groupe tige (TE 250)	Pumpenstückgruppe (TE 250)	Grupo espiga (TE 250)	
	3	8000 A5068	1	Gruppo stelo (TE 450-510)	Rod assy (TE 450-510)	Groupe tige (TE 450-510)	Pumpenstückgr. (TE 450-510)	Grupo espiga (TE 450-510)	
	3	8000 A5070	1	Gruppo stelo (SMR)	Rod assy (SMR)	Groupe tige (SMR)	Pumpenstückgruppe (SMR)	Grupo espiga (SMR)	
	4	8000 91238	1	Tampone	Pad	Tampon	Stopfen	Tampòn	
<b>W</b>	5	8000 A1507	1	Gruppo forcella	Fork assy	Groupe fourche	Gabelgruppe Kpl.	Grupo horquilla	
<b>M</b>	5	8000 98489	1	Gruppo forcella	Fork assy	Groupe fourche	Gabelgruppe Kpl.	Grupo horquilla	
	6	8000 98569	1	Molla (k=5,2 Kg/mm)	Spring (k=5,2 Kg/mm)	Ressort (k=5,2 Kg/mm)	Feder (k=5,2 Kg/mm)	Resorte (k=5,2 Kg/mm)	
				(TE 250)	(TE 250)	(TE 250)	(TE 250)	(TE 250)	
	6	8000 98504	1	Molla (k=5,4 Kg/mm)	Spring (k=5,4 Kg/mm)	Ressort (k=5,4 Kg/mm)	Feder (k=5,4 Kg/mm)	Resorte (k=5,4 Kg/mm)	
				(TE 450-510)	(TE 450-510)	(TE 450-510)	(TE 450-510)	(TE 450-510)	
	6	8000 98520	1	Molla (k=6,4 Kg/mm)	Spring (k=6,4 Kg/mm)	Ressort (k=6,4 Kg/mm)	Feder (k=6,4 Kg/mm)	Resorte (k=6,4 Kg/mm)	
				(SMR)	(SMR)	(SMR)	(SMR)	(SMR)	
	7	8000 A5071	1	Diaframma	Diaphragm	Diaphragme	Biegeplatte	Diafragma	
	8	8000 A1508	1	Gruppo serbatoio	Tank assy	Groupe reservoir	Tankgruppe Kpl.	Grupo deposito compl.	
	9	8000 98492	1	Gruppo regolazione	Adjuster set	Groupe réglage	Reglergruppe Kpl.	Grupo regulacion	
	10	8000 A5072	1	Gruppo guarnizioni	Gasket set	Groupe garnitures	Dichtungssatz	Grupo juntas	
	11	8000 89089	1	Gruppo snodo	Ball joint assy	Groupe joint a rotule	Kugelgelenkgruppe Kpl.	Grupo articulaciòn esferica	
	12	8000 A3648	1	Gruppo guida stelo	Guide rod assy	Groupe guide tige	Pumpenstückführunggruppe	Grupo guja espiga	
<b>M</b>	13	8000 A5074	1	Corpo ammortizzatore	Damper case	Corps amortisseur	Stossdämpferkörper	Corpo amortigüador	
<b>W</b>	13	8000 A3649	1	Corpo ammortizzatore	Damper case	Corps amortisseur	Stossdämpferkörper	Corpo amortigüador	
	14	8000 A3650	1	Serbatoio	Tank	Reservoir	Tank	Deposito	
	15	8000 98496	1	Fondello	Bottom	Fond	Bodenscheibe	Casquilo	
	16	8000 98497	1	Ghiera	Ring nut	Embout	Nutmutter	Virola	
	17	8000 98498	1	Controghiera	Ring nut	Embout	Nutmutter	Virola	
	18	8000 98499	1	Rosetta per molla	Washer	Rondelle	Scheibe	Arandela	
	19	8000 98503	1	Supporto serbatoio	Tank support	Support reservoir	Gastankhalterung	Soporte deposito	
<b>W</b>	20	8000 A3651	1	Gruppo guarnizioni per stelo	Rod gasket set	Jeu joints pour tige	Dichtungs für Pumpenstock	Serie juntas por espiga	
<b>M</b>	20	8000 A5364	1	Gruppo guarnizioni per stelo	Rod gasket set	Jeu joints pour tige	Dichtungs für Pumpenstock	Serie juntas por espiga	

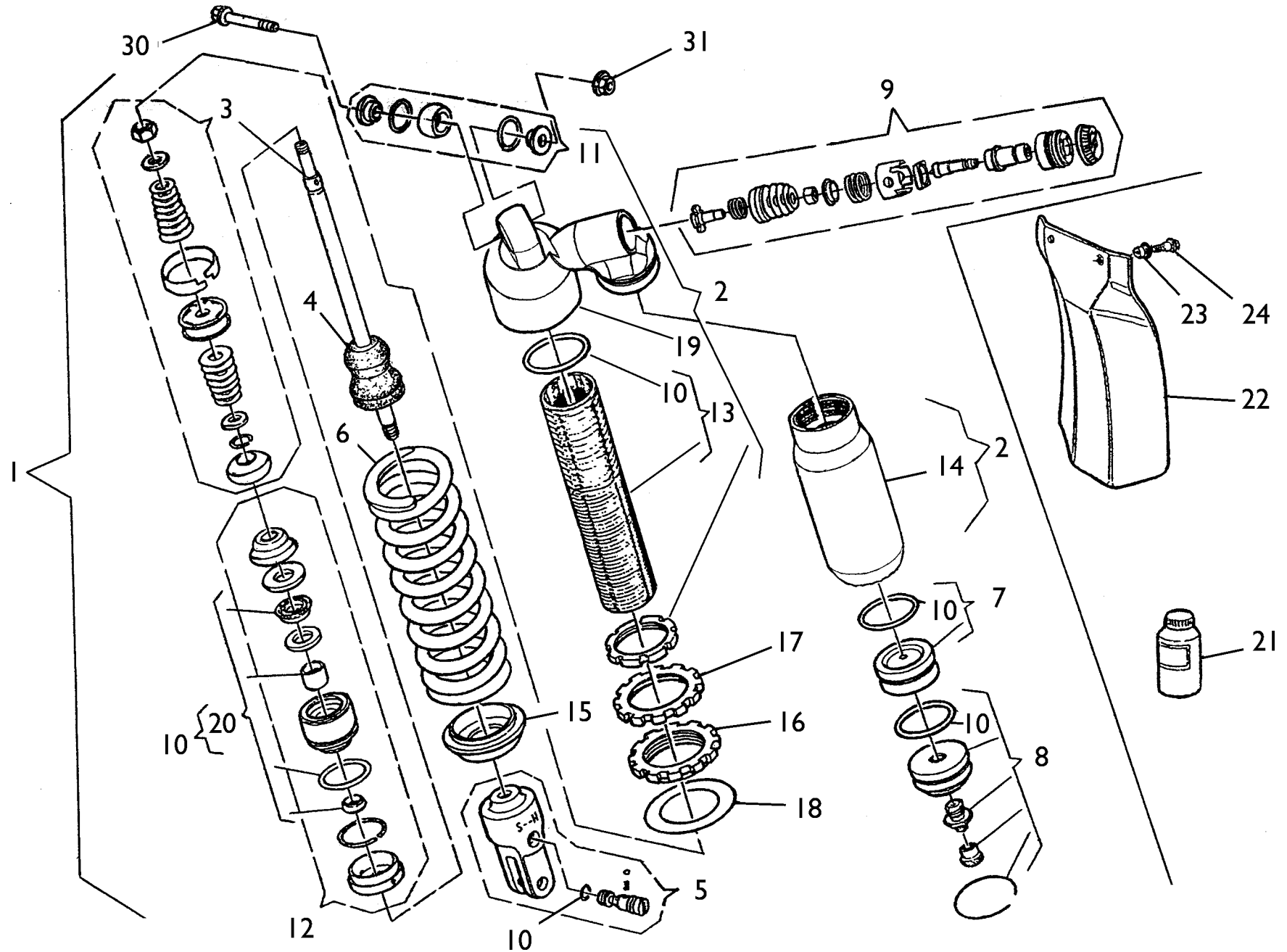



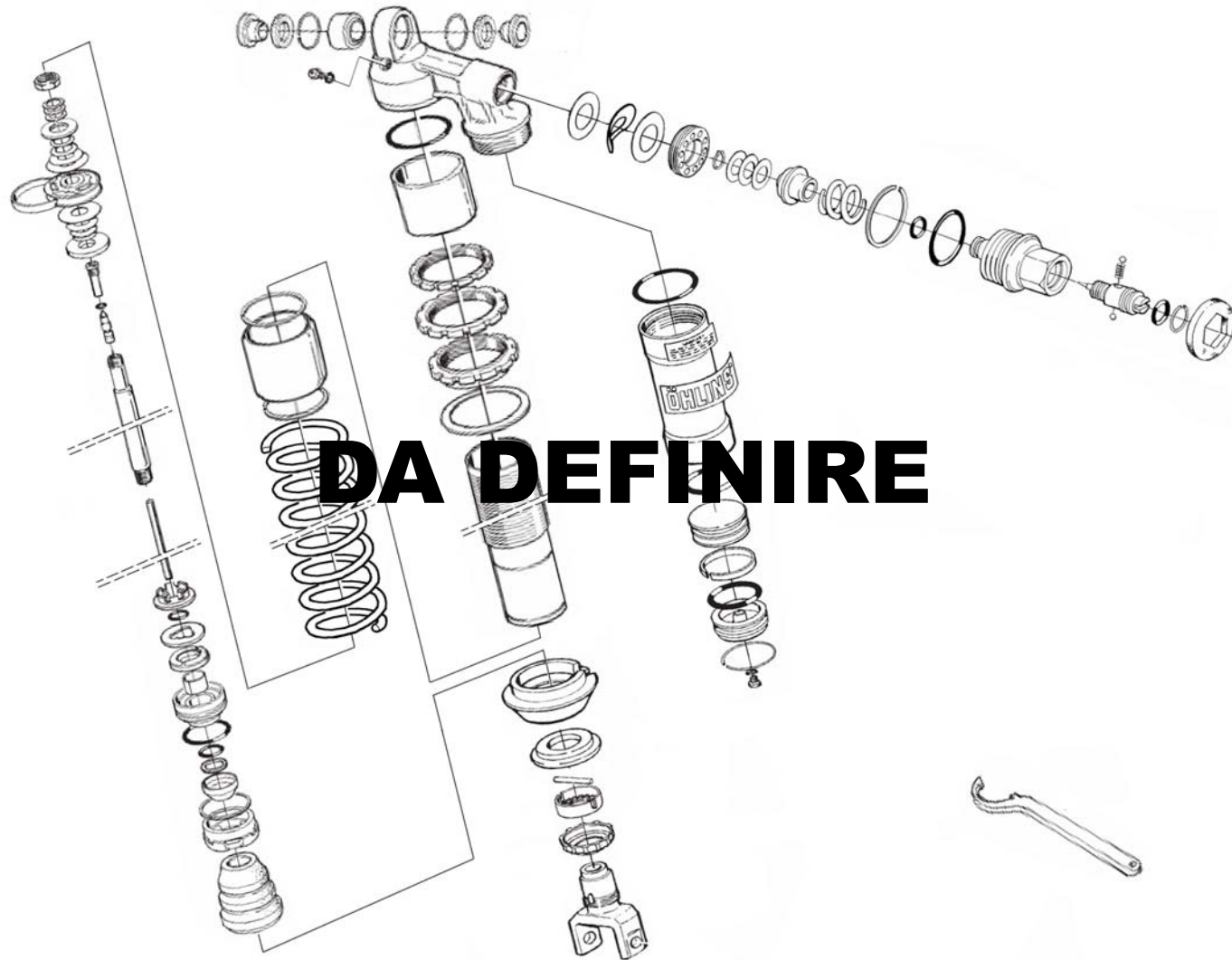



Note Notes Notas	Pos. No. Index	N. Cod. Code No. Nr. Code Code Nr N. Cod.	Q.tà Q.ty Q.te M.ge C.ad	DENOMINAZIONE	NAME	DESIGNATION	BESHREIBUNG	DENOMINACION	Validità Validity Validité Gültig Validez
	1	8000 A6041	1	Ammort. compl. (TC)	Shock-absorber (TC)	Ammortisseur (TC)	Stossdämpfer (TC)	Amortiguador (TC)	
<b>WC</b>	2	8000 A3644	1	Gruppo corpo	Damper case assy	Groupe corps ammortisseur	Stossdämpferkörper Kpl.	Corpo amortiguador compl.	
	3	8000 A5067	1	Gruppo stelo (TE 250)	Rod assy (TE 250)	Groupe tige (TE 250)	Pumpenstückgruppe (TE 250)	Grupo espiga (TE 250)	
	3	8000 A5069	1	Gruppo stelo (TC)	Rod assy (TC)	Groupe tige (TC)	Pumpenstückgruppe (TC)	Grupo espiga (TC)	
	3	8000 A5068	1	Gruppo stelo (TE 450-510)	Rod assy (TE 450-510)	Groupe tige (TE 450-510)	Pumpenstückgr. (TE 450-510)	Grupo espiga (TE 450-510)	
	3	8000 A5070	1	Gruppo stelo (SMR)	Rod assy (SMR)	Groupe tige (SMR)	Pumpenstückgruppe (SMR)	Grupo espiga (SMR)	
<b>WC</b>	4	8000 91238	1	Tampone	Pad	Tampon	Stopfen	Tampòn	
<b>M</b>	5	8000 A1507	1	Gruppo forcella	Fork assy	Groupe fourche	Gabelgruppe Kpl.	Grupo horquilla	
<b>M</b>	5	8000 98489	1	Gruppo forcella	Fork assy	Groupe fourche	Gabelgruppe Kpl.	Grupo horquilla	
	6	8000 98569	1	Molla (k=5,2 Kg/mm) (TE 250)	Spring (k=5,2 Kg/mm) (TE 250)	Ressort (k=5,2 Kg/mm) (TE 250)	Feder (k=5,2 Kg/mm) (TE 250)	Resorte (k=5,2 Kg/mm) (TE 250)	
	6	8000 98504	1	Molla (k=5,4 Kg/mm) (TC, TE 450-510)	Spring (k=5,4 Kg/mm) (TC, TE 450-510)	Ressort (k=5,4 Kg/mm) (TC, TE 450-510)	Feder (k=5,4 Kg/mm) (TC, TE 450-510)	Resorte (k=5,4 Kg/mm) (TC, TE 450-510)	
	6	8000 98520	1	Molla (k=6,4 Kg/mm) (SMR)	Spring (k=6,4 Kg/mm) (SMR)	Ressort (k=6,4 Kg/mm) (SMR)	Feder (k=6,4 Kg/mm) (SMR)	Resorte (k=6,4 Kg/mm) (SMR)	
	7	8000 A5071	1	Diaframma	Diaphragm	Diaphragme	Biegeplatte	Diafragma	
	8	8000 A1508	1	Gruppo serbatoio	Tank assy	Groupe reservoir	Tankgruppe Kpl.	Grupo deposito compl.	
	9	8000 98492	1	Gruppo regolazione	Adjuster set	Groupe réglage	Reglergruppe Kpl.	Grupo regulacion	
	10	8000 A5072	1	Gruppo guarnizioni	Gasket set	Groupe garnitures	Dichtungssatz	Grupo juntas	
	11	8000 89089	1	Gruppo snodo	Ball joint assy	Groupe joint a rotule	Kugelgelenkgruppe Kpl.	Grupo articulaciòn esferica	
	12	8000 A3648	1	Gruppo guida stelo	Guide rod assy	Groupe guide tige	Pumpenstückführungsgruppe	Grupo guja espiga	
<b>M</b>	13	8000 A5074	1	Corpo ammortizzatore	Damper case	Corps ammortisseur	Stossdämpferkörper	Corpo amortiguador	
<b>WC</b>	13	8000 A3649	1	Corpo ammortizzatore	Damper case	Corps ammortisseur	Stossdämpferkörper	Corpo amortiguador	
	14	8000 A3650	1	Serbatoio	Tank	Reservoir	Tank	Deposito	
	15	8000 98496	1	Fondello	Bottom	Fond	Bodenscheibe	Casquilo	
	16	8000 98497	1	Ghiera	Ring nut	Embout	Nutmutter	Virola	
	17	8000 98498	1	Controghiera	Ring nut	Embout	Nutmutter	Virola	
	18	8000 98499	1	Rosetta per molla	Washer	Rondelle	Scheibe	Arandela	
	19	8000 98503	1	Supporto serbatoio	Tank support	Support reservoir	Gastankhalterung	Soporte deposito	
<b>WC</b>	20	8000 A3651	1	Gruppo guarnizioni per stelo	Rod gasket set	Jeu joints pour tige	Dichtungs für Pumpenstock	Serie juntas por espiga	
<b>M</b>	20	8000 A5364	1	Gruppo guarnizioni per stelo	Rod gasket set	Jeu joints pour tige	Dichtungs für Pumpenstock	Serie juntas por espiga	
<b>R</b>	21	8000 88231	1	Olio ammortizzatore	Shock-absorber oil	Huile ammortisseur	Öl für Stossdämpfer	Aceite amortiguador	
	22	80A0 69551	1	Protezione ammortizzatore	Guard	Protection	Schutz	Protección	

DA DEFINIRE

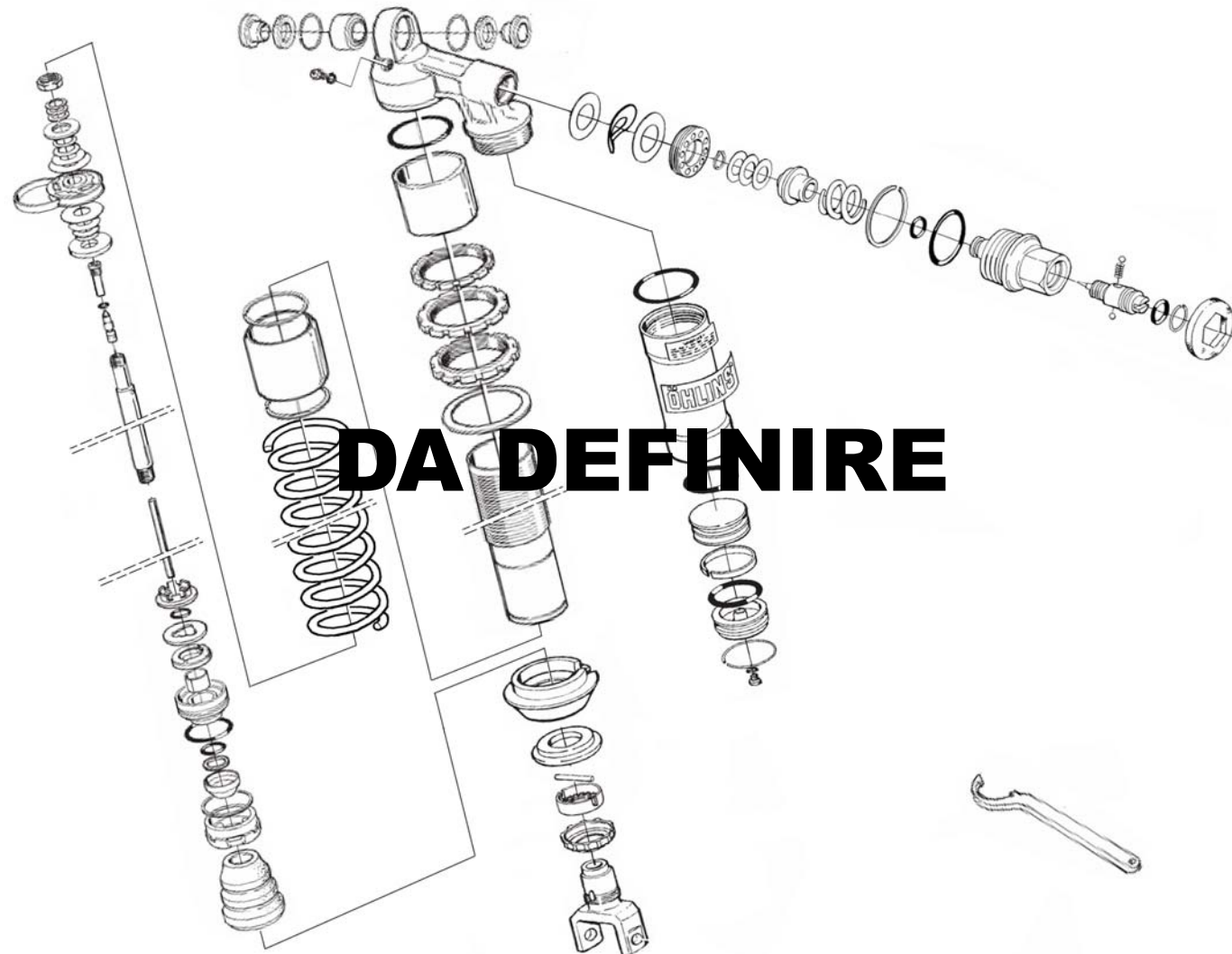

Note Notes Marke Notas	Pos. No. N. Index Pos.	N. Cod. Code No. Nr. Code Code Nr N. Cod.	Q.tà Q.ty Q.te M.ge C.ad	DENOMINAZIONE	NAME	DESIGNATION	BESHREIBUNG	DENOMINACION	Validità Validity Validité Gültig Validez
	23	8000 69429	4	Bussola	Bushing	Douille	Buchse	Manguito	
	24	8000 62726	4	Vite	Screw	Vis	Schraube	Tornillo	
	30	8A00 62797	1	Vite (M10x50 mm)	Screw (M10x50 mm)	Vis (M10x50 mm)	Schraube (M10x50 mm)	Tornillo (M10x50 mm)	
	31	8000 42022	1	Dado	Nut	Ecrou	Mutter	Tuerca	
<b>DA DEFINIRE</b>									

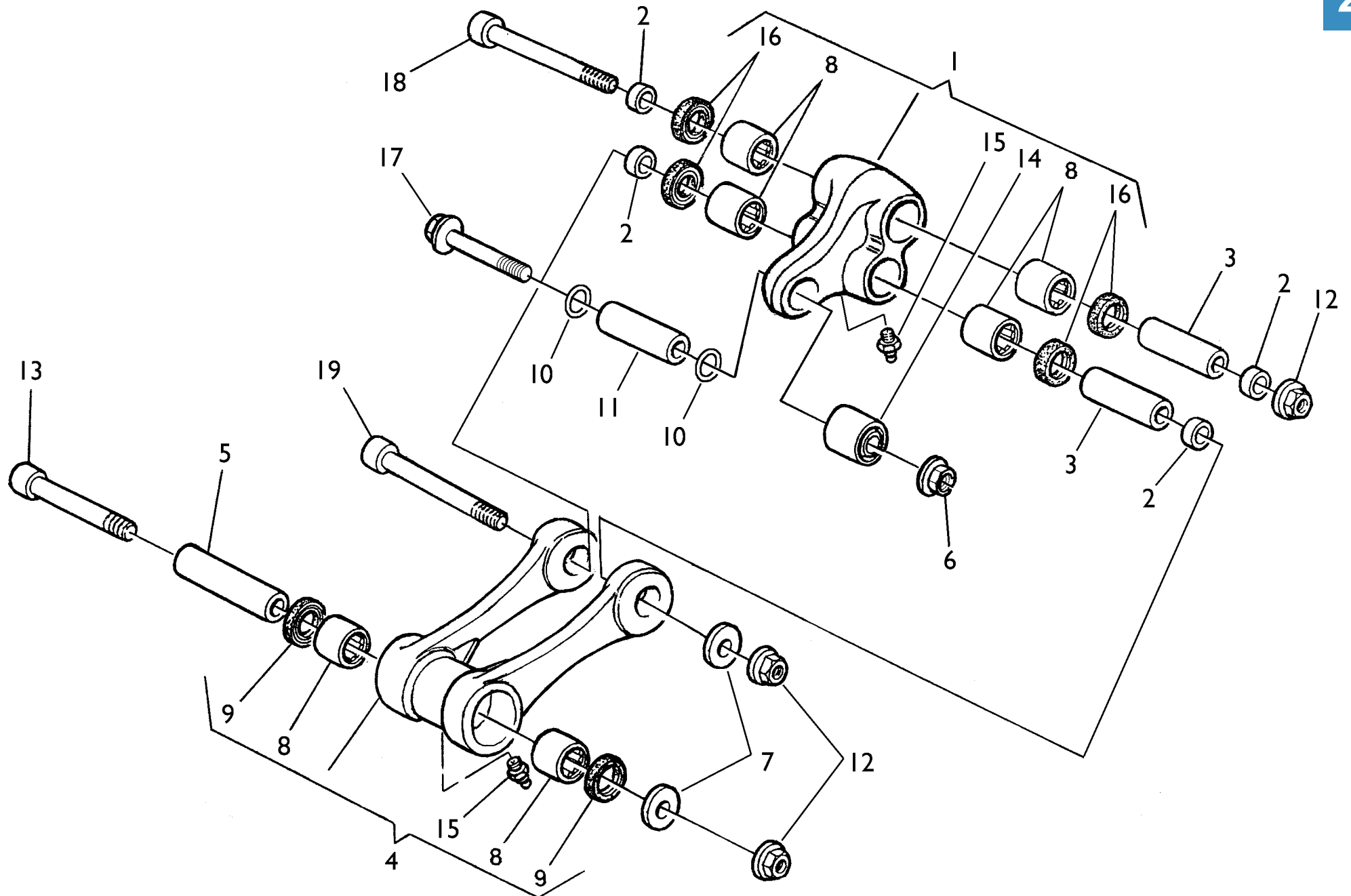

Note Notes Notas	Pos. No. Index Pos.	N. Cod. Code No. Nr. Code Code Nr N. Cod.	Q.tà Q.ty Q.te M.ge C.ad	DENOMINAZIONE	NAME	DESIGNATION	BESHREIBUNG	DENOMINACION	Validità Validity Validité Gültig Validez
	1	8000 A4429	1	Assieme bilanciere	Rocking lever assy	Balancier compl.	Schwinge Kpl.	Balancines compl.	
	2	8000 86177	4	Distanziale	Spacer	Entretoise	Distanzstück	Separadòr	
	3	8000 86176	2	Spinotto	Gudgeon	Axe	Bolzen	Perno	
	4	8000 A4428	1	Tirante completo	Tie rod	Tirant	Spannstange	Tirante	
	5	8000 97050	1	Spinotto	Gudgeon	Axe	Bolzen	Perno	
	6	8000 42022	1	Dado	Nut	Ecrou	Mutter	Tuerca	
	7	8000 86140	2	Rosetta	Washer	Rondelle	Scheibe	Arandela	
	8	8000 A4427	6	Cuscinetto (ø22xø28x20 mm)	Bearing (ø22xø28x20 mm)	Roulement (ø22xø28x2 mm)	Lager (ø22xø28x20 mm)	Cojinete (ø22xø28x20 mm)	
	9	8000 38521	2	Anello di tenuta (ø22xø28x4 mm)	Seal ring (ø22xø28x4 mm)	Bague de retenue (ø22xø28x4 mm)	Dichtring (ø22xø28x4 mm)	Anillo de retención (ø22xø28x4 mm)	
	10	8A00 93324	2	Anello di tenuta	Seal ring	Bague de retenue	Dichtring	Anillo de retención	
	11	8000 A4431	1	Spinotto D20-d10-L25,2	Gudgeon D20-d10-L25,2	Axe D20-d10-L25,2	Bolzen D20-d10-L25,2	Perno D20-d10-L25,2	
	12	8000 42023	3	Dado	Nut	Ecrou	Mutter	Tuerca	
	13	8A00 93124	1	Vite (M12x121 mm)	Screw (M12x121 mm)	Vis (M12x121 mm)	Schraube (M12x121 mm)	Tornillo (M12x121 mm)	
	14	8000 A4430	1	Cuscinetto sferico (ø20xø26x20 mm)	Bearing (ø20xø26x20 mm)	Roulement (ø20xø26x20 mm)	Lager (ø20xø26x20 mm)	Cojinete (ø20xø26x20 mm)	
	15	8000 01412	2	Ingrassatore	Lubricator	Graisseur	Schmierbüchse	Lubricador	
	16	8000 86137	4	Anello di tenuta (ø26xø34x4 mm)	Seal ring (ø26xø34x4 mm)	Bague de retenue (ø26xø34x4 mm)	Dichtring (ø26xø34x4 mm)	Anillo de retención (ø26xø34x4 mm)	
	17	8D00 62797	1	Vite (M10x47 mm)	Screw (M10x47 mm)	Vis (M10x47 mm)	Schraube (M10x47 mm)	Tornillo (M10x47 mm)	
	18	8000 93124	1	Vite (M12x103 mm)	Screw (M12x103 mm)	Vis (M12x103 mm)	Schraube (M12x103 mm)	Tornillo (M12x103 mm)	
	19	8A00 86138	1	Vite (M12x106 mm)	Screw (M12x106 mm)	Vis (M12x106 mm)	Schraube (M12x106 mm)	Tornillo (M12x106 mm)	

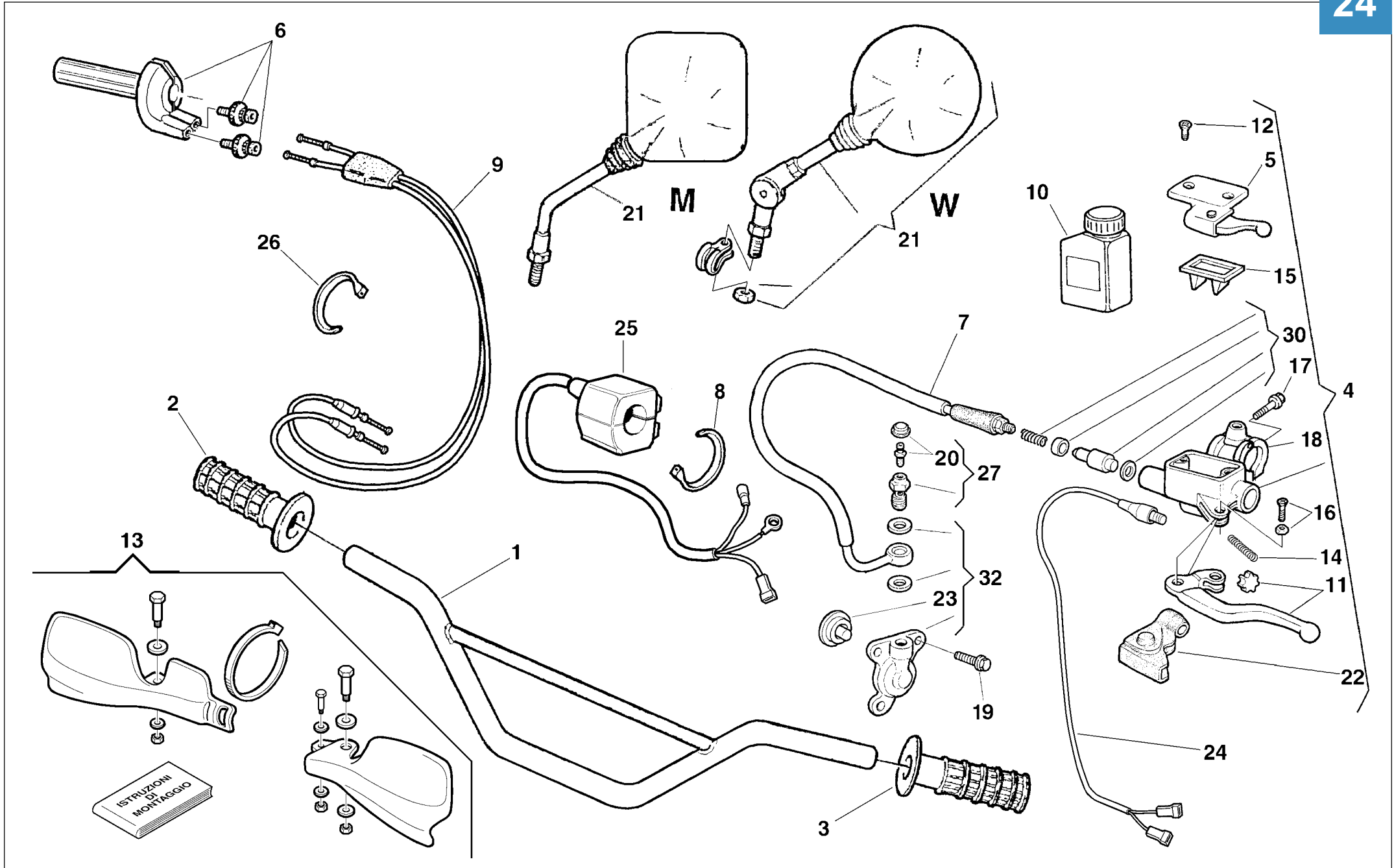



Note Notes Marke Notas	Pos. No. N. Index Pos.	N. Cod. Code No. Nr. Code Code Nr N. Cod.	Q.tà Q.ty Q.te M.ge C.ad	DENOMINAZIONE	NAME	DESIGNATION	BESHREIBUNG	DENOMINACION	Validità Validity Validité Gültig Validez
<b>WM</b>	1	8000 A5506	1	Manubrio	Hanblebar	Guidon	Lenker	Manillar	
<b>C</b>	1	8000 A3612	1	Manubrio	Hanblebar	Guidon	Lenker	Manillar	
	2	8000 76688	1	Manopola Dx.	R.H. grip	Poignée G.	Griff R.	Manopla der.	
	3	8000 76687	1	Manopola Sx.	L.H. grip	Poignée G.	L. Griff	Manopla izrda.	
<b>WM</b>	4	8C00 A2836	1	Ass. pompa comando frizione	Clutch control pump assy	Pompe comm. embrayage	Kupplungspumpe, Kpl.	Bomba mando embrague	
<b>C</b>	4	8B00 A2836	1	Ass. pompa comando frizione	Clutch control pump assy	Pompe comm. embrayage	Kupplungspumpe, Kpl.	Bomba mando embrague	
	5	8000 A2840	1	Coperchietto con leva com. alzavalvole	Cover with valve lifter control lever	Couvercle avec levier comm. dispositif de décompression	Deckel mit Decompressionvor- richtungshebel	Tapa con palanca mando dispositivo decompression	
	6	8000 98209	1	Comando gas completo	Throttle control compl.	Commande gaz compl.	Gasgriff kpl.	Accionam. acelerador compl.	
	7	8000 A2841	1	Tubo mandata olio	Hose	Tuyau	Rohr	Tubo	
	8	8000 50005	1	Fascetta	Clamp	Collier	Schelle	Banda	
	9	8000 A4630	1	Trasmissione comando gas	Throttle wire	Fil comm. gaz	Gaszugkabel	Trans. accionam. acelerador	
	10	8000 A0878	1	Olio frizione	Clutch oil	Huile embrayage	Kupplungsol	Aceite embrague	
	11	8000 A2837	1	Leva frizione	Clutch lever	Levier embrayage	Kupplungshebel	Palanca mando embrague	
	12	8000 A0055	2	Vite	Screw	Vis	Schraube	Tornillo	
<b>W</b>	13	8000 A3612	1	Kit paramani	Hand guards kit	Kit pare-mains	Kit Handschutz	Kit para manos	
	14	8000 A3408	1	Molla	Spring	Ressort	Feder	Resorte	
	15	8000 A0913	1	Diaframma	Diaphragm	Diaphragme	Biegeplatte	Diafragma	
	16	8000 A0877	1	Gruppo vite fiss. leva	Adjuster set	Groupe reglage	Kupplungsreglergruppe	Grupo regul.	
	17	8000 62728	1	Vite	Screw	Vis	Schraube	Tornillo	
<b>WM</b>	18	8A00 A0939	1	Cavallotto	U-bolt	Cavalier	Bügelbolzen	Caballote	
<b>C</b>	18	8000 A0939	1	Cavallotto	U-bolt	Cavalier	Bügelbolzen	Caballote	
	19	8000 62727	3	Vite	Screw	Vis	Schraube	Tornillo	
	20	8000 A3410	1	Valvola di spurgo	Bleeding valve	Soupape de curage	Zangenentleerungsventil	Válvula de purga	
<b>XWD</b>	21	8000 65437	2	Specchietto retrov. Dx. e Sx.	Driving mirror	Rétroviseur	Rückspiegel	Espejo retrovisor	
<b>XMD</b>	21	8B00 68934	1	Specchietto retrov. Dx.	R.H. Driving mirror	Rétroviseur D.	R. Rückspiegel	Espejo retrovisor der.	
<b>XMD</b>	21	8C00 68934	1	Specchietto retrov. Sx.	L.H. Driving mirror	Rétroviseur G.	L. Rückspiegel	Espejo retrovisor iz.	
	22	8000 A0915	1	Protezione leva	Lever guard	Protection levier	Hebelschutz	Proteccion palanca	
	23	8000 A3409	1	Gruppo pistone	Piston	Piston	Kolben	Pistón	
	24	8000 A4457	1	Microinterruttore per comando frizione (250-400)	Clutch control microswitch (250-400)	Microinterrupteur commande embrayage (250-400)	Microschalter für Hebel des Kupplung (250-400)	Microconmutador por mando embrague (250-400)	
<b>WM</b>	25	8000 A2843	1	Commutatore DX compl.	R.H. Switch compl.	Commutateur D. compl.	R. Kombischalter kpl.	Conmutador D. compl.	
	26	8000 71578	4	Fascetta	Clamp	Collier	Schelle	Banda	

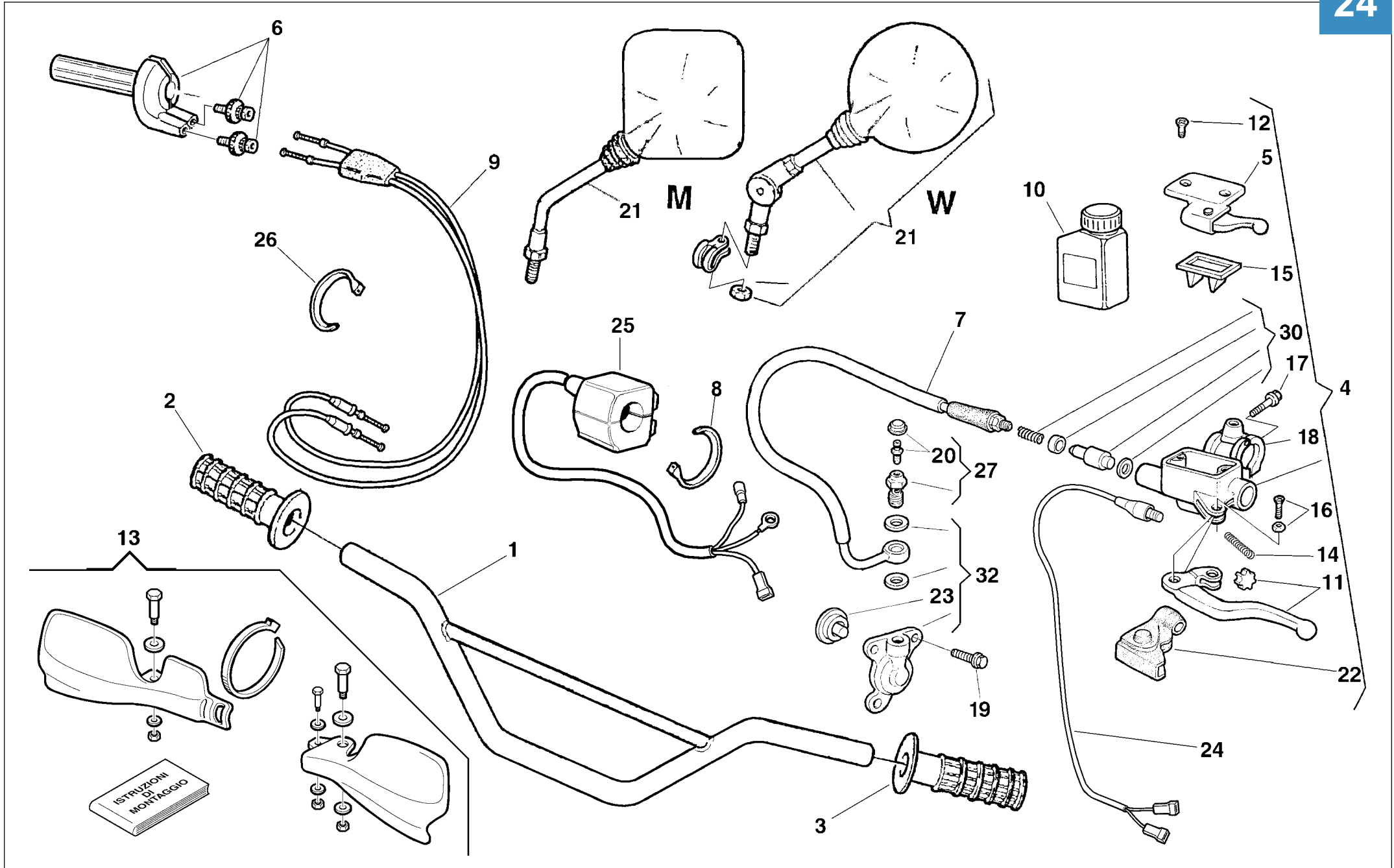



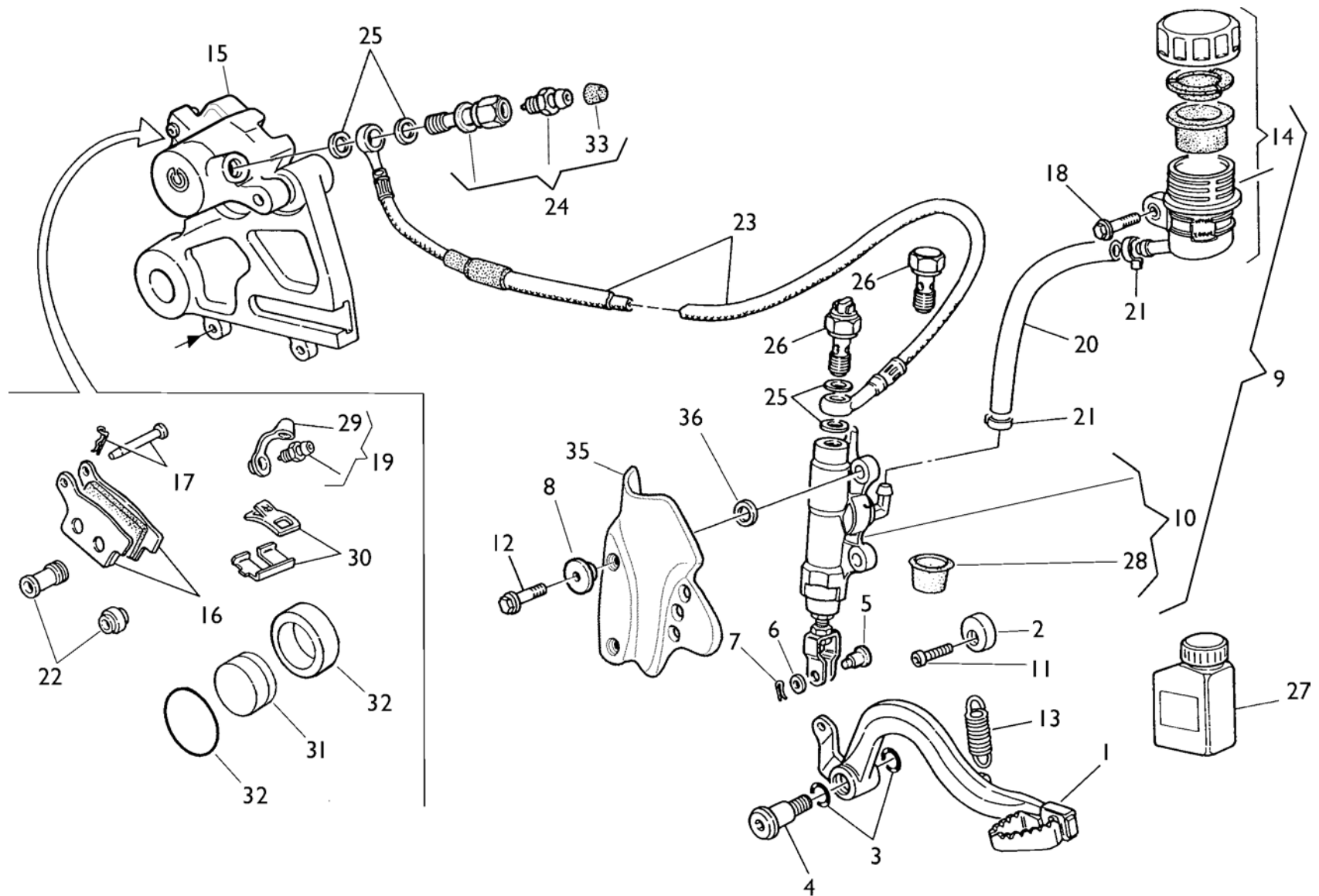

Note Notes Marke Notas	Pos. No. N. Index Pos.	N. Cod. Code No. Nr. Code Code Nr N. Cod.	Q.tà Q.ty Q.te M.ge C.ad	DENOMINAZIONE	NAME	DESIGNATION	BESHREIBUNG	DENOMINACION	Validità Validity Validité Gültig Validez
	1	8000 73894	1	Pedale comando freno	Brake control pedal	Pedal comm. frein	Bremspedal	Pedal accionamiento freno	
	2	8000 69125	1	Camma	Cam	Came	Nocken	Exéntrico	
	3	8000 22551	2	Anello OR	O-Ring	Bague OR	O-Ring	Anillo OR	
	4	8000 55902	1	Vite	Screw	Vis	Schraube	Tornillo	
	5	8000 70696	1	Perno	Pin	Pivot	Bolzen	Perno	
	6	8000 56377	1	Rosetta	Washer	Rondelle	Scheibe	Arandela	
	7	64N1 20068	1	Copiglia	Split pin	Goupille	Splint	Clavija	
<b>WC</b>	8	8A00 66661	2	Distanziale D20-d12-Sp.8,5	Spacer D20-d12-th.8,5	Entretoise D20-d12-ép.8,5	Distanzstück D20-d12-D.8,5	Separadòr D20-d12-esp.8,5	
	9	8A00 76026	1	Pompa comando freno compl.	Brake pump assy	Pompe frein complet	Bremspumpe kl.	Bomba freno compl.	
	10	8000 76338	1	Pompa freno	Brake pump	Pompe frein	Bremspumpe	Bomba freno	
<b>WC</b>	11	8A00 55241	1	Vite	Screw	Vis	Schraube	Tornillo	
<b>M</b>	12	8000 62728	2	Vite	Screw	Vis	Schraube	Tornillo	
	12	8000 62727	2	Vite	Screw	Vis	Schraube	Tornillo	
	13	8000 55903	1	Molla	Spring	Ressort	Feder	Resorte	
	14	8000 61078	1	Serbatoio olio completo	Oil tank assy	Reservoir huile compl.	Öltank Kpl.	Depósito aceite completo	
	15	8000 A4291	1	Pinza freno completa	Brake caliper assy	Pince de frein, compl.	Bremszange, Kpl.	Pinza freno compl.	
	16	8000 A2790	1	Coppia pastiglie	Pads pair	Paire plaquettes	Bremsbelagpaar	Pareja pastillas	
	17	8000 A2791	1	Perno	Pin	Pivot	Bolzen	Perno	
	18	8000 62725	1	Vite	Screw	Vis	Schraube	Tornillo	
	20	8L00 66179	1	Tubazione	Pipe	Tuyau	Rohr	Tubo	
	21	8000 42349	2	Molletta	Spring	Ressort	Feder	Resorte	
	22	8000 79066	1	Cuffie	Boots	Poussiers	haube	Gorro	
	23	8B00 73893	1	Tubo mandata olio	Pipe	Tuyau	Rohr	Tubo	
	24	8000 A3975	1	Vite	Screw	Vis	Schraube	Tornillo	
	25	8000 21480	4	Rosetta	Washer	Rondelle	Scheibe	Arandela	
<b>WM</b>	26	8000 94849	1	Interruttore stop posteriore	Rear stop switch	Interrupteur stop	Stopschalter	Interruptor stop	
<b>C</b>	26	8000 57155	1	Vite	Screw	Vis	Schraube	Tornillo	
<b>R</b>	27	8000 71445	1	Olio freni	Brake oil	Huile de frein	BremsÖl	Aceite freno	
	28	8000 79075	1	Cuffia	Boot	Poussier	haube	Gorro	
	30	8000 A2792	1	Molla-lamierino	Spring-steel clip	Ressort	Feder	Rresorte	
	31	8000 A2793	1	Pistone	Piston	Piston	Kolben	Pistón	
	32	8000 A2794	1	Kit guarnizioni pistone	Kit gasket piston	Kit garniture piston	Kit Kolbendichtung	Kit juntas pistón	
	33	8000 53259	1	Parapolvere	Boots	Para-poudre	Schutzhaube	Para-polvo	

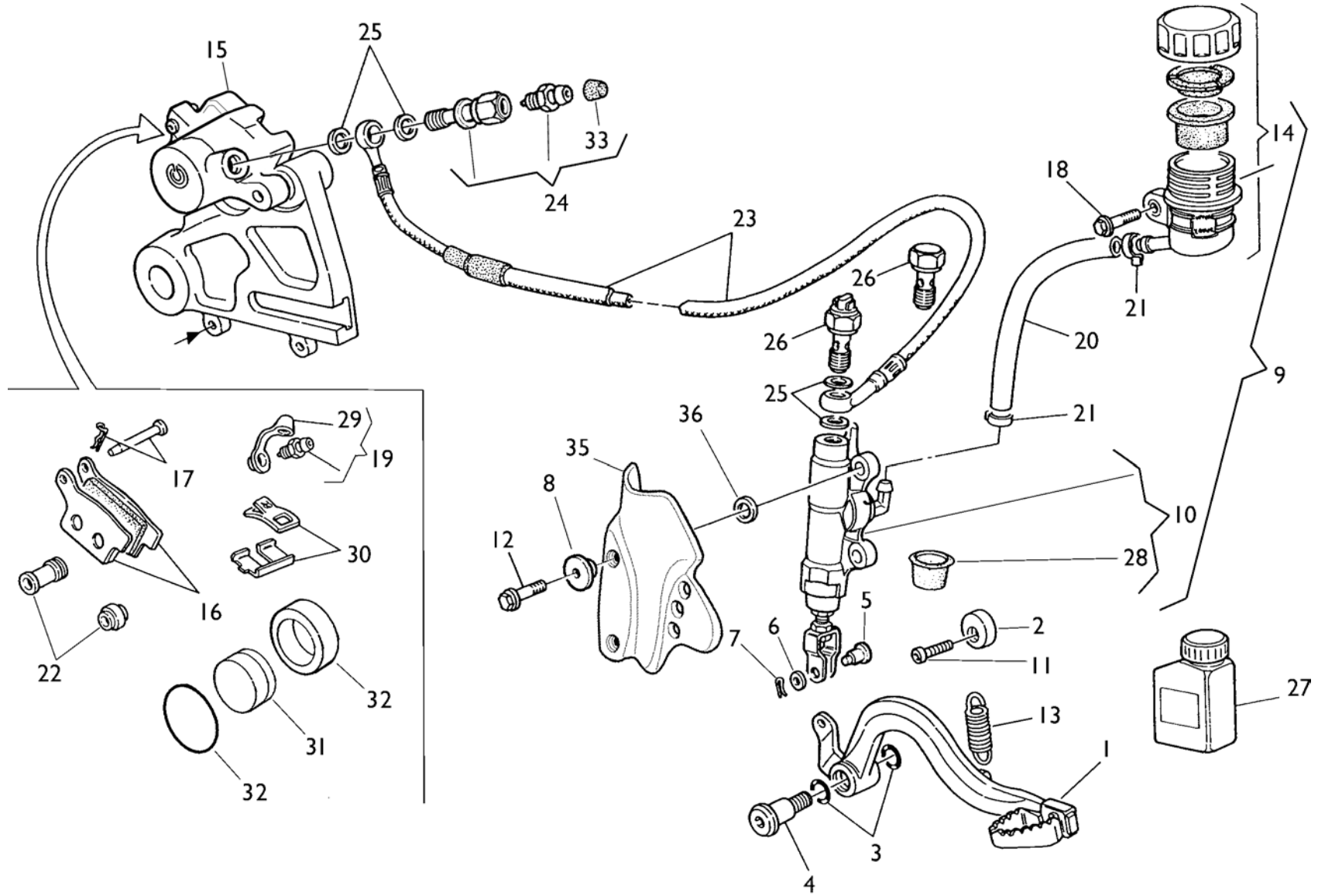





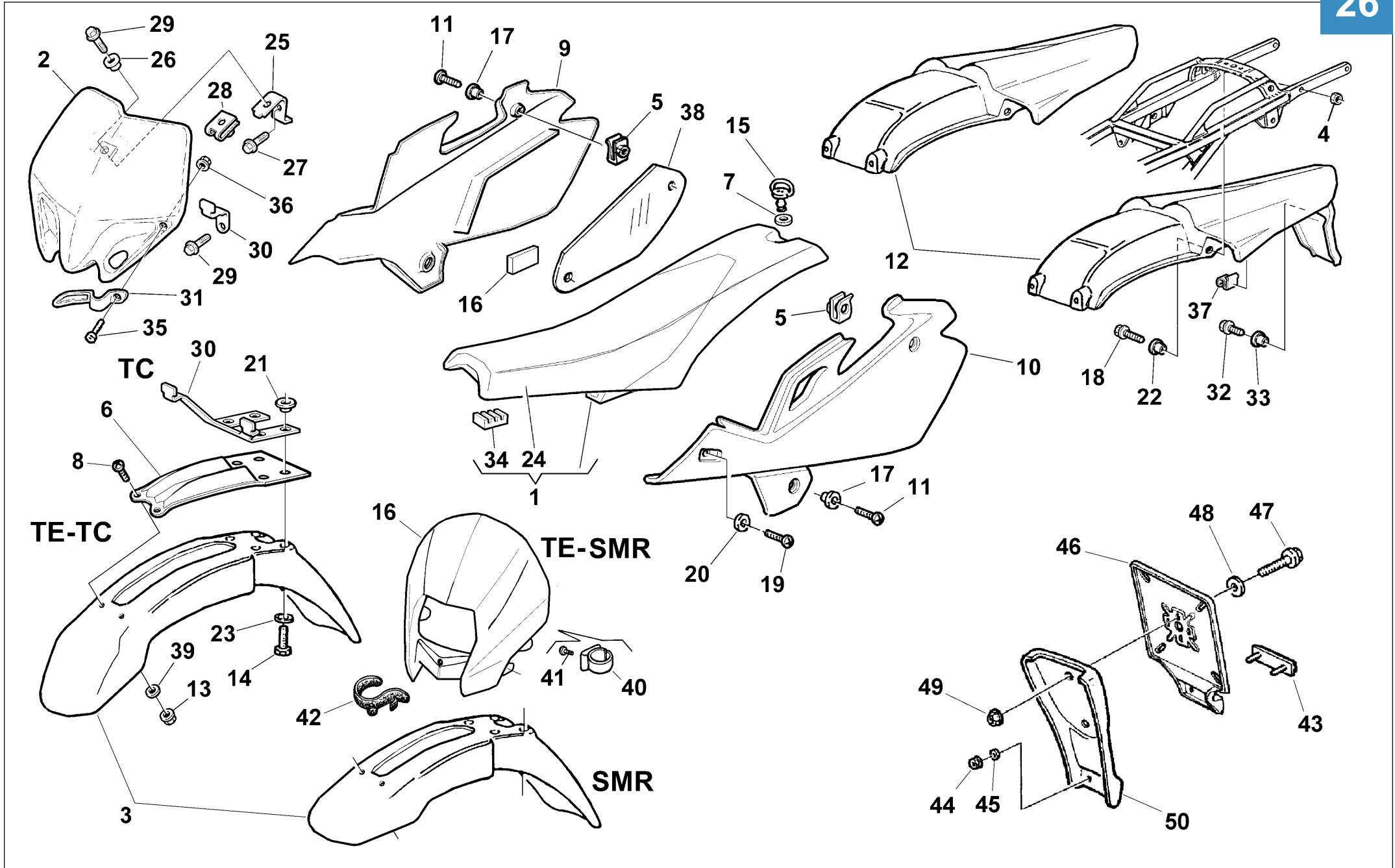

Note Notes Notas	Pos. No. N. Index Pos.	N. Cod. Code No. Nr. Code Code Nr N. Cod.	Q.tà Q.ty Q.te M.ge C.ad	DENOMINAZIONE	NAME	DESIGNATION	BESHREIBUNG	DENOMINACION	Validità Validity Validité Gültig Validez
<b>WC</b>	1	8000 A4306	1	Sella (codice colore E) <b>BLU</b>	Seat (color code E) <b>BLUE</b>	Siège (code couleur E) <b>BLEU</b>	Sattel (Code Farbe E) <b>BLAU</b>	Sillín (còdigo colòr E) <b>AZÚL</b>	
<b>M</b>	1	8B00 A4306	1	Sella (codice colore E) <b>BLU</b>	Seat (color code E) <b>BLUE</b>	Siège (code couleur E) <b>BLEU</b>	Sattel (Code Farbe E) <b>BLAU</b>	Sillín (còdigo colòr E) <b>AZÚL</b>	
<b>M</b>	1	8A00 A4306	1	Sella (co.col.G) <b>Nero+rosso</b>	Seat (col.cod.G) <b>Black+red</b>	Siège (cod.col.G) <b>Noir+rouge</b>	Sattel (Farb.G) <b>Schwarz+Rot</b>	Sillín (còd.col.G) <b>Negro+rojo</b>	
<b>C</b>	2	80A0 A4216	1	Portanumero (codice colore G) <b>Nero</b>	Front number holder (color code G) <b>Black</b>	Portenumero (code couleur G) <b>Noir</b>	Nummerträger (Code Farbe G) <b>Schwarz</b>	Portanumero (còdigo colòr G) <b>Negro</b>	
<b>W</b>	3	8000 A1589	1	Parafango ant. (codice colore E) <b>Giallo</b>	Front mudguard (color code E) <b>Yellow</b>	Garde-boue avant (code couleur E) <b>Jaune</b>	Vord. Kotfluegel (Code Farbe E) <b>Gelb</b>	Guarda-barros del. (còdigo colòr E) <b>Amarillo</b>	
<b>C</b>	3	80B0 A1589	1	Parafango ant. (codice colore G) <b>Bianco</b>	Front mudguard (color code G) <b>White</b>	Garde-boue avant (code couleur G) <b>Blanc</b>	Vord. Kotfluegel (Code Farbe G) <b>Weiss</b>	Guarda-barros del. (còdigo colòr G) <b>Blanco</b>	
<b>M</b>	3	8000 A1761	1	Parafango ant. (codice colore E) <b>Giallo</b>	Front mudguard (color code E) <b>Yellow</b>	Garde-boue avant (code couleur E) <b>Jaune</b>	Vord. Kotfluegel (Code Farbe E) <b>Gelb</b>	Guarda-barros del. (còdigo colòr E) <b>Amarillo</b>	
<b>M</b>	3	80C0 A1761	1	Parafango ant. (codice colore G) <b>Bianco</b>	Front mudguard (color code G) <b>White</b>	Garde-boue avant (code couleur G) <b>Blanc</b>	Vord. Kotfluegel (Code Farbe G) <b>Weiss</b>	Guarda-barros del. (còdigo colòr G) <b>Blanco</b>	
	4	8000 61313	2	Dado	Nut	Ecrou	Mutter	Tuerca	
	5	8000 46893	2	Dado	Nut	Ecrou	Mutter	Tuerca	
	6	8000 A4198	1	Rinforzo per parafango	Fender holder	Soutie pour garde-boue	Kotfluegelsupport	Soporte por guardabarros del.	
	7	8000 69149	1	Rosetta elastica	Spring washer	Rondelle élastique	Federscheibe	Arandela elástica	
	8	80A0 65535	2	Vite	Screw	Vis	Schraube	Tornillo	
<b>WM</b>	9	8000 A4220	1	Pannello destro (codice colore E) <b>Giallo</b>	R.H. panel (color code E) <b>Yellow</b>	Panneau, D. (code couleur E) <b>Jaune</b>	Streifen. R. (Code Farbe E) <b>Gelb</b>	Panel Der. (còdigo colòr E) <b>Amarillo</b>	
<b>M</b>	9	80C0 A4220	1	Pannello destro (codice colore G) <b>Nero</b>	R.H. panel (color code G) <b>Black</b>	Panneau, D. (code couleur G) <b>Noir</b>	Streifen. R. (Code Farbe G) <b>Schwarz</b>	Panel Der. (còdigo colòr G) <b>Negro</b>	
<b>WM</b>	10	8000 A4219	1	Pannello sinistro (codice colore E) <b>Giallo</b>	L.H. panel (color code E) <b>Yellow</b>	Panneau, G. (code couleur E) <b>Jaune</b>	Streifen. L. (Code Farbe E) <b>Gelb</b>	Panel Izq. (còdigo colòr E) <b>Amarillo</b>	
<b>M</b>	10	80C0 A4219	1	Pannello sinistro (codice colore G) <b>Nero</b>	L.H. panel (color code G) <b>Black</b>	Panneau, G. (code couleur G) <b>Noir</b>	Streifen. L. (Code Farbe G) <b>Schwarz</b>	Panel Izq. (còdigo colòr G) <b>Negro</b>	
	11	8000 62728	4	Vite	Screw	Vis	Schraube	Tornillo	
<b>WM</b>	12	8000 A4214	1	Parafango post. (codice colore E) <b>Giallo</b>	Rear mudguard (color code E) <b>Yellow</b>	Garde-boue arriere (code couleur E) <b>Jaune</b>	Hint. Kotfluegel (Code Farbe E) <b>Gelb</b>	Guarda-barros tras. (còdigo colòr E) <b>Amarillo</b>	
<b>M</b>	12	80C0 A4214	1	Parafango post. (codice colore G) <b>Bianco</b>	Rear mudguard (color code G) <b>White</b>	Garde-boue arriere (code couleur G) <b>Blanc</b>	Hint. Kotfluegel (Code Farbe G) <b>Weiss</b>	Guarda-barros tras. (còdigo colòr G) <b>Blanco</b>	
<b>C</b>	12	80C0 A4200	1	Parafango post. (codice colore B) <b>Nero</b>	Rear mudguard (color code B) <b>Black</b>	Garde-boue arriere (code couleur B) <b>Noir</b>	Hint. Kotfluegel (Code Farbe B) <b>Schwarz</b>	Guarda-barros tras. (còdigo colòr B) <b>Negro</b>	

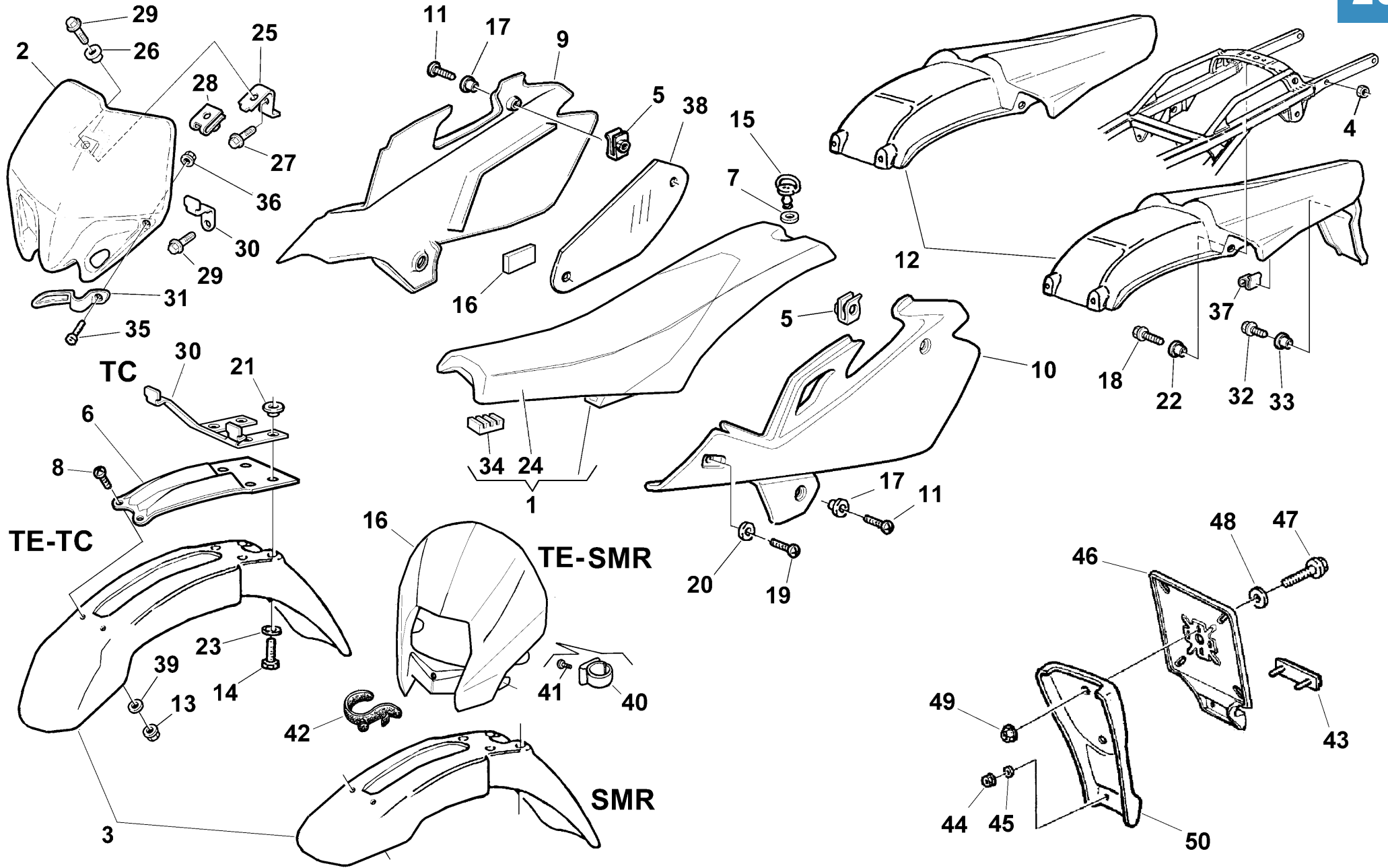

Note Notes Marke Notas	Pos. No. N. Index Pos.	N. Cod. Code No. Nr. Code Code Nr N. Cod.	Q.tà Q.ty Q.te M.ge C.ad	DENOMINAZIONE	NAME	DESIGNATION	BESHREIBUNG	DENOMINACION	Validità Validity Validité Gültig Validez
	13	8000 61355	2	Dado	Nut	Ecrou	Mutter	Tuerca	
	14	8000 62728	4	Vite	Screw	Vis	Schraube	Tornillo	
	15	8000 69148	1	Perno	Pin	Pivot	Bolzen	Perno	
<b>WM</b>	16	80B0 A4206	1	Cupolino	Front fairing	Carenage	Verkleidung	Cùpula	
				(codice colore E) <b>BLU</b>	(color code E) <b>BLUE</b>	(code couleur E) <b>BLEU</b>	(Code Farbe E) <b>BLAU</b>	(còdigo colòr E) <b>AZÚL</b>	
<b>M</b>	16	80A0 A4206	1	Cupolino	Front fairing	Carenage	Verkleidung	Cùpula	
				(codice colore G) <b>Nero</b>	(color code G) <b>Black</b>	(code couleur G) <b>Noir</b>	(Code Farbe G) <b>Schwarz</b>	(còdigo colòr G) <b>Negro</b>	
	17	8000 69429	4	Boccola	Bushing	Douille	Buchse	Casquillo	
	18	8000 62728	2	Vite (M6x20mm)	Screw (M6x20mm)	Vis (M6x20mm)	Schraube (M6x20mm)	Tornillo (M6x20mm)	
	19	8000 62727	2	Vite	Screw	Vis	Schraube	Tornillo	
	20	8000 69429	2	Bussola	Bushing	Douille	Buchse	Manguito	
	21	8C00 69429	4	Bussola	Bushing	Douille	Buchse	Manguito	
	22	8000 69429	2	Bussola	Bushing	Douille	Buchse	Manguito	
	23	8000 48814	4	Rosetta	Washer	Rondelle	Scheibe	Arandela	
	24	8000 A4305	1	Rivestimento sella	Saddle covering	Revetement selle	Sattelverkleidung	Revestimiento sillin	
				(codice colore E) <b>BLU</b>	(color code E) <b>BLUE</b>	(code couleur E) <b>BLEU</b>	(Code Farbe E) <b>BLAU</b>	(còdigo colòr E) <b>AZÚL</b>	
<b>M</b>	24	8A00 A4305	1	Rivestimento sella	Saddle covering	Revetement selle	Sattelverkleidung	Revestimiento sillin	
				(codice colore G) <b>Nero+rosso</b>	(color code G) <b>Black+red</b>	(code couleur G) <b>NOIR+rouge</b>	(Code Farbe G) <b>Schwarz+Rot</b>	(còdigo colòr G) <b>Negro+rojo</b>	
<b>C</b>	25	8000 A4609	1	Piastrina	Plate	Plaquette	Platte	Placa	
<b>C</b>	26	8000 69429	1	Bussola	Bushing	Douille	Buchse	Manguito	
<b>C</b>	27	8E00 67997	1	Vite	Screw	Vis	Schraube	Tornillo	
<b>C</b>	28	8000 46893	1	Dado	Nut	Ecrou	Mutter	Tuerca	
	29	8000 62726	3	Vite (TC 250)	Screw (TC 250)	Vis (TC 250)	Schraube (TC 250)	Tornillo (TC 250)	
	29	8000 62726	1	Vite (TC 450-510)	Screw (TC 450-510)	Vis (TC 450-510)	Schraube (TC 450-510)	Tornillo (TC 450-510)	
	30	8000 A4607	2	Attacco portanumero (TC 250)	Spacer (TC 250)	Entretoise (TC 250)	Distanzstück (TC 250)	Separadòr (TC 250)	
	30	8000 A6644	1	Attacco portanumero (TC 450-510)	Spacer (TC 450-510)	Entretoise (TC 450-510)	Distanzstück (TC 450-510)	Separadòr (TC 450-510)	
<b>C</b>	31	8000 A4610	1	Guidafile	Cable guide	Passe-cable	Kabelführung	Prensa-cable	
	34	8661 0191A	2	Tampone appoggio sella	Pad	Tampon	Stopfen	Tampòn	
<b>C</b>	35	8000 62728	1	Vite	Screw	Vis	Schraube	Tornillo	
<b>WM</b>	37	8000 72494	1	Molletta fiss. cavo ind. post. dx	Spring	Ressort	Feder	Muelle	
	38	8000 A4875	1	Protezione	Guard	Protection	Schutz	Protección	
	39	62N1 15548	2	Rosetta	Washer	Rondelle	Scheibe	Arandela	

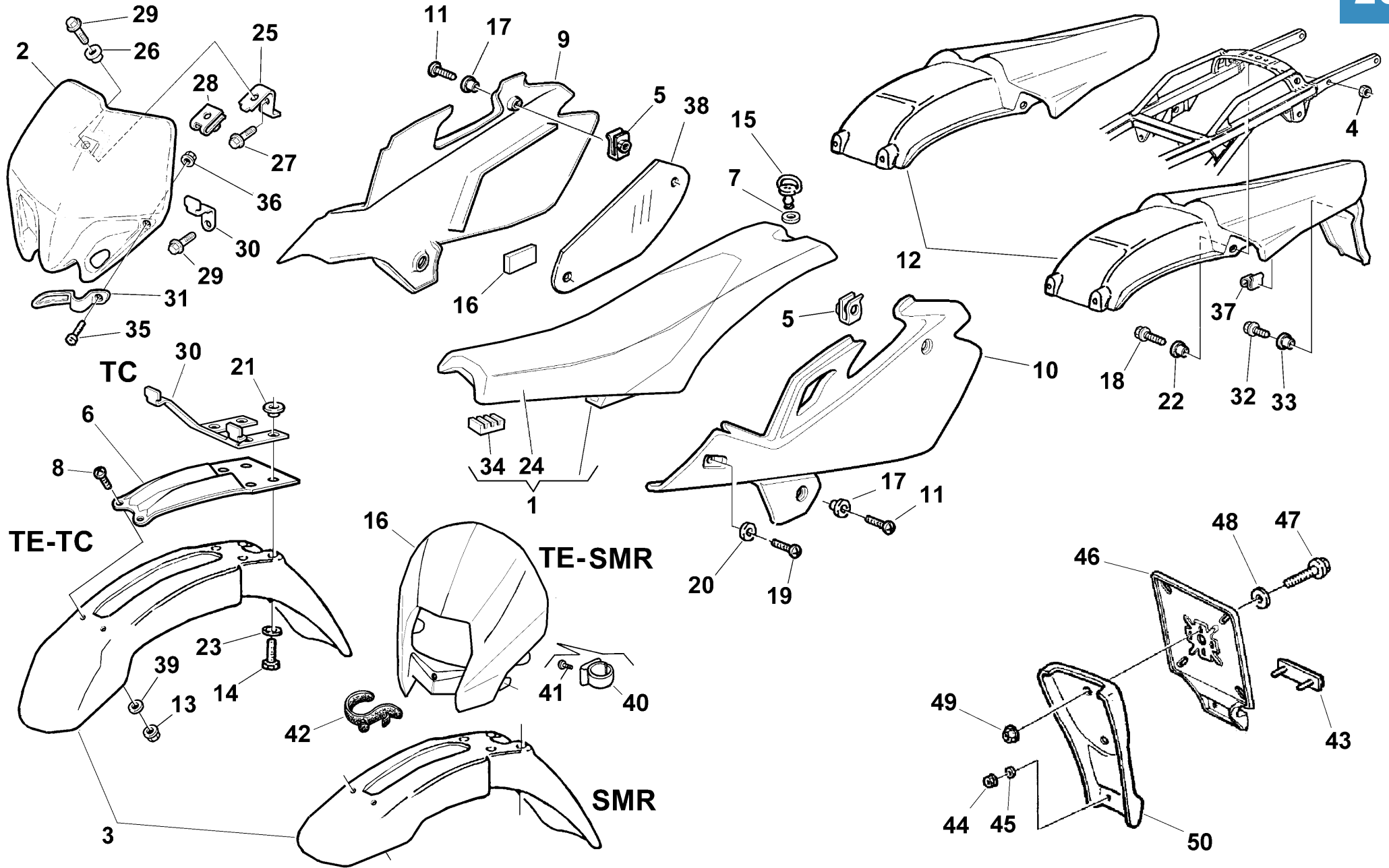



Note Notes Notas	Pos. No. Index Pos.	N. Cod. Code No. Nr. Code Code Nr N. Cod.	Q.tà Q.ty Q.te M.ge C.ad	DENOMINAZIONE	NAME	DESIGNATION	BESHREIBUNG	DENOMINACION	Validità Validity Validité Gültig Validez
<b>WM</b>	40	8000 A0864	1	Anello	Ring	Anneau	Ring	Anillo	
<b>WM</b>	41	8A00 37283	2	Vite	Screw	Vis	Schraube	Tornillo	
	42	8000 88602	4	Elastico (TE 250)	Elastic band	Elastique	Elastisch	Elástico	
	42	8000 A4080	4	Elastico (SMR, TE 450-510)	Elastic band (SMR, TE 450-510)	Elastique (SMR, TE 450-510)	Elastisch (SMR, TE 450-510)	Elástico (SMR, TE 450-510)	
<b>WM</b>	43	8000 73834	1	Catadiottro	Reflector	Catadioptrique	Ruckstrahler	Catafaros	
<b>WM</b>	44	8000 40717	2	Dado	Nut	Ecrou	Mutter	Tuerca	
<b>WM</b>	45	62N1 15547	2	Rosetta	Washer	Rondelle	Scheibe	Arandela	
<b>WM</b>	46	8000 94595	1	Portatarga	Licence plate holder	Portebalai	Schildträger	Portamaticula	
<b>WM</b>	47	8000 62727	2	Vite	Screw	Vis	Schraube	Tornillo	
<b>WM</b>	48	8000 56359	2	Vite	Screw	Vis	Schraube	Tornillo	
<b>WM</b>	49	8000 44240	2	Dado	Nut	Ecrou	Mutter	Tuerca	
<b>R</b>	50	8000 94342	1	Paraspruzzi (TE, SMR 450-510)	Rear end (TE, SMR 450-510)	Terminal (TE, SMR 450-510)	Hinterkiff (TE, SMR 450-510)	Para rociada (TE, SMR 450-510)	

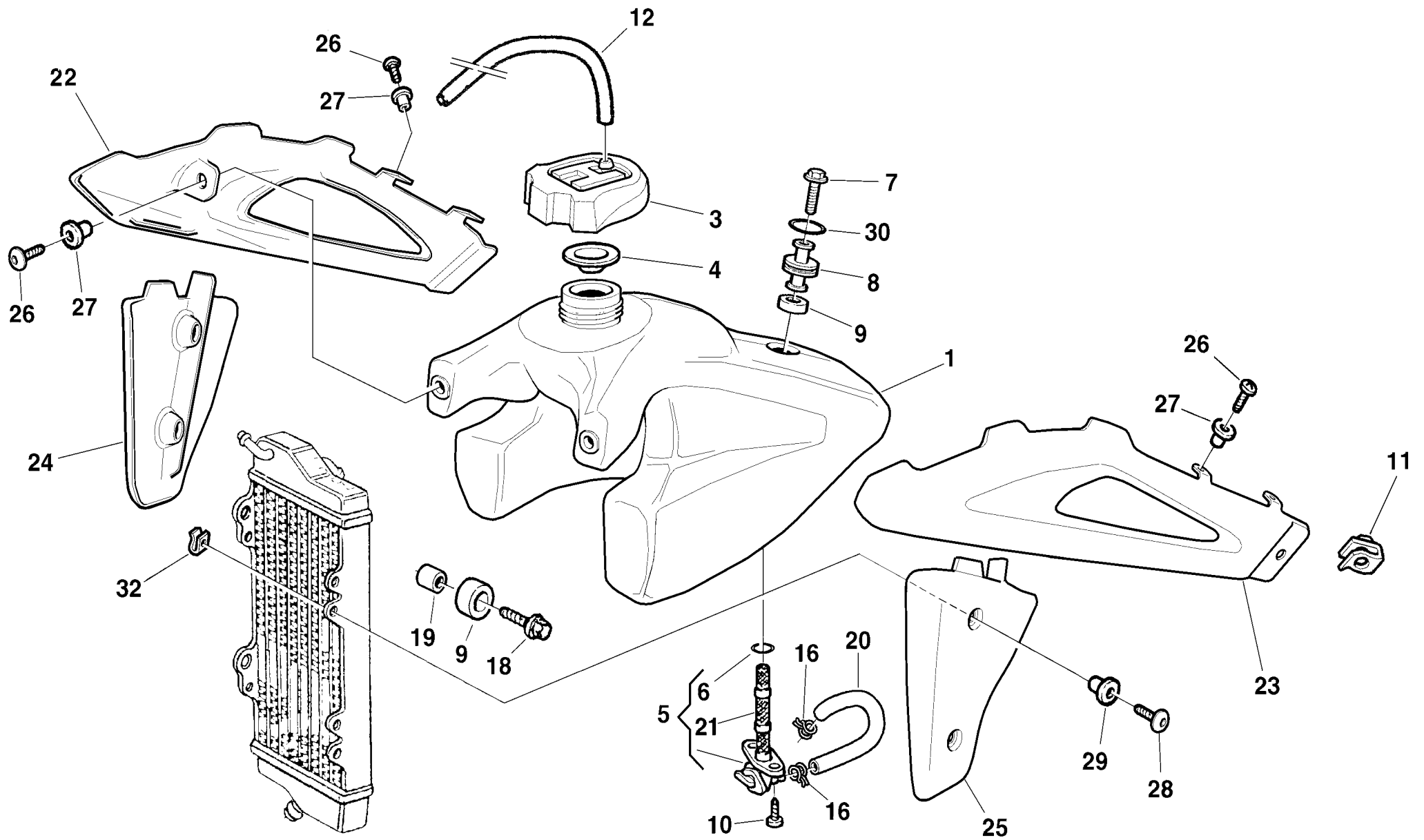

Note Notes Notes Marka Notas	Pos. No. N. Index Pos.	N. Cod. Code No. Nr. Code Code Nr N. Cod.	Q.tà Q.ty Q.te M.ge C.ad	DENOMINAZIONE	NAME	DESIGNATION	BESHREIBUNG	DENOMINACION	Validità Validity Validité Gültig Validez
	1	8000 A4275	1	Serbatoio carburante (l 10,5)	Fuel tank (l 10,5)	Réservoir essence (l 10,5)	Kraftstoffbehälter (l 10,5)	Depósito gasolina (l 10,5)	
	3	8000 A4563	1	Tappo	Plug	Bouchon	Verschluss	Tapón	
	4	8000 A4562	1	Guarnizione	Gasket	Garniture	Dichtung	Junta	
	5	8000 43592	1	Rubinetto benzina	Cock	Robinet	Kraftstoffahn	Grifo gasolina	
	6	8000 01199	1	Anello OR	O-Ring	Bague OR	O-Ring	Anillo OR	
	7	8B00 67545	1	Vite (M6x55 mm)	Screw (M6x55 mm)	Vis (M6x55 mm)	Schraube (M6x55 mm)	Tornillo (M6x55 mm)	
	8	8B00 A0702	1	Distanziale (46mm)	Spacer (46mm)	Entretoise (46 mm)	Distanzstück (46 mm)	Separador (46 mm)	
	9	8000 A0528	3	Tampone	Pad	Tampon	Stopfen	Tampón	
	10	8000 37745	2	Vite	Screw	Vis	Schraube	Tornillo	
	11	8000 46893	2	Dado	Nut	Ecrou	Mutter	Tuerca	
	12	8T00 68873	1	Condotto benzina (L=300 mm)	Pipe (L=300 mm)	Tuyau (L=300 mm)	Rohr (L=300 mm)	Tube (L=300 mm)	
	16	80A0 42349	2	Fascetta	Clamp	Collier	Schelle	Banda	
	18	60N1 02510	2	Vite	Screw	Vis	Schraube	Tornillo	
	19	8000 A0680	2	Distanziale	Spacer	Entretoise	Distanzstück	Separador	
	20	8D00 94010	1	Condotto benzina (L=135 mm)	Pipe (L=135 mm)	Tuyau (L=135 mm)	Rohr (L=135 mm)	Tube (L=135 mm)	
	21	8000 38748	1	Filtro benzina	Fuel filter	Filtre à essence	Benzinfilter	Filtro gasolina	
<b>WM</b>	22	80B0 A4236	1	Convogliatore Dx (250-450-510) (codice colore E) <b>BLU</b>	R. side panel (250-450-510) (color code E) <b>BLUE</b>	Flanc D. (250-450-510) (code couleur E) <b>BLEU</b>	Flanke R. (250-450-510) (Code Farbe E) <b>BLAU</b>	Lateral D. (250-450-510) (còdigo colòr E) <b>AZÚL</b>	
<b>CM</b>	22	80D0 A4236	1	Convogliatore DX (450-510) (codice colore G) <b>Rosso</b>	R. side panel (450-510) (color code G) <b>Red</b>	Flanc D. (450-510) (code couleur G) <b>Rouge</b>	Flanke R. (450-510) (Code Farbe G) <b>Rot</b>	Lateral D. (450-510) (còdigo colòr G) <b>Rojo</b>	
<b>WM</b>	23	80B0 A4235	1	Convogliatore Sx (250-450-510) (codice colore E) <b>BLU</b>	L. side panel (250-450-510) (color code E) <b>BLUE</b>	Flanc G. (250-450-510) (code couleur E) <b>BLEU</b>	Flanke L. (250-450-510) (Code Farbe E) <b>BLAU</b>	Lateral I. (250-450-510) (còdigo colòr E) <b>AZÚL</b>	
<b>CM</b>	23	80D0 A4235	1	Convogliatore SX (450-510) (codice colore G) <b>Rosso</b>	L. side panel (450-510) (color code G) <b>Red</b>	Flanc G. (450-510) (code couleur G) <b>Rouge</b>	Flanke L. (450-510) (Code Farbe G) <b>Rot</b>	Lateral I. (450-510) (còdigo colòr G) <b>Rojo</b>	
	24	8000 A4844	1	Protezione Dx	R.H. protection	Protection D.	Schutz Rechte	Protección der.	
	25	8000 A4845	1	Protezione Sx	L.H. protection	Protection G.	Schutz Linke	Protección izquierda	
	26	80C0 55699	8	Vite M6-L10	Screw M6-L10	Vis M6-L10	Schraube M6-L10	Tornillo M6-L10	
	27	8000 45495	8	Bussola	Bushing	Douille	Buchse	Manguito	
	28	8000 62727	4	Vite (M6x16 mm)	Screw (M6x16 mm)	Vis (M6x16 mm)	Schraube (M6x16 mm)	Tornillo (M6x16 mm)	
	29	8000 69429	4	Bussola	Bushing	Douille	Buchse	Manguito	
	30	8000 28929	2	Anello OR	O-Ring	Bague OR	O-Ring	Anillo OR	
	32	8000 60873	4	Dado a graffetta	Nut	Ecrou	Mutter	Tuerca	

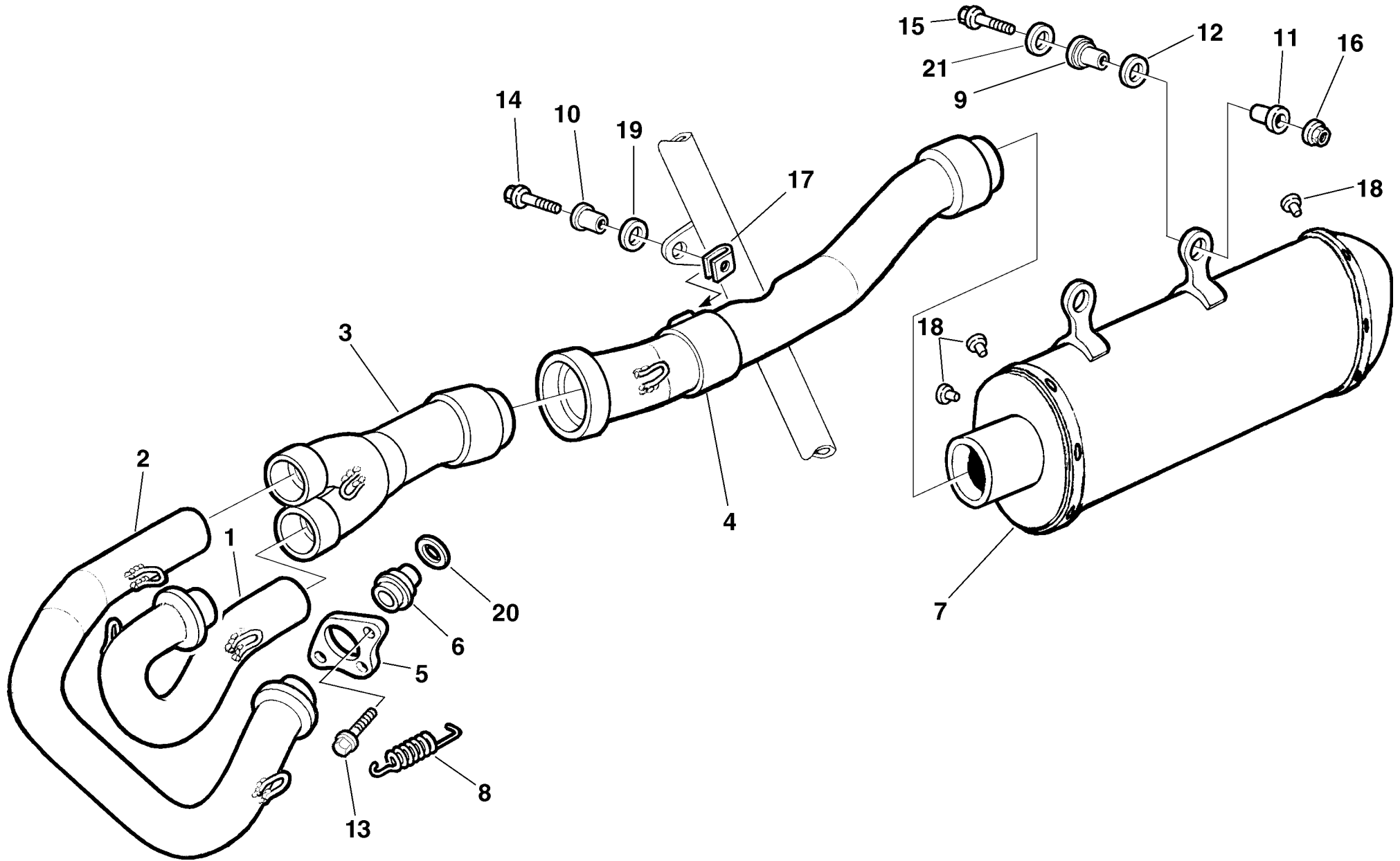

Note Notes Notas	Pos. No. N. Index Pos.	N. Cod. Code No. Nr. Code Code Nr N. Cod.	Q.tà Q.ty Q.te M.ge C.ad	DENOMINAZIONE	NAME	DESIGNATION	BESHREIBUNG	DENOMINACION	Validità Validity Validité Gültig Validez
<b>WM</b>	1	8000 A6126	1	Tubo di scarico Dx	R.H. exhaust pipe	Tuyau d'échapp. D.	Auspuffrohr R.	Tubo de escape der.	
<b>C</b>	1	8000 A6130	1	Tubo di scarico Dx	R.H. exhaust pipe	Tuyau d'échapp. D.	Auspuffrohr R.	Tubo de escape der.	
<b>WM</b>	2	8000 A6125	1	Tubo di scarico Sx	L.H. exhaust pipe	Tuyau d'échapp. G.	Auspuffrohr L.	Tubo de escape izq.	
<b>C</b>	2	8000 A6129	1	Tubo di scarico Sx	L.H. exhaust pipe	Tuyau d'échapp. G.	Auspuffrohr L.	Tubo de escape izq.	
	3	8000 A6240	1	Raccordo anteriore (TE 250)	Front union (TE 250)	Raccord avant (TE 250)	Anschluss (TE 250)	Empalme (TE 250)	
	3	8000 A6485	1	Raccordo anteriore (TC 250)	Front union (TC 250)	Raccord avant (TC 250)	Anschluss (TC 250)	Empalme (TC 250)	
	3	8000 A6486	1	Raccordo anteriore (TC 450-510)	Front union (TC 450-510)	Raccord avant (TC 450)	Anschluss (TC 450-510)	Empalme (TC 450-510)	
	3	8000 A6241	1	Raccordo anteriore (TE- 450-510, SMR)	Front union (TE- 450-510, SMR)	Raccord avant (TE- 450-510, SMR)	Anschluss (TE- 450-510, SMR)	Empalme (TE- 450-510, SMR)	
	4	8000 A6127	1	Raccordo (TE 250)	Union (TE 250)	Raccord (TE 250)	Anschluss (TE 250)	Empalme (TE 250)	
	4	8000 A6131	1	Raccordo (TC 250)	Union (TC 250)	Raccord (TC 250)	Anschluss (TC 250)	Empalme (TC 250)	
	4	8000 A6137	1	Raccordo (TC 450-510)	Union (TC 450-510)	Raccord (TC 450)	Anschluss (TC 450-510)	Empalme (TC 450-510)	
	4	8000 A6128	1	Raccordo (TE- 450-510, SMR)	Union (TE- 450-510, SMR)	Raccord (TE- 450-510, SMR)	Anschluss (TE- 450-510, SMR)	Empalme (TE- 450-510, SMR)	
	5	8000 A0870	2	Flangia	Flange	Bride	Flansch	Brida	
	6	8000 A0871	2	Bussola (250)	Bushing (250)	Douille (250)	Buchse (250)	Manguito (250)	
	6	8000 A0893	2	Bussola (400-450-510)	Bushing (400-450-510)	Douille (400-450-510)	Buchse (400-450-510)	Manguito (400-450-510)	
	7	8000 A6121	1	Silenziatore (TE 250)	Exhaust silencer (TE 250)	Silencieux d'échapp. (TE 250)	Schalldämpfer (TE 250)	Silenciador de esc. (TE 250)	
	7	8000 A6132	1	Silenziatore (TC 250)	Exhaust silencer (TC 250)	Silencieux d'échapp. (TC 250)	Schalldämpfer (TC 250)	Silenciador de esc. (TC 250)	
	7	8000 A6136	1	Silenziatore (TC 250) (USA-CDN)	Exhaust silencer (TC 250) (USA-CDN)	Silencieux d'échapp. (TC 250) (USA-CDN)	Schalldämpfer (TC 250) (USA-CDN)	Silenciador de esc. (TC 250) (USA-CDN)	
	7	8000 A6122	1	Silenziatore (TE 450-510, SMR)	Exhaust silencer (TE 450-510, SMR)	Silencieux d'échapp. (TE 450-510, SMR)	Schalldämpfer (TE 450-510, SMR)	Silenciador de esc. (TE 450-510, SMR)	
	7	8000 A6138	1	Silenziatore (TC 450-510)	Exhaust silencer (TC 450-510)	Silenc. d'échapp. (TC 450-510)	Schalldämpfer (TC 450-510)	Silenc. de esc. (TC 450-510)	
	7	8000 A6139	1	Silenziatore (TC 450-510) (USA-CDN)	Exhaust silencer (TC 450-510) (USA-CDN)	Silenc. d'échapp. (TC 450-510) (USA-CDN)	Schalldämpfer (TC 450-510) (USA-CDN)	Silenc. de esc. (TC 450-510) (USA-CDN)	
	8	8000 A1239	6	Molla	Spring	Ressort	Feder	Resorte	
	9	8M00 70379	2	Distanziale	Spacer	Entretoise	Distanzstück	Separador	
<b>WC</b>	10	8000 A0414	1	Distanziale	Spacer	Entretoise	Distanzstück	Separador	
	11	1514 03203	2	Rosetta in gomma	Rubber washer	Rondelle en caoutchouc	Gummischeibe	Arandela de goma	
	12	1513 41401	2	Rosetta in gomma	Rubber washer	Rondelle en caoutchouc	Gummischeibe	Arandela de goma	

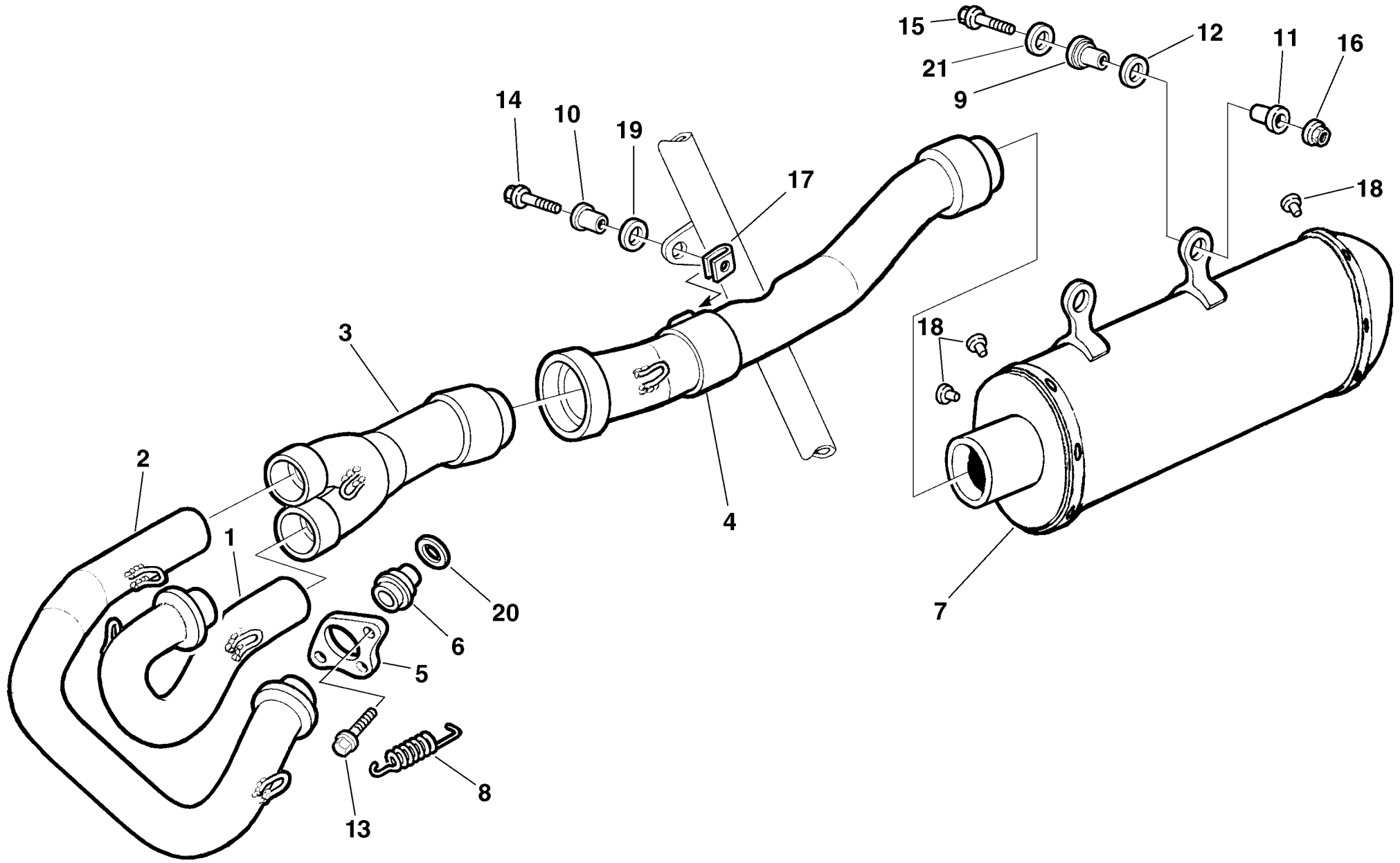



Note Notes Marke Notas	Pos. No. N. Index Pos.	N. Cod. Code No. Nr. Code Code Nr N. Cod.	Q.tà Q.ty Q.te M.ge C.ad	DENOMINAZIONE	NAME	DESIGNATION	BESHREIBUNG	DENOMINACION	Validità Validity Validité Gültig Validez
	13	8000 62726	4	Vite (M6x14 mm)	Screw (M6x14 mm)	Vis (M6x14 mm)	Schraube (M6x14 mm)	Tornillo (M6x14 mm)	
	14	8000 62727	1	Vite (M6x16 mm)	Screw (M6x16 mm)	Vis (M6x16 mm)	Schraube (M6x16 mm)	Tornillo (M6x16 mm)	
	15	8B00 67545	2	Vite (M6x45 mm)	Screw (M6x45 mm)	Vis (M6x45 mm)	Schraube (M6x45 mm)	Tornillo (M6x45 mm)	
	16	8000 44240	2	Dado	Nut	Ecrou	Mutter	Tuerca	
	17	8000 46893	1	Dado a graffetta	Nut	Ecrou	Mutter	Tuerca	
	18	8000 48802	2	Gommino	Rubber pad	Pièce caoutchouc	Gummistück	Junta de goma	
	19	8000 A1353	1	Gommino	Rubber pad	Pièce caoutchouc	Gummistück	Junta de goma	
	20	8000 A0873	2	Guarnizione (250)	Gasket (250)	Garnitue (250)	Dichtung (250)	Junta (250)	
	20	8A00 A0873	2	Guarnizione (400-45-510)	Gasket (400-45-510)	Garnitue (400-45-510)	Dichtung (400-45-510)	Junta (400-45-510)	
	21	8000 30319	2	Rosetta	Washer	Rondelle	Scheibe	Arandela	

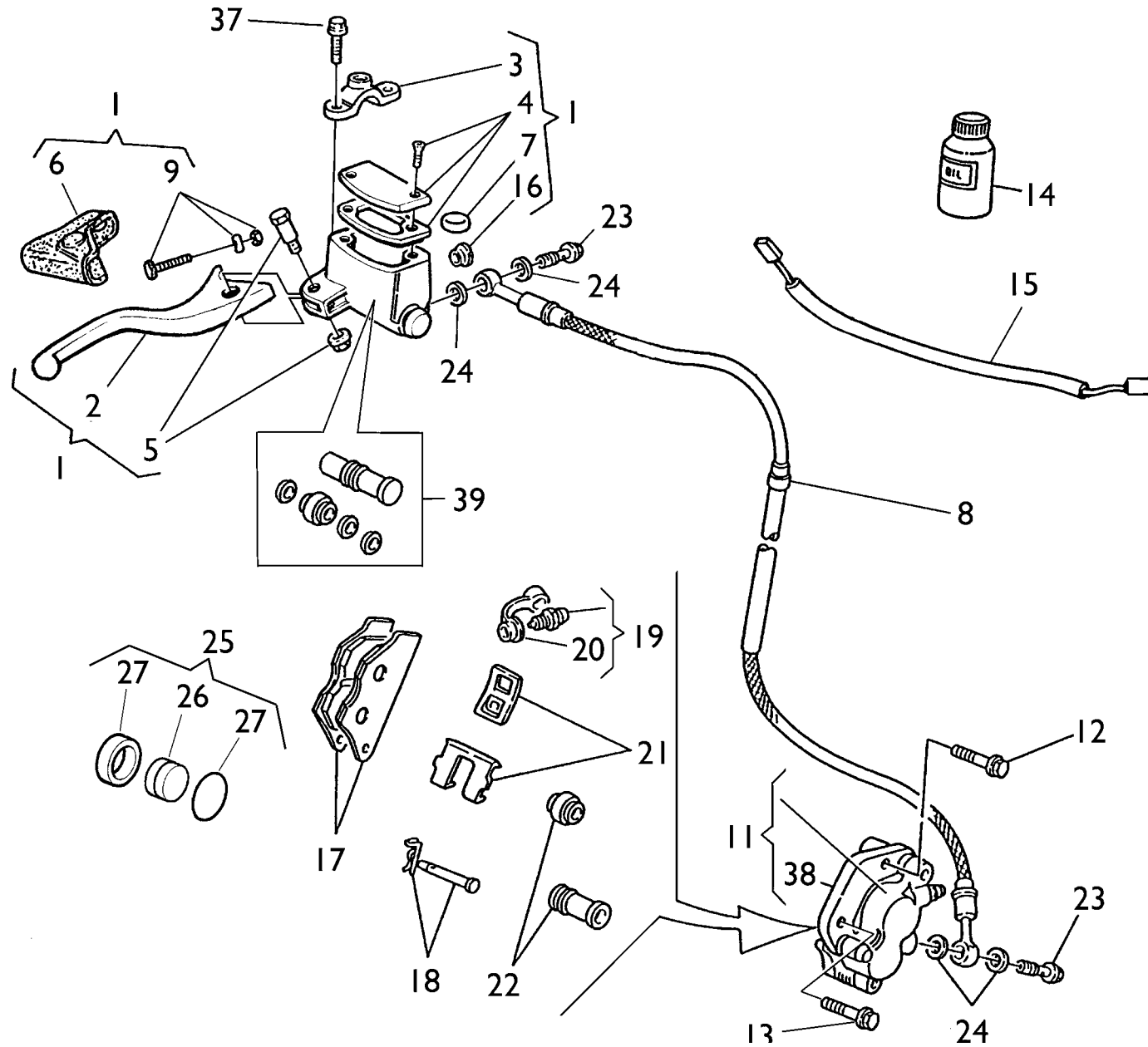

Note Notes Notes Marka Notas	Pos. No. N. Index Pos.	N. Cod. Code No. Nr. Code Code Nr N. Cod.	Q.tà Q.ty Q.te M.ge C.ad	DENOMINAZIONE	NAME	DESIGNATION	BESHREIBUNG	DENOMINACION	Validità Validity Validité Gültig Validez
<b>W</b>	1	8000 A4552	1	Pompa comando freno ant.	Brake pump	Pompe frein	Bremspumpe	Bomba freno	
<b>C</b>	1	8000 A4495	1	Pompa comando freno ant.	Brake pump	Pompe frein	Bremspumpe	Bomba freno	
	2	8000 A4564	1	Leva	Lever	Levier	Hebel	Palanca	
<b>W</b>	3	8000 A4568	1	Cavallotto	U-bolt	Cavalier	Bügelbolzen	Caballate	
<b>C</b>	3	8000 A4565	1	Cavallotto	U-bolt	Cavalier	Bügelbolzen	Caballate	
	4	8000 94126	1	Kit tappo	Plug kit	Bouchon kit	Verschluss Gruppe	Kit tapón	
	5	8000 94127	1	Perno	Pin	Pivot	Bolzen	Perno	
	6	8000 94128	1	Cappuccio	Cap	Capuchon	Kappe	Capuchon	
	7	8000 79099	1	Antiemulsione	Antiemulsion	Antiemulsion	Eulsionwidriger	Antiemulsion	
<b>W</b>	8	8000 A6242	1	Tubo mandata olio	Hose	Tuyau	Rohr	Tubo	
<b>C</b>	8	8000 93036	1	Tubo mandata olio	Hose	Tuyau	Rohr	Tubo	
<b>W</b>	9	8000 A4569	1	Regolazione	Adjuster	Registre	Regler	Regulizador	
<b>C</b>	9	8000 A4566	1	Regolazione	Adjuster	Registre	Regler	Regulizador	
	11	8000 99674	1	Pinza freno (250)	Brake caliper (250)	Etrier frein (250)	Bremssattel (250)	Pinza (250)	
	11	8000 A5992	1	Pinza freno (450-510)	Brake caliper (450-510)	Etrier frein (450-510)	Bremssattel (450-510)	Pinza (450-510)	
	12	8000 62733	1	Vite	Screw	Vis	Schraube	Tornillo	
	13	8A00 62733	1	Vite (250)	Screw (250)	Vis (250)	Schraube (250)	Tornillo (250)	
	13	8000 62733	1	Vite (450-510)	Screw (450-510)	Vis (450-510)	Schraube (450-510)	Tornillo (450-510)	
<b>R</b>	14	8000 71445	1	Olio freni	Brake oil	Huile frein	Bremsol	Aceite freni	
<b>XW</b>	15	8000 A0929	1	Interruttore stop	Stop switch	Interrupteur stop	Stopschalter	Interruptor stop	
	16	8000 49654	1	Oblò	Inspection plug	Capuchon de inspection	Stopfen	Portilla	
	17	8000 96934	1	Coppia pastiglie (250)	Pads pair (250)	Paire plaquettes (250)	Bremsbelagpaar (250)	Pareja pastillas (250)	
	17	8000 A7143	1	Coppia pastiglie (450-510)	Pads pair (450-510)	Paire plaquettes (450-510)	Bremsbelagpaar (450-510)	Pareja pastillas (450-510)	
	18	8000 A0932	1	Perni	Pin	Pivot	Bolzen	Perno	
	19	8000 A0931	1	Spurgo	Spurgo	Drain	Entleerung	Purga	
	20	8000 53259	1	Parapolvere (250)	Boots (250)	Para-poudre (250)	Schutzhaube (250)	Para-polvo (250)	
	20	8000 A2042	1	Parapolvere (450-510)	Boots (450-510)	Para-poudre (450-510)	Schutzhaube (450-510)	Para-polvo (450-510)	
	21	8000 79065	1	Molla-lamierino (250)	Spring-steel clip (250)	Ressort (250)	Feder (250)	Rresorte (250)	
	21	8000 A7144	1	Molla-lamierino (450-510)	Spring-steel clip (450-510)	Ressort (450-510)	Feder (450-510)	Rresorte (450-510)	
	22	8000 79066	1	Cuffie	Boots	Poussiers	haube	Gorro	
	23	8000 57155	2	Vite	Screw	Vis	Schraube	Tornillo	
	24	8000 21480	4	Rosetta	Washer	Rondell'e	Scheibe	Arandela	
	25	8000 A0930	1	Pistone (250)	Piston (250)	Piston (250)	Kolben (250)	Pistón (250)	

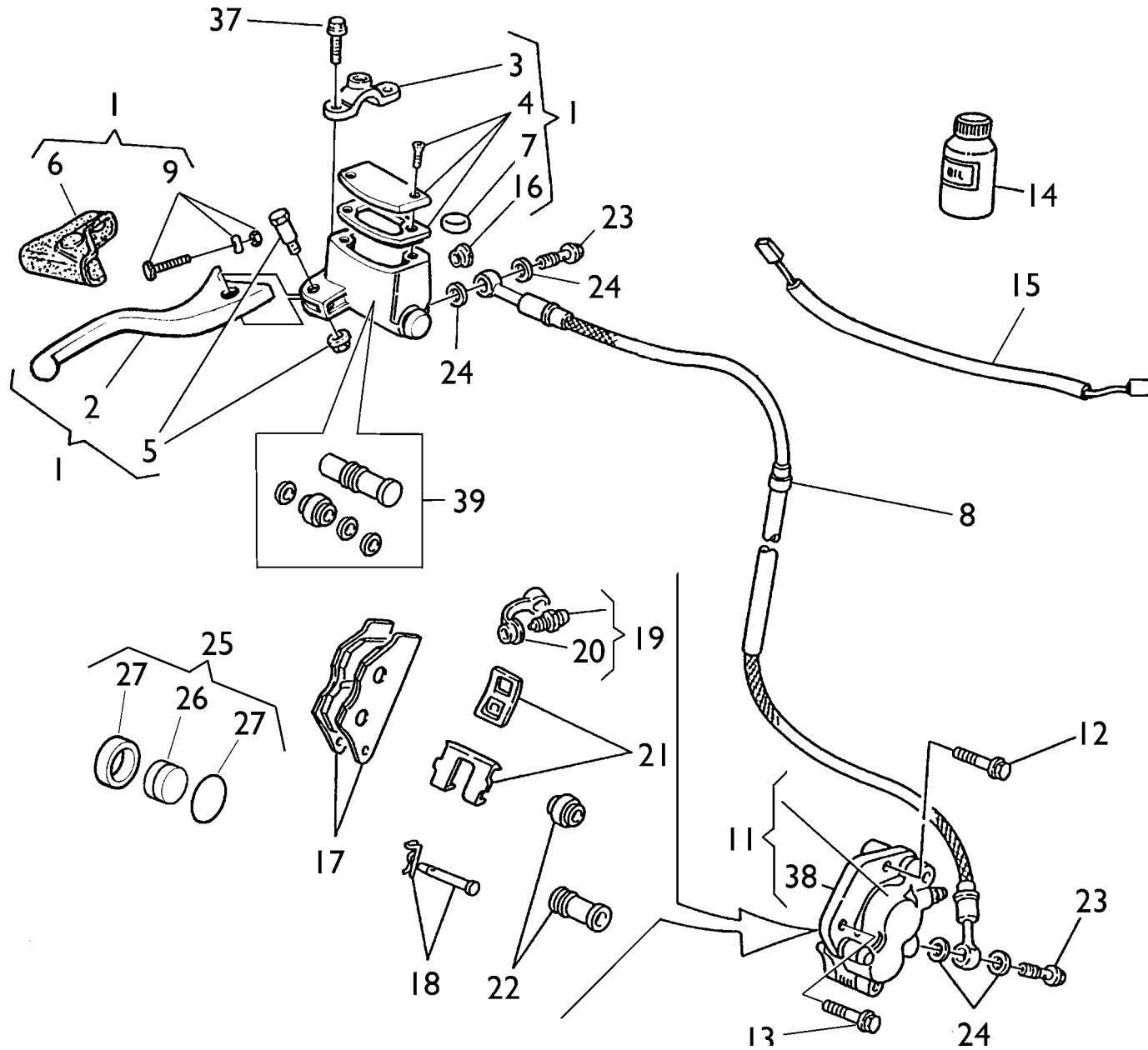



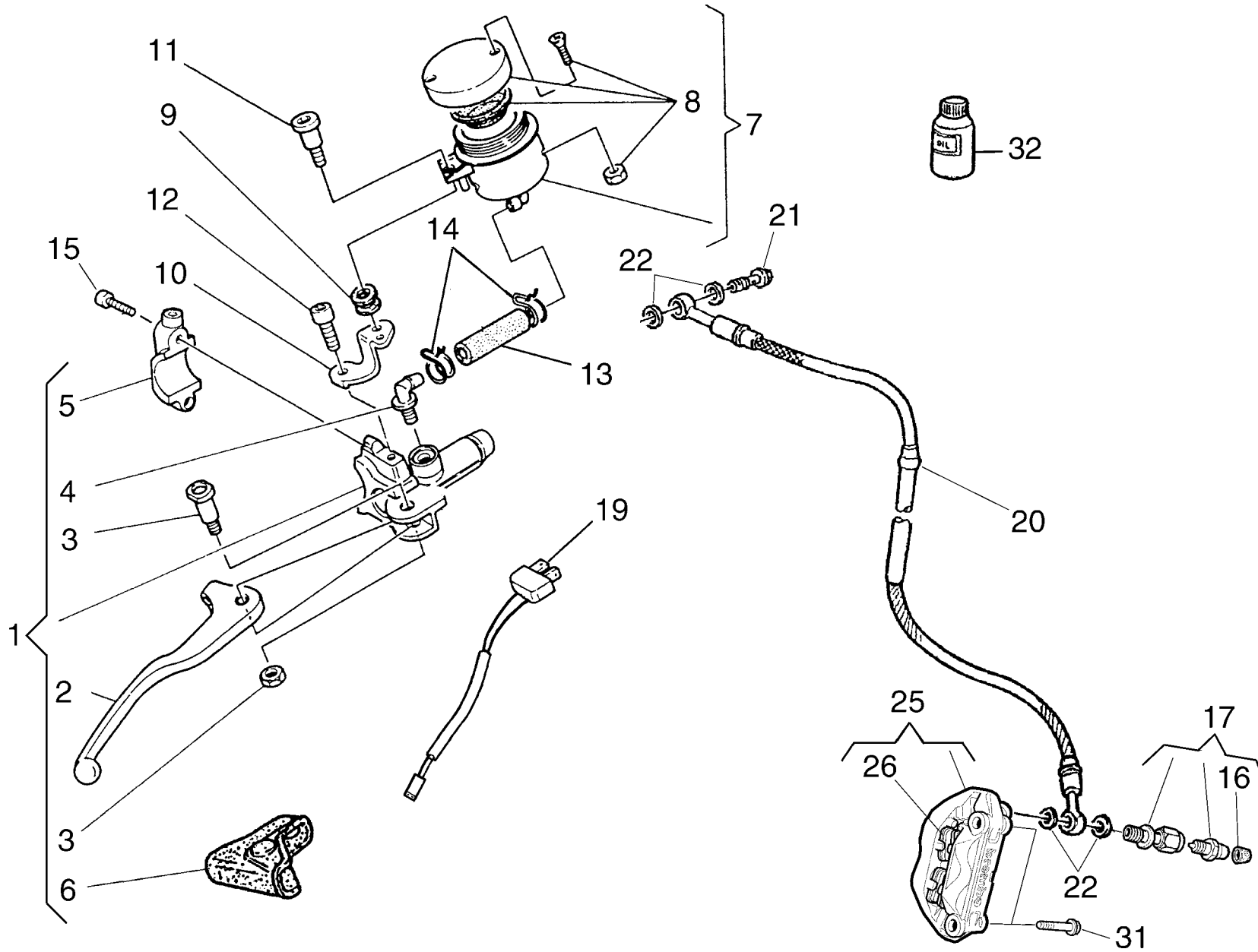



Note Notes Notas	Pos. No. N. Index Pos.	N. Cod. Code No. Nr. Code Code Nr N. Cod.	Q.tà Q.ty Q.te M.ge C.ad	DENOMINAZIONE	NAME	DESIGNATION	BESHREIBUNG	DENOMINACION	Validità Validity Validité Gültig Validez
	1	8000 A6076	1	Pompa comando freno ant.	Brake pump	Pompe frein	Bremspumpe	Bomba freno	
	2	80A0-52662	4	Leva	Lever	Levier	Hebel	Palanca	
	3	8000-46664	4	Gruppo revisione perno leva	Pin lever	Goujon levier	Bolzen-Hebel	Perno-palanca	
	4	8000-42345	4	Gruppo revisione raccordo	Connection-set	Kit revision-raccord	Anschluss-repar.-Stz	Grupo-revis.-empalme	
	5	8000-A0879	4	Cavalotto	U-bolt	Cavalier	Bügelbolzen	Gaballete	
	6	8000-A0844	4	Cappuccio	Cap	Capuchon	Kappe	Capuchon	
	7	8000 66181	1	Serbatoio olio	Oil tank	Reservoir huile	Öltank	Depósito aceite	
	8	8000 68490	1	Gruppo revisione tappo	Plug set	Kit revision capuchon	Stopfensatz	Grupo revis. tapón	
	9	8000 33288	1	Antivibrante	Rubber pad	Pièce caoutchouc	Gummstück	Junta de goma	
	10	8A00 A6229	1	Piastrina	Plate	Plaquette	Plättchen	Placa	
	11	8000 A1189	1	Vite	Screw	Vis	Schraube	Tornillo	
	12	8000 62725	1	Vite	Screw	Vis	Schraube	Tornillo	
	13	8G00 66179	1	Tubazione	Pipe	Tuyau	Rohr	Tubo	
	14	8000 18921	2	Anello SEEGER	SEEGER ring	Anneau SEEGER	Ring SEEGER	Anillo SEEGER	
	15	8000 62729	2	Vite (M6x25mm)	Screw (M6x25mm)	Vis (M6x25mm)	Schraube (M6x25mm)	Tornillo (M6x25mm)	
	16	8000 A3975	1	Bocchettone	Pipe union	Goulotte	Stutzen	Boca	
	17	8000 53259	1	Parapolvere	Dust cover	Para poussière	Staubdeckel	Tapa retención polvo	
	19	8000 A0672	1	Interruttore stop	Stop switch	Interrupteur stop	Stopschalter	Interruptor stop	
	20	8A00 A1706	1	Tubo mandata olio	Pipe	Tuyau	Rohr	Tubo	
	21	8000 57155	1	Bocchettone	Pipe union	Goulotte	Stutzen	Boca	
	22	8000 21480	4	Rosetta di tenuta	Washer	Rondelle	Scheibe	Arandela	
	25	8000 A6078	1	Pinza freno	Brake caliper	Etrier frein	Bremssattel	Pinza	
	26	8000 A2040	1	Coppia pastiglie	Pads pair	Paire plaquettes	Bremsbelagpaar	Pareja pastillas	
	29	8000 A2043	1	Kit perno copiglia	Pin kit	Kit pivot	Bolzengruppe	Grupo perno	
	31	8S00 82751	2	Vite	Screw	Vis	Schraube	Tornillo	
<b>R</b>	32	8000 71445	1	Olio freni	Brake oil	Huile frein	Bremsöl	Aceite freni	

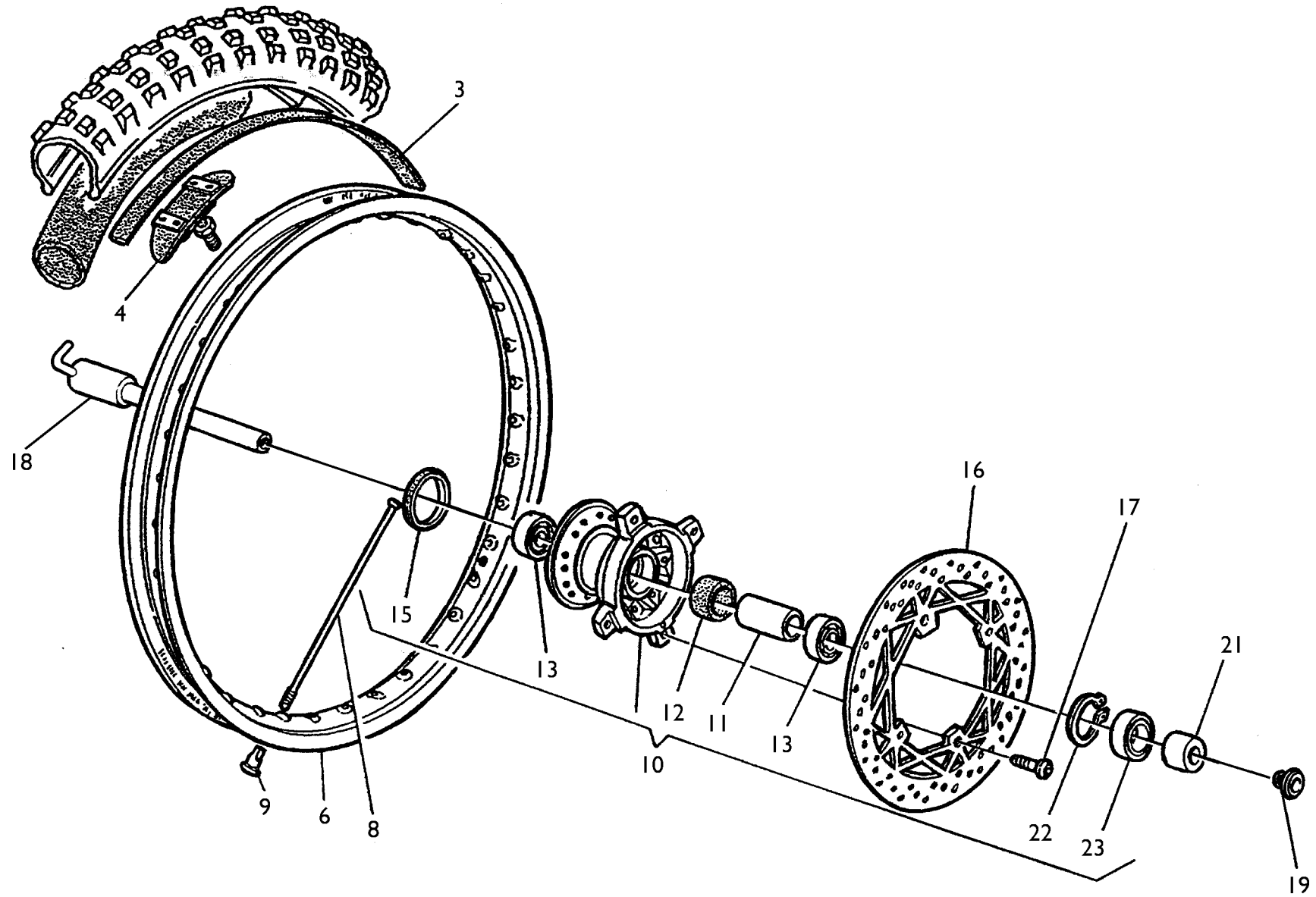

Note Notes Notas	Pos. No. N. Index Pos.	N. Cod. Code No. Nr. Code Code Nr N. Cod.	Q.tà Q.ty Q.te M.ge C.ad	DENOMINAZIONE	NAME	DESIGNATION	BESHREIBUNG	DENOMINACION	Validità Validity Validité Gültig Validez
	3	8000 13346	1	Fascia copriraggi	Rim strip	Bande	Band	Banda	
	4	8000 49036	1	Staffa fermacopertone	Bracket	Etrier	Buegel	Brida	
	6	8A00 53504	1	Cerchio (1,6x21")	Rim (1,6x21")	Jante (1,6x21")	Felge (1,6x21")	Llanta (1,6x21")	
	8	8000 A0080	36	Raggio	Spoke	Bras	Speiche	Radio	
	9	8000 A0081	36	Nipplo	Nipple	Nipple	Nippel	Nipple	
	10	8000 96838	1	Mozzo completo	Hub assy	Moyeau compl.	Radnabe, Kpl.	Cubo compl.	
	11	8000 96928	1	Distanziale	Spacer	Entretoise	Distanzstück	Separador	
	12	8000 92797	1	Portadistanziale	Spacer holder	Porte-entretoise	Abstandstückhalter	Porta-distancial	
	13	8000 84938	2	Cuscinetto a sfere (ø25xø42x9 mm)	Ball bearing (ø25xø42x9 mm)	Roulement à billes (ø25xø42x9 mm)	Kugellager (ø25xø42x9 mm)	Cojinete de bolas (ø25xø42x9 mm)	
	15	8A00 92986	1	Anello di tenuta (ø28xø50x5 mm)	Seal ring (ø28xø50x5 mm)	Bague d'étanchéité (ø28xø50x5 mm)	Dichtungsring (ø28xø50x5 mm)	Anillo de retención (ø28xø50x5 mm)	
	16	8000 99632	1	Disco freno (Ø260 mm) (TE 250, TC)	Brake disc (Ø260 mm) (TE 250, TC)	Disque frein (Ø260 mm) (TE 250, TC)	Bremsscheibe (Ø260 mm) (TE 250, TC)	Disco freno (Ø260 mm) (TE 250, TC)	
	16	8000 A6294	1	Disco freno (Ø260 mm) (TE 450-510)	Brake disc (Ø260 mm) (TE 450-510)	Disque frein (Ø260 mm) (TE 450-510)	Bremsscheibe (Ø260 mm) (TE 450-510)	Disco freno (Ø260 mm) (TE 450-510)	
	17	8A00 55241	4	Vite	Screw	Vis	Schraube	Tornillo	
	18	8000 A2785	1	Perno ruota (TE 250)	Pin (TE 250)	Pivot (TE 250)	Bolzen (TE 250)	Perno ruota (TE 250)	
	18	8B00 A2785	1	Perno ruota (TE 450-510)	Pin (TE 450-510)	Pivot (TE 450-510)	Bolzen (TE 450-510)	Perno ruota (TE 450-510)	
	18	8000 96932	1	Perno ruota (TC 250)	Pin (TC 250)	Pivot (TC 250)	Bolzen (TC 250)	Perno ruota (TC 250)	
	18	8B00 96932	1	Perno ruota (TC 450-510)	Pin (TC 450-510)	Pivot (TC 450-510)	Bolzen (TC 450-510)	Perno ruota (TC 450-510)	
	19	8000 96933	1	Vite	Screw	Vis	Schraube	Tornillo	
	21	8000 96930	1	Distanziale (250)	Spacer (250)	Entretoise (250)	Distanzstück (250)	Separador (250)	
	21	8A00 96930	1	Distanziale (450-510)	Spacer (450-510)	Entretoise (450-510)	Distanzstück (450-510)	Separador (450-510)	
	22	66N0 21270	1	Anello SEEGER	SEEGER ring	Anneau SEEGER	Ring SEEGER	Anillo SEEGER	
	23	8000 22966	1	Anello di tenuta (ø32xø42x7 mm)	Seal ring (ø32xø42x7 mm)	Bague d'étanchéité (ø32xø42x7 mm)	Dichtungsring (ø32xø42x7 mm)	Anillo de retención (ø32xø42x7 mm)	

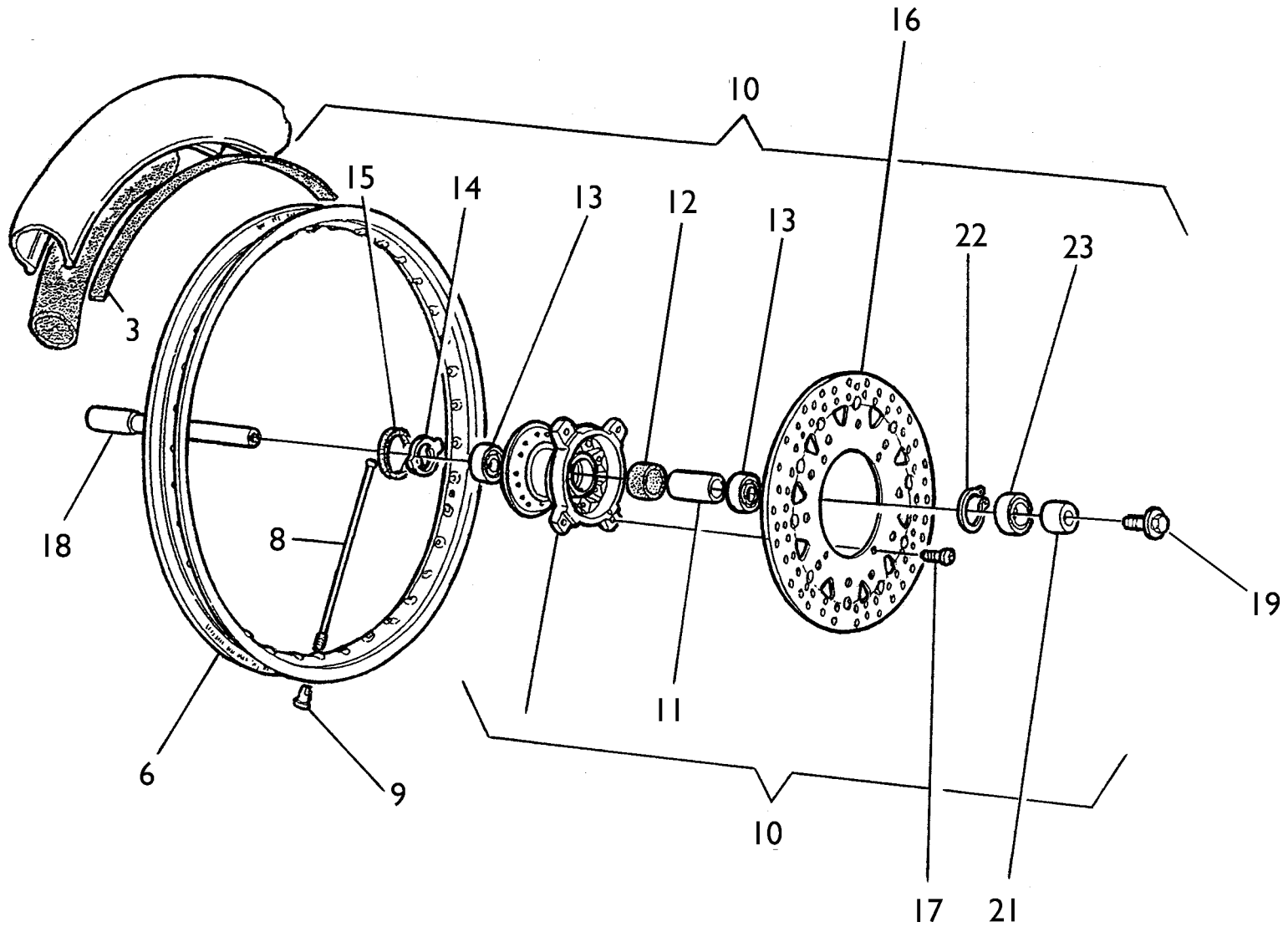

Note Notes Markes Notas	Pos. No. N. Index Pos.	N. Cod. Code No. Nr. Code Code Nr N. Cod.	Q.tà Q.ty Q.te M.ge C.ad	DENOMINAZIONE	NAME	DESIGNATION	BESHREIBUNG	DENOMINACION	Validità Validity Validité Gültig Validez
	3	8B00 82879	1	Fascia copriraggi	Rim strip	Bande	Band	Banda	
	6	8000 91525	1	Cerchio (3,5x17")	Rim (3,5x17")	Jante (3,5x17")	Felge (3,5x17")	Llanta (3,5x17")	
	8	8000 94754	18	Raggio	Spoke	Bras	Speiche	Radio	
	8	8A00 94754	18	Raggio (lato disco)	Spoke (disc side)	Bras (côté disque)	Speiche (Scheibe Seite)	Radio (lado disco)	
	9	69N4 29004	36	Nipplo	Nipple	Nipple	Nippel	Nipple	
	10	8B00 96838	1	Mozzo completo	Hub assy	Moyeau compl.	Radnabe, Kpl.	Cubo compl.	
	11	8000 96928	1	Distanziale	Spacer	Entretoise	Distanzstück	Separador	
	12	8000 92797	1	Portadistanziale	Spacer holder	Porte-entretoise	Abstandstückhalter	Porta-distancial	
	13	8000 84938	2	Cuscinetto a sfere	Ball bearing	Roulement à billes	Kugellager	Cojinete de bolas	
				(ø25xø42x9mm)	(ø25xø42x9mm)	(ø25xø42x9mm)	(ø25xø42x9mm)	(ø25xø42x9mm)	
	15	8A00 92986	1	Anello di tenuta	Seal ring	Bague d'étanchéité	Dichtungsring	Anillo de retención	
				(ø42xø50x9mm)	(ø42xø50x9mm)	(ø42xø50x9mm)	(ø42xø50x9mm)	(ø42xø50x9mm)	
	16	8000 A1709	1	Disco freno (ø320mm)	Brake disc (ø320mm)	Disque frein (ø320mm)	Bremsscheibe (ø320mm)	Disco freno (ø320mm)	
	17	8A00 92876	4	Vite	Screw	Vis	Schraube	Tornillo	
	18	8B00 96932	1	Perno ruota	Pin	Pivot	Bolzen	Perno rueda	
	19	8000 96933	1	Vite	Screw	Vis	Schraube	Tornillo	
	21	8A00 96930	1	Parapolvere	Dust guard	Pare poussière	Staubdeckel	Tapa retención polvo	
	22	66N0 21270	1	Anello SEEGER	SEEGER ring	Anneau SEEGER	Ring SEEGER	Anillo SEEGER	
	23	8000 22966	1	Distanziale	Spacer	Entretoise	Distanzstück	Separador	
				D42-d32-Sp7	D42-d32-Th7	D42-d32-ép7	D42-d32-S7	D42-d32-esp7	

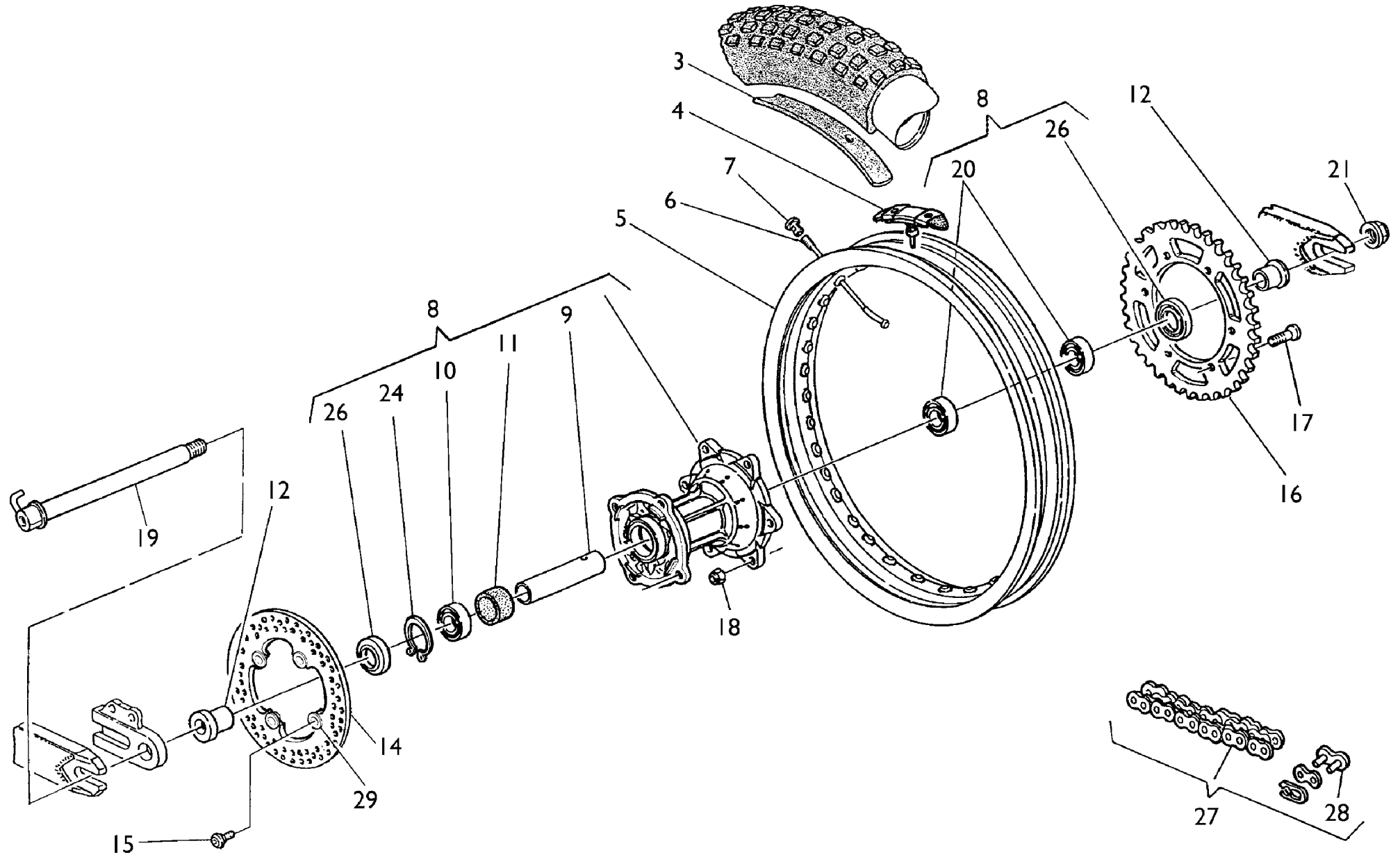



Note Notes Notas	Pos. No. Index Pos.	N. Cod. Code No. Nr. Code Code Nr N. Cod.	Q.tà Q.ty Q.te M.ge C.ad	DENOMINAZIONE	NAME	DESIGNATION	BESHREIBUNG	DENOMINACION	Validità Validity Validité Gültig Validez
<b>W</b>	3	8000 01688	1	Fascia copriraggi	Rim strip	Bande	Band	Banda	
<b>C</b>	3	8000 10777	1	Fascia copriraggi	Rim strip	Bande	Band	Banda	
<b>M</b>	3	8B00 82879	1	Fascia copriraggi	Rim strip	Bande	Band	Banda	
	4	8000 54073	1	Staffa fermacopertone	Bracket	Etrier	Buegel	Brida	
				(TE, TC 450-510)	(TE, TC 450-510)	(TE, TC 450-510)	(TE, TC 450-510)	(TE, TC 450-510)	
	4	8000 49035	1	Staffa fermacopertone	Bracket	Etrier	Buegel	Brida	
				(TC 250)	(TC 250)	(TC 250)	(TC 250)	(TC 250)	
<b>W</b>	5	8A00 55860	1	Cerchio (2,15 x 18")	Rim (2,15 x 18")	Jante (2,15 x 18")	Felge (2,15 x 18")	Llanta (2,15 x 18")	
	5	8A00 58930	1	Cerchio (2,15 x 18")	Rim (2,15 x 18")	Jante (2,15 x 18")	Felge (2,15 x 18")	Llanta (2,15 x 18")	
				(TC 250)	(TC 250)	(TC 250)	(TC 250)	(TC 250)	
	5	8A00 58929	1	Cerchio (2,15 x 18")	Rim (2,15 x 18")	Jante (2,15 x 18")	Felge (2,15 x 18")	Llanta (2,15 x 18")	
				(TC 450-510)	(TC 450-510)	(TC 450-510)	(TC 450-510)	(TC 450-510)	
<b>M</b>	5	8000 92612	1	Cerchio (4,25 x 17")	Rim (4,25 x 17")	Jante (4,25 x 17")	Felge (4,25 x 17")	Llanta (4,25 x 17")	
<b>W</b>	6	8000 A0085	36	Raggio	Spoke	Bras	Speiche	Radio	
<b>C</b>	6	8A00 A0085	36	Raggio	Spoke	Bras	Speiche	Radio	
<b>M</b>	6	8000 94757	36	Raggio	Spoke	Bras	Speiche	Radio	
<b>WC</b>	7	8000 A0086	36	Nipplo	Nipple	Nipple	Nippel	Nipple	
<b>M</b>	7	69N4 29005	36	Nipplo	Nipple	Nipple	Nippel	Nipple	
<b>WC</b>	8	8A00 96937	1	Mozzo completo	Hub assy	Moyeau compl.	Radnabe, Kpl.	Cubo compl.	
<b>M</b>	8	8A00 97593	1	Mozzo completo	Hub assy	Moyeau compl.	Radnabe, Kpl.	Cubo compl.	
<b>WC</b>	9	8000 92414	1	Distanziale	Spacer	Entretoise	Distanzstück	Separador	
<b>M</b>	9	8A00 86938	1	Distanziale	Spacer	Entretoise	Distanzstück	Separador	
	10	8B00 26846	1	Cuscinetto(ø25xø47x16 mm)	Bearing (ø25xø47x16 mm)	Roulement (ø25xø47x16 mm)	Kugellager (ø25xø47x16 mm)	Cojinete (ø25xø47x16 mm)	
<b>MA</b>	10	8D00 26846	1	Cuscinetto(ø25xø47x16 mm)	Bearing (ø25xø47x16 mm)	Roulement (ø25xø47x16 mm)	Kugellager (ø25xø47x16 mm)	Cojinete (ø25xø47x16 mm)	
	11	8000 92797	1	Porta distanziale	Spacer	Entretoise	Distanzstück	Separador	
	12	8000 96938	2	Distanziale	Spacer	Entretoise	Distanzstück	Separador	
<b>CM</b>	14	8000 A4288	1	Disco freno (ø240 mm)	Brake disc (ø240 mm)	Disque frein (ø240 mm)	Bremsscheibe (ø240 mm)	Disco freno (ø240 mm)	
<b>W</b>	14	8A00 A4288	1	Disco freno (ø240 mm)	Brake disc (ø240 mm)	Disque frein (ø240 mm)	Bremsscheibe (ø240 mm)	Disco freno (ø240 mm)	
	15	8000 62726	4	Vite	Screw	Vis	Schraube	Tornillo	
<b>C</b>	16	8000 96837	1	Corona (Z= 46) TC 510	Ring gear (Z = 46)	Couronne (Z = 46)	Kranz (Z = 46)	Corona (Z = 46)	
<b>RWC</b>	16	8A00 96837	1	Corona (Z= 47)	Ring gear (Z = 47)	Couronne (Z = 47)	Kranz (Z = 47)	Corona (Z = 47)	
<b>RWC</b>	16	8B00 96837	1	Corona (Z= 48)	Ring gear (Z = 48)	Couronne (Z = 48)	Kranz (Z = 48)	Corona (Z = 48)	
<b>RWC</b>	16	8C00 96837	1	Corona (Z= 49)	Ring gear (Z = 49)	Couronne (Z = 49)	Kranz (Z = 49)	Corona (Z = 49)	

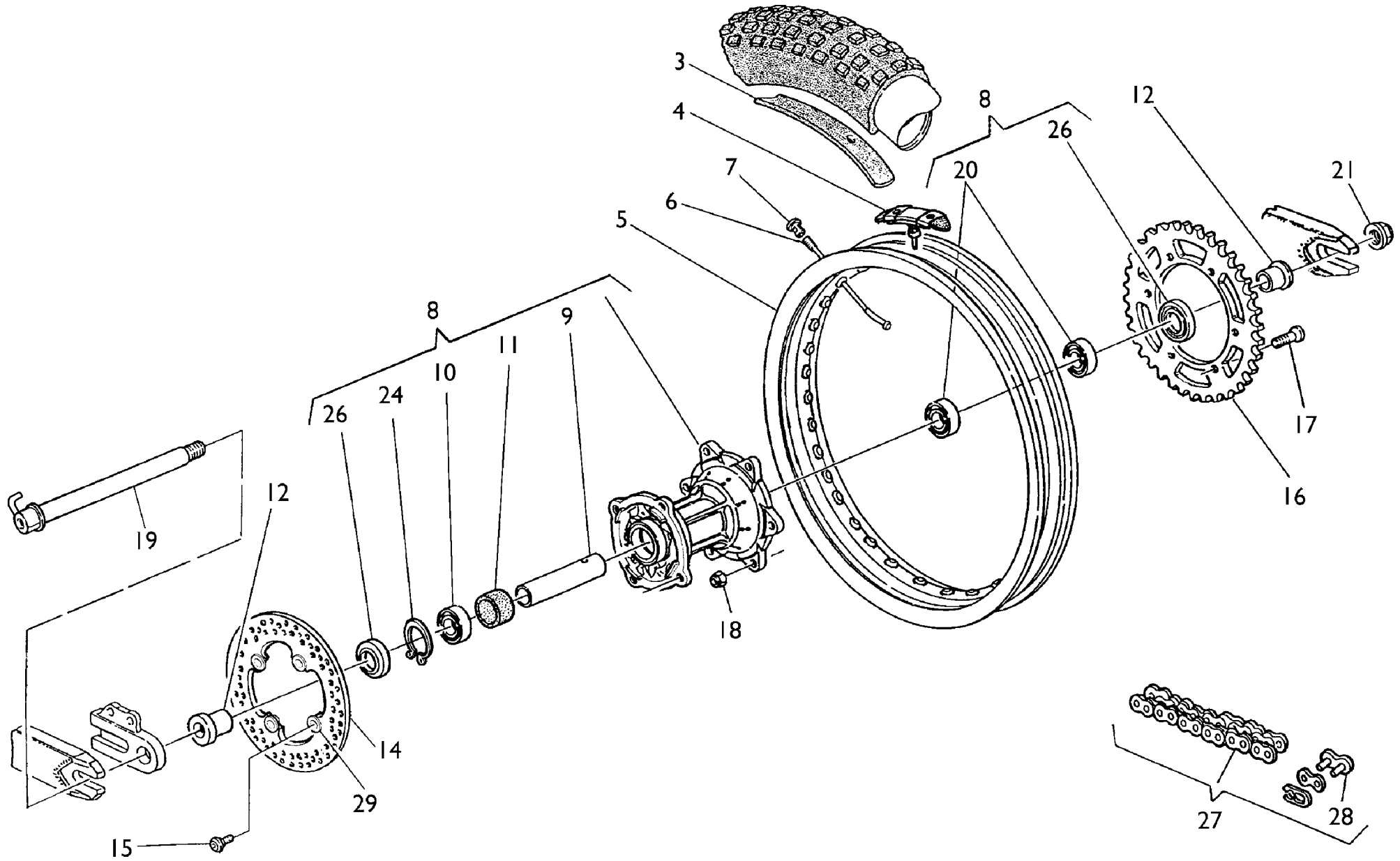

Note Notes Notas	Pos. No. Index Pos.	N. Cod. Code No. Nr. Code Code Nr N. Cod.	Q.tà Q.ty Q.te M.ge C.ad	DENOMINAZIONE	NAME	DESIGNATION	BESHREIBUNG	DENOMINACION	Validità Validity Validité Gültig Validez
<b>WC</b>	16	8D00 96837	1	Corona (Z= 50) TC250-450, TE	Ring gear (Z = 50)	Couronne (Z = 50)	Kranz (Z = 50)	Corona (Z = 50)	
<b>M</b>	16	8000 A4859	1	Corona (Z= 42) SMR	Ring gear (Z = 42)	Couronne (Z = 42)	Kranz (Z = 42)	Corona (Z = 42)	
<b>RM</b>	16	8A00 A4859	1	Corona (Z= 43)	Ring gear (Z = 43)	Couronne (Z = 43)	Kranz (Z = 43)	Corona (Z = 43)	
<b>RM</b>	16	8B00 A4859	1	Corona (Z= 44)	Ring gear (Z = 44)	Couronne (Z = 44)	Kranz (Z = 44)	Corona (Z = 44)	
<b>RM</b>	16	8G00 96837	1	Corona (Z= 45)	Ring gear (Z = 45)	Couronne (Z = 45)	Kranz (Z = 45)	Corona (Z = 45)	
	17	8000 40796	6	Vite	Screw	Vis	Schraube	Tornillo	
	18	8000 43928	6	Dado	Nut	Ecrou	Mutter	Tuierca	
<b>W</b>	19	8000 A2788	1	Perno	Pin	Pivot	Bolzen	Perno	
<b>CM</b>	19	8000 96940	1	Perno	Pin	Pivot	Bolzen	Perno	
	20	8A00 26846	2	Cuscinetto (ø25xø47x12 mm)	Bearing (ø25xø47x12 mm)	Roulement (ø25xø47x12 mm)	Kugellager (ø25xø47x12 mm)	Cojinete (ø25xø47x12 mm)	
<b>MA</b>	20	8C00 26846	2	Cuscinetto (ø25xø47x12 mm)	Bearing (ø25xø47x12 mm)	Roulement (ø25xø47x12 mm)	Kugellager (ø25xø47x12 mm)	Cojinete (ø25xø47x12 mm)	
	21	8000 93072	1	Dado	Nut	Ecrou	Mutter	Tuerca	
	24	66N0 21272	1	Anello SEEGER	SEEGER ring	Anneau SEEGER	Ring SEEGER	Anillo SEEGER	
	26	8000 89572	2	Anello di tenuta Ø32xø47x7	Seal ring Ø32xø47x7	Bague d'étanch. Ø32xø47x7	Dichtungsring Ø32xø47x7	Anillo de retenc. Ø32xø47x7	
<b>W</b>	27	8B00 65442	1	Catena 5/8"x6,5 (114 maglie)	Chain 5/8"x6,5 (114 link)	Chaîne 5/8"x6,5 (114 maillon)	Kette 5/8"x6,5 (114 Schake)	Cadena 5/8"x6,5 (114 malla)	
<b>WA</b>	27	8B00 79783	1	Catena 5/8"x6,5 (114 maglie)	Chain 5/8"x1/4"(114 link)	Chaîne 5/8"x6,5 (114 maillon)	Kette 5/8"x6,5 (114 Schake)	Cadena 5/8"x6,5 (114 malla)	
	27	8000 56768	1	Catena 5/8"x6,5 (114 maglie) (TC 250-510)	Chain 5/8"x1/4"(114 link) (TC 250-510)	Chaîne 5/8"x6,5 (114 maillon) (TC 250-510)	Kette 5/8"x6,5 (114 Schake) (TC 250-510)	Cadena 5/8"x6,5 (114 malla) (TC 250-510)	
<b>A</b>	27	8B00 79785	1	Catena 5/8"x6,5 (114 maglie) (TC 250-510)	Chain 5/8"x1/4"(114 link) (TC 250-510)	Chaîne 5/8"x6,5 (114 maillon) (TC 250-510)	Kette 5/8"x6,5 (114 Schake) (TC 250-510)	Cadena 5/8"x6,5 (114 malla) (TC 250-510)	
	27	8C00 56768	1	Catena 5/8"x6,5 (116 maglie) (TC 450)	Chain 5/8"x1/4"(116 link) (TC 450)	Chaîne 5/8"x6,5 (116 maillon) (TC 450)	Kette 5/8"x6,5 (116 Schake) (TC 450)	Cadena 5/8"x6,5 (116 malla) (TC 450)	
<b>A</b>	27	8F00 79785	1	Catena 5/8"x6,5 (116 maglie) (TC 450)	Chain 5/8"x1/4"(116 link) (TC 450)	Chaîne 5/8"x6,5 (116 maillon) (TC 450)	Kette 5/8"x6,5 (116 Schake) (TC 450)	Cadena 5/8"x6,5 (116 malla) (TC 450)	
<b>M</b>	27	8G00 79783	1	Catena 5/8"x6,5 (110 maglie)	Chain 5/8"x6,5 (110 link)	Chaîne 5/8"x6,5 (110 maillon)	Kette 5/8"x6,5 (110 Schake)	Cadena 5/8"x6,5 (110 malla)	
<b>WA</b>	28	8000 65464	1	Giunto	Coupling	Joint	Kupplung	Junta	
<b>WM</b>	28	8000 79789	1	Giunto	Coupling	Joint	Kupplung	Junta	
<b>C</b>	28	8000 56767	1	Giunto	Coupling	Joint	Kupplung	Junta	
<b>CA</b>	28	8000 79790	1	Giunto	Coupling	Joint	Kupplung	Junta	
<b>W</b>	29	8A00 A0693	4	Bussola	Bushing	Douille	Buchse	Manguito	
<b>CM</b>	29	8000 A0693	4	Bussola	Bushing	Douille	Buchse	Manguito	

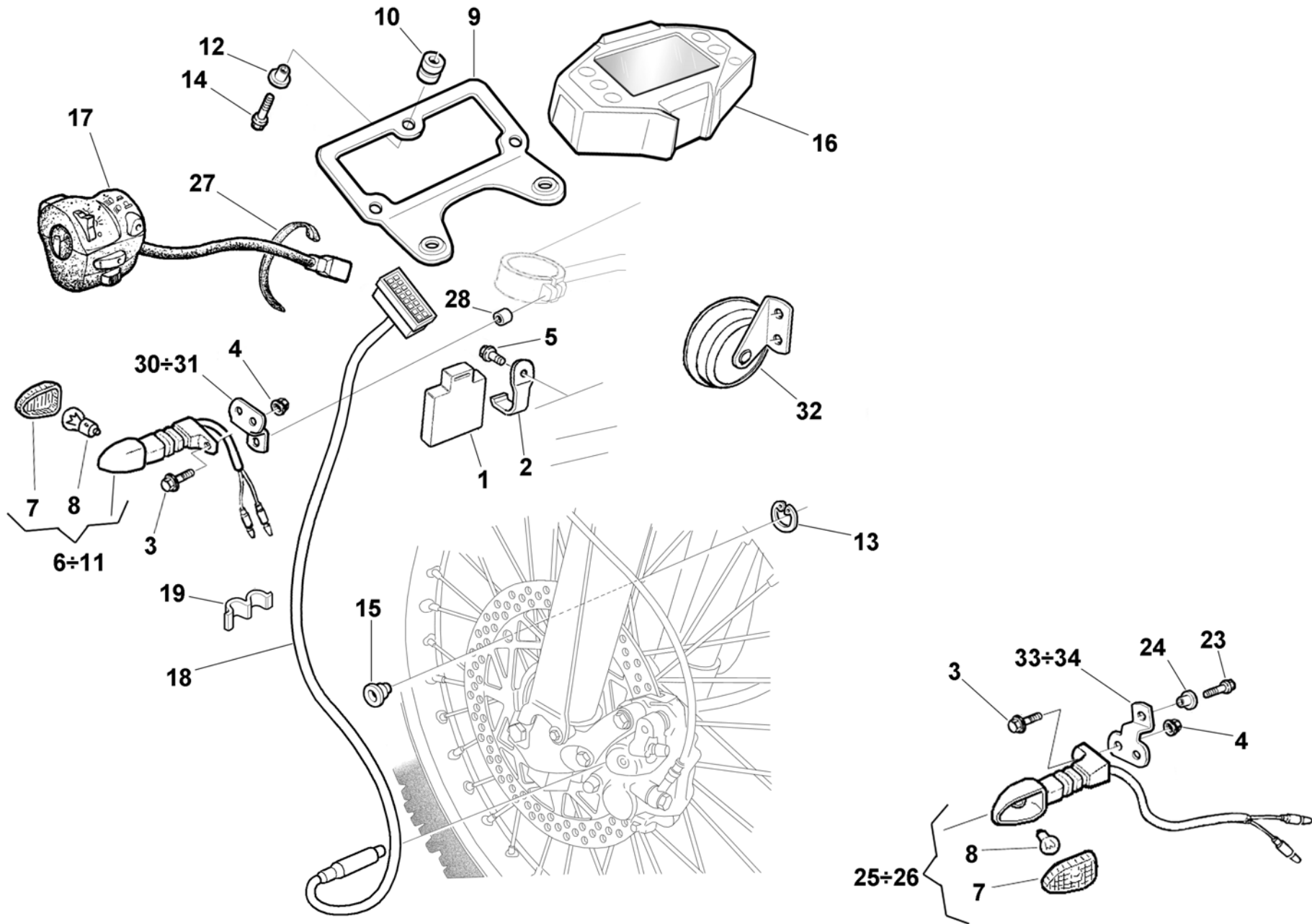

Note Notes Notas	Pos. No. Index Pos.	N. Cod. Code No. Nr. Code Code Nr N. Cod.	Q.tà Q.ty Q.te M.ge C.ad	DENOMINAZIONE	NAME	DESIGNATION	BESHREIBUNG	DENOMINACION	Validità Validity Validité Gültig Validez
<b>DX</b>	1	8000 A0645	1	Intermittenza	Flash device	Intermittence	Blinkgeber	Intermitencia	
<b>DX</b>	2	8000 A0678	1	Piastra per intermittenza	Plate (Flash device)	Plaque (Intermittence)	Platte (Blinkgeber)	Placa (Intermitencia)	
<b>DX</b>	3	8000 62727	4	Vite (M6x16 mm)	Screw (M6x16 mm)	Vis (M6x16 mm)	Schraube (M6x16 mm)	Tornillo (M6x16 mm)	
<b>DX</b>	4	8000 44240	4	Dado	Nut	Ecrou	Mutter	Tuerca	
<b>DX</b>	5	8000 67997	1	Vite	Screw	Vis	Schraube	Tornillo	
<b>DX</b>	6	8000 A0227	1	Indicatore anteriore DX	R.H. Blinker	Clignotant D.	R. Blinker	Intermitente D.	
	6	8000 78337	1	Indicatore anteriore DX (U.S.A.)	R.H. Blinker (U.S.A.)	Clignotant D. (U.S.A.)	R. Blinker (U.S.A.)	Intermitente D. (U.S.A.)	
	7	8000 74507	4	Lente (U.S.A.)	Lens (U.S.A.)	Loupe (U.S.A.)	linse (U.S.A.)	Lente (U.S.A.)	
	8	8000 36726	4	Lampada (12V-10W) (U.S.A.)	Lamp (12V-10W) (U.S.A.)	Lampe (12V-10W) (U.S.A.)	Lampe (12V-10W) (U.S.A.)	Lamparilla (12V-10W)(U.S.A.)	
<b>X</b>	9	80A0 99774	1	Piastra	Plate	Plaque	Platte	Placa	
<b>X</b>	10	8000 41862	2	Passacavo	Fairlead	Passe-câble	Kabelführung	Prensa-cable	
<b>DX</b>	11	8000 A0228	1	Indicatore anteriore SX	L.H. Blinker	Clignotant G.	L. Blinker	Intermitente I.	
	11	8000 78338	1	Indicatore ant. SX (U.S.A.)	L.H. Blinker (U.S.A.)	Clignotant G. (U.S.A.)	L. Blinker (U.S.A.)	Intermitente I. (U.S.A.)	
<b>X</b>	12	62N4 15548	2	Rosetta	Washer	Rondelle	Scheibe	Arandela	
<b>WX</b>	13	66N0 21200	1	Anello elastico	Snap ring	Bague d'arret	Haltering	Anillo elástico	
<b>MX</b>	13	66N0 21197	1	Anello elastico	Snap ring	Bague d'arret	Haltering	Anillo elástico	
<b>X</b>	14	8000 89069	2	Vite	Screw	Vis	Schraube	Tornillo	
<b>WX</b>	15	8000 99775	1	Magnete	Magnet	Aimant	Magnet	Imán	
<b>MX</b>	15	8000 A0843	1	Magnete	Magnet	Aimant	Magnet	Imán	
<b>X</b>	16	8000 99650	1	Contachilometri digitale	Digital speedometer	Compteur-km digital	Digital Tachometer	Cuenta-kilómetros digital	
<b>X</b>	17	8000 99625	1	Commutatore SX compl.	L.H. Switch compl.	Commutateur G. compl.	L. Kombischalter kpl.	Conmutador I. compl.	
	17	8000 99721	1	Commutatore SX compl. ( J )	L.H. Switch compl. ( J )	Commutateur G. compl. ( J )	L. Kombischalter kpl. ( J )	Conmutador I. compl. ( J )	
<b>X</b>	18	8000 99652	1	Sensore magnetico	Sensor	Palpeur	Sensor	Sensor	
<b>X</b>	19	8000 A0664	2	Molletta	Clip	Collier	Schelle	Banda	
	23	8000 62726	2	Vite	Screw	Vis	Schraube	Tornillo	
	24	8000 45495	2	Bussola	Bush	Douille	Buchse	Manguito	
<b>DX</b>	25	8000 A0229	1	Indicatore posteriore DX	R.H. Blinker	Clignotant D	Blinker R	Intermitente D	
	25	8000 78340	1	Indicatore post. DX (U.S.A.)	R.H. Blinker (U.S.A.)	Clignotant D (U.S.A.)	Blinker R (U.S.A.)	Intermitente D (U.S.A.)	
<b>DX</b>	26	8000 A0230	1	Indicatore posteriore SX	L.H. Blinker	Clignotant G	Blinker L	Intermitente I	
	26	8000 78339	1	Indicatore post. SX (U.S.A.)	L.H. Blinker (U.S.A.)	Clignotant G (U.S.A.)	Blinker L (U.S.A.)	Intermitente I (U.S.A.)	
	27	8000 71578	2	Fascetta	Clamp	Collier	Schelle	Banda	
	28	8000 A6638	2	Distanziale (TE 450-510, SMR)	Spacer (TE 450-510, SMR)	Entretoise (TE 450-510, SMR)	Distanzstück (TE 450-510, SMR)	Separador(TE 450-510, SMR)	



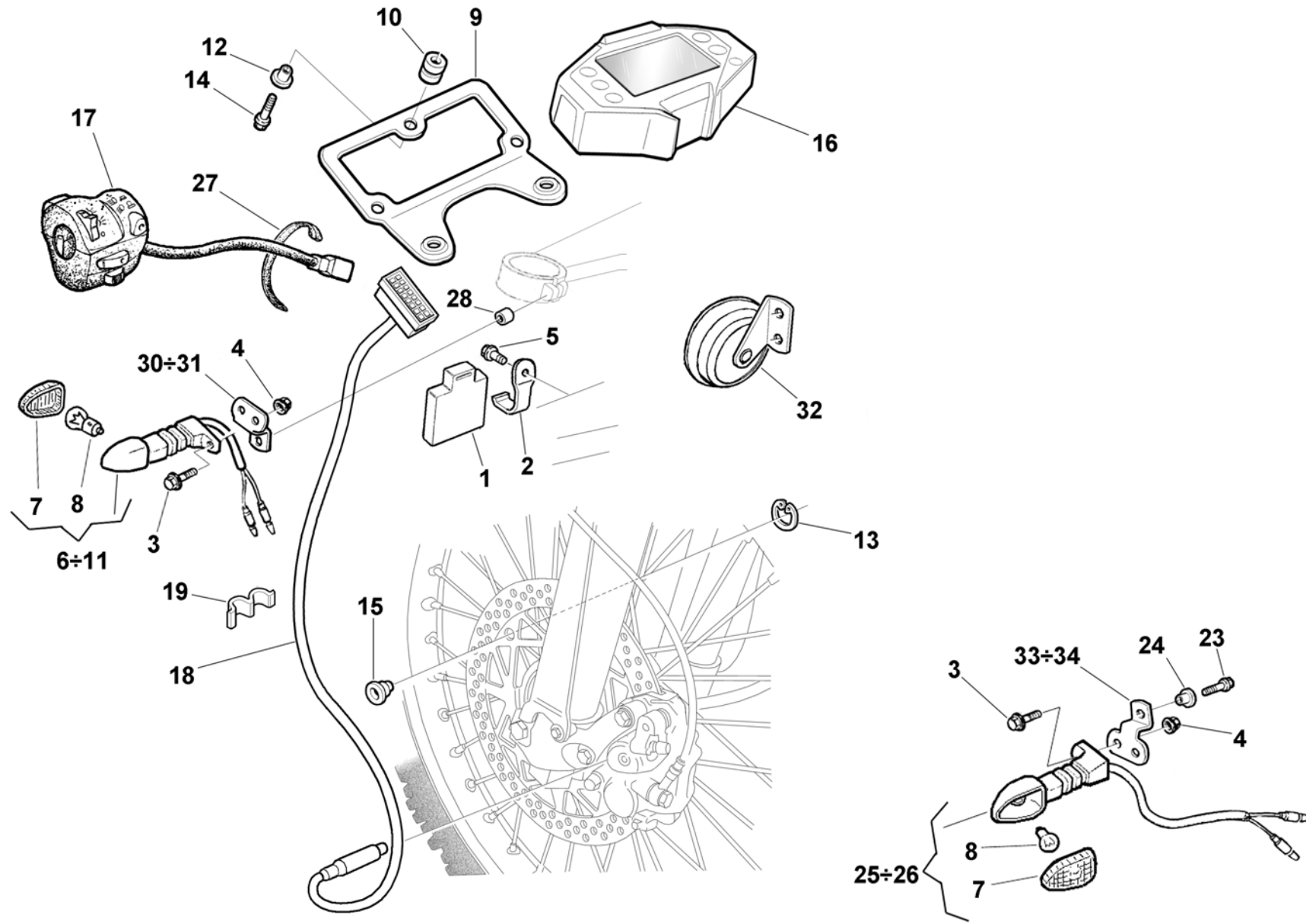





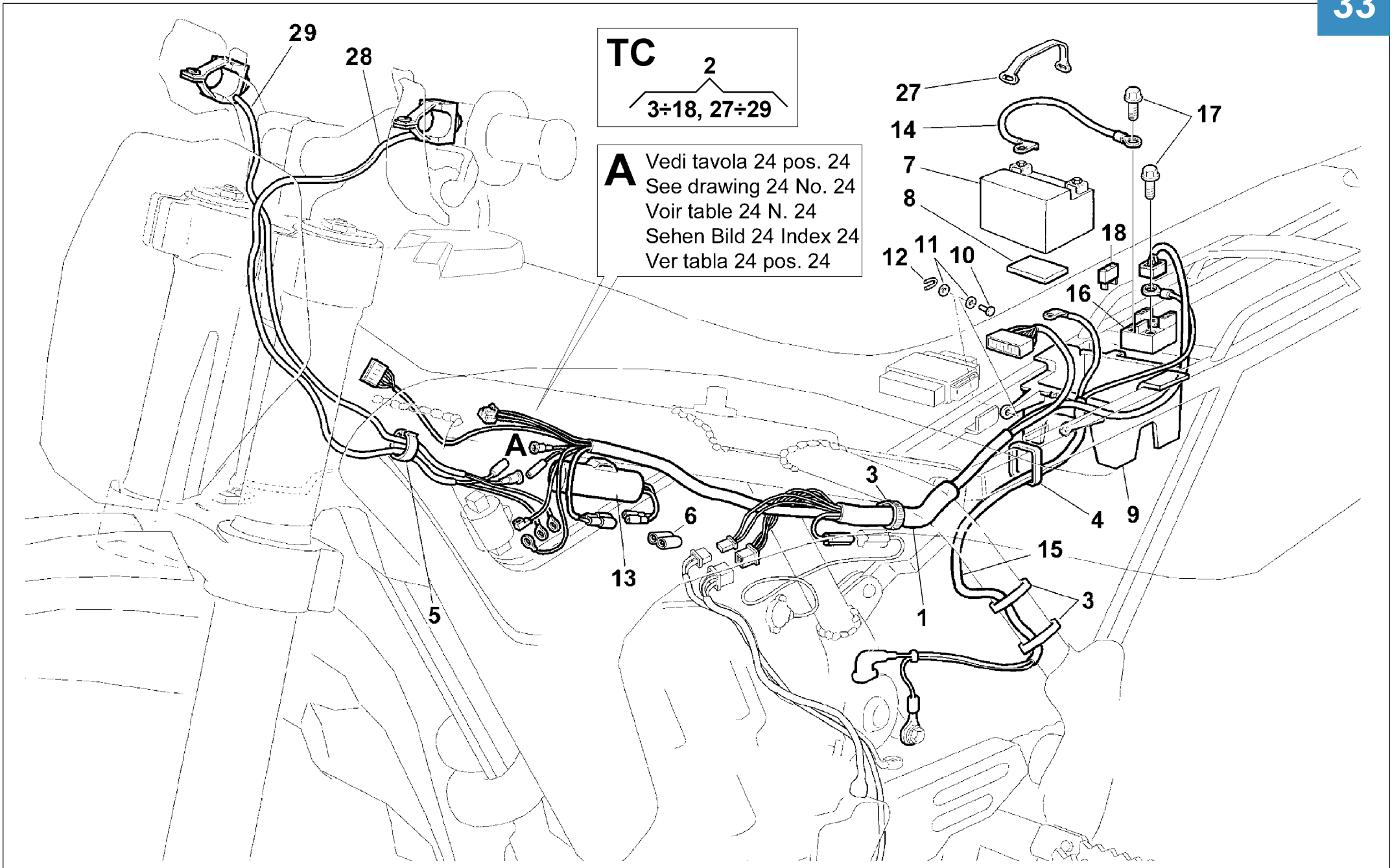

Note Notes Notas	Pos. No. N. Index Pos.	N. Cod. Code No. Nr. Code Code Nr N. Cod.	Q.tà Q.ty Q.te M.ge C.ad	DENOMINAZIONE	NAME	DESIGNATION	BESHREIBUNG	DENOMINACION	Validità Validity Validité Gültig Validez
	1	8000 A4268	1	Gruppo principale cavi (250)	Cable assy (250)	Cables compl. (250)	Kabel Kpl. (250)	Grupo prin. cables (250)	
	1	8000 A4271	1	Gruppo principale cavi (450-510)	Cable assy (450-510)	Cables compl. (450-510)	Kabel Kpl. (450-510)	Grupo prin. cables (450-510)	
<b>k</b>	2		1	Kit avviamento elettrico (250)	Electric starting kit (250)	Kit démarrage électronique (250)	Elektronisch Anlasser Kit (250)	Kit arranque electrónico (250)	
<b>K</b>	2		1	Kit avviamento elettrico (450-510)	Electric starting kit (450-510)	Kit démarrage électronique (450-510)	Elektronisch Anlasser Kit (450-510)	Kit arranque electrónico (450-510)	
	3	8000 56444	8	Fascetta (L=188 mm)	Clamp (L=188 mm)	Collier (L=188 mm)	Schelle (L=188 mm)	Banda (L=188 mm)	
	4	8000 56783	5	Fascetta (L=142mm)	Clamp (L=142mm)	Collier (L=142mm)	Schelle (L=142mm)	Banda (L=142mm)	
	5	8000 58207	2	Passacavo	Fairlead	Passe-câble	Kabelführung	Prensa-cable	
	6	8000 A6477	1	Tappo per connettore condensatore	Condenser connector plug	Bouchon pour le connecteur du condensateur	Verschluss für Kondensatorverbinder	Tapòn por conector condensador	
	7	8000 A1891	1	Batteria (6 Ah)	Battery (6 Ah)	Batterie (6 Ah)	Batterie (6 Ah)	Bateria (6 Ah)	
	8	8000 A1280	1	Spessore elastico	Rubber spacer	Entretoise	Distanzstück	Espesor	
	9	8000 A0071	1	Contenitore batteria	Battery holder	Conteneur batterie	Batterie Behaelter	Contenedor batería	
	10	8A00 41459	2	Perno	Pin	Pivot	Bolzen	Perno	
	11	8A00 06911	4	Rosetta	Washer	Rondelle	Scheibe	Arandela	
	12	8000 62705	2	Spinetta	Pin	Goupille	Stift	Clavija	
	13	8000 A0107	1	Condensatore	Condenser	Condensateur	Kondensator	Condensador	
	14	8000 A0994	1	Cavo batteria-teleruttore (250)	Battery-Remote switch cable (250)	Cable batterie-telerupteur (250)	Kabel Batterie-Fernshalter (250)	Cable Batería-Telerruptor (250)	
	14	8000 A0110	1	Cavo batteria-teleruttore (450-510)	Battery-Remote switch cable (450-510)	Cable batterie-telerupteur (450-510)	Kabel Batterie-Fernshalter (450-510)	Cable Batería-Telerruptor (450-510)	
	15	8000 A0995	1	Cavo motorino avviamento (250)	Starting motor cable (250)	Cable moteur demarrage (250)	Anlasser motor kabel (250)	Cable motor de arranque (250)	
	15	8000 A0111	1	Cavo motorino avviamento (450-510)	Starting motor cable (450-510)	Cable moteur demarrage (450-510)	Anlasser motor kabel (450-510)	Cable motor de arranque (450-510)	
	16	8000 91115	1	Teleruttore avviamento	Remote switch	Telerupteur	Fernshalter	Telerruptor	
	17	8SA0 67545	2	Vite	Screw	Vis	Schraube	Tornillo	
	18	8000 47472	1	Fusibile (15A)	Fuse (15A)	Fusible (15A)	Sicherung (15A)	Fusible (15A)	
	27	8000 88181	1	Elastico	Elastic	Elastique	Elastisch	Elástico	
	28	8000 A0731	1	Pulsante arresto motore	Engine stop button	Poussoir arret moteur	Knopf	Pùlsador parada motor	

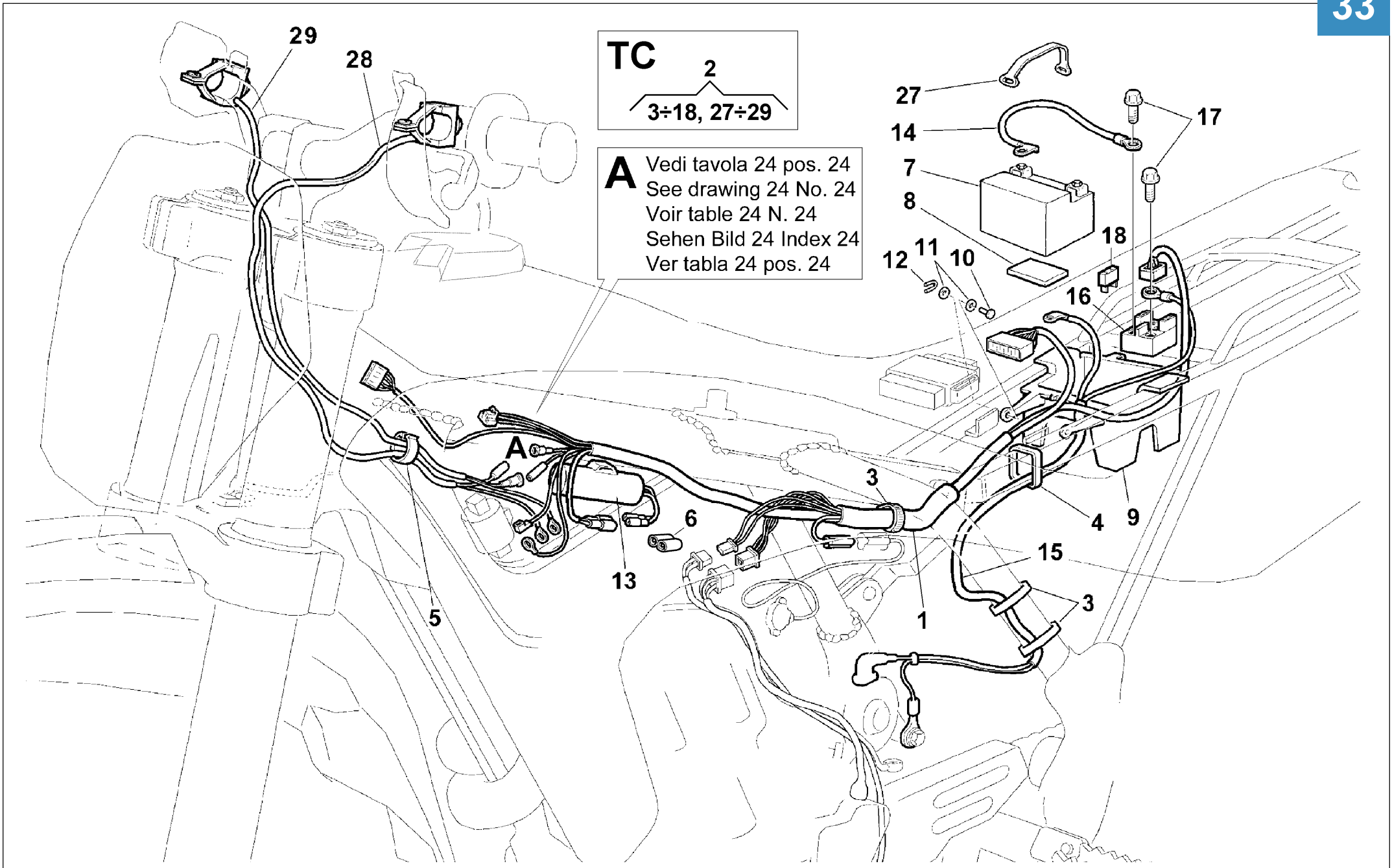

**TC**  
2  
3÷18, 27÷29

**A** Vedi tavola 24 pos. 24  
See drawing 24 No. 24  
Voir table 24 N. 24  
Sehen Bild 24 Index 24  
Ver tabla 24 pos. 24

Note Notes Notes Marke Notas	Pos. No. N. Index Pos.	N. Cod. Code No. Nr. Code Code Nr N. Cod.	Q.tà Q.ty M.ge C.ad	DENOMINAZIONE	NAME	DESIGNATION	BESHREIBUNG	DENOMINACION	Validità Validity Validité Gültig Validez
<b>Kk</b>	28	8000 96828	1	Pulsante arresto motore	Engine stop button	Poussoir arret moteur	Knopf	Pùlsador parada motor	
	29	8000 A0732	1	Pulsante avviamento motore	Engine start button	Poussoir demarrage moteur	Knopf	Pùlsador arranque motor	
<b>k</b>				Parte del kit cod. 8000 A6487 Tavola 2 pos. 10	Contained in kit 8000 A6487 drawing 2 no.10	Contenu in kit no. 8000 A6487 table 2 n. 10	Im Kit Code 8000 A6487 Bild 2 Index 10	Contenido en kit 8000 A6487 tabla 2 pos.10	
<b>K</b>				Parte del kit cod. 8000 A6488 Tavola 2 pos. 10	Contained in kit 8000 A6488 drawing 2 no.10	Contenu in kit no. 8000 A6488 table 2 n. 10	Im Kit Code 8000 A6488 Bild 2 Index 10	Contenido en kit 8000 A6488 tabla 2 pos.10	

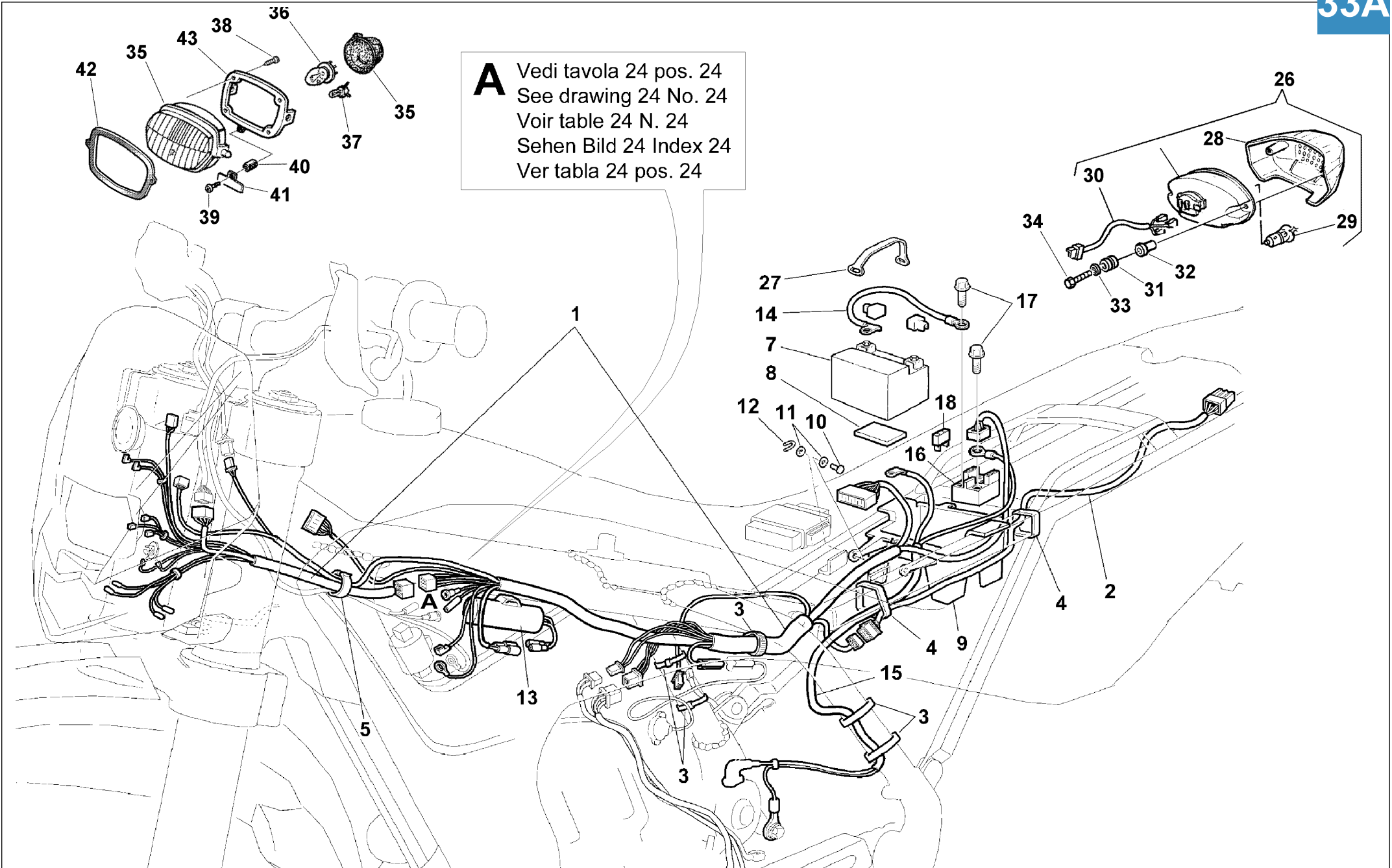

**A** Vedi tavola 24 pos. 24  
See drawing 24 No. 24  
Voir table 24 N. 24  
Sehen Bild 24 Index 24  
Ver tabla 24 pos. 24



Note Notes Notas	Pos. No. N. Index Pos.	N. Cod. Code No. Nr. Code Code Nr N. Cod.	Q.tà Q.ty Q.te M.ge C.ad	DENOMINAZIONE	NAME	DESIGNATION	BESHREIBUNG	DENOMINACION	Validità Validity Validité Gültig Validez
	1	8000 A5920	1	Gruppo principale cavi	Cable assy	Cables compl.	Kabel Kpl.	Grupo principal cables	
X	2	8000 70277	1	Cavo posteriore	Cable	Cable	Kabel	Cable	
	3	8000 56444	8	Fascetta (L=188 mm)	Clamp (L=188 mm)	Collier (L=188 mm)	Schelle (L=188 mm)	Banda (L=188 mm)	
	5	8000 58207	2	Passacavo	Fairlead	Passe-câble	Kabelführung	Prensa-cable	
X	6	8000 72494	1	Passacavo	Fairlead	Passe-câble	Kabelführung	Prensa-cable	
	7	8000 A1891	1	Batteria (6Ah)	Battery (6Ah)	Batterie (6Ah)	Batterie (6Ah)	Batería (6Ah)	
	8	8000 A1280	1	Spessore elastico	Rubber spacer	Entretoise	Distanzstück	Espesor	
	9	8000 A0071	1	Contenitore batteria	Battery holder	Conteneur batterie	Batterie Behaelter	Contenedor batería	
	10	8A00 41459	2	Perno	Pin	Pivot	Bolzen	Perno	
	11	8A00 06911	4	Rosetta	Washer	Rondelle	Scheibe	Arandela	
	12	8000 62705	2	Spinetta	Pin	Goupille	Stift	Clavija	
	13	8000 A0107	1	Condensatore	Condenser	Condensateur	Kondensator	Condensador	
	14	8000 A0110	1	Cavo batteria-teleruttore	Battery-Remote switch cable	Cable batterie-telerupteur	Kabel Batterie-Fernshalter	Cable Batería-Telerruptor	
	15	8000 A0111	1	Cavo motorino avviamento	Starting motor cable	Cable moteur demarrage	Anlasser motor kabel	Cable motor de arranque	
	16	8000 91115	1	Teleruttore avviamento	Remote switch	Telerupteur	Fernshalter	Telerruptor	
	17	8SA0 67545	2	Vite	Screw	Vis	Schraube	Tornillo	
	18	8000 47472	1	Fusibile (15A)	Fuse (15A)	Fusible (15A)	Sicherung (15A)	Fusible (15A)	
X	26	8A00 88873	1	Fanale posteriore completo	Tail light	Feux arrière	Hinterleuchte	Faro trasero	
	27	8000 88181	1	Elastico	Elastic	Elastique	Elastisch	Elástico	
X	28	8A00 94119	1	Lente	Lens	Loupe	Linse	Lente	
X	29	8A00 18246	1	Lampada (12V-5/12 W)	Lamp (12V-5/12 W)	Lampe (12V-5/12 W)	Lampe (12V-5/12 W)	Lamparilla (12V-5/12 W)	
X	30	8000 94121	1	Cablaggio	Cable	Cable	Kabel	Cable	
X	31	8000 18048	2	Gommino	Rubber pad	Pièce caoutchouc	Gummstück	Junta de goma	
X	32	8A00 94120	2	Distanziale	Spacer	Entretoise	Distanzstück	Separador	
X	33	8A00 20373	2	Rosetta piana	Washer	Rondelle	Scheibe	Arandela	
X	34	8000 A0953	2	Vite	Screw	Vis	Schraube	Tornillo	
X	35	8000 A5567	1	Gruppo ottico	Optical group	Groupe optique	Optische Gruppe	Grupo óptico	
X	36	8000 20137	1	Lampada (12V-35/35 W)	Lamp (12V-35/35 W)	Lampe (12V-35/35 W)	Lampe (12V-35/35 W)	Lamparilla (12V-35/35 W)	
X	37	8000 26694	1	Lampada (12V-3 W)	Lamp (12V-3 W)	Lampe (12V-3 W)	Lampe (12V-3 W)	Lamparilla (12V-3 W)	
X	38	8000 A6635	4	Vite	Screw	Vis	Schraube	Tornillo	
X	39	8A00 A6635	1	Vite	Screw	Vis	Schraube	Tornillo	
X	40	8000 A1051	1	Distanziale	Spacer	Entretoise	Distanzstück	Separador	
X	41	8000 A1052	1	Piastrina	Plate	Plaque	Platte	Placa	

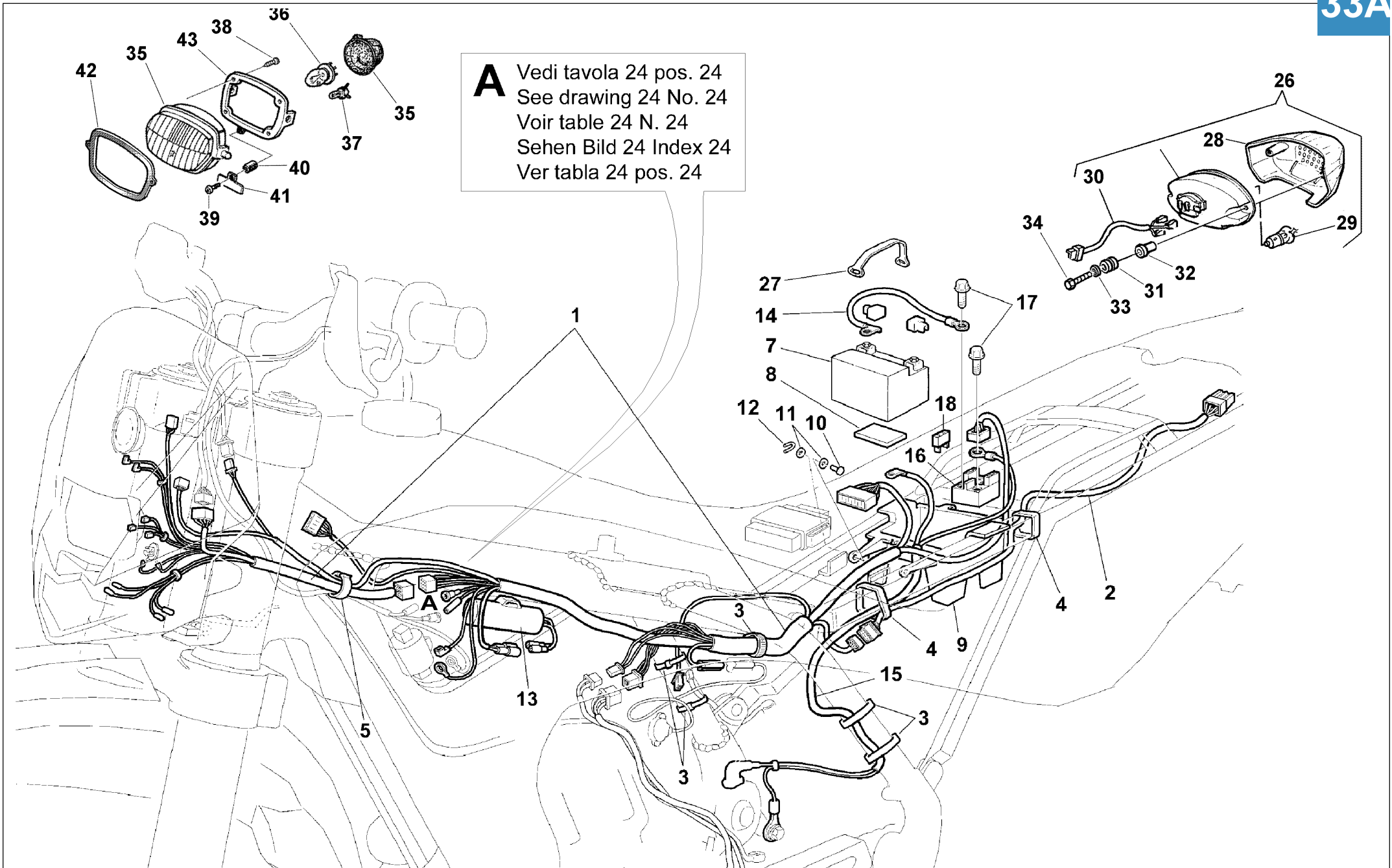

**A** Vedi tavola 24 pos. 24  
 See drawing 24 No. 24  
 Voir table 24 N. 24  
 Sehen Bild 24 Index 24  
 Ver tabla 24 pos. 24













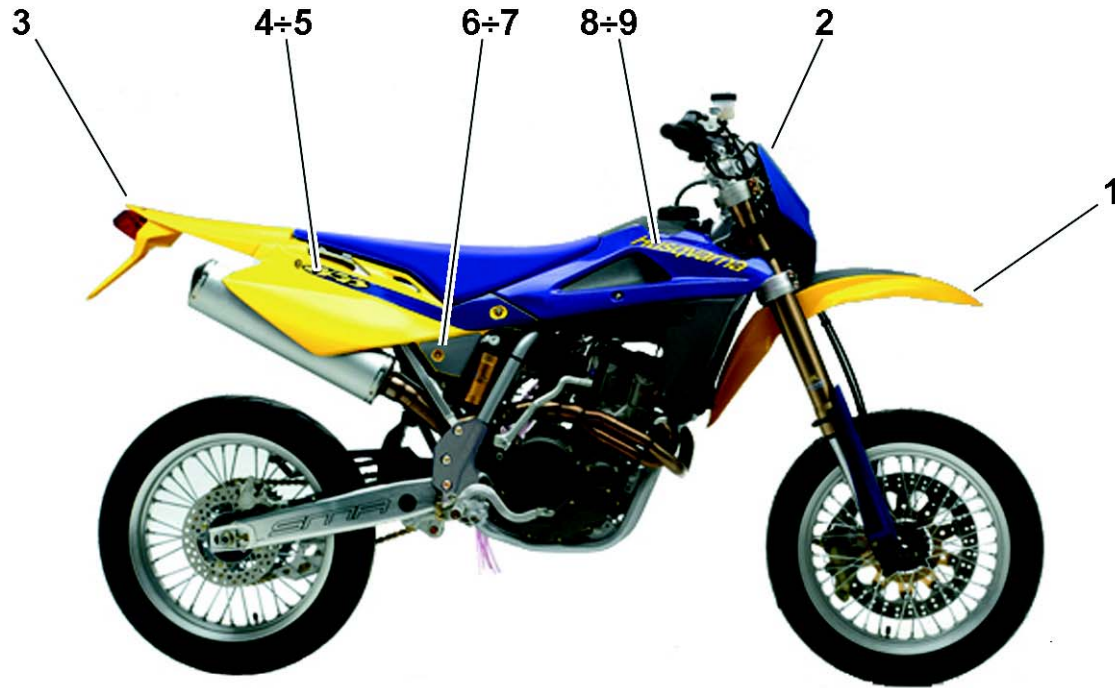





Note Notes Marke Notas	Pos. No. N. Index Pos.	N. Cod. Code No. Nr. Code Code Nr N. Cod.	Q.tà Q.ty Q.te M.ge C.ad	DENOMINAZIONE	NAME	DESIGNATION	BESHREIBUNG	DENOMINACION	Validità Validity Validité Gültig Validez
	1	8000 A4915	1	Decal per parafango anteriore	Transfer	Decalcomania	Abziehbild	Calcomania	
	2	8000 A4326	1	Decal per portanumero	L.H. transfer	Decalcomania G.	Abziehbild L.	Calcomania izq.	
	3	8000 A4722	1	Decal parafango posteriore	Transfer	Decalcomania	Abziehbild	Calcomania	
	4	8000 A6284	1	Decal per fianchetto sup. Dx	R.H. upper transfer	Decalcomania sup. D.	Unterabziehbild R.	Calcomania sup. der.	
	5	8000 A6283	1	Decal per fianchetto sup. Sx	L.H. upper transfer	Decalcomania sup. G.	Unterabziehbild L.	Calcomania sup. izq.	
	6	8000 A4842	1	Decal per fianchetto inf. Dx	R.H. lower transfer	Decalcomania inf. D.	Oberabziehbild R.	Calcomania inf. der.	
	7	8000 A4841	1	Decal per fianchetto inf. Sx	L.H. lower transfer	Decalcomania inf. G.	Oberabziehbild L.	Calcomania inf. izq.	
	8	8000 A6282	1	Decal per convogliatore Dx	R.H. transfer	Decalcomania D.	Abziehbild R.	Calcomania der.	
	9	8000 A6281	1	Decal per convogliatore Sx	L.H. transfer	Decalcomania G.	Abziehbild L.	Calcomania izq.	

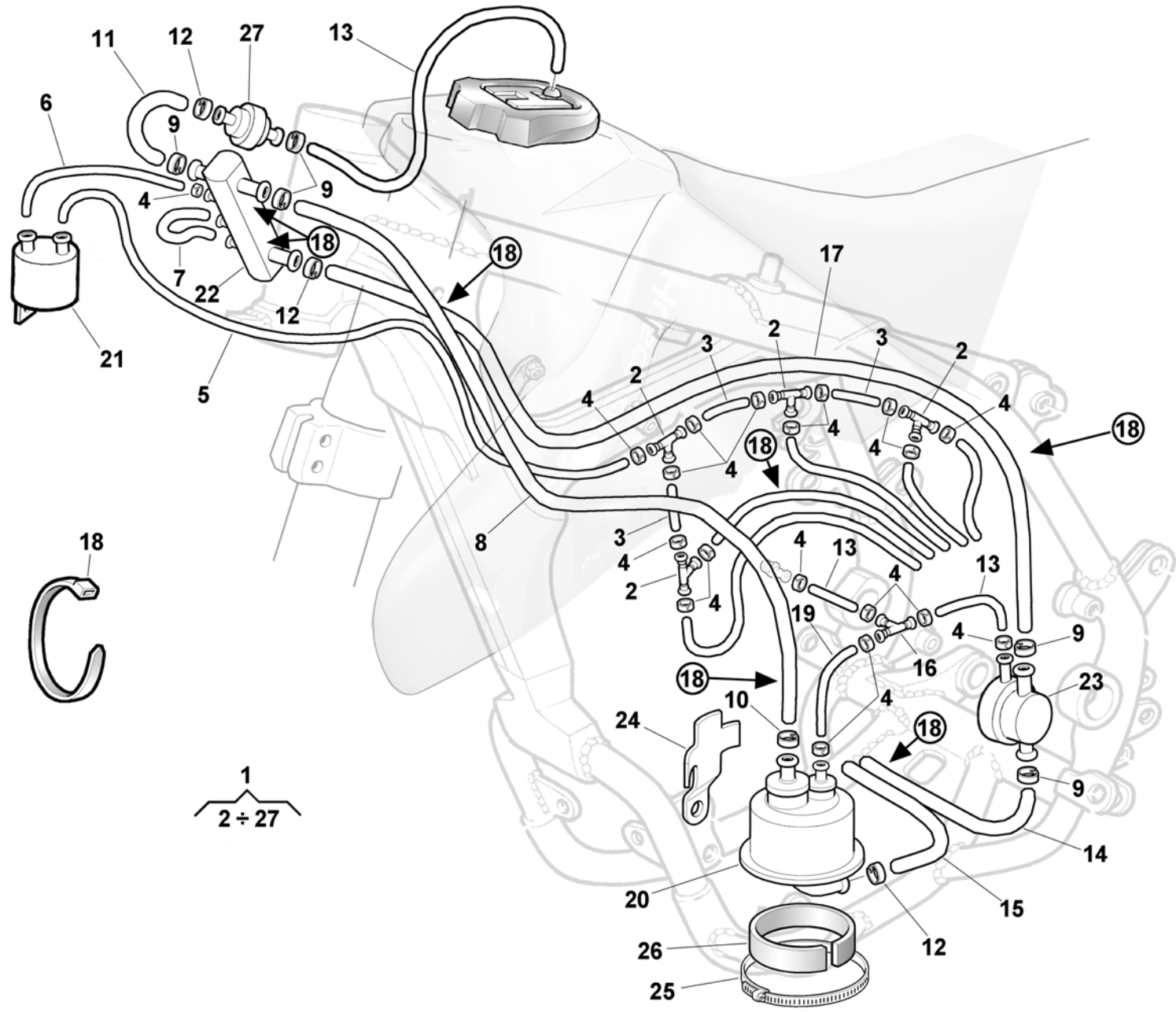



Note Notes Notas	Pos. No. N. Index Pos.	N. Cod. Code No. Nr. Code Code Nr N. Cod.	Q.tà Q.ty Q.te M.ge C.ad	DENOMINAZIONE	NAME	DESIGNATION	BESHREIBUNG	DENOMINACION	Validità Validity Validité Gültig Validez
<b>D</b>	1	8000 A7271	1	Kit canister (U.S.A.)	Canister kit (U.S.A.)	Kit canister (U.S.A.)	Kit Canister (U.S.A.)	Kit canister (U.S.A.)	
	2	8000 95630	4	Connettore a 3 vie	3 Ways Union	Connecteur	Kopplungsstuch	Conector	
	3	8E00 A5928	3	Tubazione (30 mm)	Hose (30 mm)	Tuyau (30 mm)	Schlauch (30 mm)	Tube (30 mm)	
	4	8C00 95276	19	Fascetta	Clamp	Collier	Schelle	Abrazadera	
	5	8M00 A5928	1	Tubazione (580 mm)	Hose (580 mm)	Tuyau (580 mm)	Schlauch (580 mm)	Tube (580 mm)	
	6	8000 A5929	1	Tubazione (240 mm)	Hose (240 mm)	Tuyau (240 mm)	Schlauch (240 mm)	Tube (240 mm)	
	7	8A00 A5929	1	Tubazione (80 mm)	Hose (80 mm)	Tuyau (80 mm)	Schlauch (80 mm)	Tube (80 mm)	
	8	8F00 A5927	1	Tubazione (840 mm)	Hose (840 mm)	Tuyau (840 mm)	Schlauch (840 mm)	Tube (840 mm)	
	9	8B00 95276	5	Fascetta	Clamp	Collier	Schelle	Abrazadera	
	10	8F00 95276	1	Fascetta	Clamp	Collier	Schelle	Abrazadera	
	11	8000 A5927	1	Tubazione (350 mm)	Hose (350 mm)	Tuyau (350 mm)	Schlauch (350 mm)	Tube (350 mm)	
	12	8E00 95276	3	Fascetta	Clamp	Collier	Schelle	Abrazadera	
	13	8000 A5928	3	Tubazione (50 mm)	Hose (50 mm)	Tuyau (50 mm)	Schlauch (50 mm)	Tube (50 mm)	
	14	8C00 A5927	1	Tubazione (200 mm)	Hose (200 mm)	Tuyau (200 mm)	Schlauch (200 mm)	Tube (200 mm)	
	15	8G00 A5927	1	Tubazione (380 mm)	Hose (380 mm)	Tuyau (380 mm)	Schlauch (380 mm)	Tube (380 mm)	
	16	8000 95630	1	Connettore a 3 vie	3 Ways Union	Connecteur	Kopplungsstuch	Conector	
	17	8D00 A5927	1	Tubazione (780 mm)	Hose (780 mm)	Tuyau (780 mm)	Schlauch (780 mm)	Tube (780 mm)	
	18	8000 56444	10	Fascetta	Clamp	Collier	Schelle	Abrazadera	
	19	8N00 A5928	1	Tubazione (230 mm)	Hose (230 mm)	Tuyau (230 mm)	Schlauch (230 mm)	Tube (230 mm)	
	20	8000 93782	1	Canister	Canister	Canister	Canister	Canister	
	21	8000 95102	1	Separatore vapori	Vapour separator	Séparateur	Separator	Separador	
	22	8000 95631	1	Connettore a 6 vie	6 Ways Union	Connecteur	Kopplungsstuch	Conector	
	23	8000 95103	1	Valvola a depressione	Depression valve	Soupape	Ventil	Valvula	
	24	8000 A5924	1	Piastrina	Plate	Plaquette	Plättchen	Placa	
	25	8000 63298	1	Fascetta	Clamp	Collier	Schelle	Abrazadera	
	26	8000 95775	1	Gomma adesiva	Pad	Tampon	Stopfen	Tampòn	
	27	8000 A5925	1	Valvola di ventilazione	Vent valve	Soupape	Ventil	Valvula	

DISEGNO DRAWING DESSIN ZEICHNUNG DIBUJO	TAVOLA DRAWING TABLE BILD TABLA	INDEX NO. POS. N. INDICE	DISEGNO DRAWING DESSIN ZEICHNUNG DIBUJO	TAVOLA DRAWING TABLE BILD TABLA	INDEX NO. POS. N. INDICE	DISEGNO DRAWING DESSIN ZEICHNUNG DIBUJO	TAVOLA DRAWING TABLE BILD TABLA	INDEX NO. POS. N. INDICE	DISEGNO DRAWING DESSIN ZEICHNUNG DIBUJO	TAVOLA DRAWING TABLE BILD TABLA	INDEX NO. POS. N. INDICE	DISEGNO DRAWING DESSIN ZEICHNUNG DIBUJO	TAVOLA DRAWING TABLE BILD TABLA	INDEX NO. POS. N. INDICE	DISEGNO DRAWING DESSIN ZEICHNUNG DIBUJO	TAVOLA DRAWING TABLE BILD TABLA	INDEX NO. POS. N. INDICE
1513 07001	19	25	66N0 21202	12	19	8000 22966	30A	23	8000 38521	23	9	8000 45495	27	27	8000 56444	33A	3
1513 41401	28	12	66N0 21204	15	36	8000 23107	4	46	8000 38711	16	35	8000 45495	32	24	8000 56444	38	18
1513 71301	14	10	66N0 21205	7	18	8000 23107	12	34	8000 38711	16A	35	8000 46664	29A	3	8000 56462	17	17
1514 03203	28	11	66N0 21206	16A	64	8000 23374	4	31	8000 38712	16	36	8000 46893	19	57	8000 56767	31	28
1515 50601	21	32	66N0 21208	15	13	8000 24952	9	5	8000 38712	16A	36	8000 46893	19	63	8000 56768	31	27
1517 94702	1	1	66N0 21211	16	16	8000 25082	12	8	8000 38728	16A	63	8000 46893	26	5	8000 56783	33	4
1519 84701	1	13	66N0 21211	16	26	8000 26694	33A	37	8000 38748	27	21	8000 46893	26	28	8000 56920	1	21
1610 77601	8	16	66N0 21211	16A	16	8000 26884	12	22	8000 40007	17	11	8000 46893	26	11	8000 57155	25	26
1610 77703	8	14	66N0 21211	16A	26	8000 27122	17	7	8000 40427	17	37	8000 46893	28	17	8000 57155	29	23
1610 77703	9	16	66N0 21258	10	4	8000 28327	8	27	8000 40717	26	44	8000 47472	33	18	8000 57155	29A	21
1611 08401	15	44	66N0 21270	30	22	8000 28327	9	19	8000 40718	18	8	8000 47472	33A	18	8000 57196	5	3
1614 59002	8	17	66N0 21270	30A	22	8000 28929	27	30	8000 40796	31	17	8000 47708	4	32	8000 57196	5	4
1615 09801	7	19	66N0 21272	31	24	8000 29171	12	33	8000 41459	19	48	8000 47763	4	18	8000 57196	16	14
1615 35501	3	5	66N0 21312	9	13	8000 30319	28	21	8000 41693	16	24	8000 47773	12	13	8000 57196	16A	14
1615 35801	3	12	69N4 29004	30A	9	8000 31772	16	6	8000 41693	16A	24	8000 48236	6	13	8000 58207	33	5
1615 35902	4	41	69N4 29005	31	7	8000 31772	16A	6	8000 41862	32	10	8000 48802	28	18	8000 58207	33A	5
1615 38801	6	19	6BN0 21507	15	47	8000 32388	21	56	8000 42022	22	31	8000 48814	26	23	8000 59289	21	24
1617 95501	4	4	8000 01199	27	6	8000 33288	29A	9	8000 42022	22A	31	8000 49035	31	4	8000 59801	17	22
1617 95501	17	5	8000 01412	23	15	8000 33373	19	20	8000 42022	23	6	8000 49036	30	4	8000 59802	17	20
1617 95502	12	10	8000 01688	31	3	8000 33718	12	17	8000 42023	23	12	8000 49654	29	16	8000 59803	17	19
60N1 01059	21	60	8000 05876	15	32	8000 34317	4	21	8000 42278	17	2	8000 49792	4	2	8000 59977	8	13
60N1 01222	20	62	8000 07719	10	12	8000 34317	6	11	8000 42345	29A	4	8000 50005	24	8	8000 60233	20	59
60N1 01223	20	62	8000 07719	11	5	8000 34317	7	7	8000 42349	25	21	8000 50453	17	31	8000 60233	20A	59
60N1 01224	20A	62	8000 08536	21	55	8000 34317	17	9	8000 42676	16	54	8000 51746	8	7	8000 60234	20	60
60N1 02482	13	3	8000 10777	31	3	8000 34451	8	11	8000 42676	16A	54	8000 51746	9	18	8000 60234	20A	60
60N1 02483	14	9	8000 13346	30	3	8000 34609	12	23	8000 42677	16	55	8000 53155	20	61	8000 60577	15	48
60N1 02488	14	7	8000 17040	9	8	8000 35531	19	34	8000 42677	16A	55	8000 53155	20A	61	8000 60873	27	32
60N1 02510	6	9	8000 17810	21	21	8000 35763	15	28	8000 43391	19	29	8000 53259	25	33	8000 60898	19	4
60N1 02510	27	18	8000 18048	33A	31	8000 36137	13	4	8000 43567	8	6	8000 53259	29	20	8000 61078	25	14
60N3 02463	13A	3	8000 18921	29A	14	8000 36137	21	40	8000 43592	27	5	8000 53259	29A	17	8000 61275	7	20
62N0 15678	12	29	8000 19965	4	39	8000 36380	15	45	8000 43928	19	31	8000 53339	17	10	8000 61313	15	16
62N0 15679	12	31	8000 20137	33A	36	8000 36653	15	50	8000 43928	21	37	8000 54073	31	4	8000 61313	26	4
62N1 15504	19	49	8000 20536	21	14	8000 36726	32	8	8000 43928	21	44	8000 54700	4	27	8000 61314	20	63
62N1 15547	26	45	8000 20536	21	61	8000 36786	12	32	8000 43928	31	18	8000 55699	7	13	8000 61314	20A	63
62N1 15548	26	39	8000 21375	12	15	8000 36856	6	3	8000 44240	21	33	8000 55902	25	4	8000 61355	20	53
62N1 15549	18	10	8000 21480	25	25	8000 36857	6	4	8000 44240	21	46	8000 55903	25	13	8000 61355	20A	53
62N4 15548	32	12	8000 21480	29	24	8000 37140	17	33	8000 44240	26	49	8000 56359	26	48	8000 61355	26	13
64N1 20048	19	50	8000 21480	29A	22	8000 37745	27	10	8000 44240	28	16	8000 56377	25	6	8000 62705	33	12
64N1 20068	19	12	8000 22373	16	21	8000 38287	15	46	8000 44240	32	4	8000 56443	20	72	8000 62705	33A	12
64N1 20068	25	7	8000 22373	16A	21	8000 38350	6	2	8000 44298	4	45	8000 56443	20A	72	8000 62725	7	13
66N0 21197	32	13	8000 22551	25	3	8000 38520	16	29	8000 45194	4	42	8000 56444	17	42	8000 62725	8	30
66N0 21200	32	13	8000 22966	30	23	8000 38520	16A	29	8000 45495	21	35	8000 56444	33	3	8000 62725	20A	68

DISEGNO DRAWING DESSIN ZEICHNUNG DIBUJO	TAVOLA DRAWING TABLE BILD TABLA	INDEX NO. POS. N. INDICE	DISEGNO DRAWING DESSIN ZEICHNUNG DIBUJO	TAVOLA DRAWING TABLE BILD TABLA	INDEX NO. POS. N. INDICE	DISEGNO DRAWING DESSIN ZEICHNUNG DIBUJO	TAVOLA DRAWING TABLE BILD TABLA	INDEX NO. POS. N. INDICE	DISEGNO DRAWING DESSIN ZEICHNUNG DIBUJO	TAVOLA DRAWING TABLE BILD TABLA	INDEX NO. POS. N. INDICE	DISEGNO DRAWING DESSIN ZEICHNUNG DIBUJO	TAVOLA DRAWING TABLE BILD TABLA	INDEX NO. POS. N. INDICE	DISEGNO DRAWING DESSIN ZEICHNUNG DIBUJO	TAVOLA DRAWING TABLE BILD TABLA	INDEX NO. POS. N. INDICE
8000 62725	21	47	8000 62729	10	7	8000 63885	3	2	8000 69429	26	20	8000 73011	12	30	8000 82948	12	2
8000 62725	25	18	8000 62729	11	4	8000 65411	21	31	8000 69429	26	22	8000 73140	19	5	8000 83395	20	3
8000 62725	29A	12	8000 62729	15	2	8000 65412	21	9	8000 69429	26	26	8000 73500	8	15	8000 83395	20A	3
8000 62726	16	43	8000 62729	20	40	8000 65437	24	21	8000 69429	27	29	8000 73500	9	15	8000 84938	30	13
8000 62726	16	48	8000 62729	20A	40	8000 65464	31	28	8000 69549	18	2	8000 73832	21	64	8000 84938	30A	13
8000 62726	16A	43	8000 62729	29	37	8000 65884	8	10	8000 70024	18	7	8000 73834	26	43	8000 85395	9	11
8000 62726	16A	48	8000 62729	29A	15	8000 66181	29A	7	8000 70216	16	59	8000 73894	25	1	8000 85493	16	47
8000 62726	18	9	8000 62730	3	17	8000 66525	8	19	8000 70216	16A	59	8000 74016	21	38	8000 85493	16A	47
8000 62726	22	24	8000 62730	4	28	8000 66525	12	24	8000 70277	33A	2	8000 74507	32	7	8000 85495	16	44
8000 62726	22A	24	8000 62730	10	15	8000 66525	16	56	8000 70696	25	5	8000 74836	4	6	8000 85495	16A	44
8000 62726	26	29	8000 62730	17	6	8000 66525	16A	56	8000 71007	16	38	8000 74842	20	82	8000 86004	17	38
8000 62726	26	29	8000 62730	19	62	8000 66651	19	47	8000 71007	16A	38	8000 74842	20	82	8000 86107	16	46
8000 62726	28	13	8000 62731	8	24	8000 66652	19	45	8000 71008	16	39	8000 74842	20A	82	8000 86107	16A	46
8000 62726	31	15	8000 62731	21	29	8000 66774	8	23	8000 71008	16A	39	8000 74842	20A	82	8000 86137	23	16
8000 62726	32	23	8000 62731	21	45	8000 66802	1	7	8000 71009	16	40	8000 75160	21	51	8000 86140	23	7
8000 62727	3	13	8000 62732	19	3	8000 66973	8	26	8000 71009	16A	40	8000 75166	21	39	8000 86176	23	3
8000 62727	14	5	8000 62732	19	51	8000 67744	3	11	8000 71010	16	34	8000 76283	21	11	8000 86177	23	2
8000 62727	14	14	8000 62733	20A	75	8000 67997	20	68	8000 71010	16	41	8000 76338	25	10	8000 86732	15	5
8000 62727	15	11	8000 62733	29	12	8000 67997	21	14	8000 71010	16A	34	8000 76687	24	3	8000 86878	10	14
8000 62727	24	19	8000 62733	29	13	8000 67997	21	57	8000 71010	16A	41	8000 76688	24	2	8000 86951	17	35
8000 62727	25	12	8000 62795	21	36	8000 67997	32	5	8000 71445	25	27	8000 77373	20	20	8000 86953	16	25
8000 62727	26	19	8000 62795	21	43	8000 68490	29A	8	8000 71445	29	14	8000 77373	20A	20	8000 86953	16A	25
8000 62727	26	47	8000 62796	19	19	8000 69056	19	3	8000 71445	29A	32	8000 78337	32	6	8000 87243	19	25
8000 62727	27	28	8000 62796	20	2	8000 69056	19	23	8000 71578	24	26	8000 78338	32	11	8000 87289	15	4
8000 62727	28	14	8000 62796	20A	2	8000 69056	19	59	8000 71578	32	27	8000 78339	32	26	8000 87299	16	37
8000 62727	32	3	8000 62796	20A	75	8000 69111	19	21	8000 71620	21	13	8000 78340	32	25	8000 87299	16A	37
8000 62728	4	38	8000 63298	38	25	8000 69125	25	2	8000 71621	21	53	8000 78442	17	1	8000 87736	20	56
8000 62728	10	15	8000 63312	19	39	8000 69148	26	15	8000 71622	21	2	8000 79015	1	11	8000 87736	20A	56
8000 62728	10	18	8000 63312	21	54	8000 69149	26	7	8000 71623	21	19	8000 79065	29	21	8000 87745	20	73
8000 62728	12	11	8000 63821	16	9	8000 69150	19	18	8000 72425	12	21	8000 79066	25	22	8000 87810	21	10
8000 62728	14	7	8000 63822	16	4	8000 69282	20	69	8000 72426	12	20	8000 79066	29	22	8000 88181	33	27
8000 62728	14	14	8000 63822	16A	4	8000 69282	20A	54	8000 72427	12	7	8000 79075	25	28	8000 88181	33A	27
8000 62728	16	61	8000 63827	16	62	8000 69282	21	52	8000 72494	26	37	8000 79077	17	32	8000 88231	22	21
8000 62728	16A	61	8000 63827	16A	62	8000 69315	20	57	8000 72494	33A	6	8000 79099	29	7	8000 88231	22A	21
8000 62728	17	21	8000 63828	16	62	8000 69315	20A	57	8000 72641	18	3	8000 79789	31	28	8000 88244	16A	3
8000 62728	18	13	8000 63828	16A	62	8000 69429	18	5	8000 72826	16	51	8000 79790	31	28	8000 88246	16A	8
8000 62728	24	17	8000 63829	16	62	8000 69429	19	16	8000 72826	16A	51	8000 80260	20	54	8000 88247	16A	11
8000 62728	25	12	8000 63829	16A	62	8000 69429	20A	69	8000 72868	21	42	8000 80260	20A	83	8000 88254	16A	17
8000 62728	26	11	8000 63830	16	62	8000 69429	22	23	8000 72869	21	41	8000 81508	6	6	8000 88255	16	10
8000 62728	26	14	8000 63830	16A	62	8000 69429	22A	23	8000 72873	21	5	8000 81519	6	8	8000 88255	16A	65
8000 62728	26	18	8000 63831	16	62	8000 69429	25	36	8000 72874	21	28	8000 81628	21	63	8000 88602	26	42
8000 62728	26	35	8000 63831	16A	62	8000 69429	26	17	8000 72875	21	27	8000 81675	12	25	8000 89069	32	14

DISEGNO DRAWING DESSIN ZEICHNUNG DIBUJO	TAVOLA DRAWING TABLE BILD TABLA	INDEX NO. POS. N. INDICE	DISEGNO DRAWING DESSIN ZEICHNUNG DIBUJO	TAVOLA DRAWING TABLE BILD TABLA	INDEX NO. POS. N. INDICE	DISEGNO DRAWING DESSIN ZEICHNUNG DIBUJO	TAVOLA DRAWING TABLE BILD TABLA	INDEX NO. POS. N. INDICE	DISEGNO DRAWING DESSIN ZEICHNUNG DIBUJO	TAVOLA DRAWING TABLE BILD TABLA	INDEX NO. POS. N. INDICE	DISEGNO DRAWING DESSIN ZEICHNUNG DIBUJO	TAVOLA DRAWING TABLE BILD TABLA	INDEX NO. POS. N. INDICE	DISEGNO DRAWING DESSIN ZEICHNUNG DIBUJO	TAVOLA DRAWING TABLE BILD TABLA	INDEX NO. POS. N. INDICE
8000 89089	22	11	8000 91984	14	3	8000 96908	19	11	8000 98497	22	16	8000 99660	17	23	8000 99858	12	1
8000 89089	22A	11	8000 92414	31	9	8000 96928	30	11	8000 98497	22A	16	8000 99661	17	27	8000 99859	29	38
8000 89572	31	26	8000 92612	31	5	8000 96928	30A	11	8000 98498	22	17	8000 99674	29	11	8000 99860	12	4
8000 91115	33	16	8000 92797	30	12	8000 96930	30	21	8000 98498	22A	17	8000 99684	4	49	8000 99861	12	5
8000 91115	33A	16	8000 92797	30A	12	8000 96932	30	18	8000 98499	22	18	8000 99687	4	44	8000 99862	12	9
8000 91238	22	4	8000 92797	31	11	8000 96933	30	19	8000 98499	22A	18	8000 99694	7	8	8000 99863	12	12
8000 91238	22A	4	8000 93011	32	30	8000 96933	30A	19	8000 98503	22	19	8000 99698	7	14	8000 99864	12	16
8000 91288	1	10	8000 93036	29	8	8000 96934	29	17	8000 98503	22A	19	8000 99699	7	15	8000 99866	12	26
8000 91289	1	12	8000 93072	31	21	8000 96938	31	12	8000 98504	22	6	8000 99700	7	16	8000 99868	14	8
8000 91474	20	13	8000 93124	23	18	8000 96940	31	19	8000 98504	22A	6	8000 99701	7	17	8000 99869	3	1
8000 91474	20A	13	8000 93283	20	70	8000 96941	21	50	8000 98520	22	6	8000 99702	7	10	8000 99870	3	3
8000 91479	20	19	8000 93283	20A	70	8000 96944	21	18	8000 98520	22A	6	8000 99703	7	12	8000 99871	3	4
8000 91479	20A	19	8000 93782	38	20	8000 96997	1	19	8000 98552	20	22	8000 99704	8	21	8000 99877	7	5
8000 91480	20	48	8000 93915	4	43	8000 97025	21	58	8000 98552	20A	22	8000 99705	8	22	8000 99880	7	8
8000 91480	20A	48	8000 94121	33A	30	8000 97050	23	5	8000 98569	22	6	8000 99708	17	12	8000 99887	4	37
8000 91519	20	55	8000 94126	29	4	8000 97615	1	22	8000 98569	22A	6	8000 99711	4	17	8000 99915	5	5
8000 91519	20A	55	8000 94127	29	5	8000 97749	20	77	8000 98781	20A	41	8000 99711	12	28	8000 99916	5	7
8000 91525	30A	6	8000 94128	29	6	8000 97749	20A	77	8000 98782	20	78	8000 99721	32	17	8000 99919	16	27
8000 91552	12	6	8000 94342	26	50	8000 97750	20	76	8000 98782	20A	78	8000 99738	16	33	8000 99928	24	32
8000 91553	4	40	8000 94595	26	46	8000 97750	20A	76	8000 98783	20	79	8000 99738	16A	33	8000 99933	6	21
8000 91555	8	20	8000 94754	30A	8	8000 97941	8	3	8000 98783	20A	79	8000 99739	16	42	8000 99953	6	10
8000 91559	16	49	8000 94757	31	6	8000 97941	9	3	8000 98784	20	80	8000 99739	16A	42	8000 99956	15	27
8000 91559	16A	49	8000 94849	25	26	8000 97943	15	1	8000 98784	20A	80	8000 99741	16	57	8000 99957	15	30
8000 91564	17	3	8000 95102	38	21	8000 98116	3	6	8000 98785	20	81	8000 99741	16A	57	8000 99958	15	3
8000 91565	17	8	8000 95103	38	23	8000 98118	20	64	8000 98785	20A	81	8000 99744	16	60	8000 99960	15	7
8000 91566	4	24	8000 95260	20	41	8000 98149	16	30	8000 98786	20	6	8000 99744	16A	60	8000 99966	15	40
8000 91568	4	14	8000 95260	20A	41	8000 98149	16A	30	8000 98786	20A6		8000 99775	32	15	8000 99973	15	49
8000 91578	4	12	8000 95630	38	2	8000 98186	13	27	8000 98787	20	5	8000 99782	16	3	8000 A0008	3	4
8000 91578	4	12	8000 95630	38	16	8000 98196	13	23	8000 98787	20A5		8000 99783	16	7	8000 A0009	3	6
8000 91579	4	13	8000 95631	38	22	8000 98209	24	6	8000 98789	20	21	8000 99784	16	8	8000 A0033	14	11
8000 91583	4	19	8000 95775	38	26	8000 98215	13	5	8000 98789	20A	21	8000 99787	16	13	8000 A0055	24	12
8000 91584	4	20	8000 96606	17	36	8000 98237	20	58	8000 98792	20	22	8000 99790	16	17	8000 A0071	33	9
8000 91586	4	23	8000 96643	20A	5	8000 98250	13	103	8000 98792	20A	22	8000 99833	4	15	8000 A0071	33A	9
8000 91587	4	25	8000 96645	20A	22	8000 98268	13	30	8000 98803	20A	21	8000 99834	4	19	8000 A0080	30	8
8000 91588	4	26	8000 96647	20A	41	8000 98272	13	36	8000 99613	19	58	8000 99837	4	24	8000 A0081	30	9
8000 91589	4	30	8000 96811	20	1	8000 98275	13	29	8000 99619	21	3	8000 99841	3	10	8000 A0085	31	6
8000 91602	8	9	8000 96813	20	4	8000 98489	22	5	8000 99625	32	17	8000 99846	8	2	8000 A0086	31	7
8000 91602	9	10	8000 96828	33	28	8000 98489	22A	5	8000 99632	30	16	8000 99846	9	2	8000 A0091	16	31
8000 91602	9	10	8000 96837	31	16	8000 98492	22	9	8000 99650	32	16	8000 99847	8	5	8000 A0092	16	32
8000 91976	14	4	8000 96838	30	10	8000 98492	22A	9	8000 99652	32	18	8000 99850	8	18	8000 A0107	33	13
8000 91977	14	1	8000 96897	20	4	8000 98496	22	15	8000 99658	17	15	8000 99855	10	6	8000 A0107	33A	13
8000 91978	14	6	8000 96907	19	6	8000 98496	22A	15	8000 99659	17	14	8000 99856	11	2	8000 A0110	33	14

DISEGNO DRAWING DESSIN ZEICHNUNG DIBUJO	TAVOLA DRAWING TABLE BILD TABLA	INDEX NO. POS. N. INDICE	DISEGNO DRAWING DESSIN ZEICHNUNG DIBUJO	TAVOLA DRAWING TABLE BILD TABLA	INDEX NO. POS. N. INDICE	DISEGNO DRAWING DESSIN ZEICHNUNG DIBUJO	TAVOLA DRAWING TABLE BILD TABLA	INDEX NO. POS. N. INDICE	DISEGNO DRAWING DESSIN ZEICHNUNG DIBUJO	TAVOLA DRAWING TABLE BILD TABLA	INDEX NO. POS. N. INDICE	DISEGNO DRAWING DESSIN ZEICHNUNG DIBUJO	TAVOLA DRAWING TABLE BILD TABLA	INDEX NO. POS. N. INDICE	DISEGNO DRAWING DESSIN ZEICHNUNG DIBUJO	TAVOLA DRAWING TABLE BILD TABLA	INDEX NO. POS. N. INDICE
8000 A0110	33A	14	8000 A0765	10	2	8000 A1280	33	8	8000 A1798	13A	19	8000 A3091	13A	5	8000 A4052	14	2
8000 A0111	33	15	8000 A0779	17	28	8000 A1280	33A	8	8000 A1799	13A	20	8000 A3104	19	2	8000 A4080	26	42
8000 A0111	33A	15	8000 A0811	29A	6	8000 A1281	17	41	8000 A1800	13A	17	8000 A3191	2	5	8000 A4092	20A	64
8000 A0227	32	6	8000 A0843	32	15	8000 A1300	16A	2	8000 A1801	13A	16	8000 A3191	20	7	8000 A4106	4	10
8000 A0228	32	11	8000 A0854	3	4	8000 A1302	16A	13	8000 A1802	13A	21	8000 A3195	34	1	8000 A4106	4	10
8000 A0229	32	25	8000 A0855	3	6	8000 A1316	16A	27	8000 A1803	13A	18	8000 A3195	36	1	8000 A4107	4	10
8000 A0230	32	26	8000 A0864	26	40	8000 A1322	16	1	8000 A1806	13A	8	8000 A3196	34	2	8000 A4135	4	12
8000 A0232	4	33	8000 A0865	2	6	8000 A1323	16	2	8000 A1808	13A	15	8000 A3196	36	2	8000 A4136	4	7
8000 A0266	19	53	8000 A0865	19	7	8000 A1324	16	3	8000 A1809	13A	9	8000 A3378	3	5	8000 A4136	4	7
8000 A0267	19	56	8000 A0870	28	5	8000 A1325	16	7	8000 A1891	33	7	8000 A3408	24	14	8000 A4137	4	7
8000 A0268	19	54	8000 A0871	28	6	8000 A1326	16	8	8000 A1891	33A	7	8000 A3409	24	23	8000 A4143	13	1
8000 A0269	19	55	8000 A0873	28	20	8000 A1327	16	11	8000 A1914	16	18	8000 A3410	24	20	8000 A4144	13	1
8000 A0414	28	10	8000 A0877	24	16	8000 A1328	16	63	8000 A1915	16	19	8000 A3435	5	6	8000 A4146	13	1
8000 A0528	27	9	8000 A0878	24	10	8000 A1329	16	12	8000 A1916	16	20	8000 A3458	6	17	8000 A4151	4	11
8000 A0568	4	13	8000 A0879	29A	5	8000 A1330	16	13	8000 A1918	16A	15	8000 A3485	16	58	8000 A4151	4	11
8000 A0573	14	12	8000 A0882	6	12	8000 A1332	16	15	8000 A1919	16A	66	8000 A3485	16A	58	8000 A4152	4	5
8000 A0574	4	34	8000 A0893	28	6	8000 A1333	16	17	8000 A1920	16A	19	8000 A3488	16	57	8000 A4157	4	11
8000 A0575	4	35	8000 A0900	18	14	8000 A1334	16	18	8000 A1921	16A	20	8000 A3488	16A	57	8000 A4158	4	5
8000 A0611	6	5	8000 A0902	18	15	8000 A1335	16	19	8000 A2040	29A	26	8000 A3504	8	20	8000 A4159	4	5
8000 A0633	20	51	8000 A0913	24	15	8000 A1336	16	20	8000 A2042	29	20	8000 A3511	16A	1	8000 A4161	4	9
8000 A0633	20A	51	8000 A0914	24	30	8000 A1353	28	19	8000 A2043	29A	29	8000 A3512	16A	2	8000 A4162	4	36
8000 A0645	32	1	8000 A0915	24	22	8000 A1427	2	2	8000 A2044	32	33	8000 A3577	35	1	8000 A4165	5	1
8000 A0656	18	4	8000 A0917	13A	2	8000 A1427	19	60	8000 A2242	7	14	8000 A3612	24	1	8000 A4166	5	2
8000 A0663	8	28	8000 A0929	29	15	8000 A1431	14	6	8000 A2352	21	62	8000 A3612	24	13	8000 A4173	5	6
8000 A0664	32	19	8000 A0930	29	25	8000 A1507	22	5	8000 A2654	6	10	8000 A3644	22	2	8000 A4174	5	7
8000 A0669	17	24	8000 A0931	29	19	8000 A1507	22A	5	8000 A2767	8	2	8000 A3644	22A	2	8000 A4178	5	1
8000 A0670	17	25	8000 A0932	29	18	8000 A1508	22	8	8000 A2767	9	2	8000 A3648	22	12	8000 A4179	5	2
8000 A0671	17	26	8000 A0939	24	18	8000 A1508	22A	8	8000 A2785	30	18	8000 A3648	22A	12	8000 A4193	4	1
8000 A0672	29A	19	8000 A0953	33A	34	8000 A1512	1	4	8000 A2788	31	19	8000 A3649	22	13	8000 A4198	26	6
8000 A0677	2	7	8000 A0994	33	14	8000 A1559	1	3	8000 A2790	25	16	8000 A3649	22A	13	8000 A4214	26	12
8000 A0678	32	2	8000 A0995	33	15	8000 A1579	1	9	8000 A2791	25	17	8000 A3650	22	14	8000 A4219	26	10
8000 A0680	27	19	8000 A1017	15	33	8000 A1580	1	2	8000 A2792	25	30	8000 A3650	22A	14	8000 A4220	26	9
8000 A0681	18	6	8000 A1022	15	9	8000 A1589	26	3	8000 A2793	25	31	8000 A3651	22	20	8000 A4233	34	9
8000 A0693	31	29	8000 A1048	32	32	8000 A1625	1	8	8000 A2794	25	32	8000 A3651	22A	20	8000 A4233	36	9
8000 A0709	15	4	8000 A1051	33A	40	8000 A1709	30A	16	8000 A2837	24	11	8000 A3774	4	50	8000 A4234	34	8
8000 A0710	15	5	8000 A1052	33A	41	8000 A1748	16	45	8000 A2840	24	5	8000 A3970	16A	18	8000 A4234	36	8
8000 A0730	6	7	8000 A1053	33A	42	8000 A1748	16A	45	8000 A2841	24	7	8000 A3971	16A	12	8000 A4244	16	2
8000 A0731	33	28	8000 A1138	29	26	8000 A1761	26	3	8000 A2843	24	25	8000 A3972	16A	7	8000 A4245	14	1
8000 A0732	33	29	8000 A1139	29	27	8000 A1794	13A	10	8000 A2933	15	30	8000 A3975	25	24	8000 A4257	14	1
8000 A0739	15	27	8000 A1189	29A	11	8000 A1795	13A	12	8000 A2987	13	2	8000 A3975	29A	16	8000 A4265	14	1
8000 A0746	15	12	8000 A1239	28	8	8000 A1796	13A	11	8000 A3084	13A	1	8000 A4044	14	2	8000 A4266	14	1
8000 A0751	6	18	8000 A1279	15	31	8000 A1797	13A	13	8000 A3091	2	3	8000 A4045	14	3	8000 A4268	33	1



DISEGNO DRAWING DESSIN ZEICHNUNG DIBUJO	TAVOLA DRAWING TABLE BILD TABLA	INDEX NO. POS. N. INDICE	DISEGNO DRAWING DESSIN ZEICHNUNG DIBUJO	TAVOLA DRAWING TABLE BILD TABLA	INDEX NO. POS. N. INDICE	DISEGNO DRAWING DESSIN ZEICHNUNG DIBUJO	TAVOLA DRAWING TABLE BILD TABLA	INDEX NO. POS. N. INDICE	DISEGNO DRAWING DESSIN ZEICHNUNG DIBUJO	TAVOLA DRAWING TABLE BILD TABLA	INDEX NO. POS. N. INDICE	DISEGNO DRAWING DESSIN ZEICHNUNG DIBUJO	TAVOLA DRAWING TABLE BILD TABLA	INDEX NO. POS. N. INDICE	DISEGNO DRAWING DESSIN ZEICHNUNG DIBUJO	TAVOLA DRAWING TABLE BILD TABLA	INDEX NO. POS. N. INDICE
8000 A4271	33	1	8000 A4607	26	30	8000 A5309	4	1	8000 A5592	7	5	8000 A5662	9	12	8000 A5947	20	49
8000 A4275	27	1	8000 A4609	26	25	8000 A5364	22	20	8000 A5595	7	5	8000 A5671	8	1	8000 A5959	20A	49
8000 A4288	31	14	8000 A4610	26	31	8000 A5364	22A	20	8000 A5603	8	1	8000 A5671	9	1	8000 A5960	20A	50
8000 A4291	25	15	8000 A4630	24	9	8000 A5396	3	5	8000 A5603	9	1	8000 A5703	5	2	8000 A5961	20A	1
8000 A4295	2	3	8000 A4631	4	8	8000 A5413	3	16	8000 A5616		6	8000 A5705	24	27	8000 A5963	20A	4
8000 A4295	13	20	8000 A4721	34	3	8000 A5414	3	16	8000 A5617	13	8	8000 A5721	16	1	8000 A5981	3	14
8000 A4296	2	3	8000 A4721	36	3	8000 A5415	3	16	8000 A5618	13	18	8000 A5723	16	11	8000 A5982	3	14
8000 A4296	13	20	8000 A4722	35	3	8000 A5416	3	16	8000 A5619	13	19	8000 A5724	16	15	8000 A5992	29	11
8000 A4305	26	24	8000 A4722	37	3	8000 A5417	3	16	8000 A5620	13	21	8000 A5725	16	12	8000 A6010	20A	4
8000 A4306	26	1	8000 A4789	17	4	8000 A5418	3	16	8000 A5621	13	22	8000 A5735	3	15	8000 A6012	20A	50
8000 A4326	37	2	8000 A4790	7	1	8000 A5419	3	16	8000 A5622	13	24	8000 A5736	3	15	8000 A6013	20A	49
8000 A4349	1	16	8000 A4791	7	1	8000 A5420	3	16	8000 A5623	13	25	8000 A5737	4	37	8000 A6041	22A	1
8000 A4394	25	35	8000 A4841	34	7	8000 A5421	3	16	8000 A5624	13	26	8000 A5740	13	1	8000 A6043	20A	49
8000 A4395	19	15	8000 A4841	35	7	8000 A5425	6	18	8000 A5625	13	37	8000 A5741	13	1	8000 A6044	20A	50
8000 A4404	21	1	8000 A4841	36	7	8000 A5435	4	16	8000 A5626	13	38	8000 A5755	3	14	8000 A6050	3	1
8000 A4409	22	1	8000 A4841	37	7	8000 A5436	4	15	8000 A5627	13	39	8000 A5773	1	6	8000 A6051	20A	51
8000 A4410	22	1	8000 A4842	34	6	8000 A5437	4	15	8000 A5628	13	40	8000 A5783	4	37	8000 A6052	3	3
8000 A4413	22	1	8000 A4842	35	6	8000 A5438	4	9	8000 A5629	13	42	8000 A5879	20A	58	8000 A6068	20	64
8000 A4427	23	8	8000 A4842	36	6	8000 A5439	4	8	8000 A5630	13	43	8000 A5889	15	17	8000 A6069	20	58
8000 A4428	23	4	8000 A4842	37	6	8000 A5440	4	8	8000 A5631	13	44	8000 A5890	15	6	8000 A6076	29A	1
8000 A4429	23	1	8000 A4844	27	24	8000 A5441	4	9	8000 A5632	13	45	8000 A5891	15	51	8000 A6078	29A	25
8000 A4430	23	14	8000 A4845	27	25	8000 A5442	4	9	8000 A5633	13	46	8000 A5892	15	35	8000 A6088	15	34
8000 A4431	23	11	8000 A4859	31	16	8000 A5443	4	9	8000 A5634	13	51	8000 A5894	15	37	8000 A6110	3	3
8000 A4457	24	24	8000 A4875	26	38	8000 A5444	4	8	8000 A5635	13	52	8000 A5895	15	14	8000 A6115	2	3
8000 A4495	29	1	8000 A4877	17	39	8000 A5445	4	8	8000 A5636	13	55	8000 A5900	15	15	8000 A6115	13	20
8000 A4511	16	52	8000 A4915	37	1	8000 A5456	3	1	8000 A5637	13	83	8000 A5901	15	39	8000 A6121	28	7
8000 A4511	16A	52	8000 A4953	7	8	8000 A5459	3	4	8000 A5638	13	85	8000 A5906	10	5	8000 A6122	28	7
8000 A4547	2	4	8000 A5065	22	2	8000 A5460	3	5	8000 A5639	13	90	8000 A5910	1	17	8000 A6125	28	2
8000 A4552	29	1	8000 A5067	22	3	8000 A5462	3	9	8000 A5640	13	96	8000 A5911	1	18	8000 A6126	28	1
8000 A4562	27	4	8000 A5067	22A	3	8000 A5466	3	1	8000 A5641	13	122	8000 A5912	1	20	8000 A6127	28	4
8000 A4563	27	3	8000 A5068	22	3	8000 A5467	3	3	8000 A5642	13	123	8000 A5918	2	3	8000 A6128	28	4
8000 A4564	29	2	8000 A5068	22A	3	8000 A5470	3	1	8000 A5643	13	148	8000 A5918	13	20	8000 A6129	28	2
8000 A4565	29	3	8000 A5069	22A	3	8000 A5471	3	3	8000 A5644	13	152	8000 A5920	33A	1	8000 A6130	28	1
8000 A4566	29	9	8000 A5070	22	3	8000 A5474	3	4	8000 A5645	13	206	8000 A5921	6	17	8000 A6131	28	4
8000 A4568	29	3	8000 A5070	22A	3	8000 A5475	3	5	8000 A5646	13	207	8000 A5923	3	6	8000 A6132	28	7
8000 A4569	29	9	8000 A5071	22	7	8000 A5476	3	6	8000 A5647	13	209	8000 A5924	38	24	8000 A6136	28	7
8000 A4570	29	39	8000 A5071	22A	7	8000 A5479	3	1	8000 A5648	13	241	8000 A5925	38	27	8000 A6137	28	4
8000 A4573	15	42	8000 A5072	22	10	8000 A5480	3	3	8000 A5649	13	243	8000 A5926	2	11	8000 A6138	28	7
8000 A4574	15	43	8000 A5072	22A	10	8000 A5483	3	1	8000 A5650	13	244	8000 A5927	38	11	8000 A6139	28	7
8000 A4592	16A	1	8000 A5074	22	13	8000 A5484	3	3	8000 A5651	13	245	8000 A5928	38	13	8000 A6179	20	41
8000 A4605	2	8	8000 A5074	22A	13	8000 A5506	24	1	8000 A5652	13	264	8000 A5929	38	6	8000 A6186	5	1
8000 A4606	29	39	8000 A5308	4	1	8000 A5567	33A	35	8000 A5653	13	265	8000 A5946	20	50	8000 A6211	2	9



DISEGNO DRAWING DESSIN ZEICHNUNG DIBUJO	TAVOLA DRAWING TABLE BILD TABLA	INDEX NO. POS. N. INDICE	DISEGNO DRAWING DESSIN ZEICHNUNG DIBUJO	TAVOLA DRAWING TABLE BILD TABLA	INDEX NO. POS. N. INDICE	DISEGNO DRAWING DESSIN ZEICHNUNG DIBUJO	TAVOLA DRAWING TABLE BILD TABLA	INDEX NO. POS. N. INDICE	DISEGNO DRAWING DESSIN ZEICHNUNG DIBUJO	TAVOLA DRAWING TABLE BILD TABLA	INDEX NO. POS. N. INDICE	DISEGNO DRAWING DESSIN ZEICHNUNG DIBUJO	TAVOLA DRAWING TABLE BILD TABLA	INDEX NO. POS. N. INDICE	DISEGNO DRAWING DESSIN ZEICHNUNG DIBUJO	TAVOLA DRAWING TABLE BILD TABLA	INDEX NO. POS. N. INDICE
8000 A6240	28	3	80A0 69551	22	22	80C0 A1761	26	3	8A00 55241	9	19	8A00 87810	21	10	8A00 A0939	24	18
8000 A6241	28	3	80A0 69551	22A	22	80C0 A4200	26	12	8A00 55241	15	38	8A00 88873	33A	26	8A00 A1706	29A	20
8000 A6242	29	8	80A0 73456	21	15	80C0 A4214	26	12	8A00 55241	25	11	8A00 90662	1	5	8A00 A1800	13A	22
8000 A6271	7	2	80A0 74388	21	22	80C0 A4219	26	10	8A00 55241	30	17	8A00 91582	4	16	8A00 A1806	13A	8
8000 A6281	35	9	80A0 89953	19	9	80C0 A4220	26	9	8A00 55860	31	5	8A00 91975	14	2	8A00 A1807	13A	14
8000 A6281	37	9	80A0 89962	19	10	80D0 A4235	27	23	8A00 58929	31	5	8A00 92876	30A	17	8A00 A1809	13A	9
8000 A6282	35	8	80A0 91548	4	22	80D0 A4236	27	22	8A00 58930	31	5	8A00 92986	30	15	8A00 A2044	32	34
8000 A6282	37	8	80A0 91551	10	16	80G0 69337	20	66	8A00 59433	19	38	8A00 92986	30A	15	8A00 A3485	16	58
8000 A6283	35	5	80A0 91792	18	1	80G0 69338	20	67	8A00 59434	19	40	8A00 93011	32	31	8A00 A3485	16A	58
8000 A6283	37	5	80A0 99174	11	1	8661 0191A	26	34	8A00 60415	17	1	8A00 93124	23	13	8A00 A3801	6	1
8000 A6284	35	4	80A0 99774	32	9	8A00 01261	12	18	8A00 61261	16A	9	8A00 93324	23	10	8A00 A4092	20A	64
8000 A6284	37	4	80A0 99836	4	22	8A00 01815	19	13	8A00 62733	29	13	8A00 94119	33A	28	8A00 A4162	4	36
8000 A6294	30	16	80A0 A0264	19	52	8A00 06911	33	11	8A00 62797	22	30	8A00 94120	33A	32	8A00 A4288	31	14
8000 A6304	6	18	80A0 A0675	19	46	8A00 06911	33A	11	8A00 62797	22A	30	8A00 94754	30A	8	8A00 A4305	26	24
8000 A6305	6	17	80A0 A0676	19	44	8A00 15960	3	8	8A00 65503	20	56	8A00 95276	18	16	8A00 A4306	26	1
8000 A6443	8	1	80A0 A1054	11	1	8A00 15960	10	11	8A00 65503	20A	56	8A00 96643	20A	5	8A00 A4859	31	16
8000 A6443	9	1	80A0 A3506	10	13	8A00 18246	33A	29	8A00 65847	8	12	8A00 96811	20	1	8A00 A5308	4	1
8000 A6445	8	1	80A0 A4206	26	16	8A00 19768	8	8	8A00 66661	19	8	8A00 96837	31	16	8A00 A5309	4	1
8000 A6445	9	1	80A0 A4216	26	2	8A00 19768	9	9	8A00 66661	19	17	8A00 96930	30	21	8A00 A5435	4	16
8000 A6468	13	9	80A0 A5905	10	1	8A00 20373	33A	33	8A00 66661	21	34	8A00 96930	30A	21	8A00 A5462	3	9
8000 A6469	9	20	80A0 A5931	10	13	8A00 26846	31	20	8A00 66661	25	8	8A00 96937	31	8	8A00 A5617	13	7
8000 A6470	15	18	80A0 A5934	10	13	8A00 28183	5	9	8A00 67207	19	61	8A00 97015	20	49	8A00 A5634	13	51
8000 A6477	33	6	80A0 A5989	20A	66	8A00 28553	10	17	8A00 67545	10	8	8A00 97016	20	50	8A00 A5773	1	6
8000 A6484	33A	43	80A0 A5990	20A	67	8A00 28855	10	3	8A00 67545	11	3	8A00 97593	31	8	8A00 A5879	20A	58
8000 A6485	28	3	80A0 A6283	34	5	8A00 37283	26	41	8A00 67997	14	9	8A00 97739	16	28	8A00 A5929	38	7
8000 A6486	28	3	80A0 A6283	36	5	8A00 37947	18	11	8A00 67997	20	52	8A00 97739	16A	28	8A00 A5961	20A	1
8000 A6487	2	10	80A0 A6284	34	4	8A00 38350	6	2	8A00 67997	20A	52	8A00 98186	13	27	8A00 A6010	20A	4
8000 A6488	2	10	80A0 A6284	36	4	8A00 41459	33	10	8A00 67997	21	23	8A00 98275	13	29	8A00 A6229	29A	10
8000 A6635	33A	38	80A0 A6630	20A	67	8A00 41459	33A	10	8A00 69282	21	26	8A00 99475	17	29	8A00 A6635	33A	39
8000 A6638	32	28	80A0 A6631	20A	66	8A00 42100	9	6	8A00 69315	20	57	8A00 99660	17	23	8A00 A6642	32	31
8000 A6641	20A	7	80B0 A1589	26	3	8A00 42700	16	53	8A00 69315	20A	57	8A00 99708	17	12	8AA0 73909	21	16
8000 A6642	32	30	80B0 A3196	35	2	8A00 42700	16A	53	8A00 71091	19	22	8A00 99840	3	9	8AA0 99587	19	1
8000 A6644	26	30	80B0 A4206	26	16	8A00 47773	5	8	8A00 74716	12	27	8A00 A0085	31	6	8B00 07989	15	41
8000 A6683	20	74	80B0 A4235	27	23	8A00 47773	12	3	8A00 76026	25	9	8A00 A0129	14	13	8B00 26846	31	10
8000 A6746	20	74	80B0 A4236	27	22	8A00 48127	16A	32	8A00 80171	13A	6	8A00 A0232	4	33	8B00 35794	7	4
8000 A7143	29	17	80B0 A5989	20A	66	8A00 53504	30	6	8A00 84473	15	29	8A00 A0303	4	48	8B00 36023	16A	10
8000 A7144	29	21	80B0 A5990	20A	67	8A00 55241	8	4	8A00 85071	4	3	8A00 A0611	6	5	8B00 43715	17	16
8000 A7145	29	38	80B0 A6630	20A	67	8A00 55241	8	4	8A00 86138	23	19	8A00 A0677	19	37	8B00 55241	9	7
8000 A7271	38	1	80B0 A6631	20A	66	8A00 55241	8	27	8A00 86938	31	9	8A00 A0693	31	29	8B00 57196	5	3
80A0 42349	27	16	80C0 55699	27	26	8A00 55241	8	29	8A00 86980	16A	31	8A00 A0872	17	34	8B00 57196	5	4
80A0 52662	29A	2	80C0 69337	20	66	8A00 55241	9	4	8A00 87717	20	3	8A00 A0873	28	20	8B00 65442	31	27
80A0 65535	26	8	80C0 69338	20	67	8A00 55241	9	4	8A00 87717	20A	3	8A00 A0902	18	15	8B00 66525	20	71

DISEGNO DRAWING DESSIN ZEICHNUNG DIBUJO	TAVOLA DRAWING TABLE BILD TABLA	INDEX NO. POS. N. INDICE	DISEGNO DRAWING DESSIN ZEICHNUNG DIBUJO	TAVOLA DRAWING TABLE BILD TABLA	INDEX NO. POS. N. INDICE	DISEGNO DRAWING DESSIN ZEICHNUNG DIBUJO	TAVOLA DRAWING TABLE BILD TABLA	INDEX NO. POS. N. INDICE	DISEGNO DRAWING DESSIN ZEICHNUNG DIBUJO	TAVOLA DRAWING TABLE BILD TABLA	INDEX NO. POS. N. INDICE	DISEGNO DRAWING DESSIN ZEICHNUNG DIBUJO	TAVOLA DRAWING TABLE BILD TABLA	INDEX NO. POS. N. INDICE	DISEGNO DRAWING DESSIN ZEICHNUNG DIBUJO	TAVOLA DRAWING TABLE BILD TABLA	INDEX NO. POS. N. INDICE
8B00 66525	20A	71	8C00 68934	24	21	8EA0 99587	19	1	8S00 67545	10	10						
8B00 66953	9	14	8C00 69056	20	65	8F00 28183	5	5	8S00 82751	29A	31						
8B00 67545	27	7	8C00 69056	20A	65	8F00 35794	7	4	8S00 A4162	4	36						
8B00 67545	28	15	8C00 69429	26	21	8F00 67545	10	9	8SA0 67545	33	17						
8B00 67997	20	71	8C00 80171	13A	6	8F00 79785	31	27	8SA0 67545	33A	17						
8B00 68934	24	21	8C00 81650	8	25	8F00 95276	38	10	8T00 68873	27	12						
8B00 69056	19	14	8C00 81650	9	17	8F00 A4162	4	36	8T00 80171	13A	6						
8B00 69056	19	65	8C00 95276	38	4	8F00 A4624	13	28	8T00 A4162	4	36						
8B00 73893	25	23	8C00 96746	6	1	8F00 A5927	38	8	8U00 A4162	4	36						
8B00 79783	31	27	8C00 96837	31	16	8G00 07989	16	22	8V00 A4162	4	36						
8B00 79785	31	27	8C00 98196	13	23	8G00 07989	16	23	8W00 A4162	4	36						
8B00 81650	8	25	8C00 A2836	24	4	8G00 07989	16A	22									
8B00 81650	9	17	8C00 A4162	4	36	8G00 10904	15	10									
8B00 82879	30A	3	8C00 A5435	4	16	8G00 32069	16A	23									
8B00 82879	31	3	8C00 A5927	38	14	8G00 66179	29A	13									
8B00 91582	4	16	8D00 26846	31	10	8G00 73458	19	27									
8B00 95276	38	9	8D00 28183	5	9	8G00 73458	19	28									
8B00 96837	31	16	8D00 36022	16	5	8G00 79783	31	27									
8B00 96838	30A	10	8D00 36022	16A	5	8G00 96837	31	16									
8B00 96932	30	18	8D00 43716	17	18	8G00 99475	4	50									
8B00 96932	30A	18	8D00 62797	23	17	8G00 99840	3	9									
8B00 99475	17	13	8D00 67997	17	40	8G00 A1804	13A	7									
8B00 99475	17	30	8D00 80171	13A	6	8G00 A4162	4	36									
8B00 A0226	2	1	8D00 81650	8	25	8G00 A5927	38	15									
8B00 A0702	27	8	8D00 81650	9	17	8H00 28183	5	9									
8B00 A1806	13A	8	8D00 94010	27	20	8H00 A1804	13A	7									
8B00 A2785	30	18	8D00 96837	31	16	8H00 A4162	4	36									
8B00 A2836	24	4	8D00 98186	13	27	8H00 A4195	3	9									
8B00 A3509	6	12	8D00 99840	3	9	8J00 A4162	4	36									
8B00 A4162	4	36	8D00 A4162	4	36	8K00 A1804	13A	7									
8B00 A4195	3	9	8D00 A4624	13	28	8K00 A4162	4	36									
8B00 A4306	26	1	8D00 A5927	38	17	8L00 66179	25	20									
8B00 A4859	31	16	8E00 30053	6	20	8L00 A4162	4	36									
8B00 A5435	4	16	8E00 34292	12	14	8M00 70379	28	9									
8B00 A5462	3	9	8E00 67545	3	17	8M00 A4162	4	36									
8B00 A5961	20A	1	8E00 67997	26	27	8M00 A5928	38	5									
8C00 26846	31	20	8E00 80171	13A	6	8N00 A4162	4	36									
8C00 28183	5	9	8E00 95276	38	12	8N00 A5928	38	19									
8C00 35794	7	4	8E00 99475	18	12	8P00 A4162	4	36									
8C00 56768	31	27	8E00 A4162	4	36	8R00 99587	19	1									
8C00 61121	21	20	8E00 A4195	3	9	8R00 A4162	4	36									
8C00 63811	7	3	8E00 A5928	38	3	8S00 67545	3	7									