



**INFORMAZIONI GENERALI**

Il presente catalogo serve per richiedere con esattezza le parti di ricambio  
 Nelle ordinazioni indicare:

- 1) il numero di codice dei particolari seguito dalla descrizione;
  - 2) il colore per i pezzi verniciati o comunque colorati;
  - 3) il numero di matricola del motociclo, stampigliato sul canotto di sterzo.
- Le indicazioni destra e sinistra si riferiscono ai lati del veicolo rispetto al senso di marcia;

**GENERAL INFORMATION**

The present spare parts list enables one to order exactly the right spare parts.

When ordering specify:

- 1) the part's code number followed by its description;
  - 2) indicate colour for painted or coloured parts;
  - 3) the motorcycle's serial number, stamped on the steering head.
- References to right and left apply to the vehicle in terms of its direction of movement.

**INFORMATIONS GENERALES**

Ca catalogue permet de commander correctement les pièces de rechange.

Les commandes doivent être passées en indiquant:

- 1) le numéro de code des pièces détachées suivi de leur description;
  - 2) le couleur des pièces peintes ou colorés;
  - 3) le matricule de la moto, estampillé sur la tige du guidon.
- Droite et gauche sont les côtés du véhicule par rapport au sens de la marche.

**ALLGEMEINE HINWEISE**

Dieser Ersatzteilkatalog dient zur genauen Angabe der Teile bei Ersatzteilbestellungen.

Bei Ersatzbestellung ist folgendes anzugeben:

- 1) Die Bestellnummer der Ersatzteile mit der entsprechenden Beschreibung;
  - 2) Farbe für lackierte und farbige Teile angeben;
  - 3) Die Sseriennummer des Motorrads, die am Lenkrohr eingepägt ist.
- Die Angaben rechts und links beziehen sich auf das Fahrzeug in Fahrrihtung.

**INFORMACIONES GENERALES**

El presente catálogo sirve para pedir con exactitud las partes de recambio.  
 En los pedidos se debe indicar:

- 1) el número de código de la parte y a continuación la descripción;
- 2) el color para las piezas barnizadas o coloreadas;
- 3) el número de matrícula de la motocicleta, estampado en le tubo de dirección. Las indicaciones derecha e izquierda se refieren a los lados del vehículo respecto del sentido de marcha.

**NOTE - LIST - NOTES - NOTE - NOTAS:**

- A** : In alternativa - In alternative - En alternative - Wahlweise - En alternativa  
**B** : Modello **TE 310** - **TE 310** model - Modéle **TE 310** - Modell **TE 310** - Modélo **TE 310**  
**C** : Modello **TC 250** - **TC 250** model - Modéle **TC 250** - Modell **TC 250** - Modélo **TC 250**  
**D** : In dotazione - To issue - En necessaire - Ausrüstungsteile - En dotaciòn  
**E** : Ad esaurimento - To fell out - A' finir - Erschöpfung - A agotamiento  
**F** : Fornire assieme - Supply unitedly - Fournir ensemble - Wird zusammen geliefert Equipar juntos  
**G** : Solo per AUS - Only for AUS. - Soulement pour AUS  
 Nur für AUS- Solo por AUS  
**J** : Solo per Giappone - Only for Japan - Soulement pour Japon - Nur für Japan  
 Solo por Japòn  
**K** : Modello **TXC 310** - **TXC 310** model - Modéle **TXC 310** - Modell **TXC 310** - Modélo **TXC 310**  
**H** : Potenziamento per uso sportivo su circuito di gara - Powering for racing use on circuit - Augmentation de la puissance pour usage sportif sur piste - Potenzierung für wettkämpferischen Gebrauch des Motorrad - Aumento de la potencia para uso agonístico sobre circuito de competición  
**N** : Non fornito - Not supplied - Ne pas fournir - Keine Gelieferende - No equiparado  
**Ø** : Non per JPN - Not for JPN - Ne pas pour JPN - Keine für JPN - No por JPN  
**P** : Non per SMR - Not for SMR - Ne pas pour SMR - Keine für SMR - No por SMR  
**R** : A richiesta - Upon request - Sur demande - Auf anfrage - a pedimento  
**S** : Di serie - Supplied - De série - Standard - De serie  
**T** : Modello **TXC 250** - **TXC 250** model - Modéle **TXC 250** - Modell **TXC 250** - Modélo **TXC 250**  
**U** : Solo per U.S.A. - Only for U.S.A. - Soulement pour U.S.A.  
 Nur für U.S.A. - Solo por U.S.A.  
**X** : Non per U.S.A. - Not for U.S.A. - Ne pas pour U.S.A. - Keine für U.S.A - No por U.S.A.  
**XB** : Non per BR - Not for BR - Ne pas pour BR - Keine für BR - No por BR  
**Y** : Non per TC - Not for TC - Ne pas pour TC - Keine für TC - No por TC  
**W** : Modello **TE 250** - **TE 250** model - Modéle **TE 250** - Modell **TE 250** - Modélo **TE 250**  
**Z** : n° denti, number of teeth, numéro dents, Zähne nummer - número dientes

- A** : Austria, Austria, Autriche, Österreich, Austria  
**AUS** : Australia, Australia, Australie, Australien, Australia  
**BR** : Brasile, Brazil, Brésil, Brasilien, Brasil  
**CDN** : Canada, Canada, Canada, Kanada, Canadá  
**CH** : Svizzera, Switzerland, Suisse, Schweizer, Suiza  
**D** : Germania, Germany, Allemagne, Deutschland, Alemania  
**E** : Spagna, Spain, Espagne, Spanien, España  
**F** : Francia, France, France, Frankreich, Francia  
**GB** : Gran Bretagna, Great Britain, Grand Bretagne, Groos Britan, Gran Bretaña  
**I** : Italia, Italy, Italie, Italien, Italia  
**J** : Giappone, Japan, Japon, Japan, Japòn  
**SF** : Finlandia, Finald, Finlande, Finnland, Finlandia  
**USA** : Stati Uniti d'America, United States of America, Etats Units d'Amérique, Vereinigte Staaten von Amerika, Estados Unidos

Dati indicativi soggetti a modifiche senza impegno di preavviso.  
 All data are subject to modification without prior notice.  
 Données indicatif sujet au modifications sans obligation de préavis.  
 Änderungen Vorbehalten.  
 Datos indicativos sujetos a modificaciones sin compromiso de preaviso.

N° DI MATRICOLA INIZIALE - INITIAL SERIAL NUMBER - MATRICULE INITIAL - BEGINNTESERIENNUMMER - MATRICULA INICIAL	
MODELLO - MODEL MODELE - MODELL MODELO	MATRICOLA - SERIAL NUMBER MATRICULE - SERIENNUMMER MATRICULA
<b>TC 250</b>	<b>ZKHA300AADV050000</b>
<b>TC 250/USA</b>	<b>ZKHTC253#DV000000</b>
<b>TE 250</b>	<b>ZKHA300AADV000000</b>
<b>TXC 250</b>	<b>ZKHTX250#DV000000</b>
<b>TE 310</b>	<b>ZKHA301AADV000000</b>
<b>TE 310/USA</b>	<b>ZKHKCEDG#DV000000</b>
<b>TXC 310</b>	<b>ZKHTX313#DV000000</b>

Tavola Drawing Table Bild Tabla	Denominazione	Description	Designation	Bezeichnung	Denominacion	Pagina Page Page Seite Paja
1	ATTREZZI DI ASSISTENZA, MANUALI E CATALOGHI	SERVICE TOOLS, MANUALS AND CATALOGS	OUTILS D'ASSISTANCE, MANUELS ET CATALOGUES	HILFAUSRUSTUNG, HANDBUCH UND KATALOG	HERRAMIENTAS DE ASISTENCIA, MANUALESY CATALOGOS	17
2	CILINDRO, PISTONE	CYLINDER, PISTON	CYLINDRE, PISTON	ZYLINDER, KOLBEN	CILINDRO, PISTON	19
3	TESTA CILINDRO	CYLINDER HEAD	CULASSE	ZYLINDERKOPF	CULATA	21
4	MANOVELLISMO	CRANKSHAFT	VILEBREQUIN	KURBELWELLE	CIGÜEÑAL	25
5	TRASMISSIONE PRIMARIA, FRIZIONE	PRIMARY DRIVE, CLUTCH	TRANSMISSION PRIMAIRE, EMBRAYAGE	PRIMÄRÜBERSETZUNG, KUPPLUNG	TRANSMISION PRIMARIA, EMBRAGUE	27
6	DISTRIBUZIONE	VALVE TIMING	DISTRIBUTION	VENTILSTEUERUNG	DISTRIBUCION	29
7	SEMICARTER SINISTRO	L.H. HALF CRANKCASE	CARTER G.	GEHAUSEDECKEL L.	BANCADA IZQ.	31
8	SEMICARTER DESTRO	R.H. HALF CRANKCASE	CARTER D.	GEHAUSEDECKEL R.	BANCADA DER.	33
9	COPERCHI SEMICARTER DX	R.H. HALF CRANKCASE COVERS	COUVERCLES CARTER D.	GEHAUSEDECKEL R.	TAPAS BANCADA DER.	35
10	COPERCHI SEMICARTER SX	L.H. HALF CRANKCASE COVERS	COUVERCLES CARTER G.	GEHAUSEDECKEL L.	TAPAS BANCADA IZQ.	37
11	LUBRIFICAZIONE	OIL PUMP	PUMPE HUILE	MOTORSCHMIERUNG	LUBRICACION	39
12	PARTE ELETTRICA, IMPIANTO ELETTRICO	IGNITION SISTEM, ELECTRIC SYSTEM	PARTIES ELECTRIQUE, INSTALLATION ELECTRIQUE	ELEKTRISCHE TEILE, ELEKTRISHE ANLAGE	PARTE ELECTRICA, INSTALLACION ELECTRICA	41
13	AVVIAMENTO A PEDALE	KICK STARTER	DEMARRAGE Á PÈDALE	KICK ANLASSER	ARRANQUE A PEDAL	43
13A	AVVIAMENTO ELETTRICO E A PEDALE	ELECTRIC STARTING AND KICK STARTER	DEMARRAGE ELECTRIQUE ET Á PÈDALE	ELEKTRISCHE ANLASSER UND KICK ANLASSER	ARRANQUE ELECTRICO Y A PEDAL	45
14	COMANDO CAMBIO (TC)	GEARSHIFT MECHANISM (TC)	COMMANDE DE VITESSE (TC)	GANGSCHALTUNG (TC)	MANDO CAMBIO (TC)	49
14A	COMANDO CAMBIO (TE-TXC)	GEARSHIFT MECHANISM (TE-TXC)	COMMANDE DE VITESSE (TE-TXC)	GANGSCHALTUNG (TE-TXC)	MANDO CAMBIO (TE-TXC)	51
15	CAMBIO VELOCITA' (TC)	GEARBOX (TC)	BOITE VITESSES (TC)	ZAHNRADGETRIEBE (TC)	CAJA CAMBIO (TC)	53
15A	CAMBIO VELOCITA' (TE-TXC)	GEARBOX (TE-TXC)	BOITE VITESSES (TE-TXC)	ZAHNRADGETRIEBE (TE-TXC)	CAJA CAMBIO (TE-TXC)	55
16	CORPO FARFALLATO	THROTTLE BODY	CORP PAPIILLON	DROSSELKLAPPENKÖRPER	CUERPO OSCILANTE	57
17	POMPA ACQUA	WATER PUMP	POMPE EAU	WASSERPUMPE	BOMBA AGUA	59
18	IMPIANTO DI RAFFREDAMENTO (TC)	COOLING SYSTEM (TC)	INSTALLATION RAFROIDISSEMENT (TC)	SCHMIERUNGSSYSTEM (TC)	EQUIPO DE ENFRIAMIENTO (TC)	61
18A	IMPIANTO DI RAFFREDAMENTO (TE-TXC)	COOLING SYSTEM (TE-TXC)	INSTALLATION RAFROIDISSEMENT (TE-TXC)	SCHMIERUNGSSYSTEM (TE-TXC)	EQUIPO DE ENFRIAMIENTO (TE-TXC)	63
19	ASPIRAZIONE E FILTRO ARIA (TE-TXC)	AIR BOX AND FILTER (TE-TXC)	ASPIRATION ET FILTRE AIRE (TE-TXC)	ANSAUGEN UND LUFTFILTER (TE-TXC)	ASPIRATION Y FILTRO DE AIRE (TE-TXC)	65
19A	ASPIRAZIONE E FILTRO ARIA (TC250)	AIR BOX AND FILTER (TC250)	ASPIRATION ET FILTRE AIRE (TC250)	ANSAUGEN UND LUFTFILTER (TC250)	ASPIRATION Y FILTRO DE AIRE (TC250)	67
19B	BLOW-BY (TE-TXC-TC250)	BLOW-BY (TE-TXC-TC250)	BLOW-BY (TE-TXC-TC250)	BLOW-BY (TE-TXC-TC250)	BLOW-BY (TE-TXC-TC250)	69
19C	BLOW-BY (TE-TXC310)	BLOW-BY (TE-TXC310)	BLOW-BY (TE-TXC310)	BLOW-BY (TE-TXC310)	BLOW-BY (TE-TXC310)	71
20	TELAIO, PEDANE	FRAME, FOOT RESTS	CADRE, REPOSE PIEDS	RAHMEN, FUSSBRETT	BASTIDOR, REPOSAPIES	73
21	SOSPENSIONE ANTERIORE (TE)	FRONT FORK ASSEMBLY (TE)	SUSPENSION AVANT (TE)	VORDERTELESKOPGABEL (TE)	SUSPENSION DELANTERA (TE)	77
21A	SOSPENSIONE ANTERIORE (TC-TXC)	FRONT FORK ASSEMBLY (TC-TXC)	SUSPENSION AVANT (TC-TXC)	VORDERTELESKOPGABEL (TC-TXC)	SUSPENSION DELANTERA (TC-TXC)	81
22	FORCELLONE POSTERIORE	REAR SWING ARM	FOURCHE ARRIERE	HINTERGABEL	HORQUILLA TRASERA	85

Tavola Drawing Table Bild Tabla	Denominazione	Description	Designation	Bezeichnung	Denominacion	Pagina Page Seite Paja
23	AMMORTIZZATORE POSTERIORE (TC-TXC)	REAR SUSPENSION (TC-TXC)	SUSPENSION ARRIERE (TC-TXC)	HINTERHAUFHANGUNG (TC-TXC)	SUSPENSION TRASERA (TC-TXC)	89
23A	AMMORTIZZATORE POST. (TE)	REAR SUSPENSION (TE)	SUSPENSION ARRIERE (TE)	HINTERHAUFHANGUNG (TE)	SUSPENSION TRASERA (TE)	91
24	LEVRAGGI SOSPENSIONI POSTERIORE	REAR SUSPENSION LINKAGE	LEVIER SUSPENSION ARRIERE	HEBELWERK HINTERHAUFHANGUNG	PALANCA SUSPENSION TRASERA	93
25	MANUBRIO E COMANDI	HANDLEBAR AND CONTROLS	GUIDON ET COMMANDES	LENKER UND STEUERORGANE	MANILLAR Y MANDOS	95
26	FRENO IDRAULICO POSTERIORE	REAR HYDRAULIC BRAKE	FREIN HYDRAULIQUE ARRIERE	HINTERBREMSE	FRENO HIDRAULICO TRASERO	97
27	PANNELLI, PARAFANGHI, SELLA	PANEL, FENDERS, SEAT,	PANNEAU, GARDE-BOUES, SIEGE,	STREIFEN, KOTFLUGEL, SATTEL	PANELO, GUARDABARROS, SILLIN	101
28	SERBATOIO CARBURANTE, CONVOGIATORI (TC)	GAS TANK, PANEL (TC)	RESERVOIR CARBURANT, FLANC (TC)	KRAFTSTOFFBEHALTER, FLANKE (TC)	DEPOSITO GASOLINA, LATERAL (TC)	105
28A	SERBATOIO CARBURANTE, CONVOGIATORI (TE-TXC)	GAS TANK, PANEL (TE-TXC)	RESERVOIR CARBURANT, FLANC (TE-TXC)	KRAFTSTOFFBEHALTER, FLANKE (TE-TXC)	DEPOSITO GASOLINA, LATERAL (TE-TXC)	107
29	SCARICO (TE-TXC)	EXHAUST SYSTEM (TE-TXC)	TUYAU D'ECHAPPEMENT (TE-TXC)	AUSPUFFROHR (TE-TXC)	TUBO DE ESCAPE (TE-TXC)	111
29A	SCARICO (TC)	EXHAUST SYSTEM (TC)	TUYAU D'ECHAPPEMENT (TC)	AUSPUFFROHR (TC)	TUBO DE ESCAPE (TC)	113
30	FRENO IDRAULICO ANTERIORE	FRONT HYDRAULIC BRAKE	FREIN HYDRAULIQUE AVANT	VORDERBREMSE	FRENO HIDRAULICO DELANTERO	115
31	RUOTA ANTERIORE	FRONT WHEEL	ROUE AV.	VORTERRAD	RUEDA DELANTERA	117
32	RUOTA POSTERIORE	REAR WHEEL	ROUE ARRIERE	HINTERRAD	RUEDA TRASERA	119
33	STRUMENTO DIGITALE, INDICATORI DI DIREZIONE, AVVISATORE ACUSTICO	DIGITAL INSTRUMENT, BLINKERS, HORN	INSTRUMENT DIGITAL, CLIGNOTANTS, SIGNALATEUR ACOUSTIQUE	DIGITAL TACHOMETER, BLINKERS, HUPE	INSTRUMENTO DIGITAL, INTERMITENTES, AVISADOR ACUSTICO	123
33A	PARTE ELETTRICA, IMPIANTO ELETTRICO	IGNITION SYSTEM, ELECTRIC SYSTEM	PARTIES ELECTRIQUE, INSTALLATION ELECTRIQUE	ELEKTRISCHE TEILE, ELEKTRISCHE ANLAGE	PARTE ELECTRICA, INSTALLACION ELECTRICA	127
34	GRUPPO CAVI, PARTI ELETTRICHE (TE)	MAIN WIRING HARNESS, ELECTRICAL PARTS (TE)	CABLES PRINCIPAL, PARTIES ELECTRIQUES (TE)	KABEL, ELEKTRISCHE KOMPONENTE (TE)	GRUPO PRINCIPAL CABLES, PARTES ELECTRICAS (TE)	129
34A	GRUPPO CAVI, PARTI ELETTRICHE (TXC)	MAIN WIRING HARNESS, ELECTRICAL PARTS (TXC)	CABLES PRINCIPAL, PARTIES ELECTRIQUES (TXC)	KABEL, ELEKTRISCHE KOMPONENTE (TXC)	GRUPO PRINCIPAL CABLES, PARTES ELECTRICAS (TXC)	133
34B	PARTE ELETTRICA, IMPIANTO ELETTRICO	IGNITION SYSTEM, ELECTRIC SYSTEM	PARTIES ELECTRIQUE, INSTALLATION ELECTRIQUE	ELEKTRISCHE TEILE, ELEKTRISCHE ANLAGE	PARTE ELECTRICA, INSTALLACION ELECTRICA	135
35	DECALCOMANIE (TC250)	TRANSFER (TC250)	DECALCOMANIE (TC250)	ABZIEHBILD (TC250)	CALCOMANIA (TC250)	137
35A	DECALCOMANIE (TE250)	TRANSFER (TE250)	DECALCOMANIE (TE250)	ABZIEHBILD (TE250)	CALCOMANIA (TE250)	139
35B	DECALCOMANIE (TXC250)	TRANSFER (TXC250)	DECALCOMANIE (TXC250)	ABZIEHBILD (TXC250)	CALCOMANIA (TXC250)	141
35C	DECALCOMANIE (TE310)	TRANSFER (TE310)	DECALCOMANIE (TE310)	ABZIEHBILD (TE310)	CALCOMANIA (TE310)	143
35D	DECALCOMANIE (TXC310)	TRANSFER (TXC310)	DECALCOMANIE (TXC310)	ABZIEHBILD (TXC310)	CALCOMANIA (TXC310)	145
36	KIT CANISTER (USA)	KIT CANISTER (USA)	KIT CANISTER (USA)	KIT CANISTER (USA)	KIT CANISTER (USA)	147



**Husqvarna<sup>®</sup>**

---

**PAGINA INTENZIONALMENTE BIANCA  
INTENTIONALLY WHITE PAGE**

---

Tavola - Drawing - Table - Bild - Tabla

1

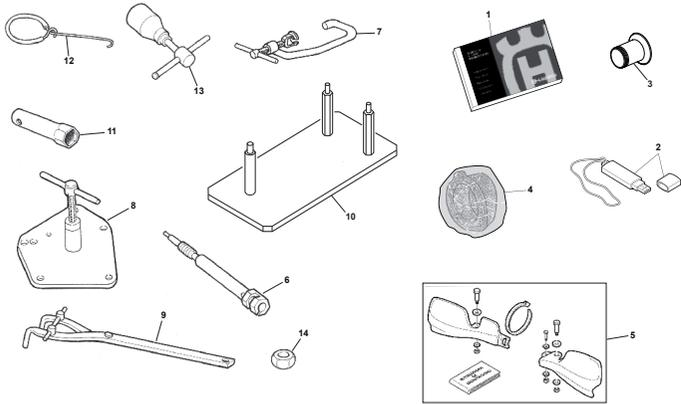

Pagina - Page - Page - Seite - Paja

16

Tavola - Drawing - Table - Bild - Tabla

2

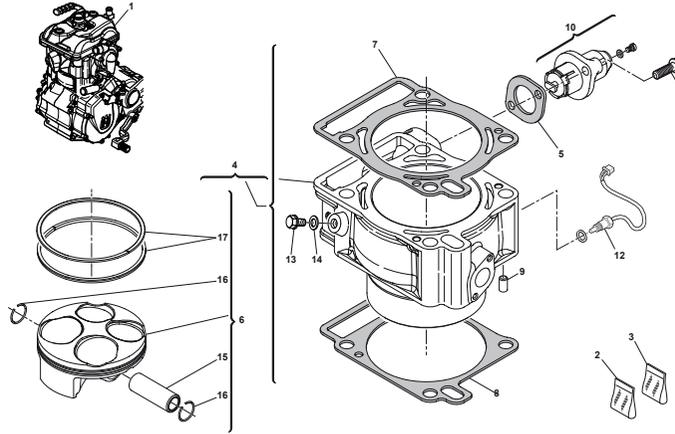

Pagina - Page - Page - Seite - Paja

18

Tavola - Drawing - Table - Bild - Tabla

3

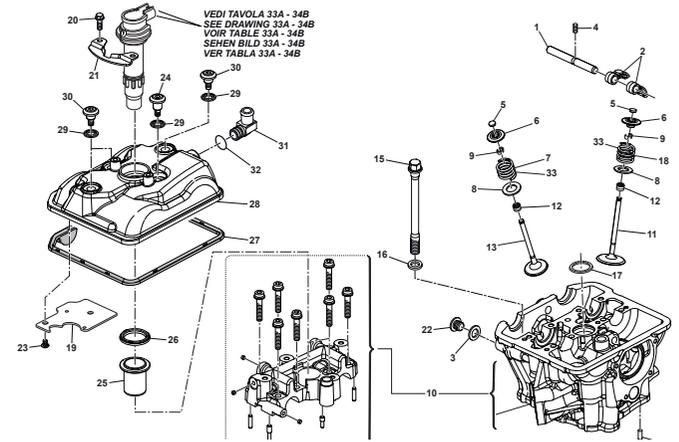

Pagina - Page - Page - Seite - Paja

20

Tavola - Drawing - Table - Bild - Tabla

4

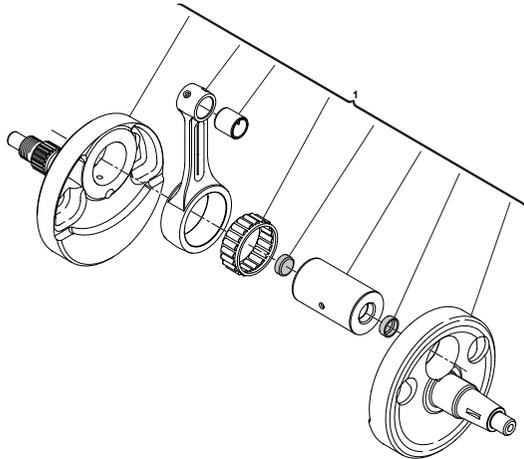

Pagina - Page - Page - Seite - Paja

24

Tavola - Drawing - Table - Bild - Tabla

5

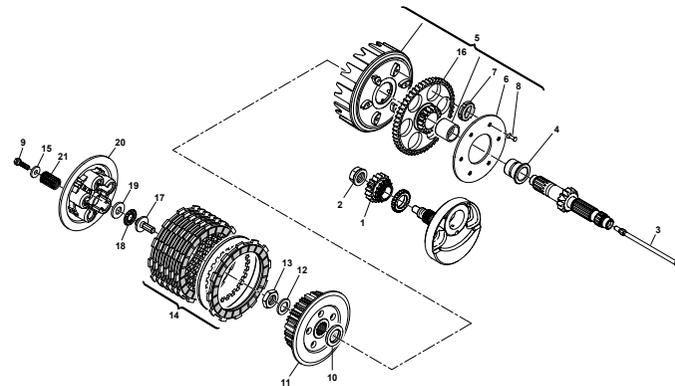

Pagina - Page - Page - Seite - Paja

26

Tavola - Drawing - Table - Bild - Tabla

6

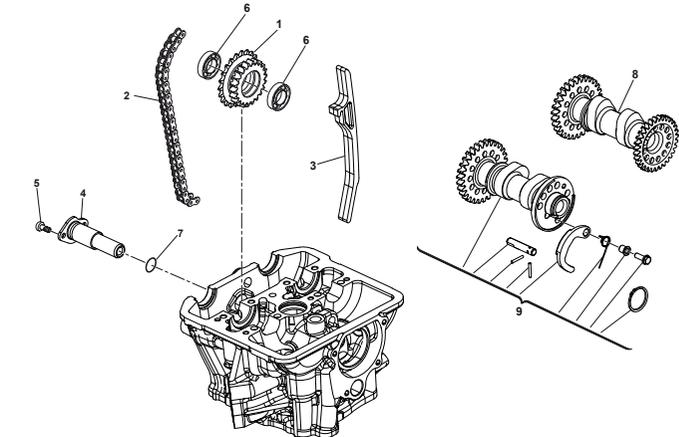

Pagina - Page - Page - Seite - Paja

28

Tavola - Drawing - Table - Bild - Tabla

7

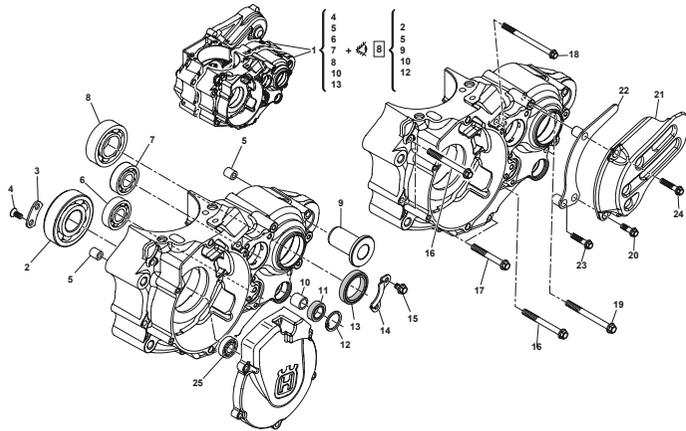

Pagina - Page - Page - Seite - Paja

30

Tavola - Drawing - Table - Bild - Tabla

8

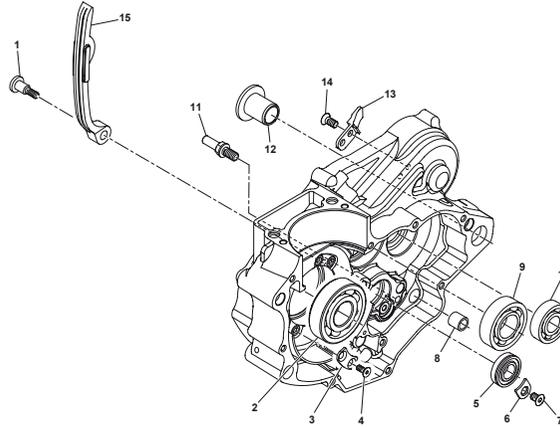

Pagina - Page - Page - Seite - Paja

32

Tavola - Drawing - Table - Bild - Tabla

9

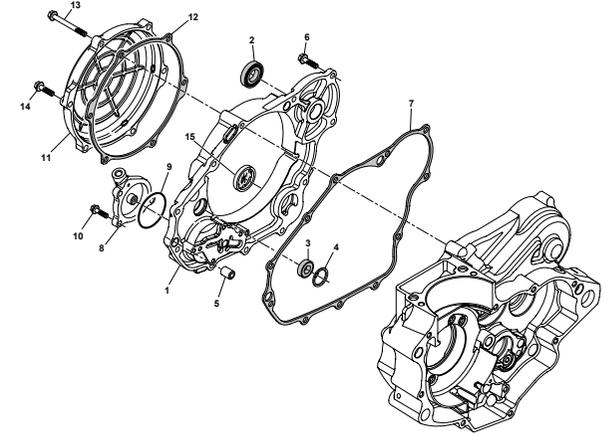

Pagina - Page - Page - Seite - Paja

34

Tavola - Drawing - Table - Bild - Tabla

10

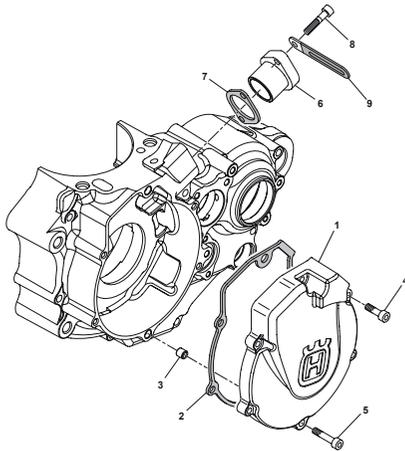

Pagina - Page - Page - Seite - Paja

36

Tavola - Drawing - Table - Bild - Tabla

11

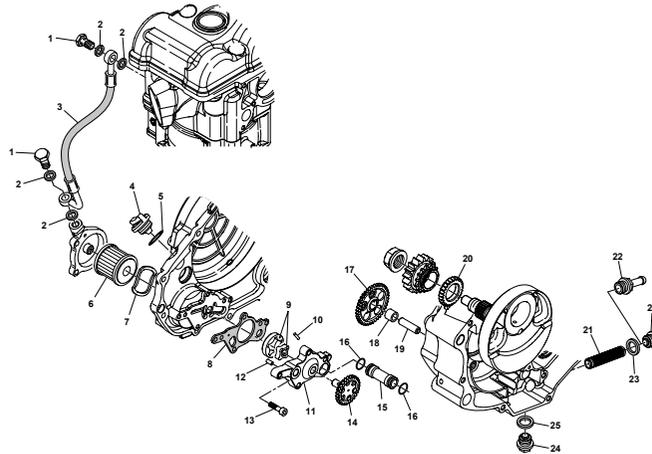

Pagina - Page - Page - Seite - Paja

38

Tavola - Drawing - Table - Bild - Tabla

12

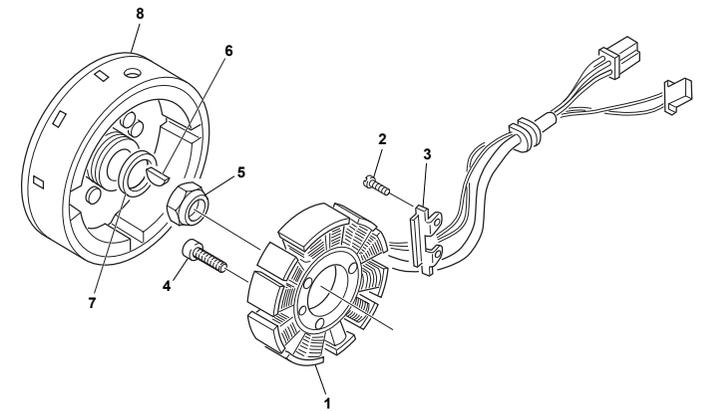

Pagina - Page - Page - Seite - Paja

40

Tavola - Drawing - Table - Bild - Tabla

13

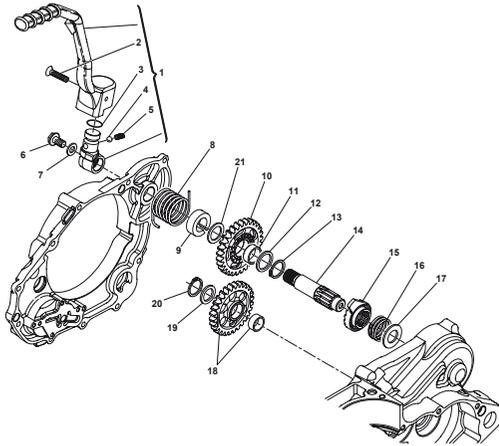

Pagina - Page - Page - Seite - Paja

42

Tavola - Drawing - Table - Bild - Tabla

13A

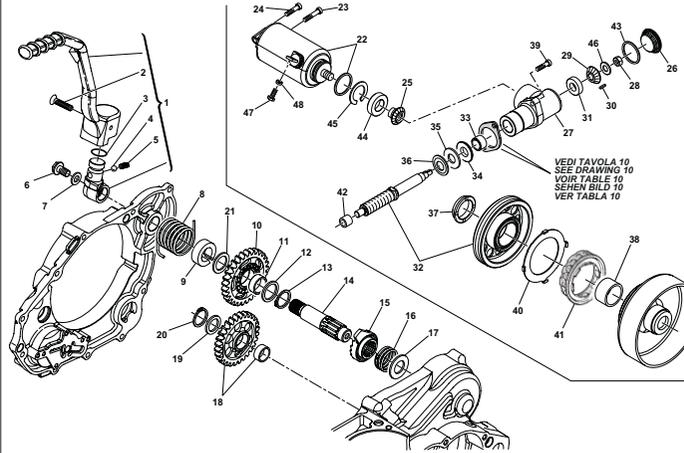

Pagina - Page - Page - Seite - Paja

44

Tavola - Drawing - Table - Bild - Tabla

14

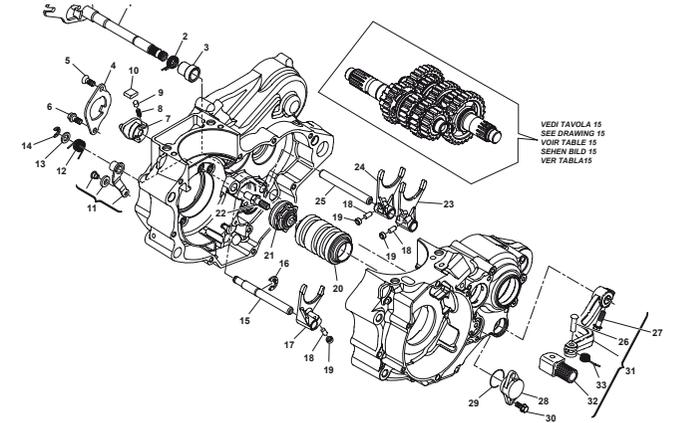

Pagina - Page - Page - Seite - Paja

48

Tavola - Drawing - Table - Bild - Tabla

14A

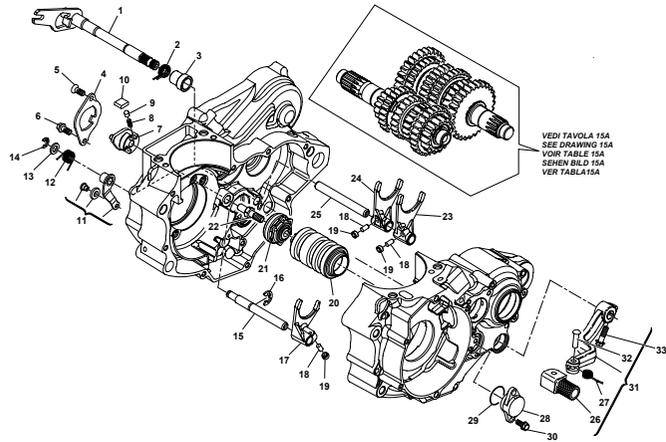

Pagina - Page - Page - Seite - Paja

50

Tavola - Drawing - Table - Bild - Tabla

15

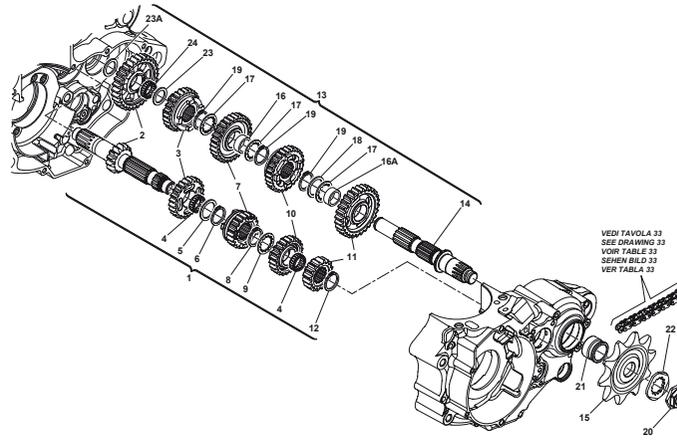

Pagina - Page - Page - Seite - Paja

52

Tavola - Drawing - Table - Bild - Tabla

15A

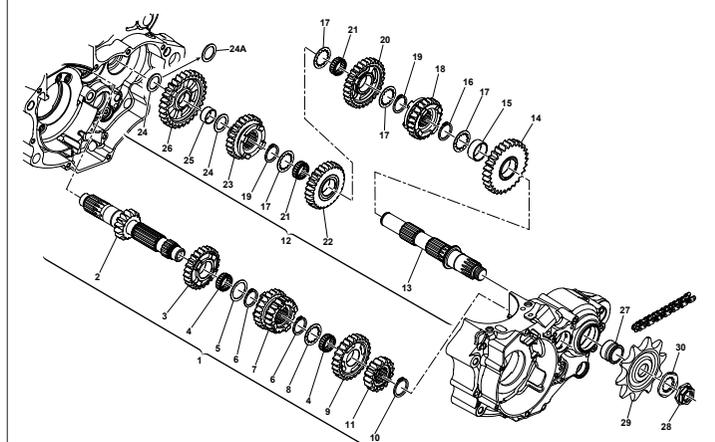

Pagina - Page - Page - Seite - Paja

54



Tavola - Drawing - Table - Bild - Tabla

16

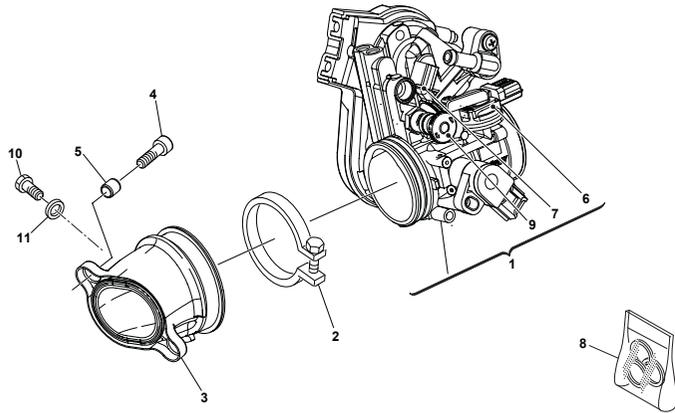

Pagina - Page - Page - Seite - Paja

56

Tavola - Drawing - Table - Bild - Tabla

17

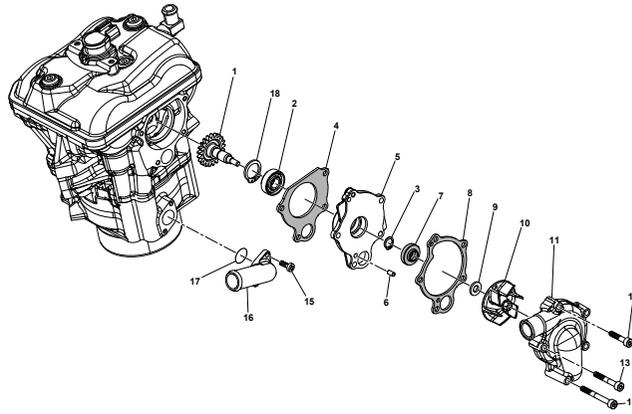

Pagina - Page - Page - Seite - Paja

58

Tavola - Drawing - Table - Bild - Tabla

18

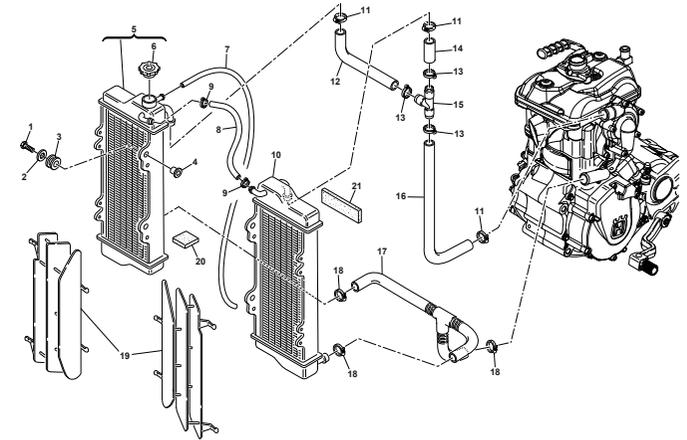

Pagina - Page - Page - Seite - Paja

60

Tavola - Drawing - Table - Bild - Tabla

18A

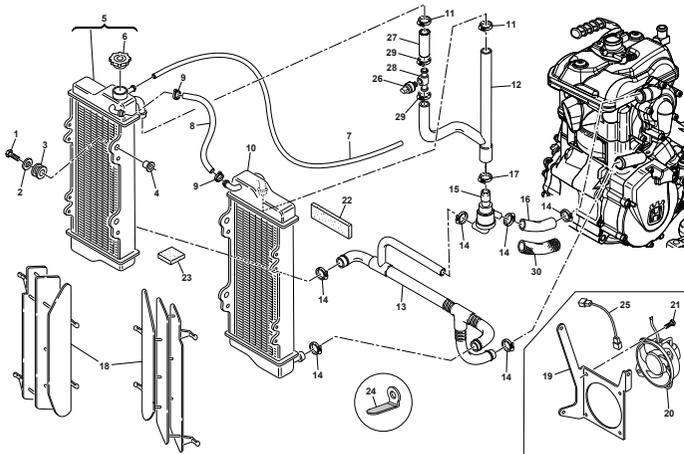

Pagina - Page - Page - Seite - Paja

62

Tavola - Drawing - Table - Bild - Tabla

19

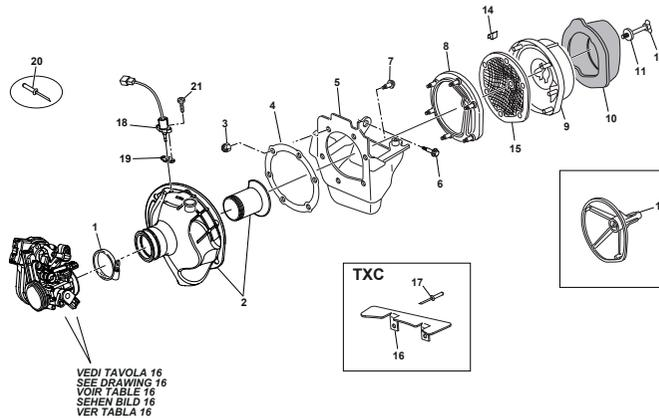

Pagina - Page - Page - Seite - Paja

64

Tavola - Drawing - Table - Bild - Tabla

19A

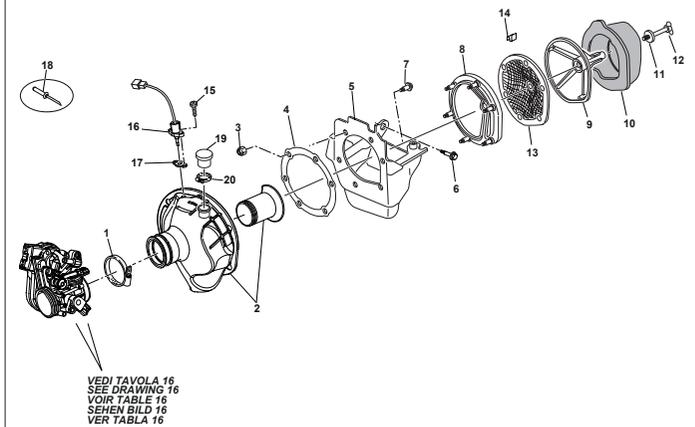

Pagina - Page - Page - Seite - Paja

66

Tavola - Drawing - Table - Bild - Tabla

19B

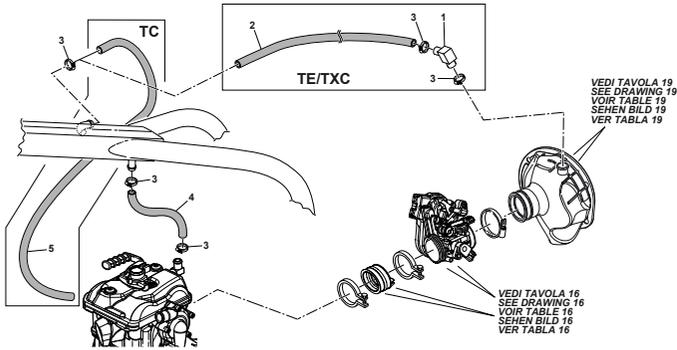

Pagina - Page - Page - Seite - Paja

68

Tavola - Drawing - Table - Bild - Tabla

19C

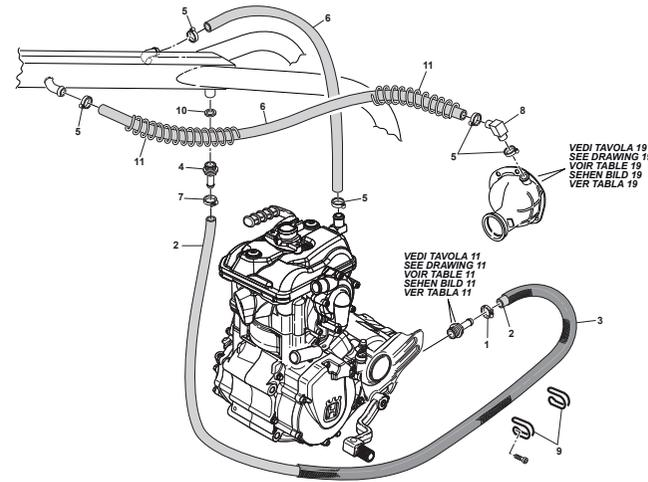

Pagina - Page - Page - Seite - Paja

70

Tavola - Drawing - Table - Bild - Tabla

20

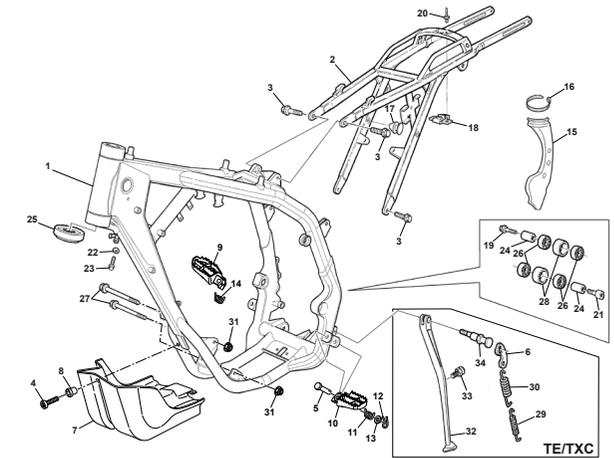

Pagina - Page - Page - Seite - Paja

72

Tavola - Drawing - Table - Bild - Tabla

21

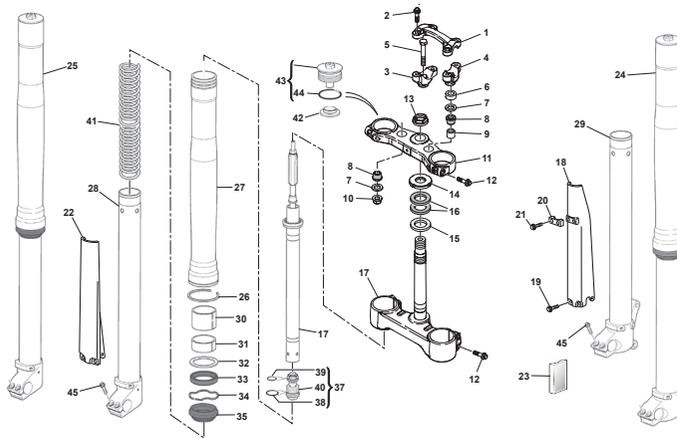

Pagina - Page - Page - Seite - Paja

76

Tavola - Drawing - Table - Bild - Tabla

21A

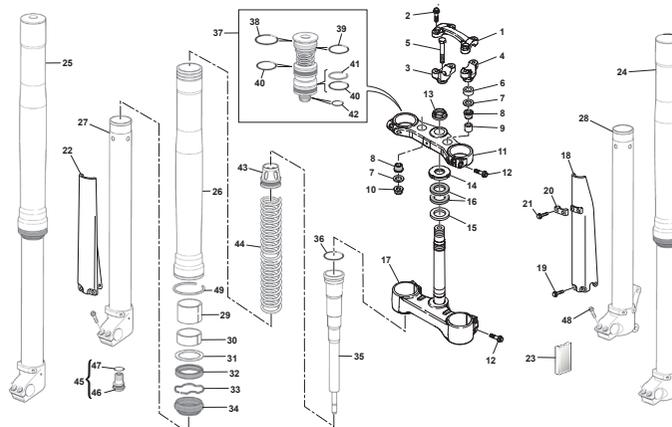

Pagina - Page - Page - Seite - Paja

80

Tavola - Drawing - Table - Bild - Tabla

22

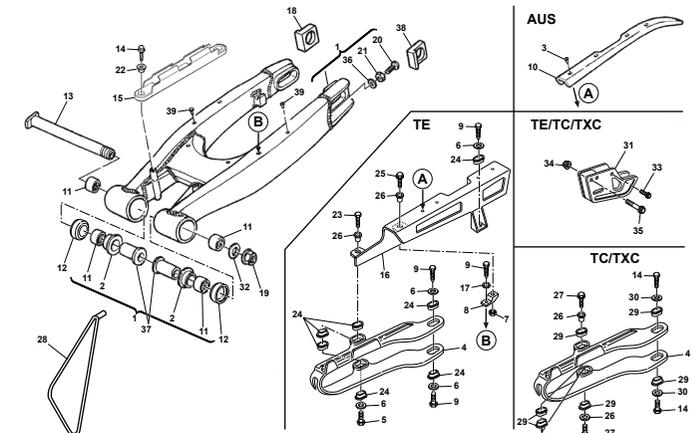

Pagina - Page - Page - Seite - Paja

84

Tavola - Drawing - Table - Bild - Tabla

23

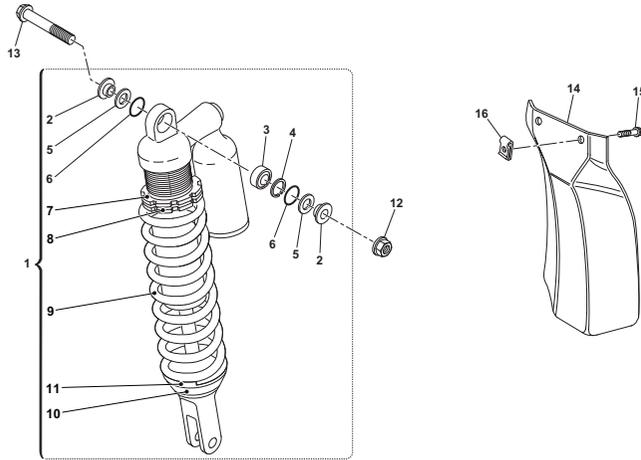

Pagina - Page - Page - Seite - Paja

88

Tavola - Drawing - Table - Bild - Tabla

23A

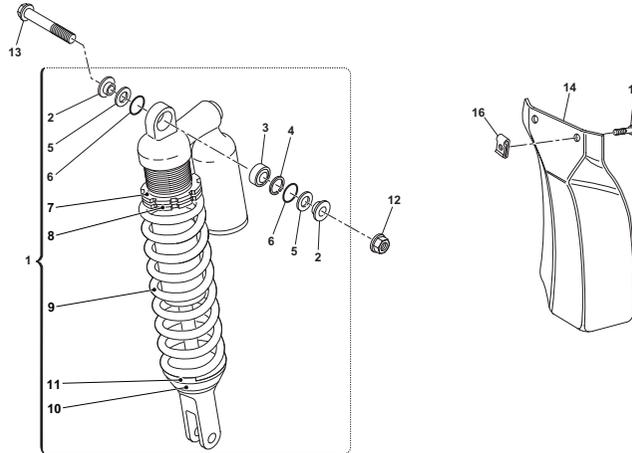

Pagina - Page - Page - Seite - Paja

90

Tavola - Drawing - Table - Bild - Tabla

24

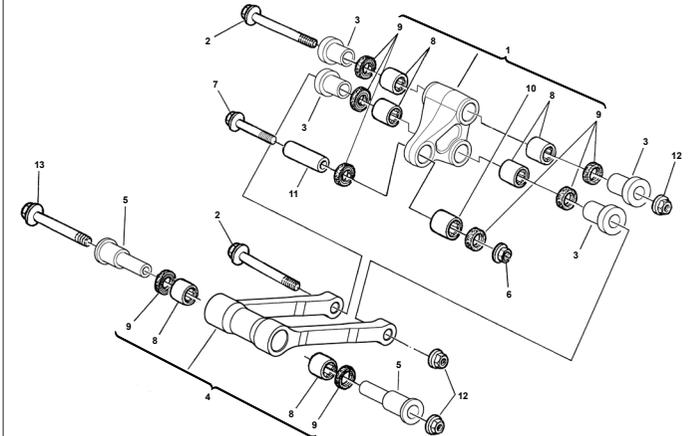

Pagina - Page - Page - Seite - Paja

92

Tavola - Drawing - Table - Bild - Tabla

25

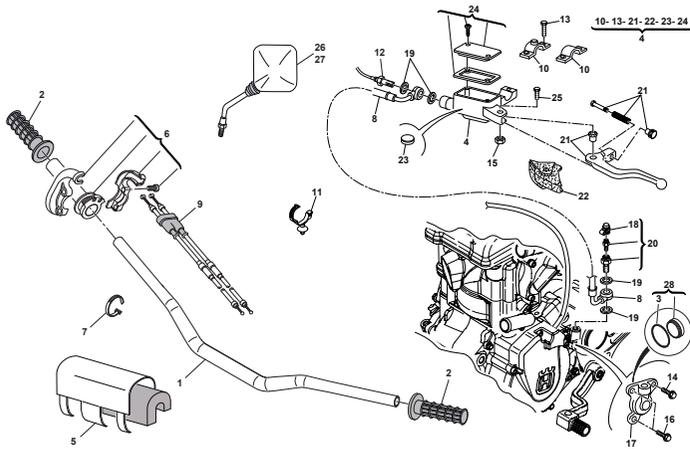

Pagina - Page - Page - Seite - Paja

94

Tavola - Drawing - Table - Bild - Tabla

26

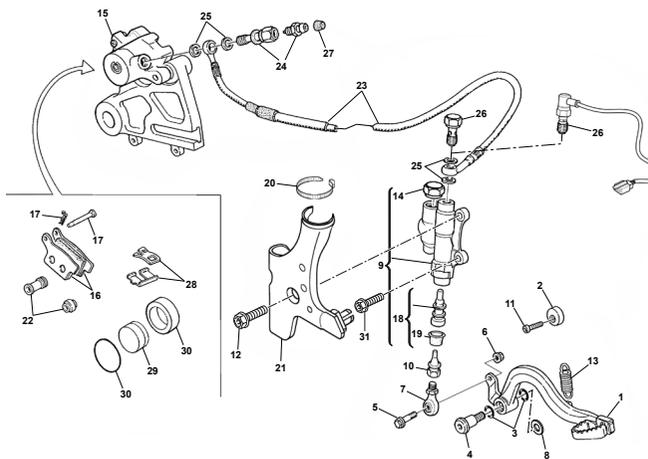

Pagina - Page - Page - Seite - Paja

96

Tavola - Drawing - Table - Bild - Tabla

27

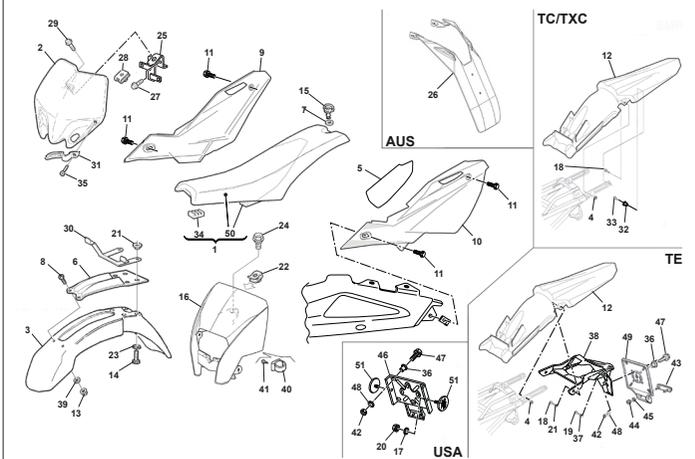

Pagina - Page - Page - Seite - Paja

100

Tavola - Drawing - Table - Bild - Tabla

28

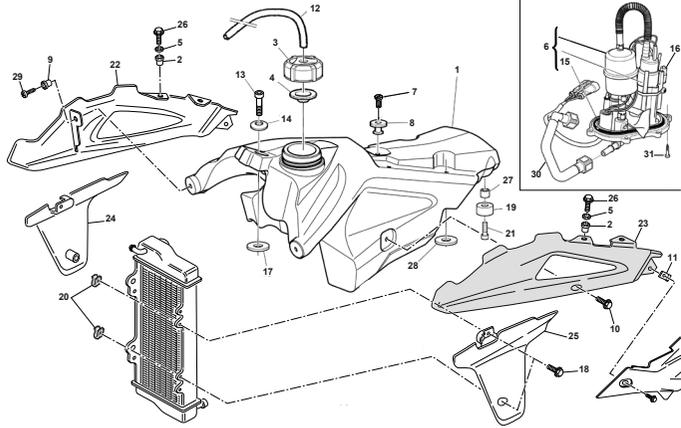

Pagina - Page - Page - Seite - Paja

104

Tavola - Drawing - Table - Bild - Tabla

28A

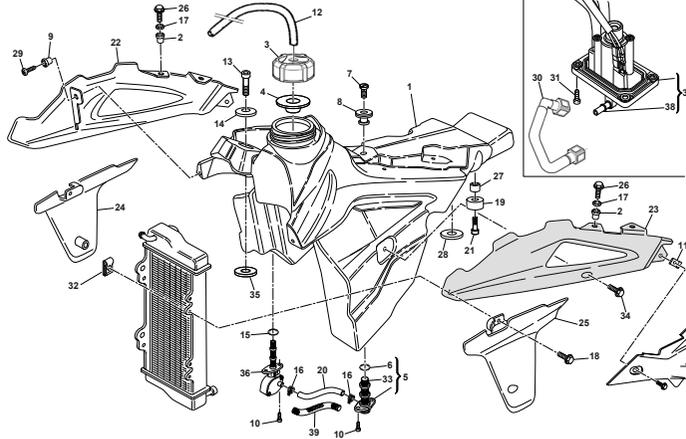

Pagina - Page - Page - Seite - Paja

106

Tavola - Drawing - Table - Bild - Tabla

29

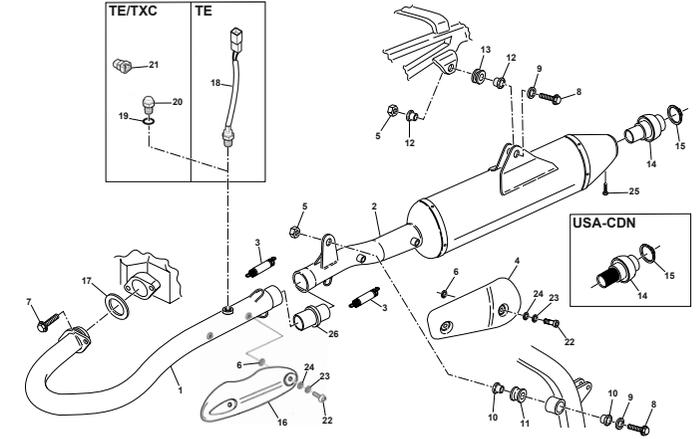

Pagina - Page - Page - Seite - Paja

110

Tavola - Drawing - Table - Bild - Tabla

29A

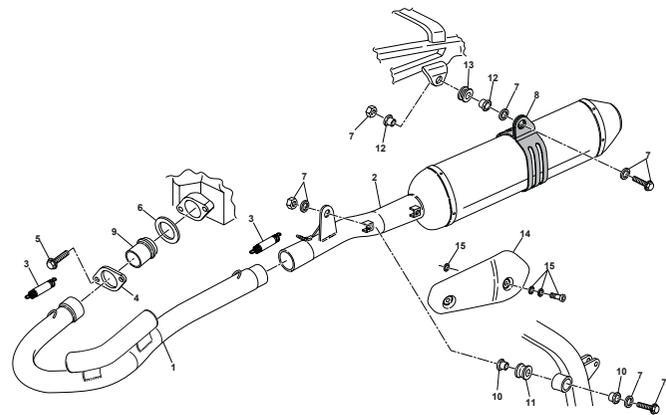

Pagina - Page - Page - Seite - Paja

112

Tavola - Drawing - Table - Bild - Tabla

30

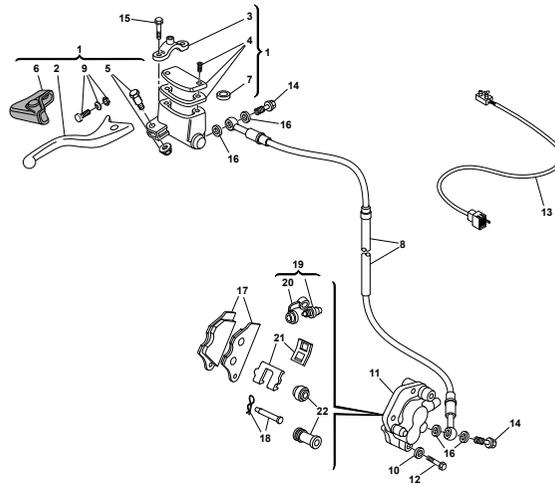

Pagina - Page - Page - Seite - Paja

114

Tavola - Drawing - Table - Bild - Tabla

31

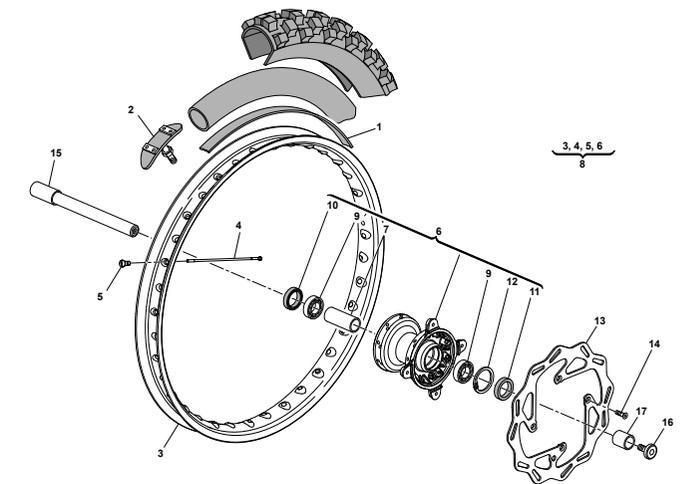

Pagina - Page - Page - Seite - Paja

116

Tavola - Drawing - Table - Bild - Tabla

32

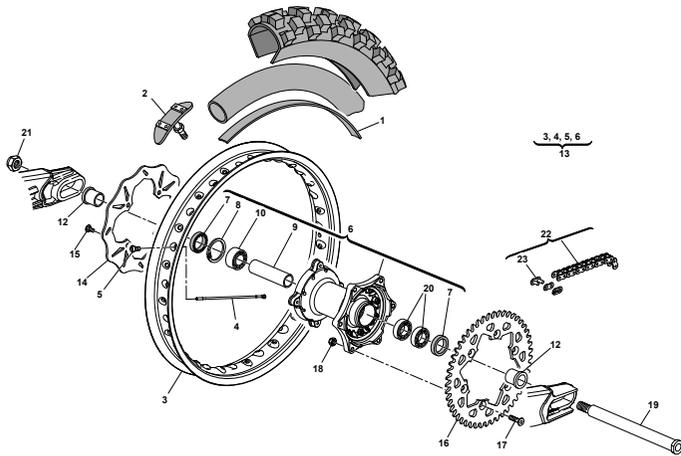

Pagina - Page - Page - Seite - Paja

118

Tavola - Drawing - Table - Bild - Tabla

33

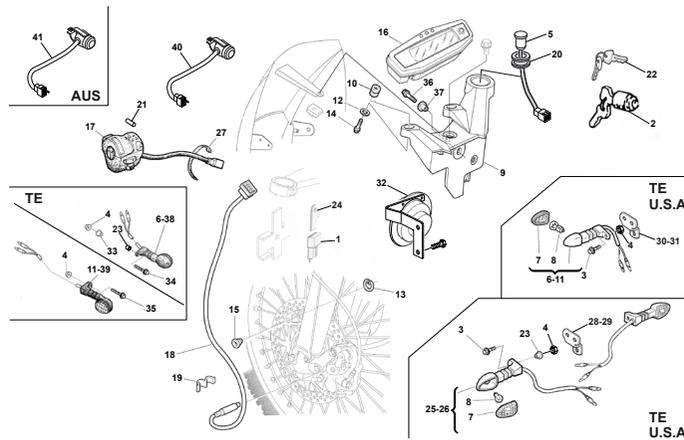

Pagina - Page - Page - Seite - Paja

122

Tavola - Drawing - Table - Bild - Tabla

33A

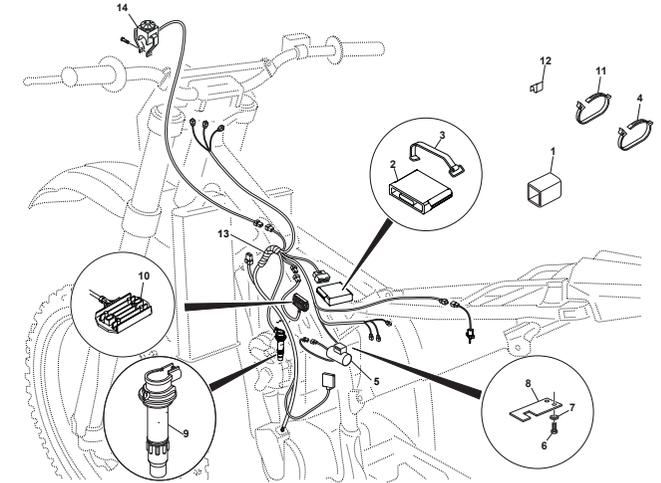

Pagina - Page - Page - Seite - Paja

126

Tavola - Drawing - Table - Bild - Tabla

34

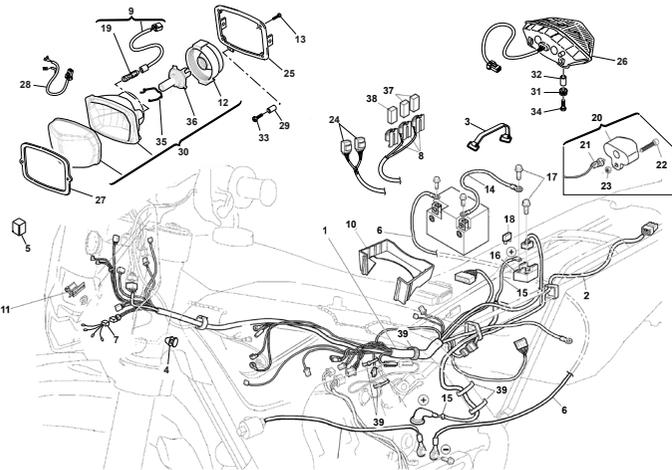

Pagina - Page - Page - Seite - Paja

128

Tavola - Drawing - Table - Bild - Tabla

34A

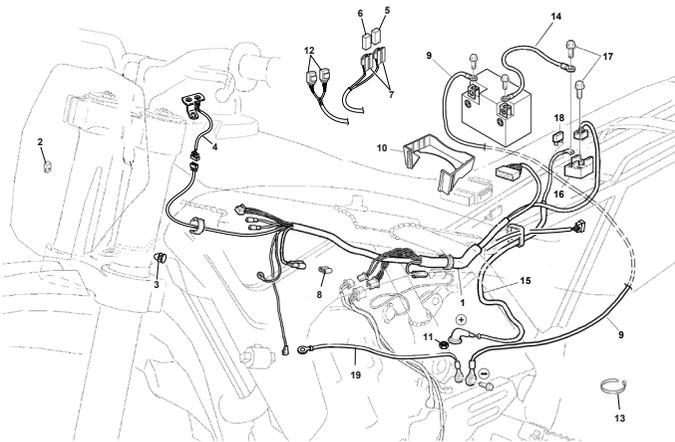

Pagina - Page - Page - Seite - Paja

132

Tavola - Drawing - Table - Bild - Tabla

34B

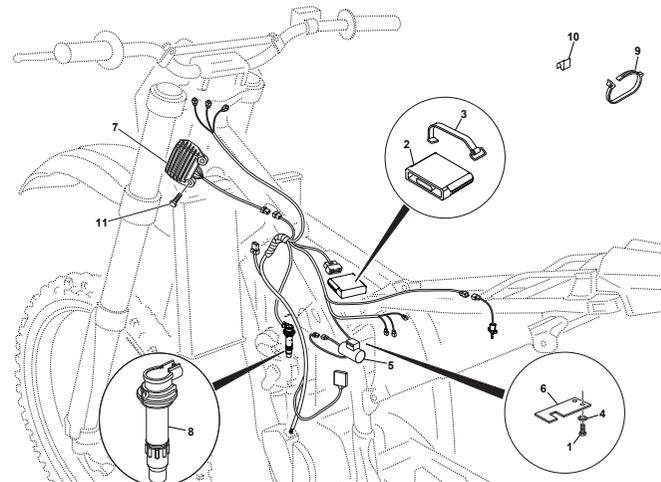

Pagina - Page - Page - Seite - Paja

134

Tavola - Drawing - Table - Bild - Tabla

35

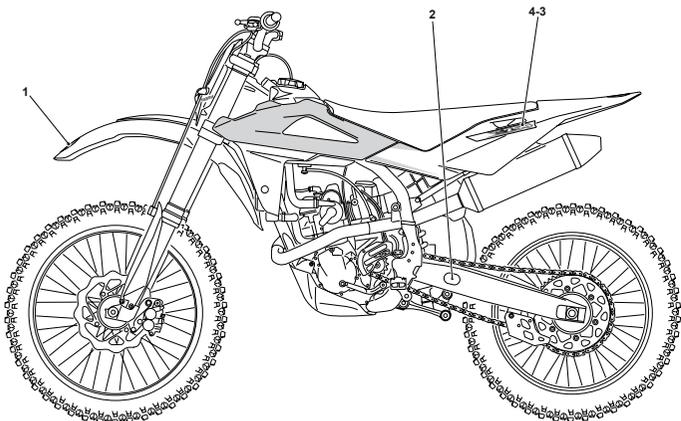

Pagina - Page - Page - Seite - Paja

136

Tavola - Drawing - Table - Bild - Tabla

35A

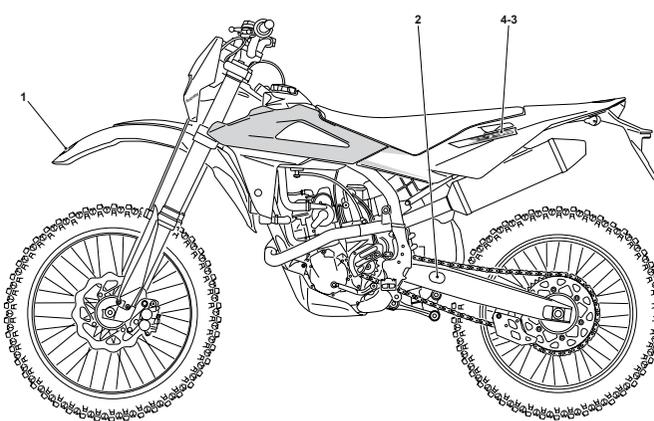

Pagina - Page - Page - Seite - Paja

138

Tavola - Drawing - Table - Bild - Tabla

35B

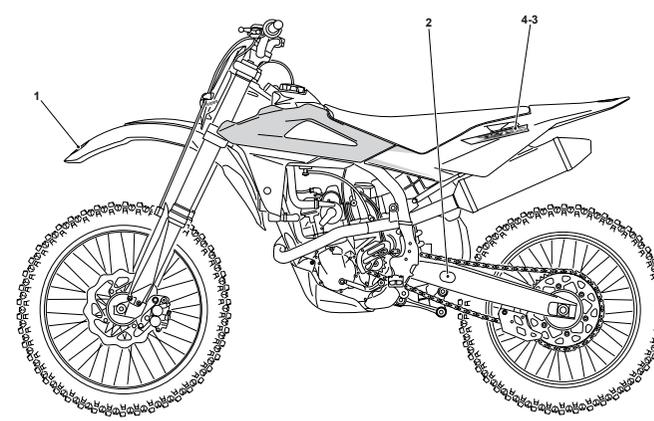

Pagina - Page - Page - Seite - Paja

140

Tavola - Drawing - Table - Bild - Tabla

35C

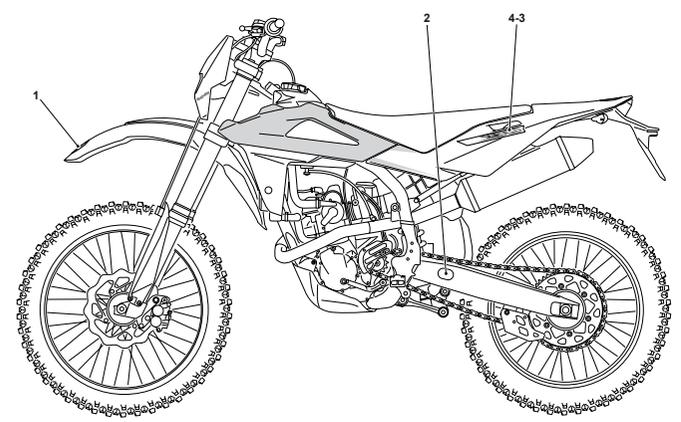

Pagina - Page - Page - Seite - Paja

142

Tavola - Drawing - Table - Bild - Tabla

35D

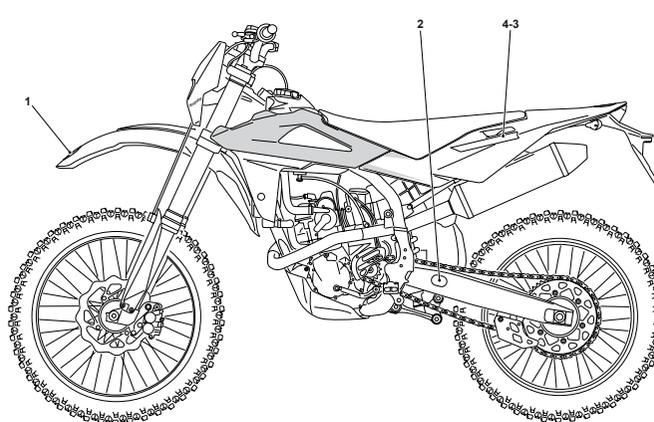

Pagina - Page - Page - Seite - Paja

144

Tavola - Drawing - Table - Bild - Tabla

36

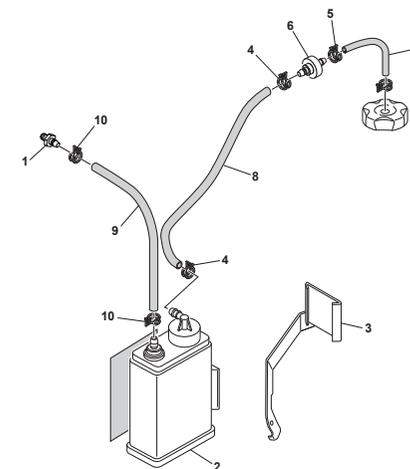

Pagina - Page - Page - Seite - Paja

146



**Husqvarna®**

---

**PAGINA INTENZIONALMENTE BIANCA  
INTENTIONALLY WHITE PAGE**

---

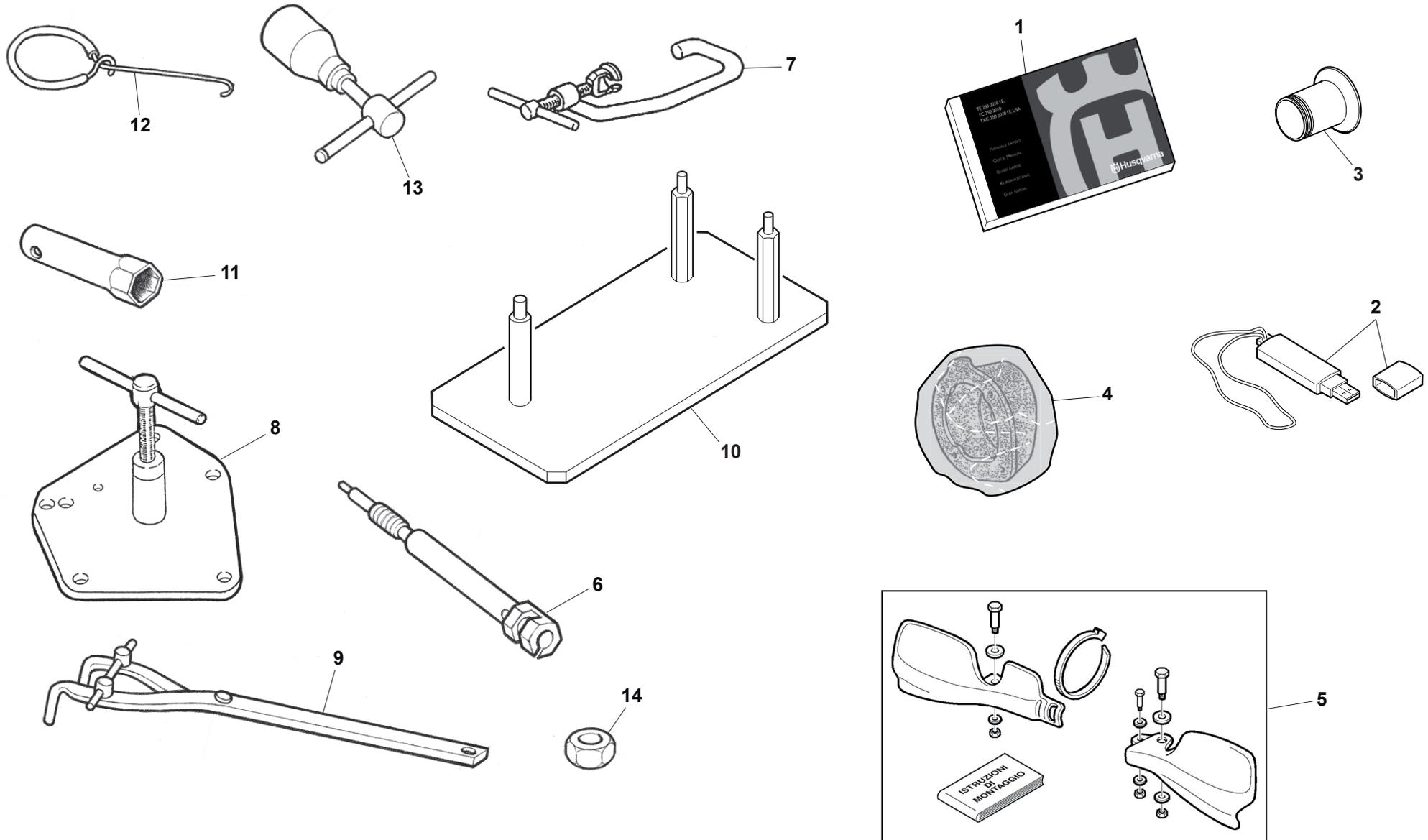





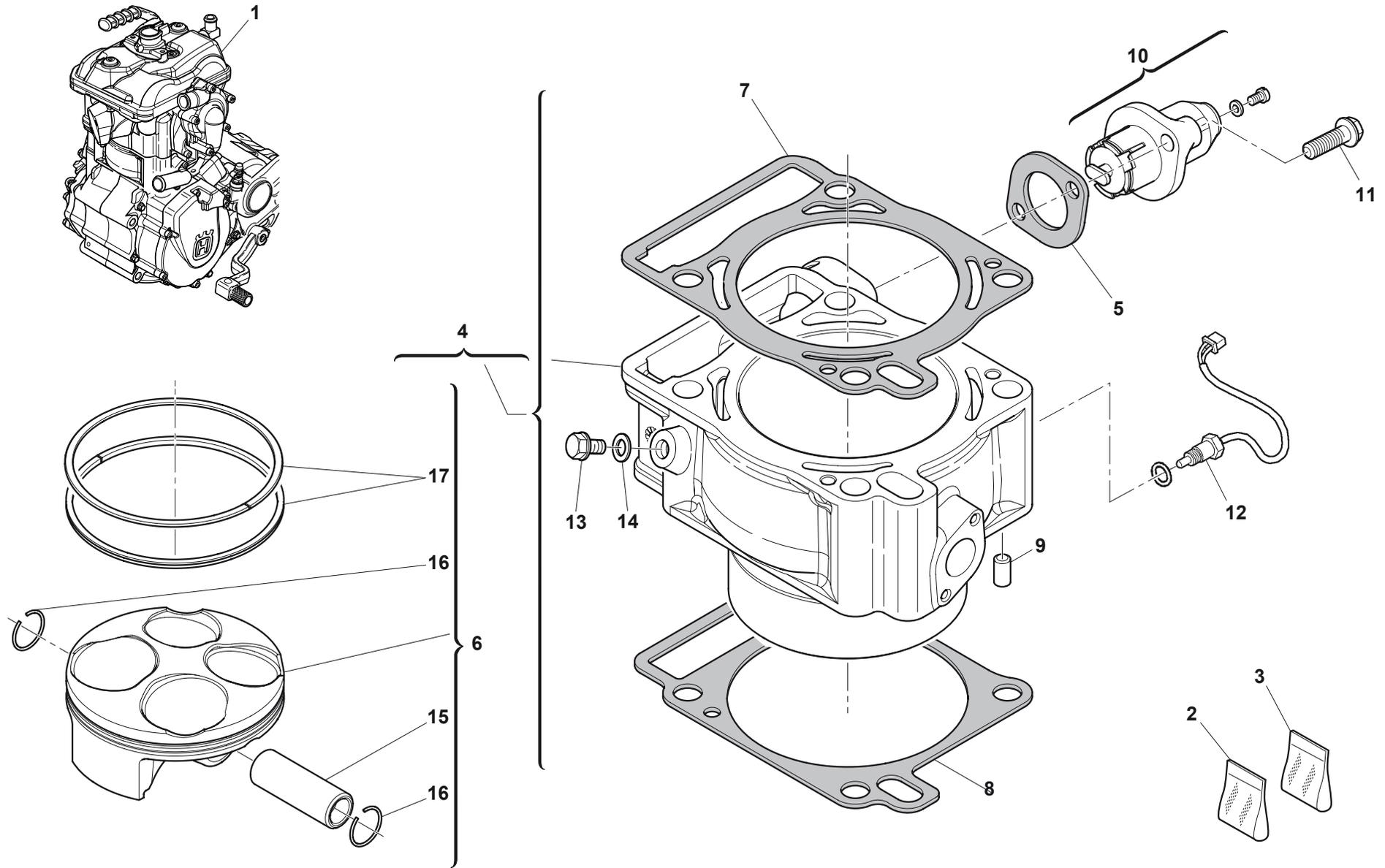



VEDI TAVOLA 33A - 34B  
SEE DRAWING 33A - 34B  
VOIR TABLE 33A - 34B  
SEHEN BILD 33A - 34B  
VER TABLA 33A - 34B

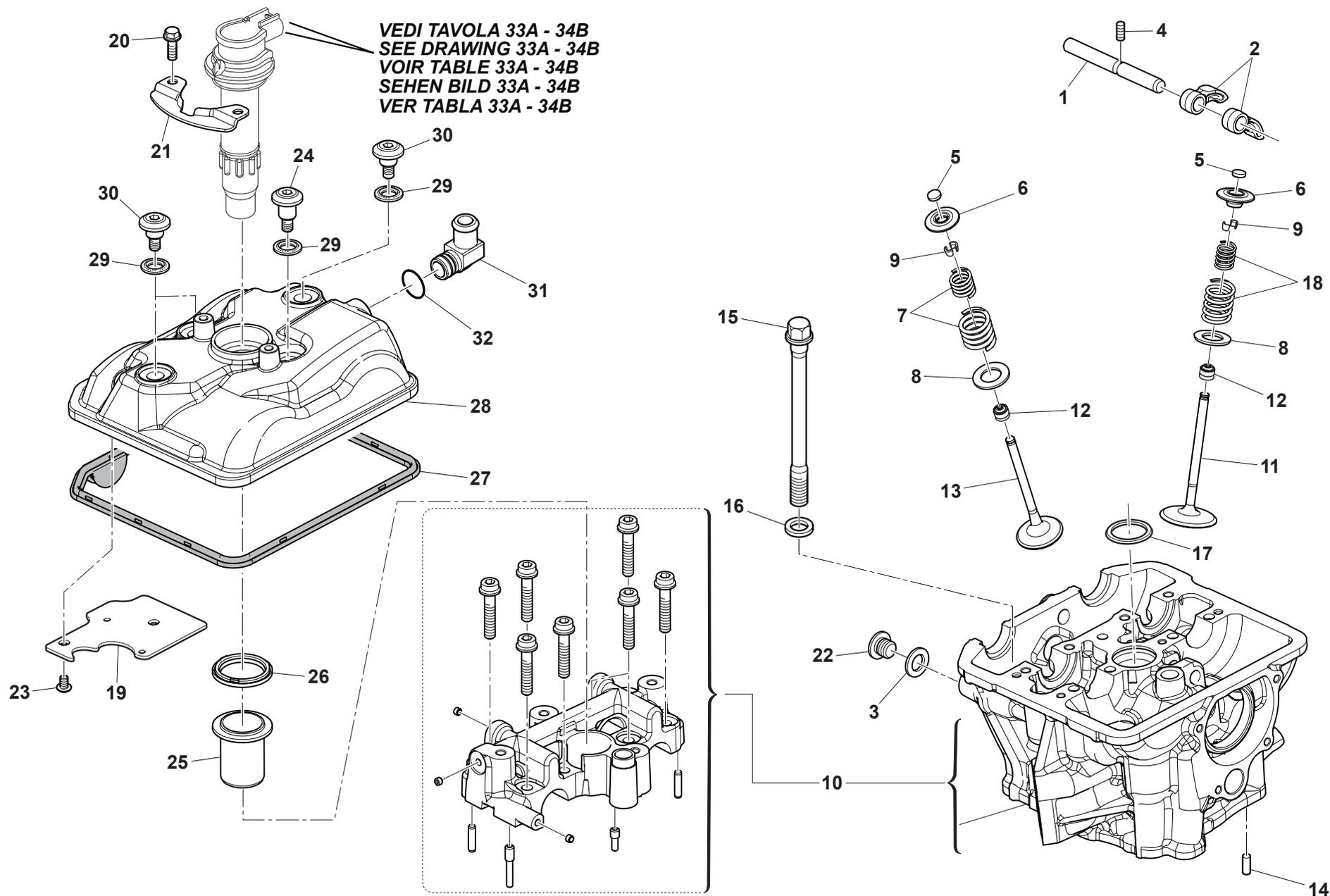

**TE-TXC-TC 250/2013**  
**TE-TXC 310/2013**

TAVOLA - DRAWING  
 TABLE - BILD - TABLA

**3**

**TESTA CILINDRO - CYLINDER HEAD**  
**CULASSE - ZYLINDERKOPF**  
**CULATA**



Note Notes Notes Marke Notas	Pos. No. N. Index Pos.	N. Cod. Code No. Nr. Code Code Nr N. Cod.	Q.tà Q.ty Q.te M.ge C.ad	DENOMINAZIONE	NAME	DESIGNATION	BESHREIBUNG	DENOMINACION
	1	8000 H6098	2	Perno	Pin	Pivot	Bolzen	Perno
	2	8000 H6099	4	Bilanciere	Rocking lever	Balancier	Schwinge	Balancines
	3	62N0 15676	2	Rosetta	Washer	Rondelle	Scheibe	Arandela
	4	8000 H6293	1	Vite fissaggio perno bilanciere SCARICO	Rocking lever screw EXHAUST	Vis pour balancier ECHAPPEMENT	Schraube AUSPUFFSEITE	Tornillo por perno DESCARGA
	4	8000 H6294	1	Vite fissaggio perno bilanciere ASPIRAZIONE	Rocking lever screw INTAKE	Vis pour balancier ADMISSION	Schraube ANSAUGSEITE	Tornillo por perno ASPIRACION
	5	8000 A2141	4	Pastiglia (1,60 mm)	Pad (1,60 mm)	Plaquette (1,60 mm)	Belag (1,60 mm)	Pastilla (1,60 mm)
	5	8A00 A2141	4	Pastiglia (1,65 mm)	Pad (1,65 mm)	Plaquette (1,65 mm)	Belag (1,65 mm)	Pastilla (1,65 mm)
	5	8B00 A2141	4	Pastiglia (1,70 mm)	Pad (1,70 mm)	Plaquette (1,70 mm)	Belag (1,70 mm)	Pastilla (1,70 mm)
	5	8C00 A2141	4	Pastiglia (1,75 mm)	Pad (1,75 mm)	Plaquette (1,75 mm)	Belag (1,75 mm)	Pastilla (1,75 mm)
	5	8D00 A2141	4	Pastiglia (1,80 mm)	Pad (1,80 mm)	Plaquette (1,80 mm)	Belag (1,80 mm)	Pastilla (1,80 mm)
	5	8E00 A2141	4	Pastiglia (1,85 mm)	Pad (1,85 mm)	Plaquette (1,85 mm)	Belag (1,85 mm)	Pastilla (1,85 mm)
	5	8F00 A2141	4	Pastiglia (1,90 mm)	Pad (1,90 mm)	Plaquette (1,90 mm)	Belag (1,90 mm)	Pastilla (1,90 mm)
	5	8G00 A2141	4	Pastiglia (1,95 mm)	Pad (1,95 mm)	Plaquette (1,95 mm)	Belag (1,95 mm)	Pastilla (1,95 mm)
	5	8H00 A2141	4	Pastiglia (2,00 mm)	Pad (2,00 mm)	Plaquette (2,00 mm)	Belag (2,00 mm)	Pastilla (2,00 mm)
	5	8J00 A2141	4	Pastiglia (2,05 mm)	Pad (2,05 mm)	Plaquette (2,05 mm)	Belag (2,05 mm)	Pastilla (2,05 mm)
	5	8K00 A2141	4	Pastiglia (2,10 mm)	Pad (2,10 mm)	Plaquette (2,10 mm)	Belag (2,10 mm)	Pastilla (2,10 mm)
	5	8L00 A2141	4	Pastiglia (2,15 mm)	Pad (1,60 mm)	Plaquette (1,60 mm)	Belag (1,60 mm)	Pastilla (1,60 mm)
	5	8M00 A2141	4	Pastiglia (2,20 mm)	Pad (2,20 mm)	Plaquette (2,20 mm)	Belag (2,20 mm)	Pastilla (2,20 mm)
	5	8N00 A2141	4	Pastiglia (2,25 mm)	Pad (2,25 mm)	Plaquette (2,25 mm)	Belag (2,25 mm)	Pastilla (2,25 mm)
	5	8P00 A2141	4	Pastiglia (2,30 mm)	Pad (2,30 mm)	Plaquette (2,30 mm)	Belag (2,30 mm)	Pastilla (2,30 mm)
	5	8R00 A2141	4	Pastiglia (2,35 mm)	Pad (2,35 mm)	Plaquette (2,35 mm)	Belag (2,35 mm)	Pastilla (2,35 mm)
	5	8S00 A2141	4	Pastiglia (2,40 mm)	Pad (2,40 mm)	Plaquette (2,40 mm)	Belag (2,40 mm)	Pastilla (2,40 mm)
	5	8T00 A2141	4	Pastiglia (2,45 mm)	Pad (2,45 mm)	Plaquette (2,45 mm)	Belag (2,45 mm)	Pastilla (2,45 mm)
	5	8U00 A2141	4	Pastiglia (2,50 mm)	Pad (2,50 mm)	Plaquette (2,50 mm)	Belag (2,50 mm)	Pastilla (2,50 mm)
	5	8V00 A2141	4	Pastiglia (2,55 mm)	Pad (2,55 mm)	Plaquette (2,55 mm)	Belag (2,55 mm)	Pastilla (2,55 mm)
	5	8W00 A2141	4	Pastiglia (2,60 mm)	Pad (2,60 mm)	Plaquette (2,60 mm)	Belag (2,60 mm)	Pastilla (2,60 mm)
	6	8000 H5895	4	Piattello	Disc	Disque	Scheibe	Disco
C	7	8000 H6219	2	Molla per valvola	Needle valve clip	Ressort	Feder	Resorte
BKTW	7	8000 H5896	2	Molla per valvola	Needle valve clip	Ressort	Feder	Resorte
	8	8000 H5894	4	Rosetta per molla	Washer	Rondelle	Scheibe	Arandela
	9	8000 H5941	8	Semicono	Half cone	Demi-cône	Halb Kegel	Semi-cono
	10	8000 H5401	1	Testa cilindro	Cylinder head	Culasse cylindre	Zylinderkopf	Culada cilindro
BKTW	11	8538521	2	Valvola aspirazione	Inlet valve	Soupape admission	Einlass-Ventil	Válvula aspiración

VEDI TAVOLA 33A - 34B  
SEE DRAWING 33A - 34B  
VOIR TABLE 33A - 34B  
SEHEN BILD 33A - 34B  
VER TABLA 33A - 34B

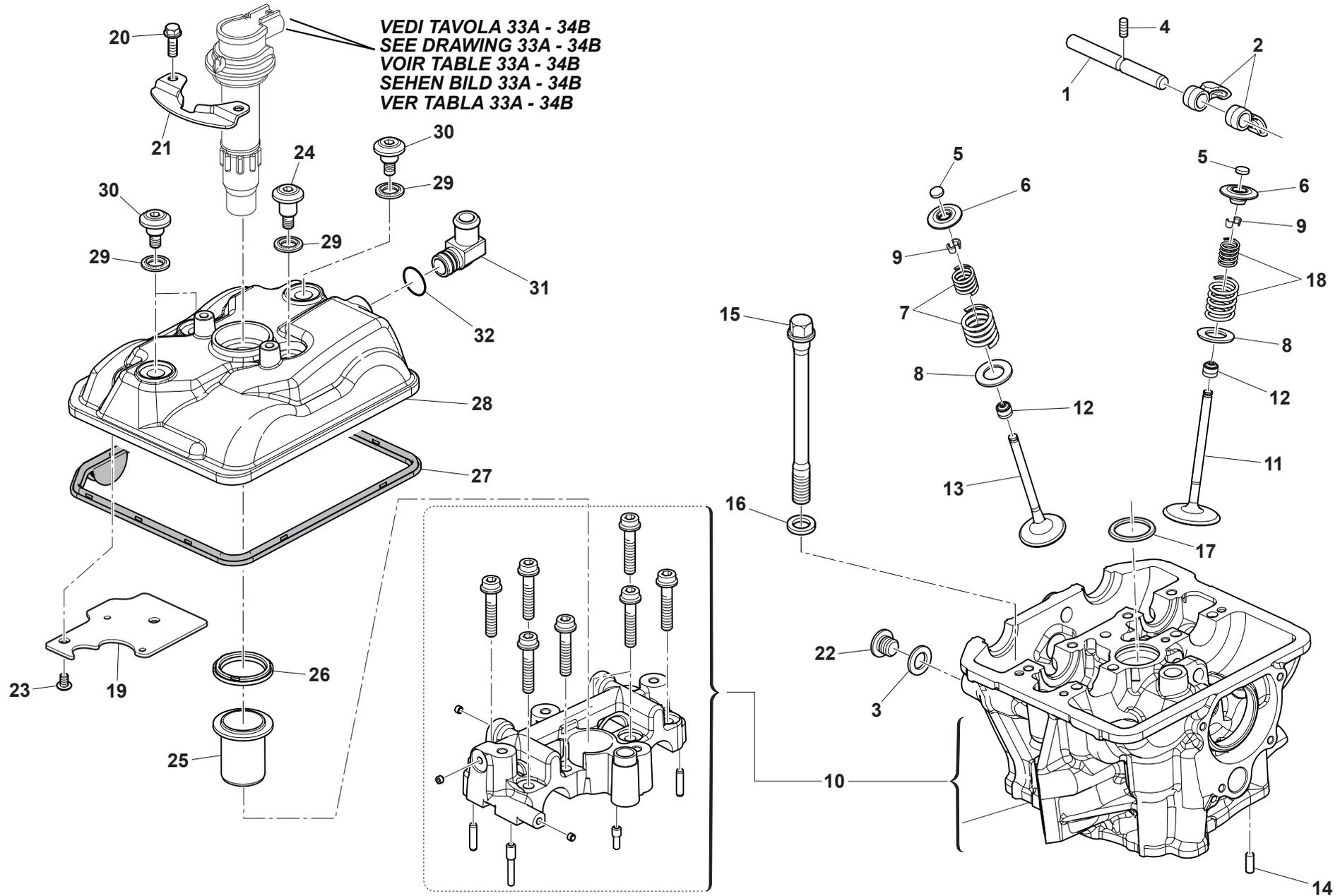

TE-TXC-TC 250/2013  
TE-TXC 310/2013

TAVOLA - DRAWING  
TABLE - BILD - TABLA

3

TESTA CILINDRO - CYLINDER HEAD  
CULASSE - ZYLINDERKOPF  
CULATA



Note Notes Marke Notas	Pos. No. Index Pos.	N. Cod. Code No. Nr. Code Code Nr N. Cod.	Q.tà Q.ty Q.te M.ge C.ad	DENOMINAZIONE	NAME	DESIGNATION	BESHREIBUNG	DENOMINACION
C	11	8539056	2	Valvola di aspirazione	Inlet valve	Soupape admission	Einlass-Ventil	Válvula aspiración
	12	8000 H5947	4	Anello di tenuta	Valves seal ring	Bague de retenue soupapes	Dichtring	Anillo de retención valvula
C	13	8000 H5958	2	Valvola di scarico	Exhaust valve	Soupape d'échappement	Auslassventil	Válvula de escape
BKTW	13	8538522	2	Valvola scarico	Exhaust valve	Auslassventil	Soupape d'échappement	Válvula de escape
	14	8000 A6939	2	Spina	Dowel	Plot	Zylinderst	Centraje
TC	15	8000 A6564	4	Prigioniero	Stud bolt	Prisonnier	Stiftschraube	Prisionero
BK	15	8B00 A6564	4	Prigioniero	Stud bolt	Prisonnier	Stiftschraube	Prisionero
	16	Z000 23374	4	Rosetta	Washer	Rondelle	Scheibe	Arandela
	17	8A00 42700	1	Anello OR 23,52x1,78	O-Ring 23,52x1,78	Bague OR 23,52x1,78	O Ring 23,52x1,78	Anillo OR 23,52x1,78
	18	8000 H5896	2	Molla per valvola	Needle valve clip	Ressort	Feder	Resorte
	19	8000 H6133	1	Piastrina blow-by	Blow-by plate	Plaque blow-by	Platte blow-by	Placa blow-by
	20	Z000 62728	2	Vite	Screw	Vis	Schraube	Tornillo
	21	8000 H7283	1	Piastrina	Plate	Plaque	Platte	Placa
	22	8000 H6571	2	Tappo	Plug	Bouchon	Verschluss	Tapón
	23	ZC00 65535	2	Vite	Screw	Vis	Schraube	Tornillo
	24	8000 H6582	1	Vite	Screw	Vis	Schraube	Tornillo
	25	8000 H5410	1	Boccola	Bushing	Douille	Buchse	Buje
	26	8000 H6078	1	Guarnizione	Gasket	Garniture	Dichtung	Junta
	27	8000 H6077	1	Guarnizione coperchio testa	Cylinder head cover Gasket	Garnitue couvercle culasse	Dichtung	Junta tapa culata
	28	80A0 H6337	1	Coperchio testa	Cylinder head cover	Couvercle culasse	Zylinderkopfabdeckung	Tapa culata
	29	8000 91588	4	Rosetta di tenuta	Washer	Rondelle	Scheibe	Arandela
	30	8000 H6581	3	Vite	Screw	Vis	Schraube	Tornillo
	31	8000 A7039	1	Raccordo sfiato	Union	Raccord	Anschluss	Empalme
	32	8000 01199	1	Anello OR	O-Ring	Bague OR	O Ring	Anillo OR

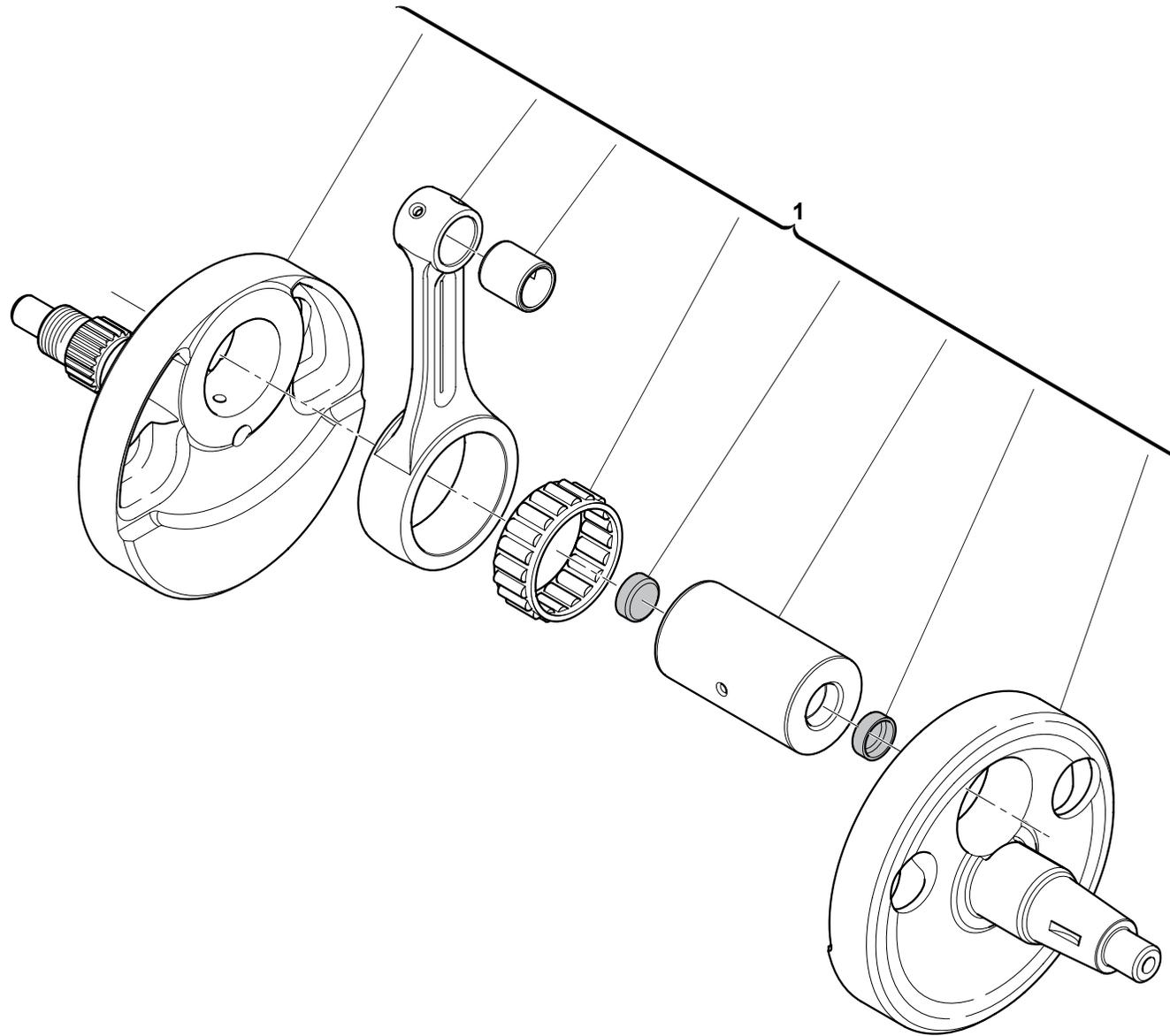





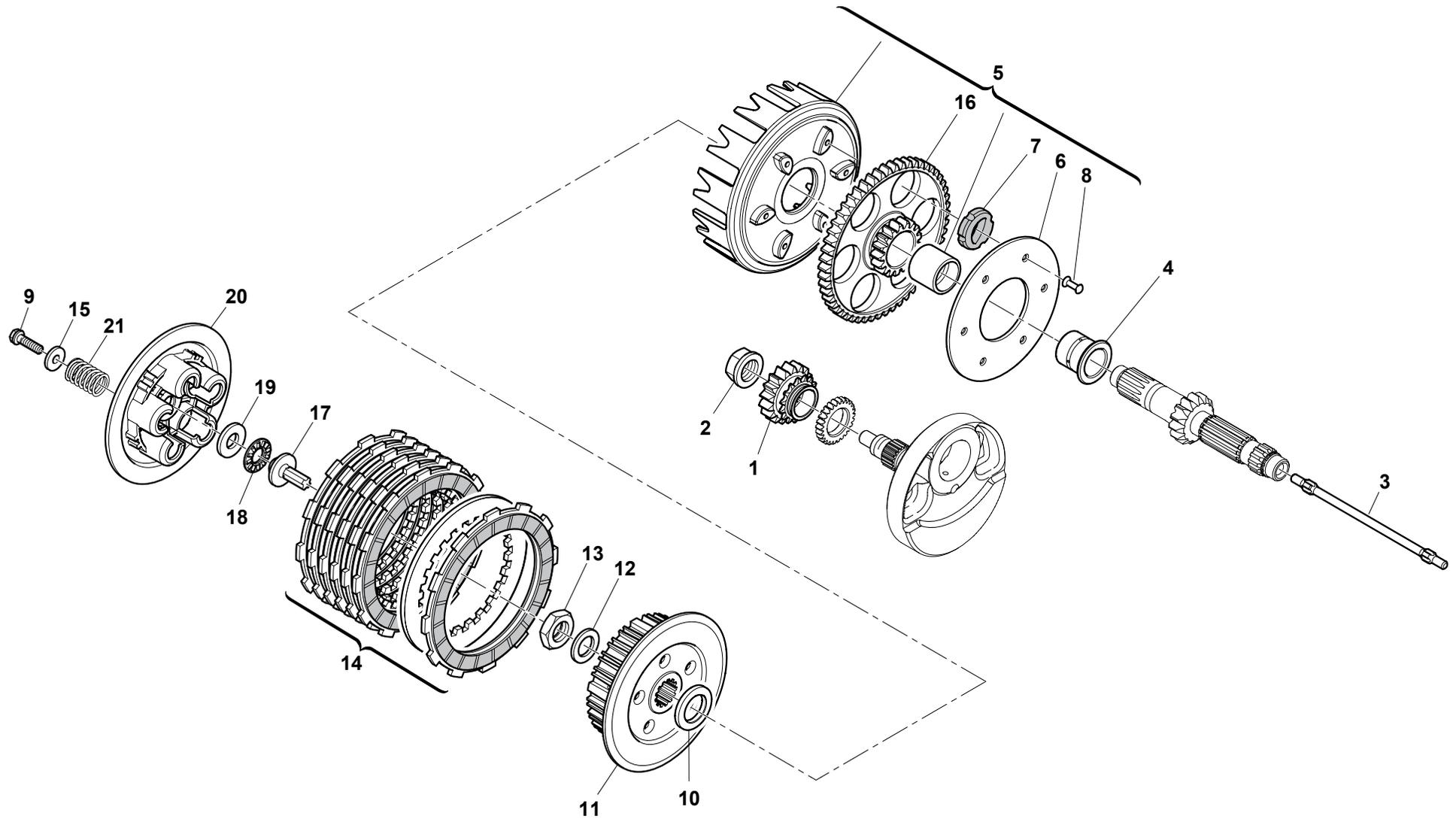

TRASMISSIONE PRIMARIA, FRIZIONE - PRIMARY DRIVE, CLUTCH  
TRANSMISSION PRIMAIRE, EMBRAYAGE  
PRIMÄRÜBERSETZUNG, KUPPLUNG - TRANSMISION PRIMARIA, EMBRAGUE



Note Notes Notes Marke Notas	Pos. No. N. Index Pos.	N. Cod. Code No. Nr. Code Code Nr N. Cod.	Q.tà Q.ty Q.te M.ge C.ad	DENOMINAZIONE	NAME	DESIGNATION	BESHREIBUNG	DENOMINACION
	1	8000 A6607	1	Ingranaggio conduttore (Z=17)	Driving gear (Z=17)	Engrimage conducteur (Z=17)	Antriebszahnrad (Z=17)	Engranaje conductor (Z=17)
	2	8000 A6617	1	Dado	Nut	Ecrou	Mutter	Tuerca
	3	8000 A7045	1	Astina disinnesto frizione	Control rod.	Coulisseau	Steuerstange	Varilla
	4	8539328	1	Bussola	Bushing	Douille	Buchse	Buje
	5	8000 H7839	1	Ingr. condotto completo (Z=54)	Driving gear assy (Z=54)	Engrimage compl. (Z=54)	Zahnrad komplett (Z=54)	Engranaje completo (Z=54)
	6	8A00 65844	1	Disco ritegno	Retainer disc	Reténer disque	Klemmplatte	Disco retendor
	7	8B00 31378	6	Parastrappi	Dampers	Parechocs	Dampfer	Amortiguadores
	8	63N016349	6	Rivetto	Rivet	Rivet	Niet	Remache
	9	Z000 62728	5	Vite	Screw	Vis	Schraube	Tornillo
	10	8000 A7034	1	Rosetta	Washer	Rondelle	Scheibe	Arandela
	11	8000 A7033	1	Mozzo portadischi	Hub disc carrier	Moyeuporte disque	Nabe	Cubo portadisco
	12	8000 29089	1	Rosetta	Washer	Rondelle	Scheibe	Arandela
	13	8A00 31386	1	Dado M16	Nut M16	Ecrou M16	Mutter M16	Tuerca M16
	14	8000 A7037	1	Ass. gruppo dischi frizione	Clutch disc group assy	Groupe disques embr. compl.	Kupplungs Scheibengruppe Kpl.	Grupo discos embr. compl.
	15	Z000 48814	5	Rosetta	Washer	Rondelle	Scheibe	Arandela
	16	8000 A6609	1	Ingranaggio condotto (Z=54)	Gear (Z=54)	Engrenage (Z=54)	Zahnrad (Z=54)	Engranaje (Z=54)
	17	8000 A7046	1	Perno comando frizione	Clutch control pin	Axe commande embrayage	Kupplungssteuerstift	Perno mando embrague
	18	8000 70550	1	Gabbia assiale a rulli	Needle bearing cage	Cage a aiguilles	Nadelkfig	Sombrerete de cojinete
	19	8000 70551	1	Ralla	Washer	Rondelle	Unterlegscheibe	Arandela
	20	8000 70467	1	Piatto spingidisco	Push disc plate	Pousser disque plaque	Stoben scheibe	Empujar disco
	21	8000 H7470	5	Molla per frizione	Clutch spring	Embrayage ressort	Kupplung feder	Embrague resorte

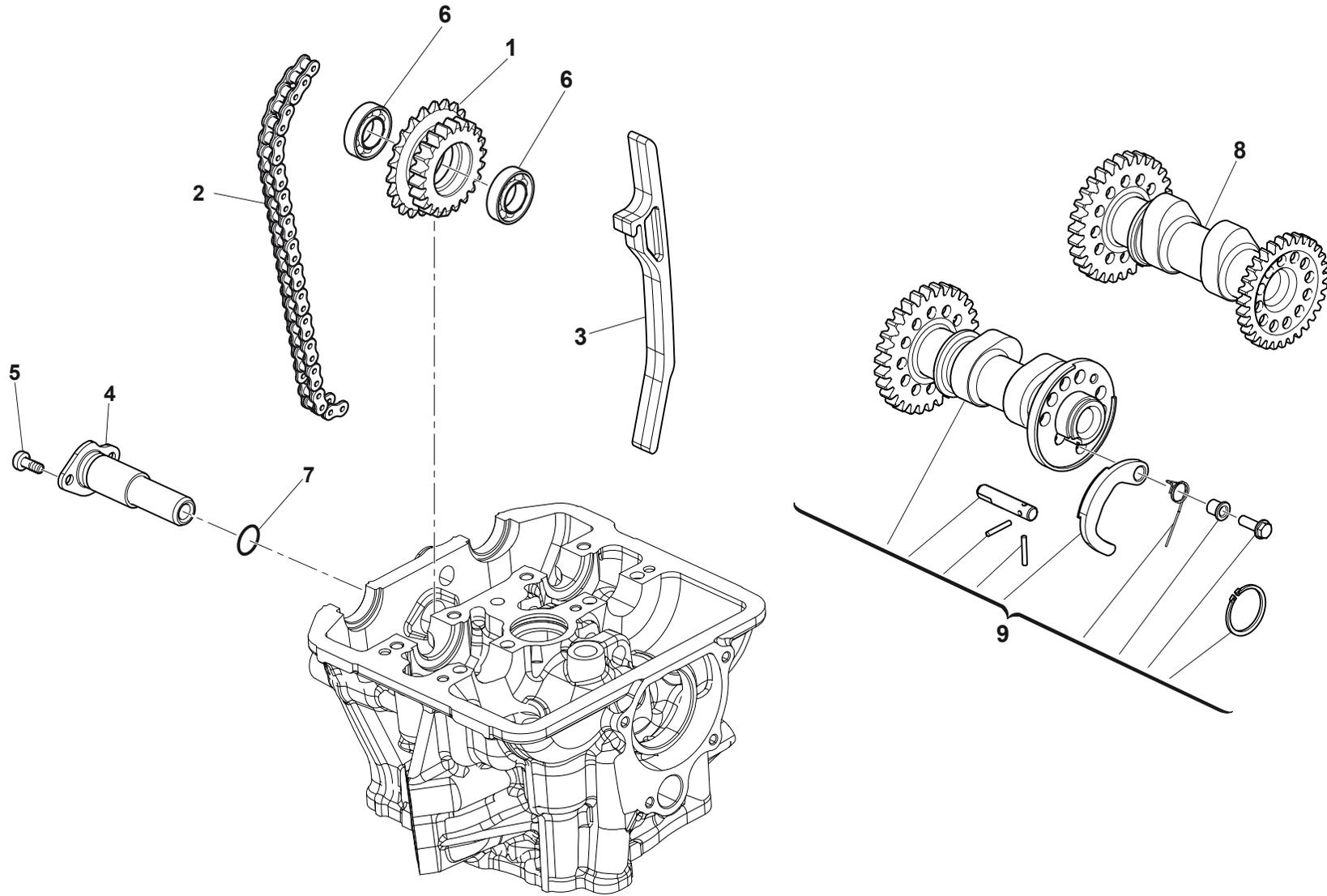



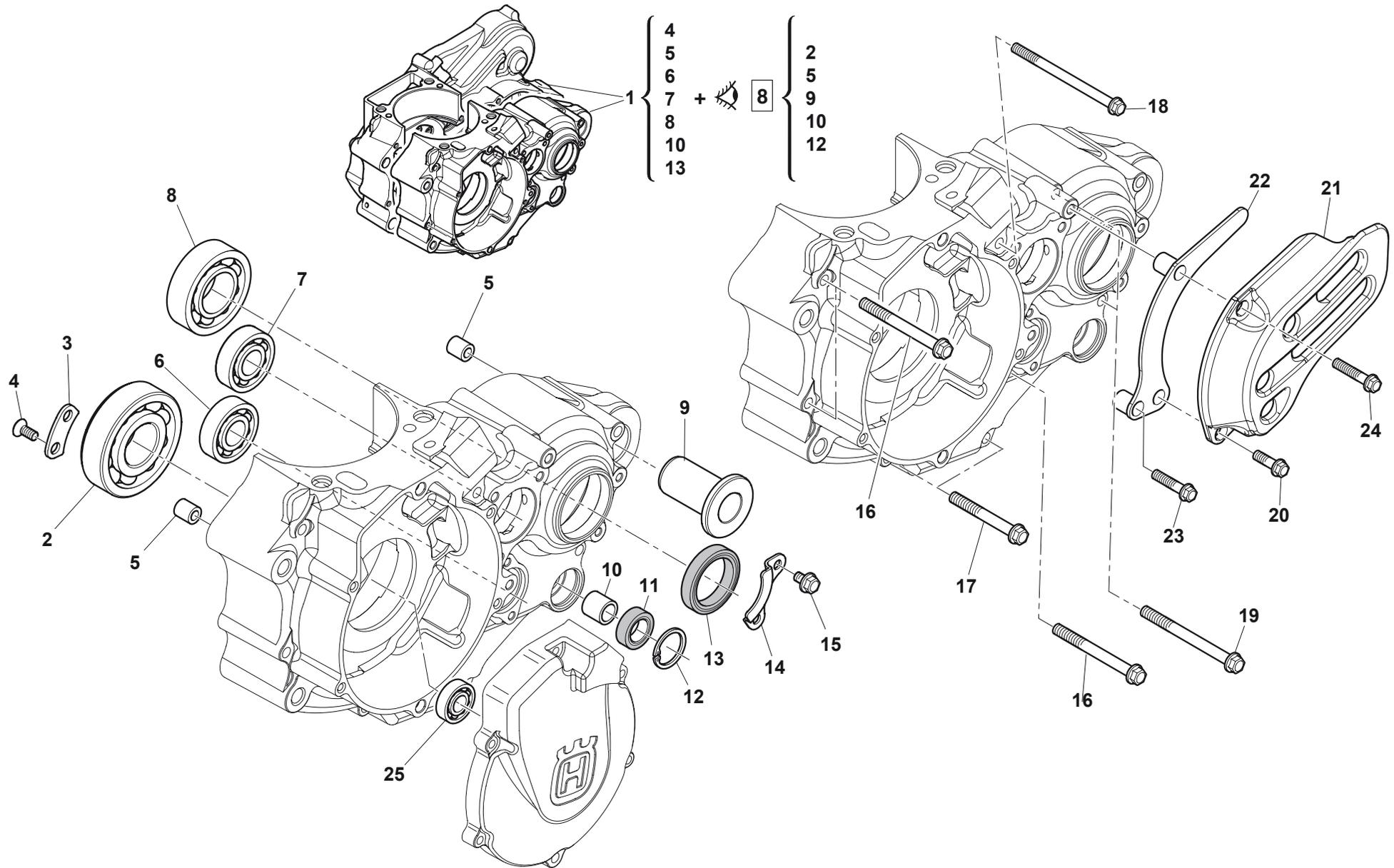

**TE-TXC-TC 250/2013**  
**TE-TXC 310/2013**

TAVOLA - DRAWING  
 TABLE - BILD - TABLA

**7**

**SEMICARTER SINISTRO - L.H. HALF CRANKCASE**  
**CARTER G. - GEHAUSEDECKEL L.**  
**BANCADA IZQ.**



Note Notes Notes Marke Notas	Pos. No. N. Index Pos.	N. Cod. Code No. Nr. Code Code Nr N. Cod.	Q.tà Q.ty Q.te M.ge C.ad	DENOMINAZIONE	NAME	DESIGNATION	BESHREIBUNG	DENOMINACION
TCW	1	W000 W0829	1	Assieme carters accoppiati	Crankcase assy	Carter compl.	Kurberlgehaue komplett	Carter motor completi
KB	1	W000 W0830	1	Assieme carters accoppiati	Crankcase assy	Carter compl.	Kurberlgehaue komplett	Carter motor completi
	2	8000 A6970	1	Cuscinetto	Bearing	Roulement	Kugellager	Cojinete
	3	8539125	2	Piastrina ritegno cuscinetto	Plate cover	Plaque	Platte	Placa
	4	8538995	4	Vite	Screw	Vis	Schraube	Tornillo
	5	1610 77703	2	Bussola	Bushing	Douille	Buchse	Manguito
	6	8000 A6975	1	Cuscinetto	Bearing	Roulement	Kugellager	Cojinete
	7	8000 A6972	1	Cuscinetto	Bearing	Roulement	Kugellager	Cojinete
	8	8000 H4964	1	Cuscinetto	Bearing	Roulement	Kugellager	Cojinete
	9	8000 73500	1	Bussola	Bushing	Douille	Buchse	Manguito
	10	8A00 65847	1	Boccola	Bushing	Douille	Buchse	Buje
	11	8000 28855	1	Anello	Ring	Anneau	Ring	Anillo
	12	66N0 21258	1	Anello elastico	Snap ring	Circlip	Sicherungspring	Circlip interior
	13	8000 A6981	1	Anello di tenuta	Seal ring	Bague d'etancheite	Dichtring	Anillo de retención
	14	8000 A6982	1	Piastrina ritegno paraolio	Plate cover	Plaque	Platte	Placa
	15	ZD00 67997	2	Vite	Screw	Vis	Schraube	Tornillo
	16	ZD00 67545	3	Vite	Screw	Vis	Schraube	Tornillo
	17	ZB00 67545	2	Vite	Screw	Vis	Schraube	Tornillo
	18	ZU00 67545	1	Vite	Screw	Vis	Schraube	Tornillo
	19	ZG00 67545	3	Vite	Screw	Vis	Schraube	Tornillo
	20	Z000 62725	1	Vite	Screw	Vis	Schraube	Tornillo
	21	80A0 66973	1	Coperchio pignone catena	Cover	Couvercle	Deckel	Tapa
	22	8000 H1016	1	Piastra guidacatena	Plate chain	Plaquette chaine	Platte	Plaquita cadene
	23	ZPA0 67545	1	Vite	Screw	Vis	Schraube	Tornillo
	24	Z000 62730	1	Vite	Screw	Vis	Schraube	Tornillo
WBKT	25	8000 28959	1	Cuscinetto	Bearing	Roulement	Kugellager	Cojinete

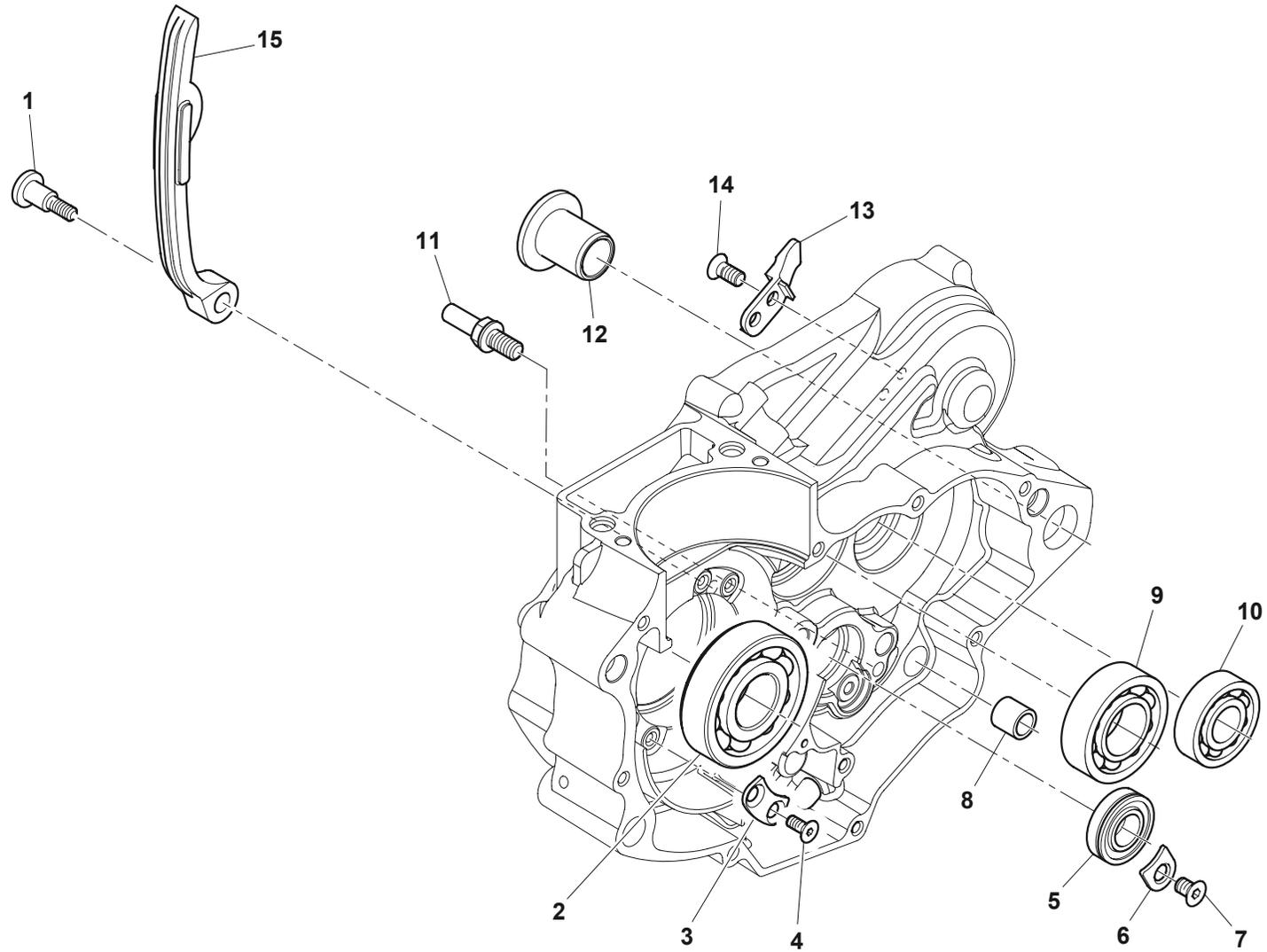





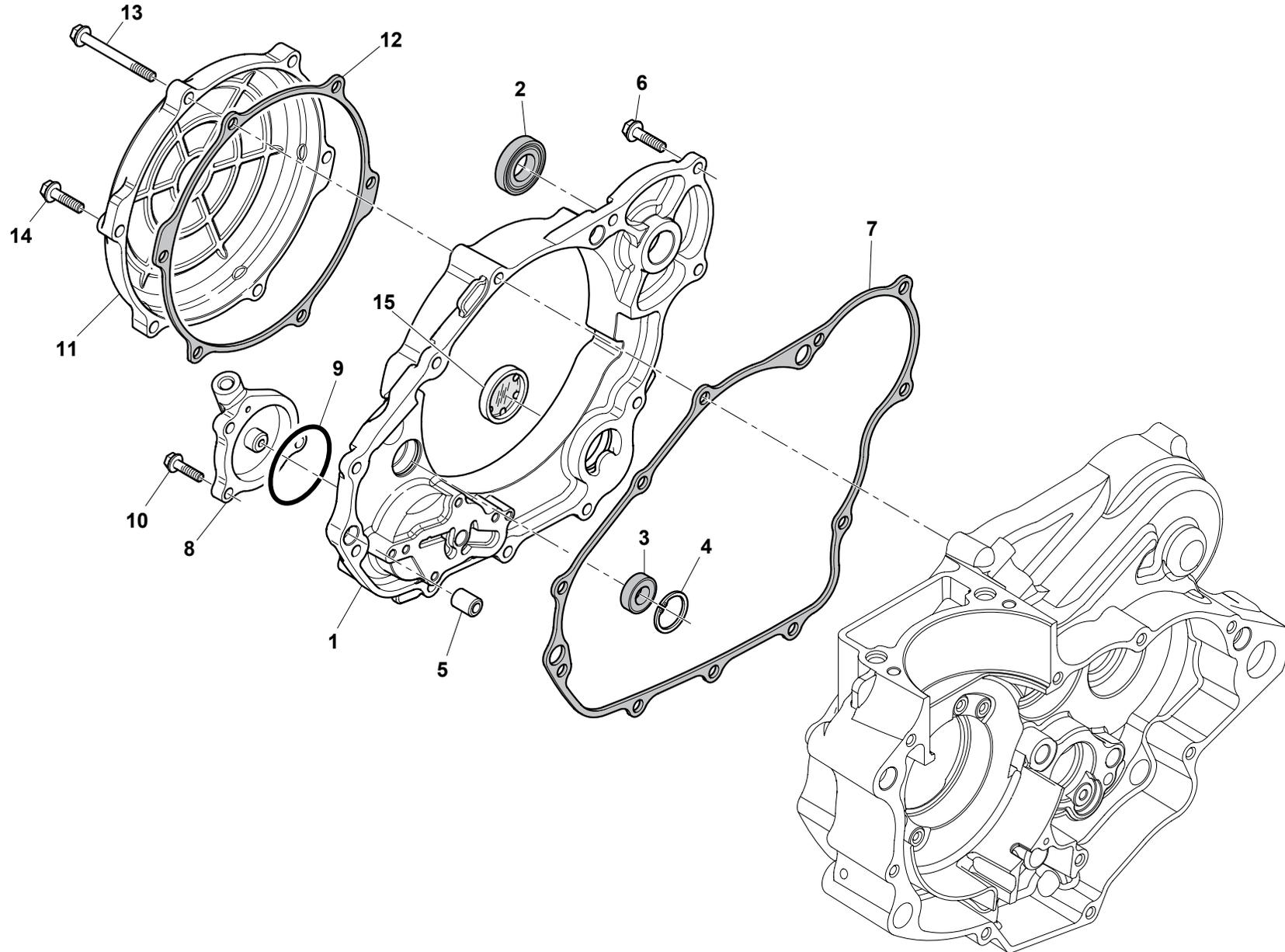



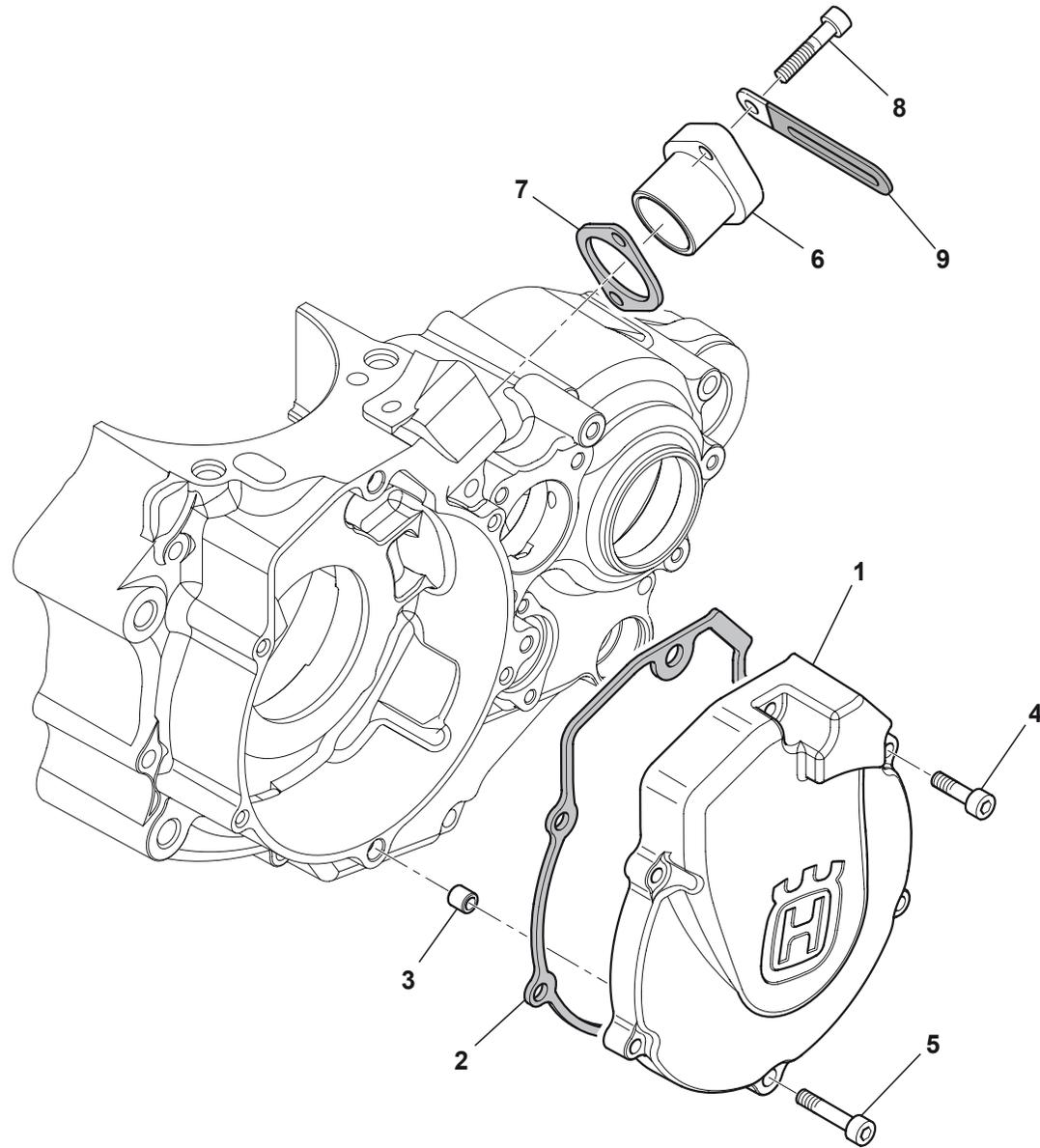



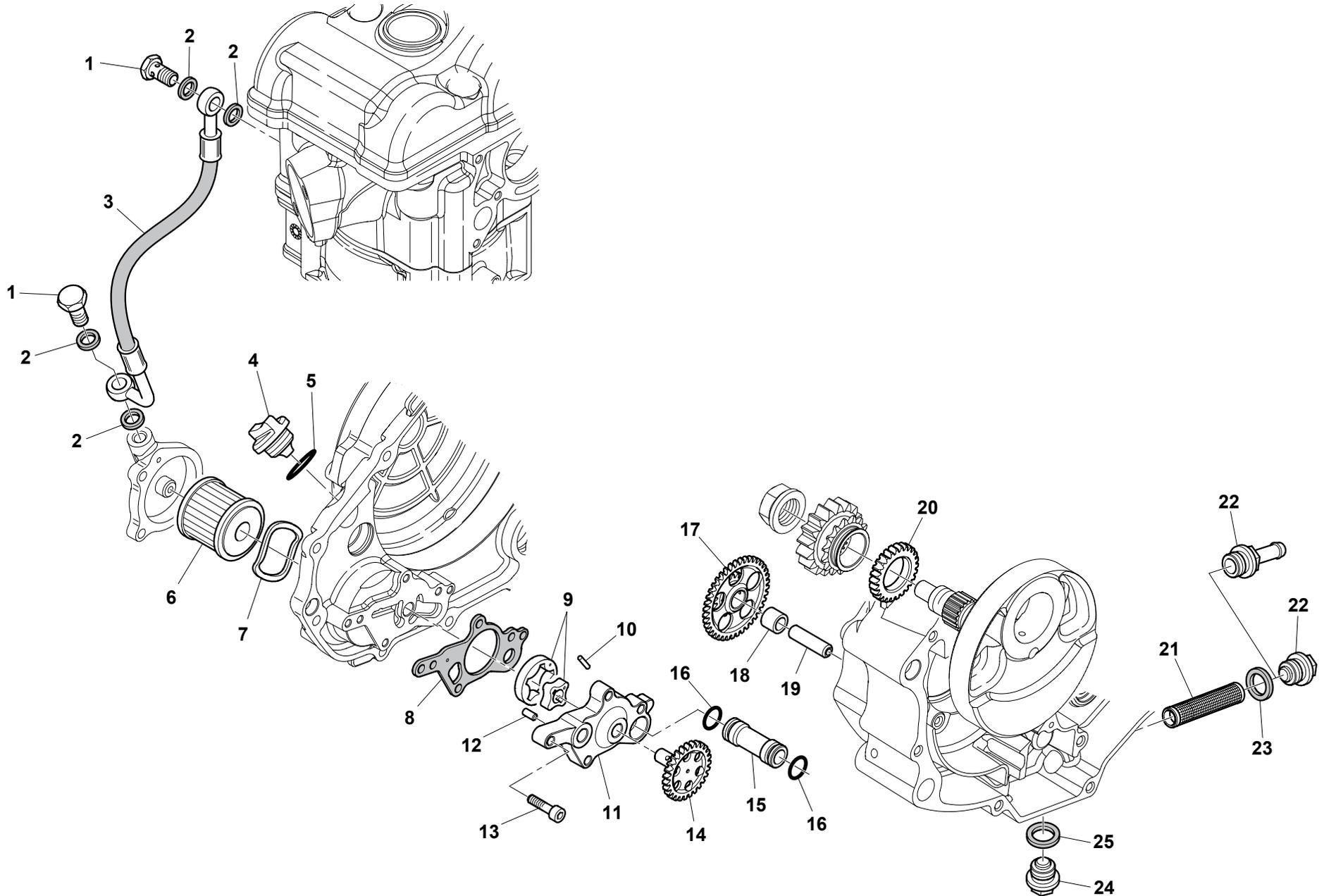

LUBRIFICAZIONE - OIL PUMP  
PUMPE HUILE - MOTORSCHMIERUNG  
LUBRICACION

Note Notes Notes Marke Notas	Pos. No. N. Index Pos.	N. Cod. Code No. Nr. Code Code Nr N. Cod.	Q.tà Q.ty Q.te M.ge C.ad	DENOMINAZIONE	NAME	DESIGNATION	BESHREIBUNG	DENOMINACION
	1	8000 A7023	2	Vite	Screw	Vis	Schraube	Tornillo
	2	8000 45194	4	Rosetta di tenuta	Washer	Rondelle	Scheibe	Arandela
BK	3	8538637	1	Tubo mandata olio	Oil pipe	Tuyauterie d'huile	Oelrohr	Tubo aceite
TWC	3	8A00 A7022	1	Tubo mandata olio	Oil pipe	Tuyauterie d'huile	Oelrohr	Tubo aceite
	4	8000 36786	1	Tappo carico olio	Oil filling cap	Bouchon rempl. huile	Öleinfüllstöpsel	Tapón intruducción aceite
	5	8000 29171	1	Anello OR	O-Ring	Bague OR	O Ring	Anillo OR
	6	8000 A7019	1	Filtro olio a cartuccia	Oil filter element	Element filtrant huile	Filtereinsatz	Elemento de filtrado aceite
	7	8000 A7011	1	Rosetta	Washer	Rondelle	Scheibe	Arandela
	8	8000 A7061	1	Guarnizione	Gasket	Garniture	Dichtung	Junta
	9	8000 A7007	1	Rotor olio	Rotor assy.	Rotor compl.	Rotor kpl.	Rotor compl.
	10	6BNO A7474	1	Rullino	Roller	Aiguille	Rolle	Rodillo
	11	8000 A7009	1	Ass. corpo pompa	Body Pump	Corps de pompe	Pumpengehause	Cuerpo de bomba
	12	8000 A7012	2	Spina	Dowel	Plot	Zylinderst	Centraje
	13	60ND 02487	4	Vite	Screw	Vis	Schraube	Tornillo
	14	8000 A7006	1	Albero pompa con ingranaggio	Pump shaft	Arbre pompe	Pumpenwelle	Eje bomba
	15	8000 A7017	1	Tubo olio	Oil pipe	Tuyauterie d'huile	Oelrohr	Tubo aceite
	16	8000 01199	2	Anello OR	O-Ring	Bague OR	O Ring	Anillo OR
	17	8000 A7014	1	Ingranaggio intermedio	Idler gear	Engrenage secondaire	Zwischenzahnrad	Engranaje secundario
	18	8000 31748	1	Boccola	Bushing	Douille	Buchse	Buje
	19	8000 A7016	1	Albero	Shaft	Arbre	Welle	Arbol
	20	8000 A7013	1	Ingranaggio conduttore	Driving gear	Engrenage conducteur	Antriebszahnrad	Engranaje conductor
WTC	21	8000 A7020	1	Filtro a rete	Filter	Filtre	Filter	Filtro
BK	21	8000 H4983	1	Filtro a rete	Filter	Filtre	Filter	Filtro
WTC	22	8000 A7021	1	Tappo scarico olio	Oil drain plug	Bouchon vidange huile	Stöpsel f. ölabblass	Tapón purga aceite
BK	22	8000 H5764	1	Raccordo	Union	Raccord	Anschluss	Empalme
	23	8000 47763	1	Rosetta	Washer	Rondelle	Scheibe	Arandela
	24	800073011	1	Vite magnetica scarico olio	Oil drain magnetic screw	Vis magnétique vidange huile	Schraube Ölabblass	Tornillo magnético purga aceite
	25	62N015678	1	Rosetta in alluminio	Aluminium washer	Rondelle aluminium	Scheibe Aluminium	Arandela en aluminio

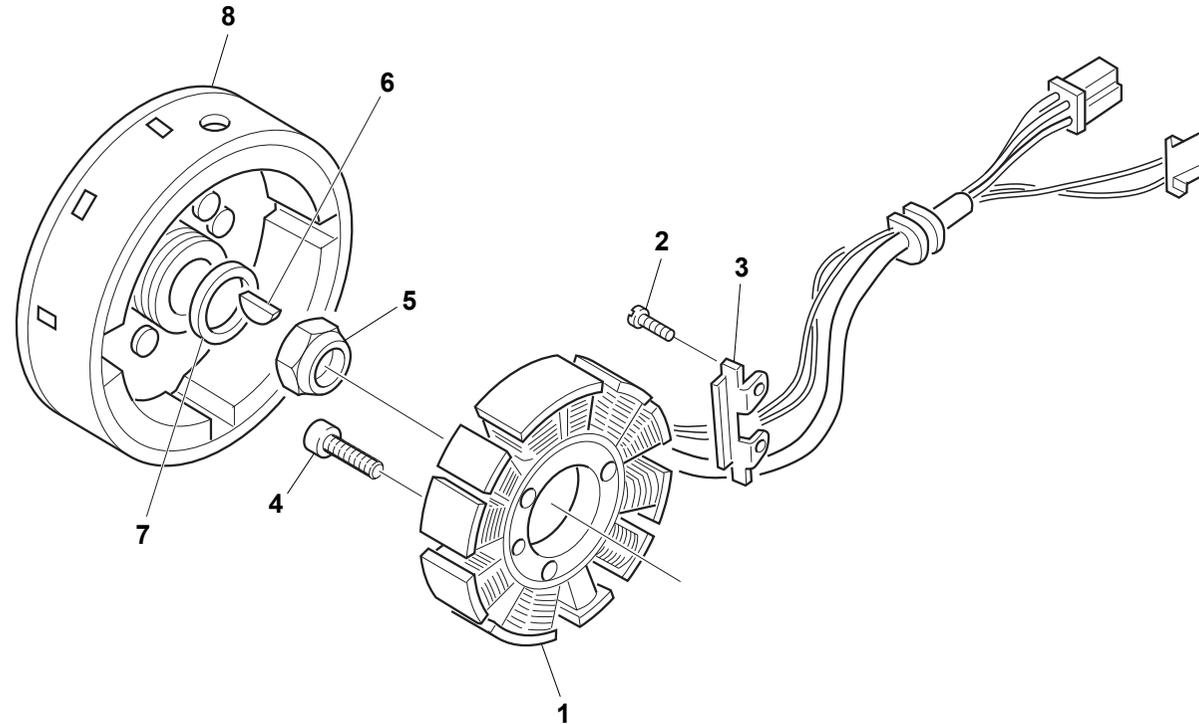





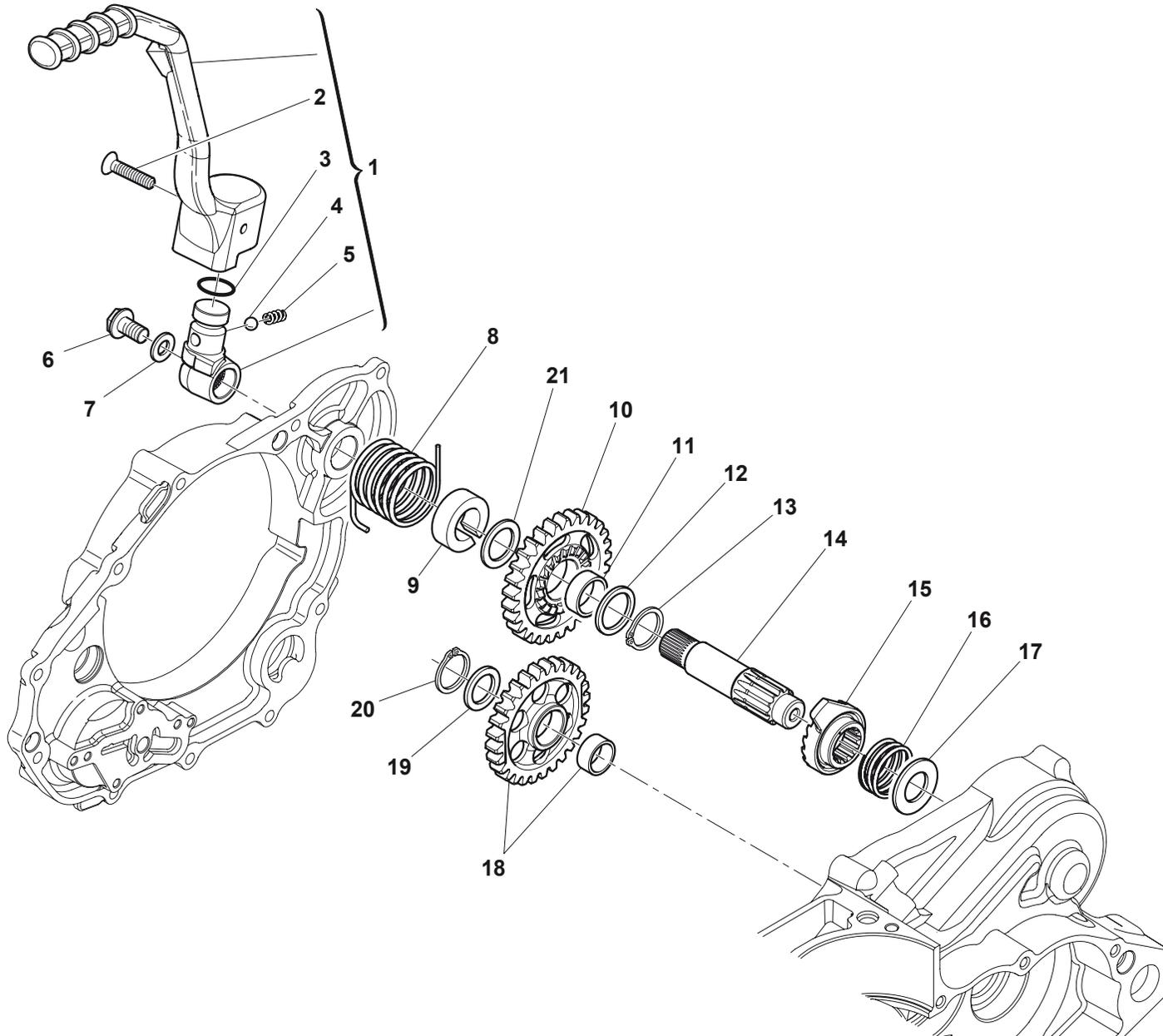

**AVVIAMENTO A PEDALE - KICK STARTER  
 DEMARRAGE À PÉDALE - KICK ANLASSER  
 ARRANQUE A PEDAL**
TAVOLA - DRAWING  
TABLE - BILD - TABLA

13

Note Notes Notes Marke Notas	Pos. No. Index Pos.	N. Cod. Code No. Nr. Code Code Nr N. Cod.	Q.tà Q.ty Q.te M.ge C.ad	DENOMINAZIONE	NAME	DESIGNATION	BESHREIBUNG	DENOMINACION
	1	8000 H2252	1	Ass. leva avviamento	Pedal assy	Pedale compl.	Pedal kpl.	Pedal compl.
	2	8000 38287	1	Vite	Screw	Vis	Schraube	Tornillo
	3	8000 36380	1	Anello OR	O-Ring	Bague OR	O Ring	Anillo OR
	4	6BN0 21507	1	Sfera 1/4"	Ball 1/4"	Bille 1/4"	Kugel 1/4"	Esfera 1/4"
	5	1611 08401	1	Molla	Spring	Ressort	Feder	Resorte
	6	Y000 60577	1	Vite	Screw	Vis	Schraube	Tornillo
	7	8000 99973	1	Rosetta	Washer	Rondelle	Scheibe	Arandela
	8	8000 A7083	1	Molla rich. leva avviamento	Spring	Ressort	Feder	Resorte
	9	8000 A7087	1	Distanziale per molla	Spacer	Entretoise	Distanzstück	Separador
	10	8000 A7080	1	Ingranaggio avviamento	Start gear	Engrainage demarrage	Zahnrad	Engranaje de arranque
	11	8000 A7081	1	Boccola	Bushing	Douille	Buchse	Buje
	12	8000 A7082	1	Rosetta di rasamento	Washer	Rondelle de butée	Ausgleichscheibe	Arandela de tope
	13	66N0 21208	1	Anello elastico	Snap ring	Circlip	Sprengring	Anillo elástico
	14	8000 H5023	1	Albero avviamento	Starter crank shaft	Arbre dedémarrage	Kickstarterwellw	Eje arranque
	15	8000 A7084	1	Cricchetto scorrevole	Sliding gear	Engrenage	Zahnrad	Engranaje
	16	8000 A5895	1	Molla	Spring	Ressort	Feder	Resorte
	17	8B00 13332	1	Rosetta	Washer	Rondelle	Scheibe	Arandela
	18	8000 A6565	1	Ass.ingranaggio di rinvio	Gear idler	Engrenage de renvoi	Vorgelegezahnrad	Engrenaje de reenvio
	19	8000 A7112	1	Rosetta (SP= 0,5 mm)	Washer (SP= 0,5 mm)	Rondelle (SP= 0,5 mm)	Scheibe (SP= 0,5 mm)	Arandela (SP= 0,5 mm)
	20	66N0 21206	1	Anello elastico	Split ring	Anneau ressort	Sprengring	Anillo elástico
	21	8C00 48590	1	Rosetta (SP= 0,6 mm)	Washer (SP= 0,6 mm)	Rondelle (SP= 0,6 mm)	Scheibe (SP= 0,6 mm)	Arandela (SP= 0,6 mm)

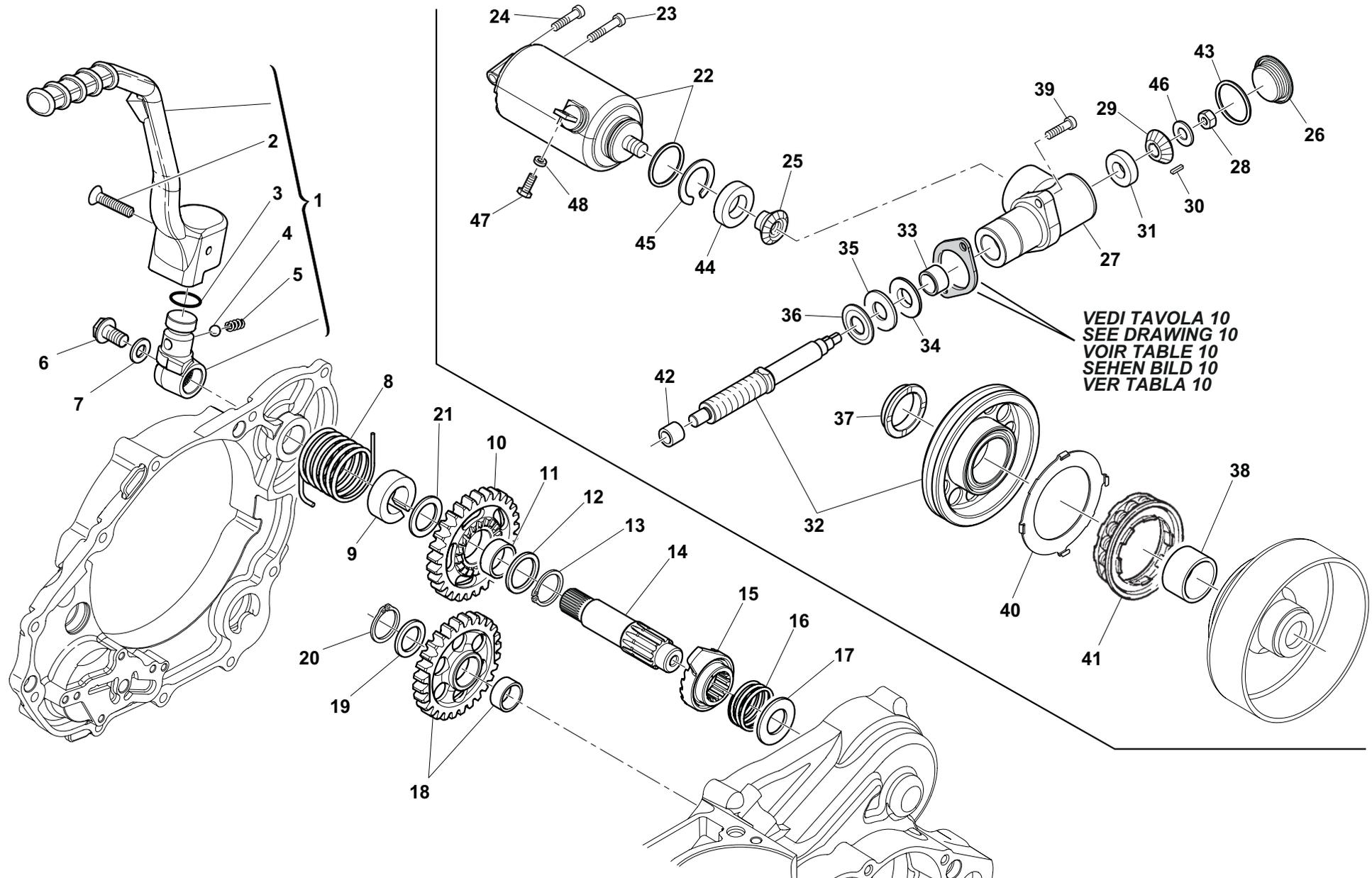

TE-TXC 250/2013  
TE-TXC 310/2013

TAVOLA - DRAWING  
TABLE - BILD - TABLA

13A

AVVIAMENTO ELETTRICO E A PEDALE - ELECTRIC STARTING AND KICK STARTER  
DEMARRAGE ELECTRIQUE ET À PÉDALE - ELEKTRISCHE ANLASSER UND KICK ANLASSER  
ARRANQUE ELECTRICO Y A PEDAL



Note Notes Notes Marke Notas	Pos. No. N. Index Pos.	N. Cod. Code No. Nr. Code Code Nr N. Cod.	Q.tà Q.ty M.ge C.ad	DENOMINAZIONE	NAME	DESIGNATION	BESHREIBUNG	DENOMINACION
	1	8000 H2252	1	Ass. leva avviamento	Pedal assy	Pedale compl.	Pedal kpl.	Pedal compl.
	2	8000 38287	1	Vite	Screw	Vis	Schraube	Tornillo
	3	8000 36380	1	Anello OR	O-Ring	Bague OR	O Ring	Anillo OR
	4	6BN0 21507	1	Sfera 1/4"	Ball 1/4"	Bille 1/4"	Kugel 1/4"	Esfera 1/4"
	5	1611 08401	1	Molla	Spring	Ressort	Feder	Resorte
	6	Y000 60577	1	Vite	Screw	Vis	Schraube	Tornillo
	7	8000 99973	1	Rosetta	Washer	Rondelle	Scheibe	Arandela
	8	8000 A7083	1	Molla rich. leva avviamento	Spring	Ressort	Feder	Resorte
	9	8000 A7087	1	Distanziale per molla	Spacer	Entretoise	Distanzstück	Separador
	10	8000 A7080	1	Ingranaggio avviamento	Start gear	Engrenage demarrage	Zahnrad	Engranaje de arranque
	11	8000 A7081	1	Boccola	Bushing	Douille	Buchse	Buje
	12	8000 A7082	1	Rosetta di rasamento	Washer	Rondelle de butée	Ausgleichscheibe	Arandela de tope
	13	66N0 21208	1	Anello elastico	Snap ring	Circlip	Sprengring	Anillo elástico
	14	8000 H5023	1	Albero avviamento	Starter crank shaft	Arbre dedémarrage	Kickstarterwellw	Eje arranque
	15	8000 A7084	1	Cricchetto scorrevole	Sliding gear	Engrenage	Zahnrad	Engranaje
	16	8000 A5895	1	Molla	Spring	Ressort	Feder	Resorte
	17	8B00 13332	1	Rosetta	Washer	Rondelle	Scheibe	Arandela
	18	8000 A6565	1	Ass.ingranaggio di rinvio	Gear idler	Engrenage de renvoi	Vorgelegezahnrad	Engrenaje de reenvio
	19	8000 A7112	1	Rosetta (SP= 0,5 mm)	Washer (SP= 0,5 mm)	Rondelle (SP= 0,5 mm)	Scheibe (SP= 0,5 mm)	Arandela (SP= 0,5 mm)
	20	66N0 21206	1	Anello elastico	Split ring	Anneau ressort	Sprengring	Anillo elástico
	21	8C00 48590	1	Rosetta (SP= 0,6 mm)	Washer (SP= 0,6 mm)	Rondelle (SP= 0,6 mm)	Scheibe (SP= 0,6 mm)	Arandela (SP= 0,6 mm)
	22	8000 A7059	1	Motorino avviamento	Start motor	Moteur démarrage	Elektr anlasser	Motor de arranque
	23	60ND 02489	1	Vite	Screw	Vis	Schraube	Tornillo
	24	60ND 02488	1	Vite	Screw	Vis	Schraube	Tornillo
	25	8000 A7060	1	Ingranaggio conduttore	Driving gear	Engrenage conducteur	Antriebszahnrad	Engranaje conductor
	26	8000 A7068	1	Tappo	Plug	Bouchon	Verschluss	Tapón
	27	8000 A7070	1	Corpo coppia conica	Crown wheel and pinion body	Corps couple conique	Getriebe korper	Cuerpo par de engranage cónicas
	28	61ND 15062	1	Dado	Nut	Ecrou	Mutter	Tuerca
	29	8000 A7064	1	Ingranaggio condotto	Gear	Engrenage	Zahnrad	Engranaje
	30	8000 A7065	1	Chiavetta	Woodruff key	Clé woodruff	Federkeil	Lengüeta
	31	8000 A7066	1	Cuscinetto	Bearing	Roulement	Kugellager	Cojinete
	32	8539725	1	Kit trasmissione avviamento	Starter transmission kit	Kit transmission dedémarrage	Chokesteuerung Satz	Kit transmisión starter
	33	8000 33718	1	Boccola	Bushing	Douille	Buchse	Buje

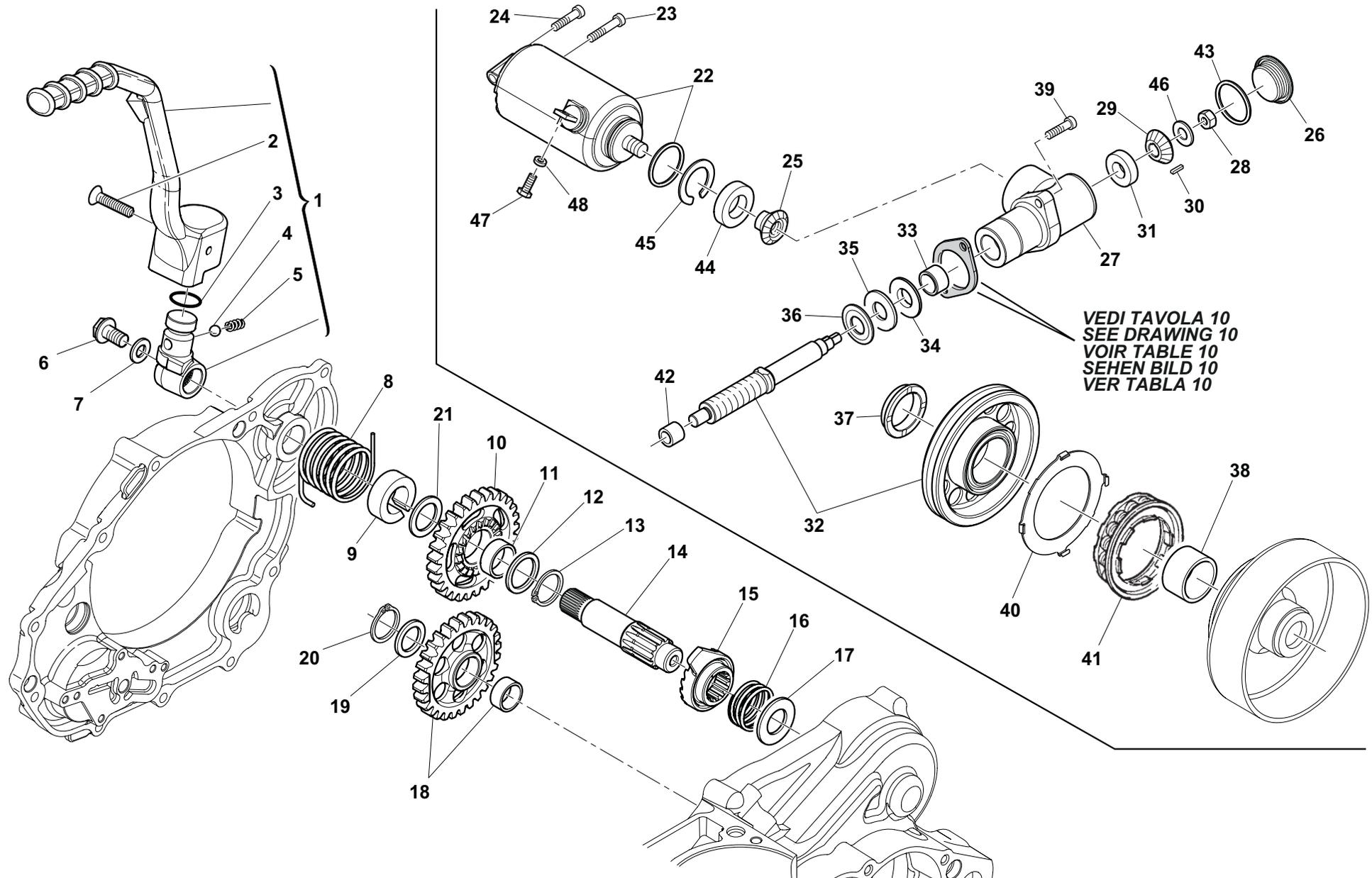



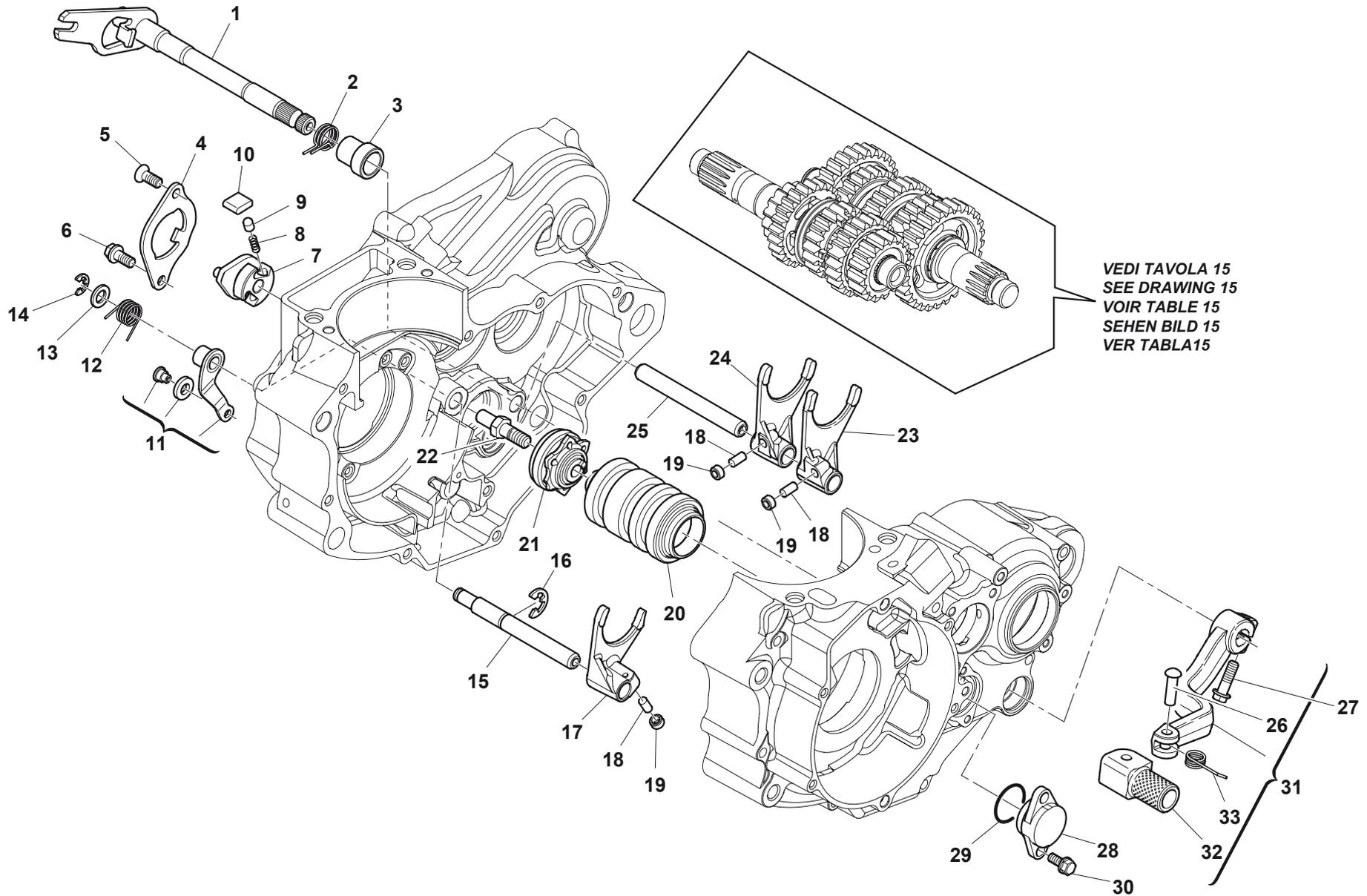

VEDI TAVOLA 15  
SEE DRAWING 15  
VOIR TABLE 15  
SEHEN BILD 15  
VER TABLA15

26  
27  
31  
32  
33



Note Notes Notes Marke Notas	Pos. No. Index Pos.	N. Cod. Code No. Nr. Code Code Nr N. Cod.	Q.tà Q.ty Q.te M.ge C.ad	DENOMINAZIONE	NAME	DESIGNATION	BESHREIBUNG	DENOMINACION
	1	8000 A6554	1	Assieme albero selettore	Shaft	Arbre	Welle	Arbol
	2	8000 A7329	1	Molla richiamo selettore	Spring	Ressort	Feder	Resorte
	3	8000 A7328	1	Bussola	Bushing	Douille	Buchse	Buje
	4	8000 A7318	1	Piastrina di fermo selettore	Stop ring	Bague d'arrêt	Haltering	Anillo de retención
	5	Y000 28327	1	Vite	Screw	Vis	Schraube	Tornillo
	6	Z000 62726	1	Vite	Screw	Vis	Schraube	Tornillo
	7	8000 A7314	1	Rocchetto superiore	Spool	Tiroir	Steuersheber	Carrette
	8	8000 71009	2	Molla per puntale	Spring	Ressort	Feder	Resorte
	9	8000 71008	2	Puntale per saltarello	Push rod	Embout	Stösselschaft	Puntal
	10	8000 A7315	2	Saltarello per rocchetto	Click	Cliquet	Strumhaken	Salt.
	11	8000 A7320	1	Saltarello fissamarce	Click	Cliquet	Strumhaken	Salt.
	12	8B00 A7325	1	Molla per saltarello	Spring	Ressort	Feder	Resorte
	13	8C00 34292	1	Rosetta	Washer	Rondelle	Scheibe	Arandela
	14	66N0 21310	1	Anello elastico	Snap ring	Circlip	Sprengring	Anillo elástico
	15	8000 A7312	1	Perno supp. forcella	Pin	Pivot	Bolzen	Perno
	16	66N0 21312	1	Anello elastico	Snap ring	Circlip	Sprengring	Anillo elástico
	17	8000 H4517	1	Forcella innesto 4°-5°	Yoke 4th-5th	Chape articulata 4ème- 5ème	Gelenkgabel 4°-5°	Yugo 4°-5°
	18	8000 A7310	3	Perno	Pin	Pivot	Bolzen	Perno
	19	8000 A7311	3	Rotella	Wheel	Galet	Rädchen	Ruedecilla
	20	8000 A7331	1	Albero comando forcelle	Shaft	Arbre	Welle	Arbol
	21	8000 A7305	1	Tamburo selettore marce	Drum	Tambour	Schraube	Tornillo
	22	8000 A7306	1	Vite fiss. tamburo selettore	Screw	Vis	Schraube	Tornillo
	23	8000 H4518	1	Forcella innesto 2°	Yoke 2nd	Chape articulata 2ème	Gelenkgabel 2°	Yugo 2°
	24	8000 H4519	1	Forcella innesto 1°-3°	Yoke 1st-3rd	Chape articulata 1ème-3ème	Gelenkgabel 1°-3°	Yugo 1°-3°
	25	8000 A7313	1	Perno supp. forcella	Pin	Pivot	Bolzen	Perno
	26	8000 99744	1	Ribattino	Rivet	Rivet	Niet	Remache
	27	Z000 62728	1	Vite	Screw	Vis	Schraube	Tornillo
	28	8000 H7439	1	Tappo	Plug	Bouchon	Verschluss	Tapón
	29	8A00 42700	1	Anello OR	O-Ring	Bague OR	O Ring	Anillo OR
	30	8000 66525	2	Vite	Screw	Vis	Schraube	Tornillo
	31	8000 A3488	1	Ass. leva comando cambio	Gearchange lever	Levier comm.vitesse	Schalthebe	Palanca del cambio
	32	8A00 A3485	1	Pedalino per leva comando cambio	Gearchange level pedal	Pedale	Pedal	Pedal
	33	8000 70216	1	Molla per pedalino comando cambio	Spring	Ressort	Feder	Resorte

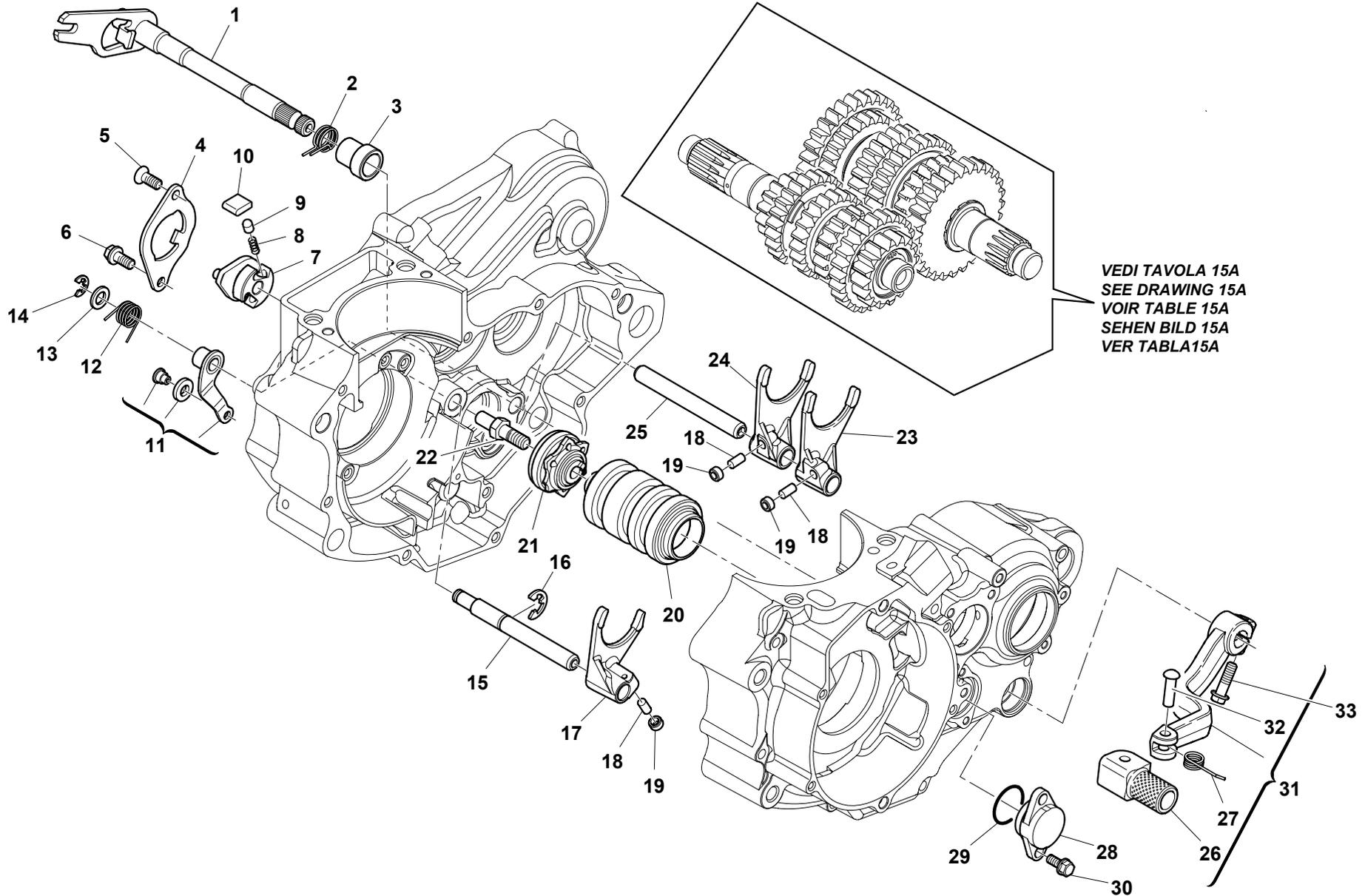

TE-TXC 250/2013  
TE-TXC 310/2013

TAVOLA - DRAWING  
TABLE - BILD - TABLA

14A

COMANDO CAMBIO - GEARSHIFT MECHANISM  
COMMANDE DE VITESSE - GANGSCHALTUNG  
MANDO CAMBIO

6 SPEED



Note Notes Notes Marke Notas	Pos. No. Index Pos.	N. Cod. Code No. Nr. Code Code Nr N. Cod.	Q.tà Q.ty Q.te M.ge C.ad	DENOMINAZIONE	NAME	DESIGNATION	BESHREIBUNG	DENOMINACION
	1	8000 A6554	1	Assieme albero selettore	Shaft	Arbre	Welle	Arbol
	2	8000 A7329	1	Molla richiamo selettore	Spring	Ressort	Feder	Resorte
	3	8000 A7328	1	Bussola	Bushing	Douille	Buchse	Buje
	4	8000 A7318	1	Piastrina di fermo selettore	Stop ring	Bague d'arrêt	Haltering	Anillo de retención
	5	Y000 28327	1	Vite	Screw	Vis	Schraube	Tornillo
	6	Z000 62726	1	Vite	Screw	Vis	Schraube	Tornillo
	7	8000 A7314	1	Rocchetto superiore	Spool	Tiroir	Steuersheber	Carrette
	8	8000 71009	2	Molla per puntale	Spring	Ressort	Feder	Resorte
	9	8000 71008	2	Puntale per saltarello	Push rod	Embout	Stösselschaft	Puntal
	10	8000 A7315	2	Saltarello per rocchetto	Click	Cliquet	Strumhaken	Salt.
	11	8000 A7320	1	Saltarello fissamarce	Click	Cliquet	Strumhaken	Salt.
	12	8B00 A7325	1	Molla per saltarello	Spring	Ressort	Feder	Resorte
	13	8C00 34292	1	Rosetta	Washer	Rondelle	Scheibe	Arandela
	14	66N0 21310	1	Anello elastico	Snap ring	Circlip	Sprengring	Anillo elástico
	15	8000 A7312	1	Perno supp. forcella	Pin	Pivot	Bolzen	Perno
	16	66N0 21312	1	Anello elastico	Snap ring	Circlip	Sprengring	Anillo elástico
	17	8000 H4514	1	Forcella innesto 5°-6°	Yoke 5th-6th	Chape articulata 5ème-6ème	Gelenkgabel 5°-6°	Yugo 5°-6°
	18	8000 A7310	3	Perno	Pin	Pivot	Bolzen	Perno
	19	8000 A7311	3	Rotella	Wheel	Galet	Rädchen	Ruedecilla
	20	8000 A7304	1	Albero comando forcelle	Shaft	Arbre	Welle	Arbol
	21	8000 A7305	1	Tamburo selettore marce	Drum	Tambour	Schraube	Tornillo
	22	8000 A7306	1	Vite fiss. tamburo selettore	Screw	Vis	Schraube	Tornillo
	23	8000 H4515	1	Forcella innesto 2°-3°	Yoke 2nd-3rd	Chape articulata 2ème-3ème	Gelenkgabel 2°-3°	Yugo 2°-3°
	24	8000 H4516	1	Forcella innesto 1°-4°	Yoke 1st-4th	Chape articulata 1ème-4ème	Gelenkgabel 1°-4°	Yugo 1°-4°
	25	8000 A7313	1	Perno supp. forcella	Pin	Pivot	Bolzen	Perno
	26	8A00 A3485	1	Pedalino per leva comando cambio	Gearchange level pedal	Pedale	Pedal	Pedal
	27	8000 70216	1	Molla per pedalino comando cambio	Spring	Ressort	Feder	Resorte
	28	8000 H7439	1	Tappo	Plug	Bouchon	Verschluss	Tapón
	29	8A00 42700	1	Anello OR	O-Ring	Bague OR	O Ring	Anillo OR
	30	Z000 67997	2	Vite	Screw	Vis	Schraube	Tornillo
	31	8000 A3488	1	Ass. leva comando cambio	Gearchange lever	Levier comm.vitesse	Schalthebe	Palanca del cambio
	32	8000 99744	1	Ribattino	Rivet	Rivet	Niet	Remache
	33	Z000 62728	1	Vite	Screw	Vis	Schraube	Tornillo



**CAMBIO VELOCITA' - GEARBOX**  
**BOITE VITESSES - ZAHNRADGETRIEBE**  
**CAJA CAMBIO**

# 5 SPEED



Note Notes Notes Marke Notas	Pos. No. N. Index Pos.	N. Cod. Code No. Nr. Code Code Nr N. Cod.	Q.tà Q.ty Q.te M.ge C.ad	DENOMINAZIONE	NAME	DESIGNATION	BESHREIBUNG	DENOMINACION
	1	8000 H4017	1	Ass.albero primario	Main shaft	Arbre primaire	Hauptwelle	Eje primario
	2	8538927	1	Coppia ingranaggi 1^	Set of matched 1^	Engrenages 1^	Stirnradpaar 1^	Copla engranaje 1^
	3	8538931	1	Coppia ingranaggi 5^	Set of matched 5^	Engrenages 5^	Stirnradpaar 5^	Copla engranaje 5^
	4	8000 A7099	2	Gabbietta a rullini	Rolls cage	Cage de rouleaux	Walzenkäfig	Jaula rodillos
	5	8000 A7100	1	Rosetta	Washer	Rondelle	Scheibe	Arandela
	6	8000 A7101	1	Anello elastico	Snap ring	Circlip	Sprengring	Anillo elástico
	7	8538929	1	Coppia ingranaggi 3^	Set of matched 3^	Engrenages 3^	Stirnradpaar 3^	Copla engranaje 3^
	8	66N0 21326	1	Anello elastico	Snap ring	Circlip	Sprengring	Anillo elástico
	9	8000 A7116	1	Rosetta scanalata	Washer	Rondelle	Scheibe	Arandela
	10	8538930	1	Coppia ingranaggi 4^	Set of matched 4^	Engrenages 4^	Stirnradpaar 4^	Copla engranaje 4^
	11	8538928	1	Coppia ingranaggi 2^	Set of matched 2^	Engrenages 2^	Stirnradpaar 2^	Copla engranaje 2^
	12	66N0 21247	1	Anello elastico	Split ring	Anneau ressort	Sprengring	Anillo elástico
	13	8000 H4016	1	Ass. albero secondario	Secondary shaft assy	Arbre secondaire	Neben welle	Arbol secundario
	14	8000 A7295	1	Albero secondario	Secondary shaft	Arbre secondaire	Neben welle	Arbol secundario
STANDARD	15	8A00 A7126	1	Pignone uscita cambio (Z=13)	Pinion (Z=13)	Pignon (Z=13)	Ritzel (Z=13)	Piñón (Z=13)
OPTIONAL	15	8000 A7126	1	Pignone uscita cambio (Z=12)	Pinion (Z=12)	Pignon (Z=12)	Ritzel (Z=12)	Piñón (Z=12)
	16A	8000 A7348	1	Bussola	Bushing	Douille	Buchse	Buje
	16	8A00 A7348	1	Bussola	Bushing	Douille	Buchse	Buje
	17	8000 A7116	2	Rosetta scanalata	Washer	Rondelle	Scheibe	Arandela
	18	8000 A7100	1	Rosetta	Washer	Rondelle	Scheibe	Arandela
	19	66N0 21326	3	Anello elastico	Snap ring	Circlip	Sprengring	Anillo elástico
	20	8000 A7129	1	Dado	Nut	Ecrou	Mutter	Tuerca
	21	8000 A7125	1	Distanziale	Spacer	Entretoise	Distanzstück	Separador
	22	8000 A7128	1	Rosetta di sicurezza	Washer	Rondelle	Scheibe	Arandela
A*	23	8000 A7112	1	Rosetta (SP= 0,5 mm)	Washer (SP= 0,5 mm)	Rondelle (SP= 0,5 mm)	Scheibe (SP= 0,5 mm)	Arandela (SP= 0,5 mm)
	23	8A00 A7112	1	Rosetta (SP= 0,6 mm)	Washer (SP= 0,6 mm)	Rondelle (SP= 0,6 mm)	Scheibe (SP= 0,6 mm)	Arandela (SP= 0,6 mm)
	23	8A00 A7348	1	Bussola	Bushing	Douille	Buchse	Buje
	24	8000 A6597	1	Gabbietta a rullini	Rolls cage	Cage de rouleaux	Walzenkäfig	Jaula rodillos
*				Solo per lato esterno	Only for external side	Seulement pour extérieur large	Nur für außen seite	Solo por lado exterior

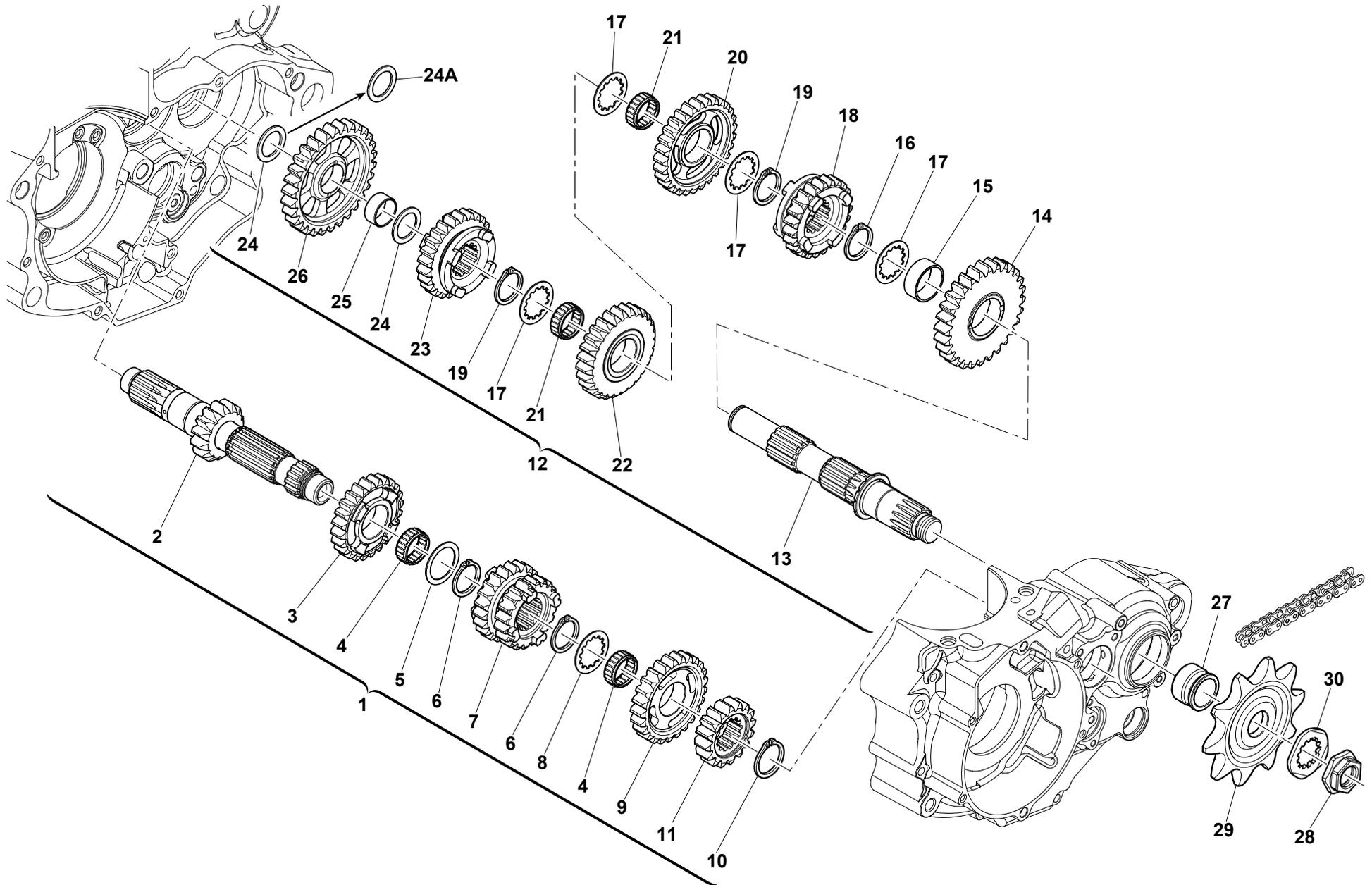

TE-TXC 250/2013  
TE-TXC 310/2013

TAVOLA - DRAWING  
TABLE - BILD - TABLA

15A

CAMBIO VELOCITA' - GEARBOX  
BOITE VITESSES - ZAHNRADGETRIEBE  
CAJA CAMBIO

6 SPEED



Note Notes Notes Marke Notas	Pos. No. N. Index Pos.	N. Cod. Code No. Nr. Code Code Nr N. Cod.	Q.tà Q.ty Q.te M.ge C.ad	DENOMINAZIONE	NAME	DESIGNATION	BESHREIBUNG	DENOMINACION
	1	8000 A7107	1	Ass.albero primario	Main shaft	Arbre primaire	Hauptwelle	Eje primario
	2	8000 A6949	1	Albero primario (Z=14)	Main shaft (Z=14)	Arbre primaire (Z=14)	Hauptwelle (Z=14)	Eje primario (Z=14)
	3	8000 A7098	1	Ingranaggio 5° sul primario (Z=24)	Gear 5th (Z=24)	Engrenage 5ème (Z=24)	Zahnrad 5° (Z=24)	Engranaje 5° (Z=24)
	4	8000 A7099	2	Gabbietta a rullini	Rolls cage	Cage de rouleaux	Walzenkäfig	Jaula rodillos
	5	8000 A7100	1	Rosetta	Washer	Rondelle	Scheibe	Arandela
	6	66N0 21326	1	Anello elastico	Snap ring	Circlip	Sprengring	Anillo elástico
	7	8000 A7102	1	Ingr. 3°- 4° sul primario (Z=20)-(Z=22)	Main shaft 3rd -4th gear (Z=20)-(Z=22)	Engr. 3ème-4ème vitesse arbre prim. (Z=20)-(Z=22)	Zahnrad F.3°- 4° Geschw. Antriebsw. (Z=20)-(Z=22)	Engr. 3°-4° vel. eje primario (Z=20)-(Z=22)
	8	8000 A7116	1	Rosetta scanalata	Washer	Rondelle	Scheibe	Arandela
	9	8000 A7104	1	Ingranaggio 6° sul primario (Z=26)	Main shaft 6th gear (Z=26)	Engrenage 6ème vitesse arbre prim. (Z=26)	Zahnrad F.6. Geschw. Antriebsw. (Z=26)	Engranaje 6° velocidad eje primario (Z=26)
	10	66N0 21247	1	Anello elastico	Split ring	Anneau ressort	Sprengring	Anillo elástico
	11	8000 A7297	1	Ingranaggio 2° sul primario (Z=16)	Main shaft 2nd gear (Z=16)	Engrenage 2ème vitesse arbre prim. (Z=16)	Zahnrad F.2. Geschw. Antriebsw. (Z=16)	Engranaje 2° velocidad eje primario (Z=16)
	12	8000 A6349	1	Ass. albero secondario	Secondary shaft assy	Arbre secondaire	Neben welle	Arbol secundario
	13	8000 A7109	1	Albero secondario	Secondary shaft	Arbre secondaire	Neben welle	Arbol secundario
	14	8000 A7113	1	Ingranaggio 2° sul secondario (Z=28)	Secondary shaft 2nd gear (Z=28)	Engrenage 2ème vitesse arbre secon.(Z=28)	Zahnrad f.2. Geschw. Vorgelegew (Z=28)	Engranaje 2° velocidad Eje second.(Z=28)
	15	8000 A6961	1	Bussola	Bushing	Douille	Buchse	Buje
	16	66N0 21326	1	Anello elastico	Snap ring	Circlip	Sprengring	Anillo elástico
	17	8000 A7116	5	Rosetta scanalata	Washer	Rondelle	Scheibe	Arandela
	18	8000 A7122	1	Ingranaggio 6° sul secondario (Z=23)	Secondary shaft 6th gear (Z=23)	Engrenage 6ème vitesse arbre secon.(Z=23)	Zahnrad f.6. Geschw. Vorgelegew (Z=23)	Engranaje 6° velocidad Eje second.(Z=23)
	19	8000 A7101	2	Anello elastico	Snap ring	Circlip	Sprengring	Anillo elástico
	20	8000 A7115	1	Ingranaggio 3° sul secondario (Z=29)	Secondary shaft 3rd gear (Z=29)	Engrenage 3ème vitesse arbre secon.(Z=29)	Zahnrad f.3. Geschw. Vorgelegew (Z=29)	Engranaje 3° velocidad Eje second.(Z=29)
	21	8000 A7099	2	Gabbietta a rullini	Rolls cage	Cage de rouleaux	Walzenkäfig	Jaula rodillos
	22	8000 A7118	1	Ingranaggio 4° sul secondario (Z=27)	Secondary shaft 4th gear (Z=27)	Engrenage 4ème vitesse arbre secon.(Z=27)	Zahnrad f.4. Geschw. Vorgelegew (Z=27)	Engranaje 4° velocidad Eje second.(Z=27)
	23	8000 A7114	1	Ingranaggio 5° sul secondario (Z=25)	Secondary shaft 5th gear (Z=25)	Engrenage 5ème vitesse arbre secon.(Z=25)	Zahnrad f.5. Geschw. Vorgelegew (Z=25)	Engranaje 5° velocidad Eje second.(Z=25)
A*	24A	8000 A7112	1	Rosetta (SP= 0,5 mm)	Washer (SP= 0,5 mm)	Rondelle (SP= 0,5 mm)	Scheibe (SP= 0,5 mm)	Arandela (SP= 0,5 mm)
	24	8A00 A7112	2	Rosetta (SP= 0,6 mm)	Washer (SP= 0,6 mm)	Rondelle (SP= 0,6 mm)	Scheibe (SP= 0,6 mm)	Arandela (SP= 0,6 mm)
	25	8000 A7111	1	Bussola	Bushing	Douille	Buchse	Buje
	26	8000 A6946	1	Ingranaggio 1° sul secondario (Z=28)	Secondary shaft 1st gear (Z=28)	Engrenage 1ère vitesse arbre secon. (Z=28)	Zahnrad 1. Geschw. Vorgelegew (Z=28)	Engranaje 1° velocidad Eje second. (Z=28)
	27	8000 A7125	1	Distanziale	Spacer	Entretoise	Distanzstück	Separador
	28	8000 A7129	1	Dado	Nut	Ecrou	Mutter	Tuerca
STANDARD	29	8A00 A7126	1	Pignone uscita cambio (Z=13)	Pinion (Z=13)	Pignon (Z=13)	Ritzel (Z=13)	Piñón (Z=13)
OPTIONAL	29	8000 A7126	1	Pignone uscita cambio (Z=12)	Pinion (Z=12)	Pignon (Z=12)	Ritzel (Z=12)	Piñón (Z=12)
	30	8000 A7128	1	Rosetta di sicurezza	Washer	Rondelle	Scheibe	Arandela
*				Solo per lato esterno	Only for external side	Seulement pour extérieur large	Nur für außen seite	Solo por lado exterior

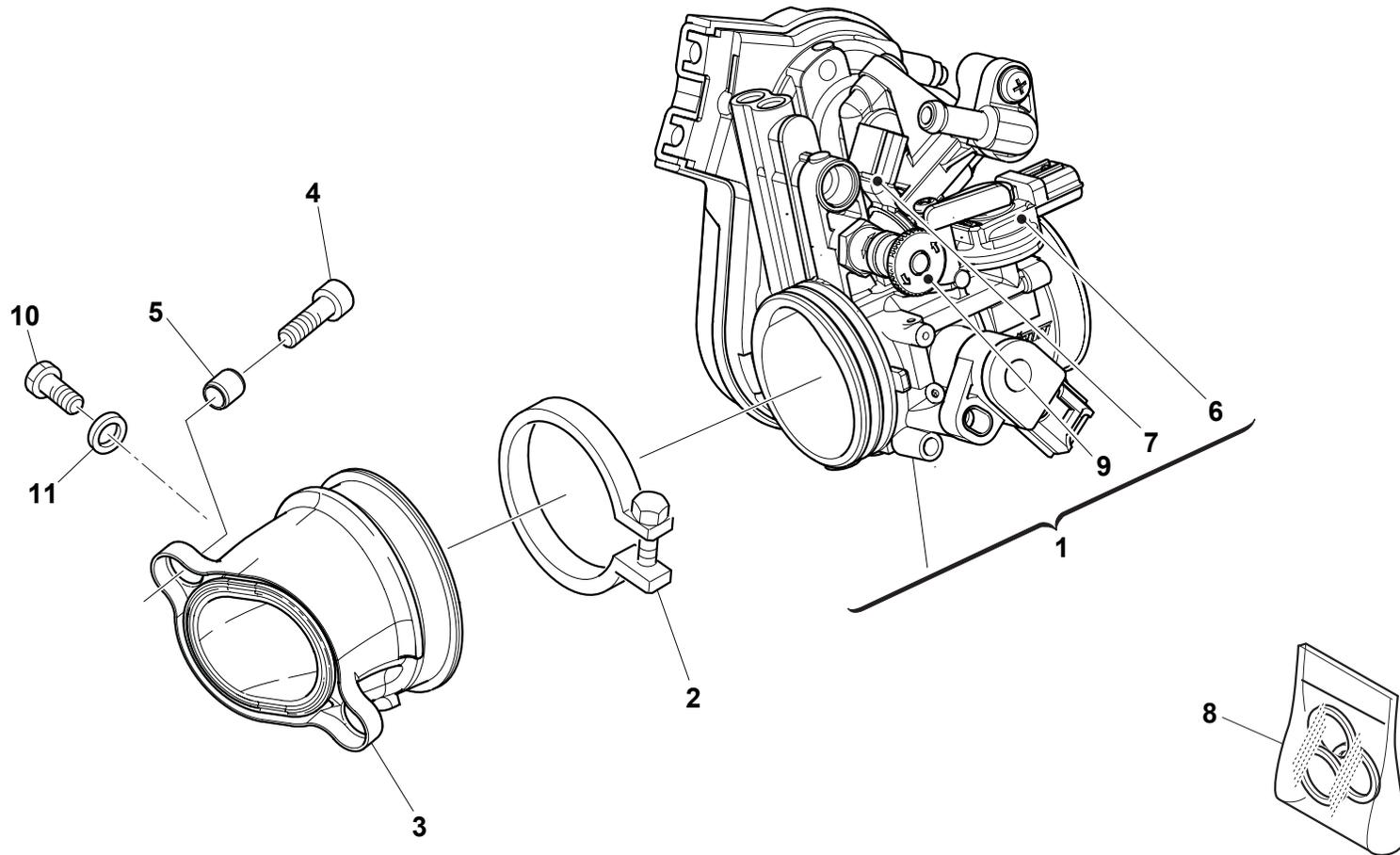





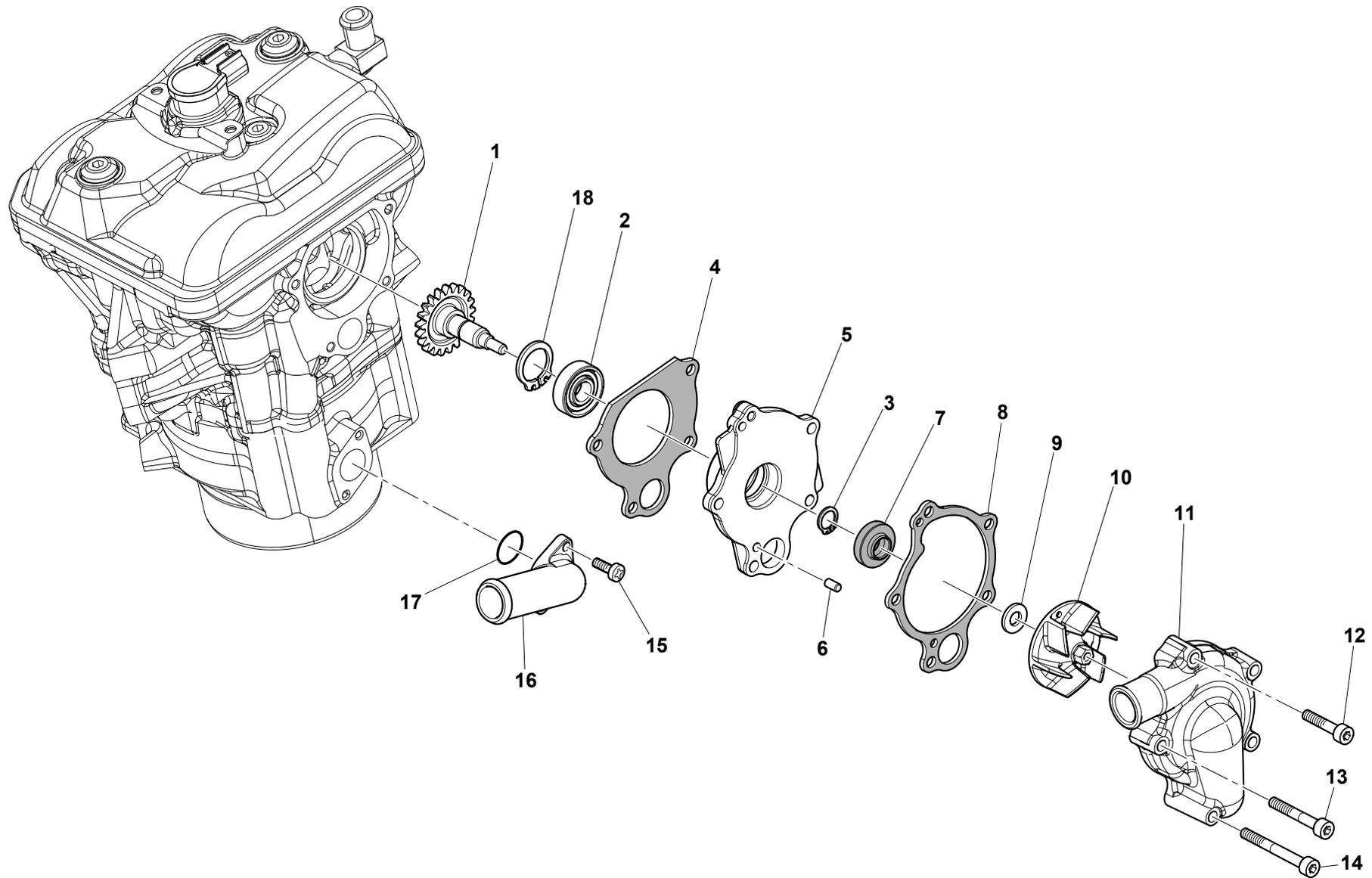



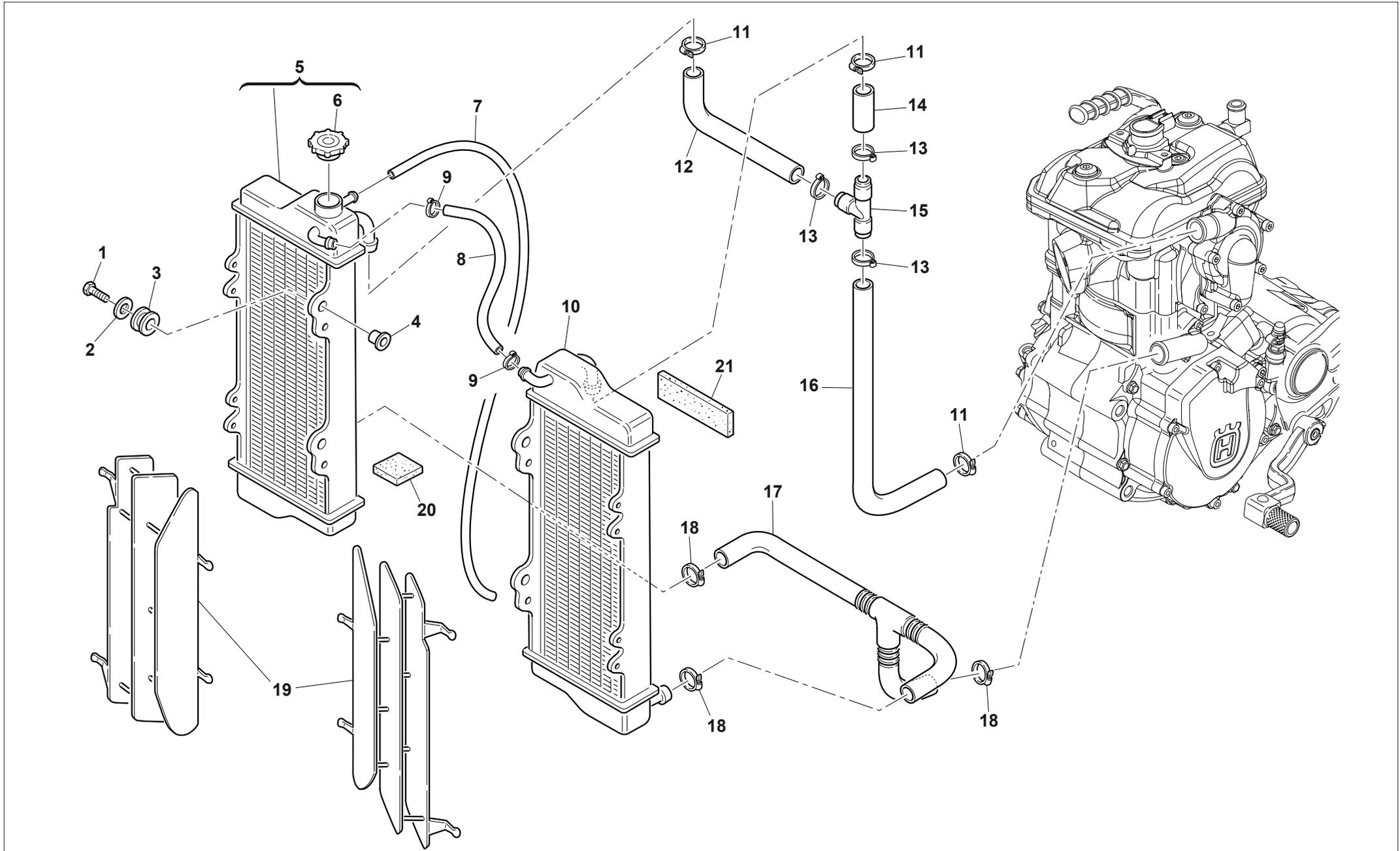

**IMPIANTO DI RAFFREDDAMENTO - COOLING SYSTEM**  
**INSTALLATION DE REFROIDISSEMENT - SCHMIERUNGSSYSTEM**  
**EQUIPO DE ENFRIAMENTO**



Note Notes Notes Marke Notas	Pos. No. Index Pos.	N. Cod. Code No. Nr. Code Code Nr N. Cod.	Q.tà Q.ty Q.te M.ge C.ad	DENOMINAZIONE	NAME	DESIGNATION	BESHREIBUNG	DENOMINACION
	1	Z000 62728	6	Vite	Screw	Vis	Schraube	Tornillo
	2	Z000 59801	6	Rosetta	Washer	Rondelle	Scheibe	Arandela
	3	8000 59803	6	Gommino	Rubber pad	Pièce caoutchouc	Gummistück	Junta de goma
	4	8000 59802	6	Bussola	Bushing	Douille	Buchse	Buje
	5	8538473	1	Radiatore Dx completo	R.H. radiator assy	Radiateur D. compl.	R. Kühler	Radiador Der. compl.
	6	8000 H0260	1	Tappo	Plug	Bouchon	Verschluss	Tapón
	7	9472 00006	1	Tubetto sfiato	Tube	Tuyau	Rohr	Tube
	8	9472 00072	1	Tubo	Pipe	Tuyau	Rohr	Tube
	9	8000 H1981	2	Fascetta	Clamp	Collier	Schelle	Banda
	10	8538474	1	Radiatore Sx completo	L.H. radiator assy	Radiateur G.	L. Kühler	Radiador iz.
	11	8B00 99475	4	Fascetta	Clamp	Collier	Schelle	Banda
	12	8000 B1610	1	Tubo Rad. Dx-Raccordo	Pipe	Tuyau	Schlauch	Tube
	13	8000 50453	3	Fascetta	Clamp	Collier	Schelle	Banda
	14	8A00 A0669	1	Tubo Rad.Sx-Raccordo	Pipe	Tuyau	Schlauch	Tube
	15	8000 A0671	1	Raccordo	Union	Raccord	Anschluss	Empalme
	16	8000 H0016	1	Tubo pompa-raccordo	Pipe	Tuyau	Schlauch	Tube
	17	8000 H3545	1	Tubo Inferiore Rad.	Pipe	Tuyau	Schlauch	Tube
	18	8A00 99475	3	Fascetta	Clamp	Collier	Schelle	Banda
	19	8AA0 A0872	2	Griglia	Grid	Grille	Rost	Parilla
	20	8000 87072	1	Antivibrante	Silent-block	Antivibration	Schwingungsdämpfer	Anti-vibrador
	21	8000 37140	1	Antivibrante	Silent-block	Antivibration	Schwingungsdämpfer	Anti-vibrador

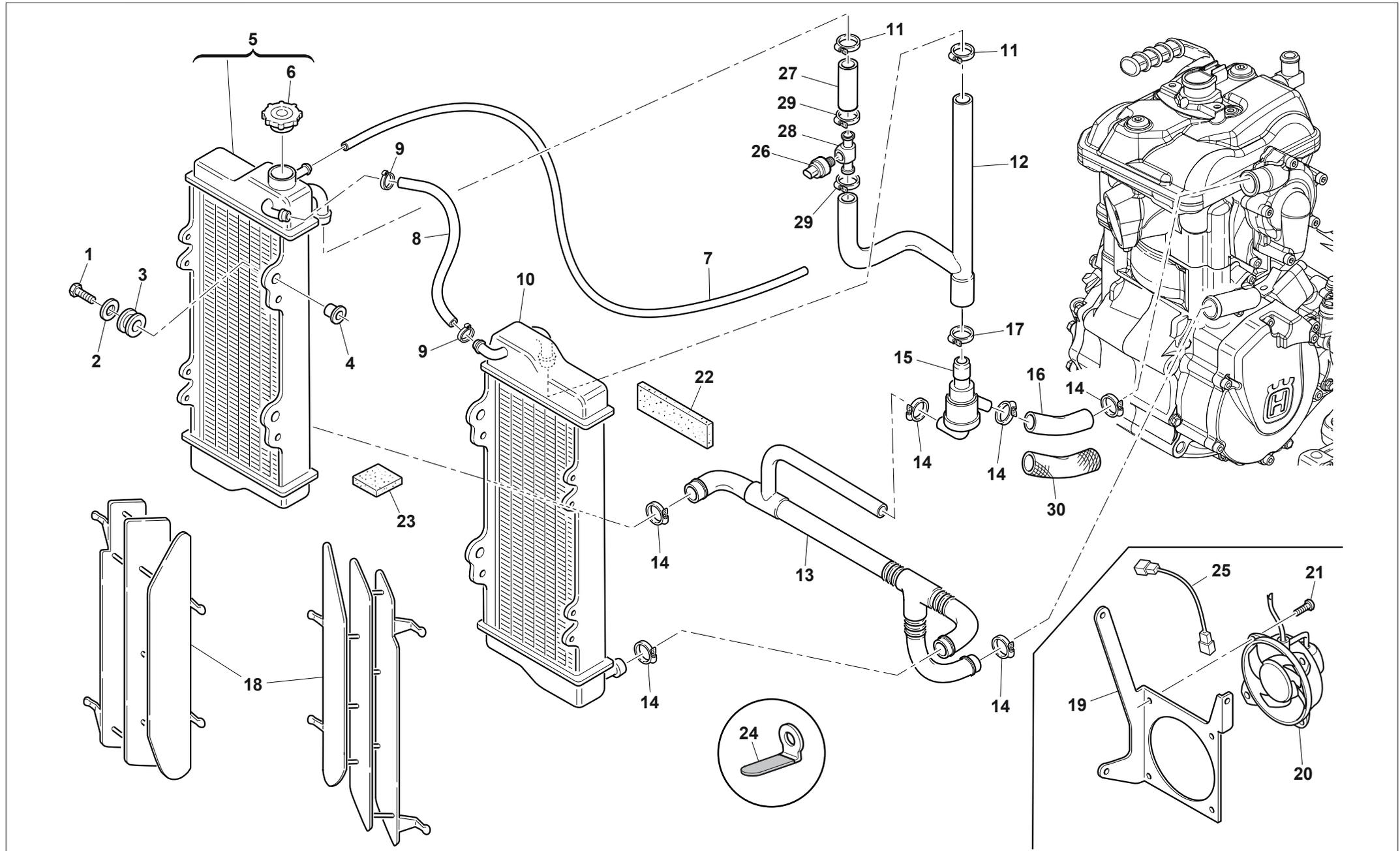

TE-TXC 250/2013  
TE-TXC 310/2013

TAVOLA - DRAWING  
TABLE - BILD - TABLA

18A

IMPIANTO DI RAFFREDDAMENTO - COOLING SYSTEM  
INSTALLATION DE REFROIDISSEMENT - SCHMIERUNGSSYSTEM  
EQUIPO DE ENFRIAMIENTO



Note Notes Notes Marke Notas	Pos. No. Index Pos.	N. Cod. Code No. Nr. Code Code Nr N. Cod.	Q.tà Q.ty Q.te M.ge C.ad	DENOMINAZIONE	NAME	DESIGNATION	BESHREIBUNG	DENOMINACION
	1	Z000 62728	6	Vite	Screw	Vis	Schraube	Tornillo
	2	Z000 59801	6	Rosetta	Washer	Rondelle	Scheibe	Arandela
	3	8000 59803	6	Gommino	Rubber pad	Pièce caoutchouc	Gummistück	Junta de goma
	4	8000 59802	6	Bussola	Bushing	Douille	Buchse	Buje
	5	8538473	1	Radiatore Dx completo	R.H. radiator assy	Radiateur D. compl.	R. Kühler	Radiador Der. compl.
	6	8000 H0260	1	Tappo	Plug	Bouchon	Verschluss	Tapón
	7	9472 00006	1	Tubetto sfiato	Tube	Tuyau	Rohr	Tubo
	8	9472 00072	1	Tubo	Pipe	Tuyau	Rohr	Tubo
	9	8000 H1981	2	Fascetta	Clamp	Collier	Schelle	Banda
	10	8538474	1	Radiatore Sx completo	L.H. radiator assy	Radiateur G.	L. Kühler	Radiador iz.
	11	8A00 99475	2	Fascetta	Clamp	Collier	Schelle	Banda
	12	8538939	1	Tubo superiore	Pipe	Tuyau	Schlauch	Tubo
	13	8000 H3426	1	Tubo inferiore	Pipe	Tuyau	Schlauch	Tubo
	14	8B00 99475	6	Fascetta	Clamp	Collier	Schelle	Banda
	15	8C00 75984	1	Termostato	Thermostat	Thermostat	Thermostat	Termostato
	16	8000 H1979	1	Tubo pompa-termostato	Pipe	Tuyau	Schlauch	Tubo
	17	8000 99475	1	Fascetta	Clamp	Collier	Schelle	Banda
	18	8AA0 A0872	2	Griglia	Grid	Grille	Rost	Parilla
	19	8000 A7861	1	Supporto	Support	Support	Halterung	Soporte
	20	8000 A7715	1	Elettroventola	Fan	Ventilateur	Kühlungsflügel	Aventadýr
	21	ZA00 59572	1	Vite	Screw	Vis	Schraube	Tornillo
	22	8000 37140	1	Antivibrante	Silent-block	Antivibration	Schwingungsdämpfer	Anti-vibrador
	23	8000 87072	1	Antivibrante	Silent-block	Antivibration	Schwingungsdämpfer	Anti-vibrador
	24	8000 H5888	1	Piastrina	Plate	Plaque	Platte	Placa
	25	8538491	1	Cablaggio elettroventola	Fan cable	Cable ventilateur	Kühlungsflügelkabel	Cable aventadór
	26	8538490	1	Interruttore elettroventola	Fan switch	Interrupteur pour ventilateur	Kühlungsflügelschalter	Interruptor aventadór
	27	8538940	1	Tubo	Pipe	Tuyau	Rohr	Tubo
	28	8538910	1	Raccordo	Union	Raccord	Anschluss	Empalme
	29	8A00 99475	2	Fascetta	Clamp	Collier	Schelle	Banda
	30	8000 H7020	1	Guaina di protezione	Sheath protection	Vaine de protection	Hülle	Vaina de protección

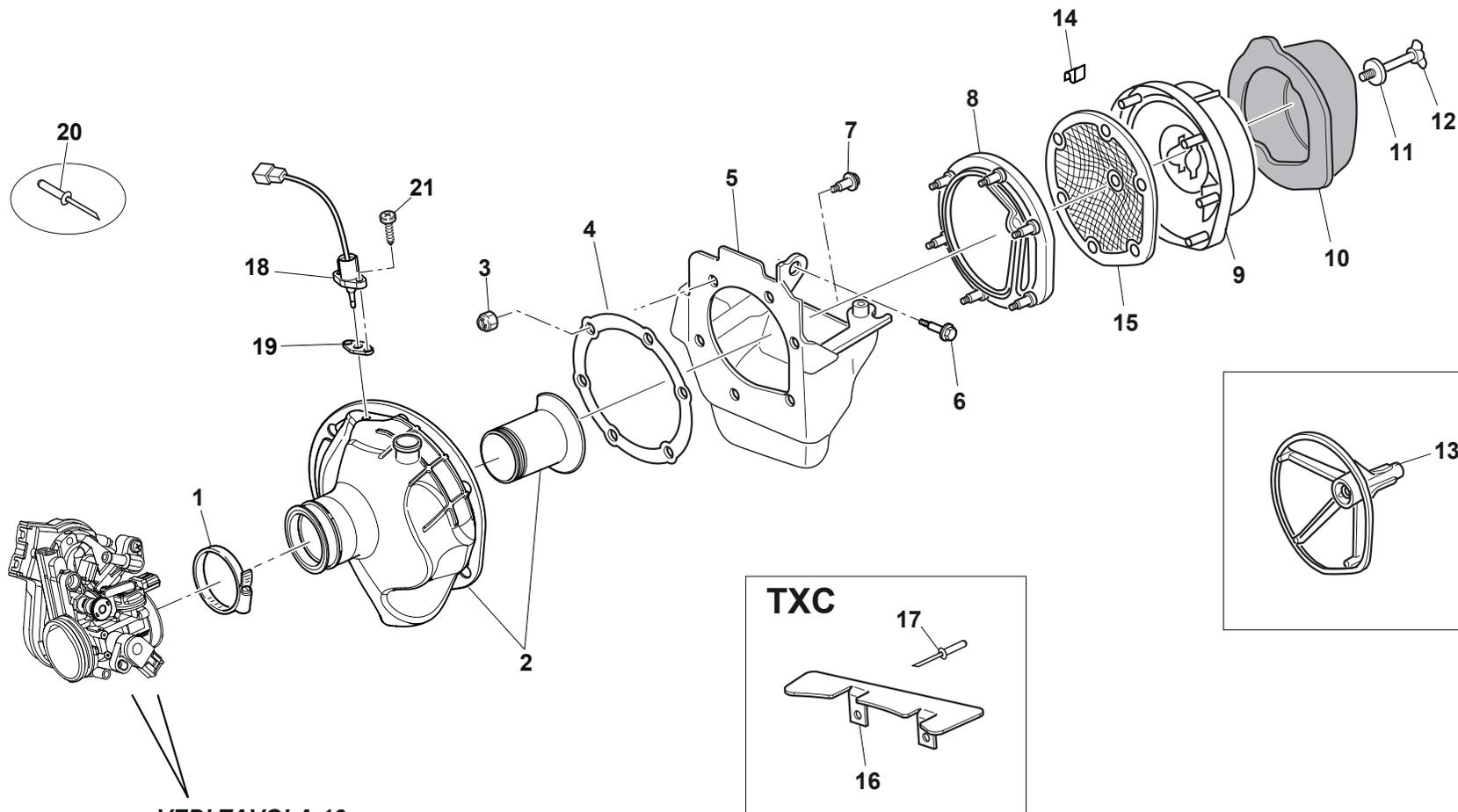

VEDI TAVOLA 16  
SEE DRAWING 16  
VOIR TABLE 16  
SEHEN BILD 16  
VER TABLA 16



TE-TXC 250/2013  
TE-TXC 310/2013

TAVOLA - DRAWING  
TABLE - BILD - TABLA

19

ASPIRAZIONE E FILTRO ARIA - AIR BOX AND FILTER  
ASPIRATION ET FILTRE AIRE - ANSAUGEN UND LUFTFILTER  
ASPIRACIÓN Y FILTRO DE AIRE



Note Notes Notes Marke Notas	Pos. No. Index Pos.	N. Cod. Code No. Nr. Code Code Nr N. Cod.	Q.tà Q.ty Q.te M.ge C.ad	DENOMINAZIONE	NAME	DESIGNATION	BESHREIBUNG	DENOMINACION
	1	8000 98290	1	Fascetta	Clamp	Collier	Schelle	Banda
BW	2	8538672	1	Raccordo	Union	Raccord	Anschluss	Empalme
KT	2	8538673	1	Raccordo	Union	Raccord	Anschluss	Empalme
	3	Z000 40718	6	Dado	Nut	Ecrou	Mutter	Tuerca
	4	8000 B0575	1	Flangia	Flange	Bride	Flansch	Brida
	5	8000 H0054	1	Scatola filtro aria	Air filter box	Boitre filtre	Filterkasten	Caja filtro aire
	6	8A00 A8421	1	Vite	Screw	Vis	Schraube	Tornillo
	7	8B00 A8421	2	Vite	Screw	Vis	Schraube	Tornillo
	8	8000 H3013	1	Flangia	Flange	Bride	Flansch	Brida
WB	9	8000 H0805	1	Gabbia filtro	Cleaner cage	Cage pour filtre	Filterkafig	Caja filtro
	10	8000 72641	1	Filtro aria	Air filter	Filtre à air	Luftfilter	Filtro aire
	11	62ND 15549	1	Rosetta	Washer	Rondelle	Scheibe	Arandela
	12	ZA00 37947	1	Vite	Screw	Vis	Schraube	Tornillo
KT	13	8000 69549	1	Gabbia filtro	Cleaner cage	Cage pour filtre	Filterkafig	Caja filtro
	14	8000 72494	1	Molletta	Tube clip	Ressort	Feder	Resorte
	15	8000 A0656	1	Protezione antifiamma	Guard	Protection	Schutz	Protección
	16	8000 H7058	1	Protezione	Guard	Protection	Schutz	Protección
	17	8000 33371	4	Rivetto	Rivet	Rivet	Niet	Remache
	18	8000 H3646	1	Sensore temperatura aria	Air temperature sensor	Capteur temperature air	Lufttemperaturesensor	Sensòr temperatura aire
	19	8000 H7383	2	Piastrina	Plate	Plaque	Platte	Placa
	20	8000 H7531	2	Rivetto	Rivet	Rivet	Niet	Remache
	21	60ND 02487	2	Vite	Screw	Vis	Schraube	Tornillo

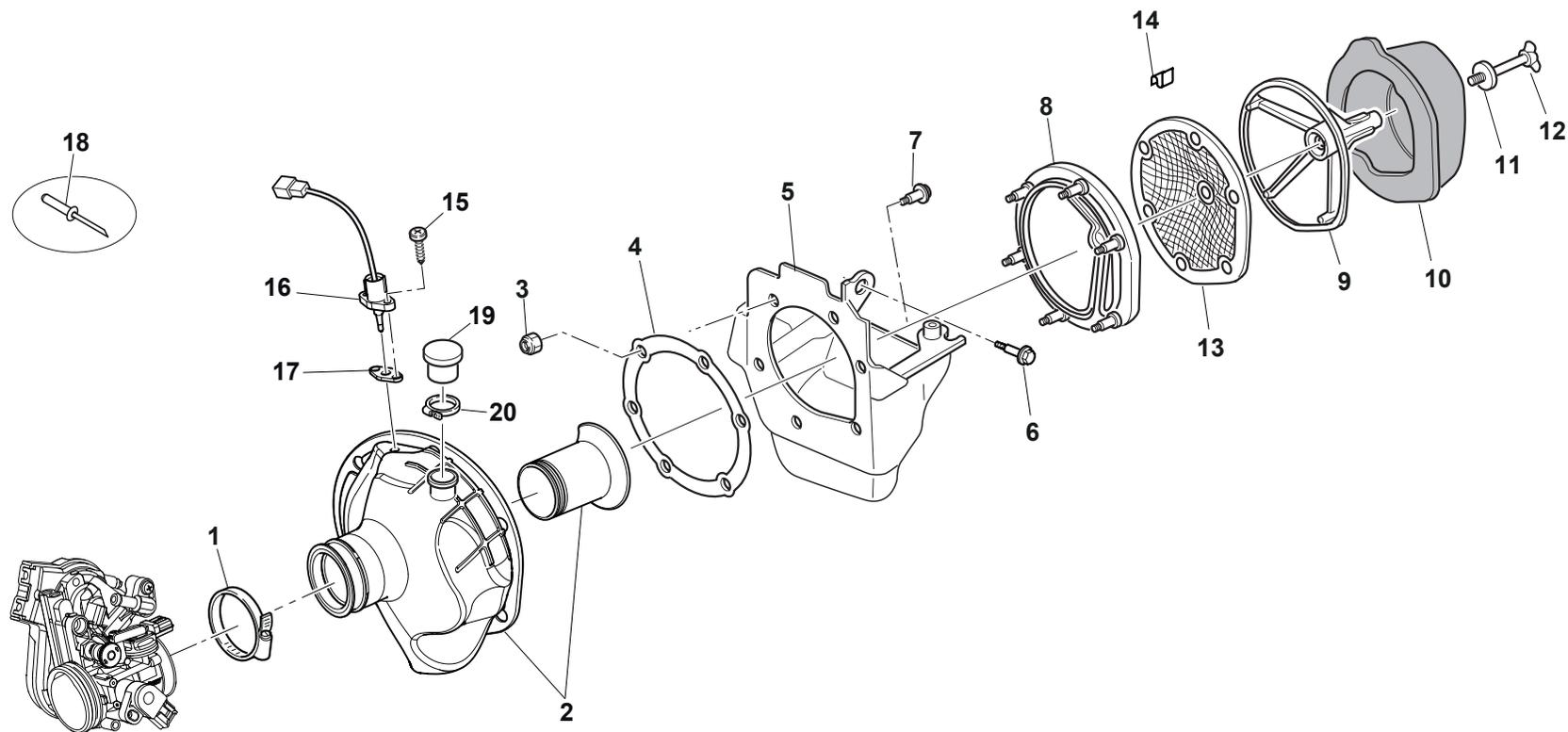

VEDI TAVOLA 16  
SEE DRAWING 16  
VOIR TABLE 16  
SEHEN BILD 16  
VER TABLA 16



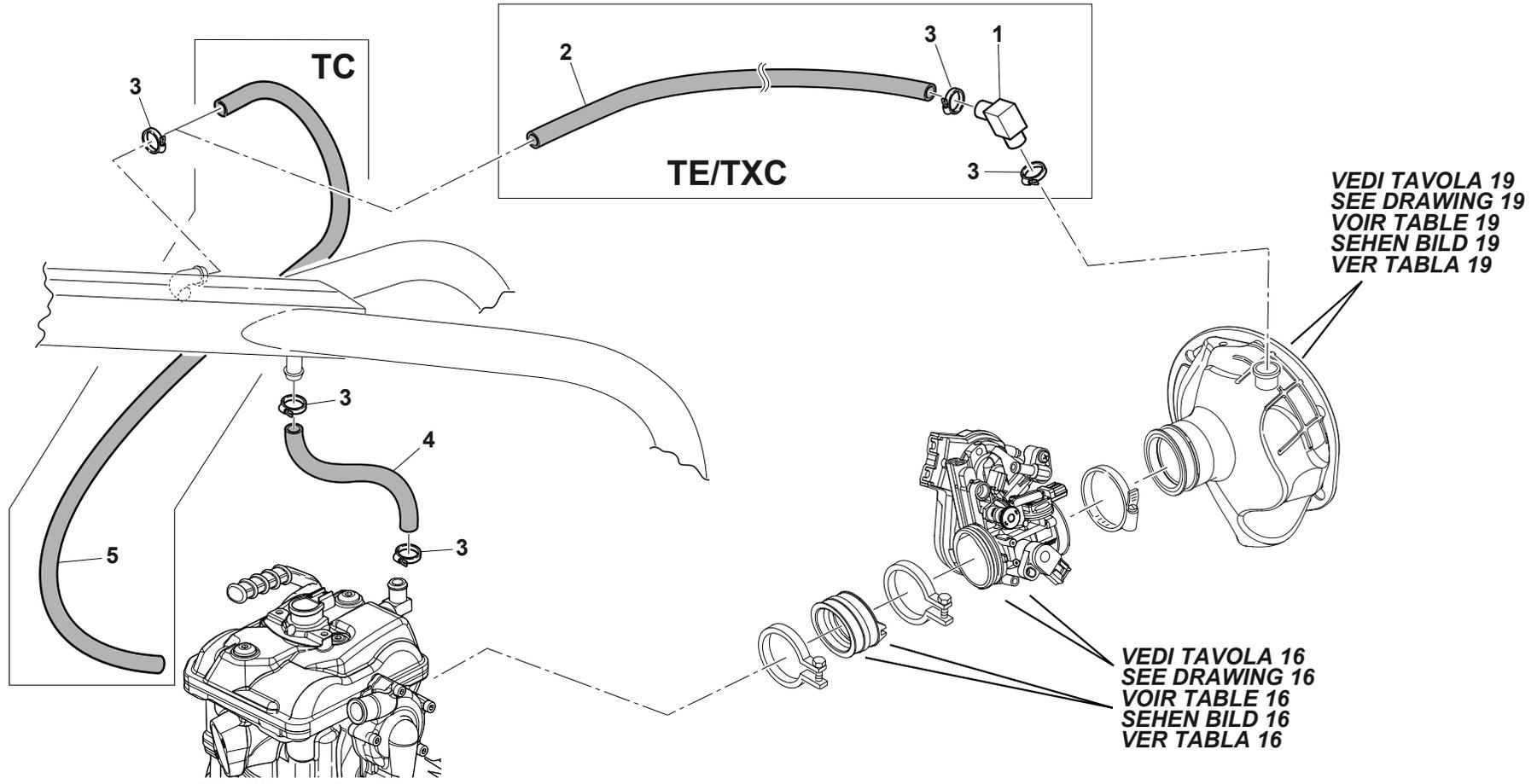



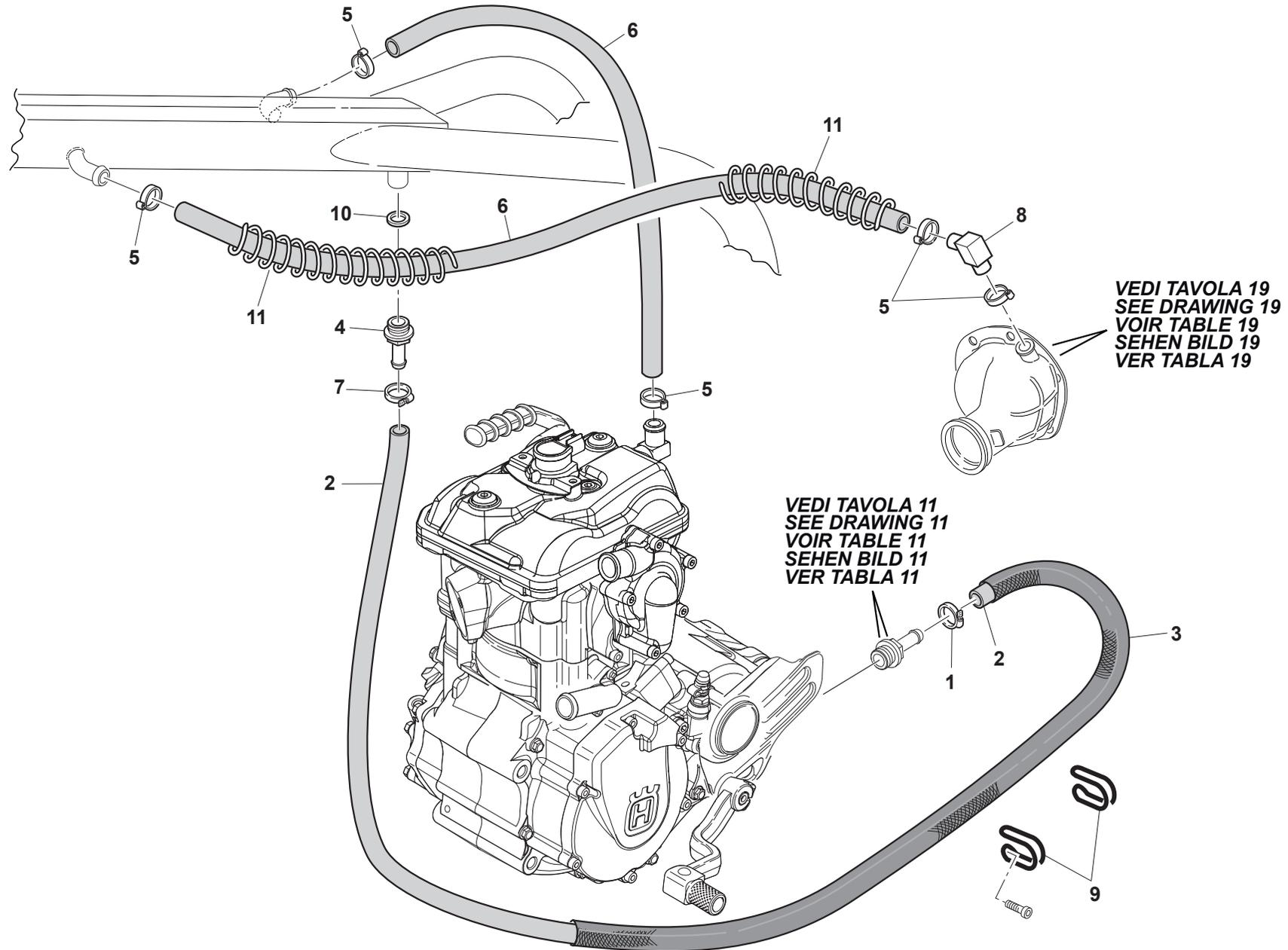



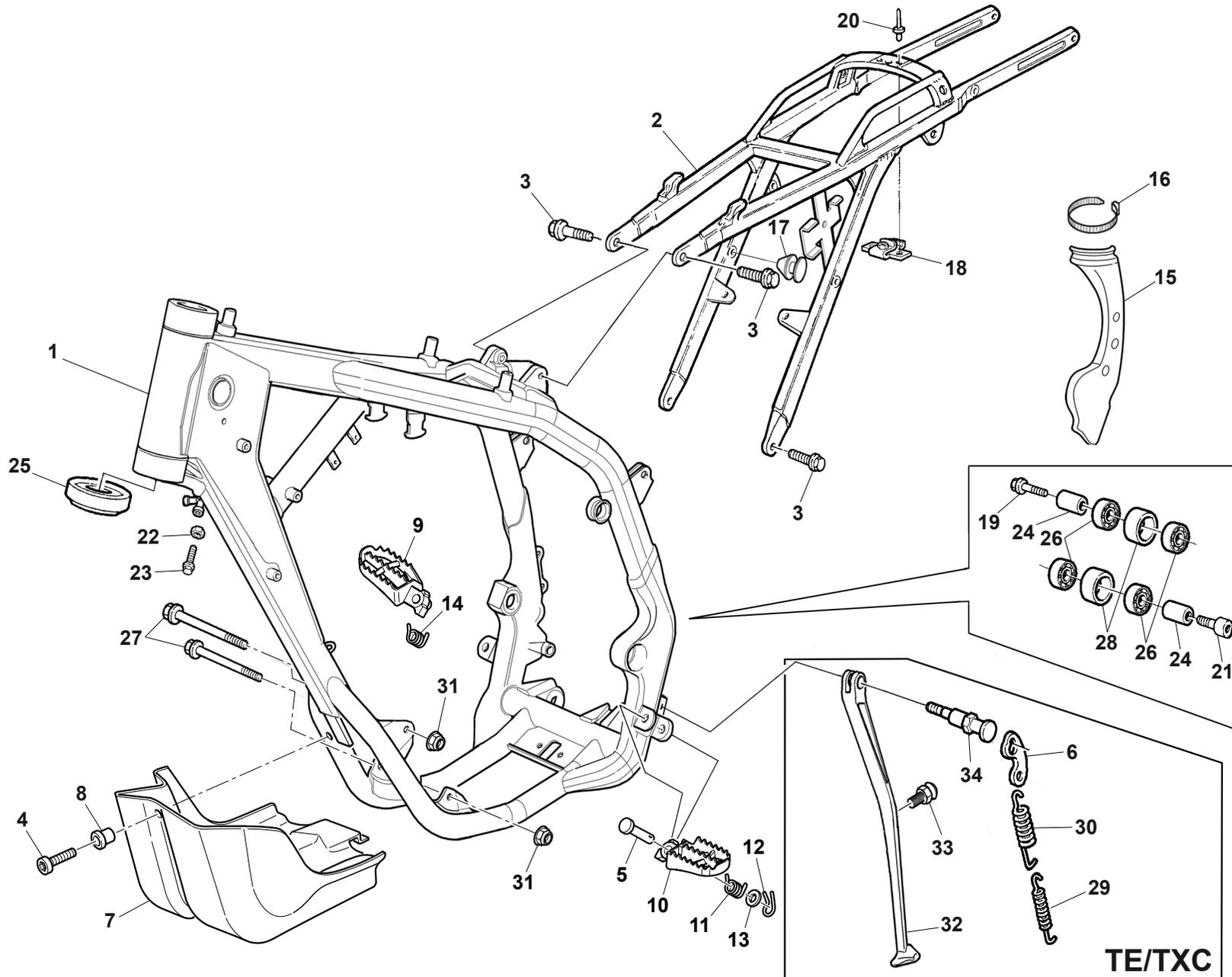

TE/TXC



TELAIO, PEDANE - FRAME, FOOT RESTS  
CADRE, REPOSE PIEDS - RAHMEN, FUSSBRETT  
BASTIDOR, REPOSAPIES

Note Notes Notes Marke Notas	Pos. No. N. Index Pos.	N. Cod. Code No. Nr. Code Code Nr N. Cod.	Q.tà Q.ty Q.te M.ge C.ad	DENOMINAZIONE	NAME	DESIGNATION	BESHREIBUNG	DENOMINACION
C	1	8000 H6625	1	Telaio anteriore	Front frame	Chassis antérieur	Rahmen vorrdrer	Bastidor delantero
W	1	8538425	1	Telaio anteriore	Front frame	Chassis antérieur	Rahmen vorrdrer	Bastidor delantero
B	1	8538426	1	Telaio anteriore	Front frame	Chassis antérieur	Rahmen vorrdrer	Bastidor delantero
T	1	8538493	1	Telaio anteriore	Front frame	Chassis antérieur	Rahmen vorrdrer	Bastidor delantero
K	1	8538494	1	Telaio anteriore	Front frame	Chassis antérieur	Rahmen vorrdrer	Bastidor delantero
C	2	8000 H1513	1	Telaio posteriore	Rear frame side	Chassis arrière	Sattelbrücke	Cuadro posterior
KTWB	2	8538691	1	Telaio posteriore	Rear frame side	Chassis arrière	Sattelbrücke	Cuadro posterior
	3	Z000 69056	4	Vite flangiata	Flange bolt	Boulon de bride	Flanschschraube	Perno de reborde
	4	Y000 60898	1	Vite	Screw	Vis	Schraube	Tornillo
	5	Y000 73140	2	Perno	Pin	Pivot	Bolzen	Perno
	6	8000 A0267	1	Piastrina	Plate	Plaque	Platte	Placa
	7	8000 H1491	1	Paramotore	Engine guard	Garde moteur	Motorschutz	Para motor
	8	80B0 69429	1	Bussola	Bushing	Douille	Buchse	Buje
	9	80A0 89953	1	Pedana destra	R.H. foot-rest	Repose-pieds D.	R. Fussraste	Pedal delnt. derech. compl.
	10	80A0 89962	1	Pedana sinistra	L.H. foot-rest	Repose-pieds G.	L. Fussraste	Pedal delant. izrdo. compl.
	11	8000 96907	1	Molla Sx	L.H. spring	Ressort G.	Feder L.	Resorte Iz.
	12	64ND 20068	2	Copiglia	Split pin	Goupille	Splint	Clavija
	13	ZA00 01815	2	Rosetta	Washer	Rondelle	Scheibe	Arandela
	14	8000 96908	1	Molla Dx	R.H. spring	Ressort D.	Feder R.	Resorte Der.
	15	8000 H3435	1	Protezione telaio Sx	L.H. frame guard	Protection chassis G.	Rahmenschutz Links	Protección bastidor izquierda
	16	8000 56444	1	Fascetta	Clamp	Collier	Schelle	Banda
	17	8000 B0841	1	Tappo	Plug	Bouchon	Verschluss	Tapón
	18	8000 69150	1	Piastrina	Plate	Plaque	Platte	Placa
	19	Z000 62796	1	Vite	Screw	Vis	Schraube	Tornillo
	20	8000 33373	2	Rivetto	Rivet	Rivet	Niet	Remache
	21	60ND 02559	1	Vite	Screw	Vis	Schraube	Tornillo
	22	Z000 17810	2	Dado	Nut	Ecrou	Mutter	Tuerca
	23	YB00 92876	2	Vite	Screw	Vis	Schraube	Tornillo
	24	8A00 59434	2	Distanziale	Spacer	Entretoise	Distanzstück	Separador
	25	8000 87243	2	Cuscinetto	Bearing	Roulement	Kugellager	Cojinete
	26	8000 63312	4	Cuscinetto	Bearing	Roulement	Kugellager	Cojinete
	27	YN00 73458	2	Vite	Screw	Vis	Schraube	Tornillo
	28	8AA0 59433	2	Rullo catena	Roller	Aiguille	Rolle	Rodillo

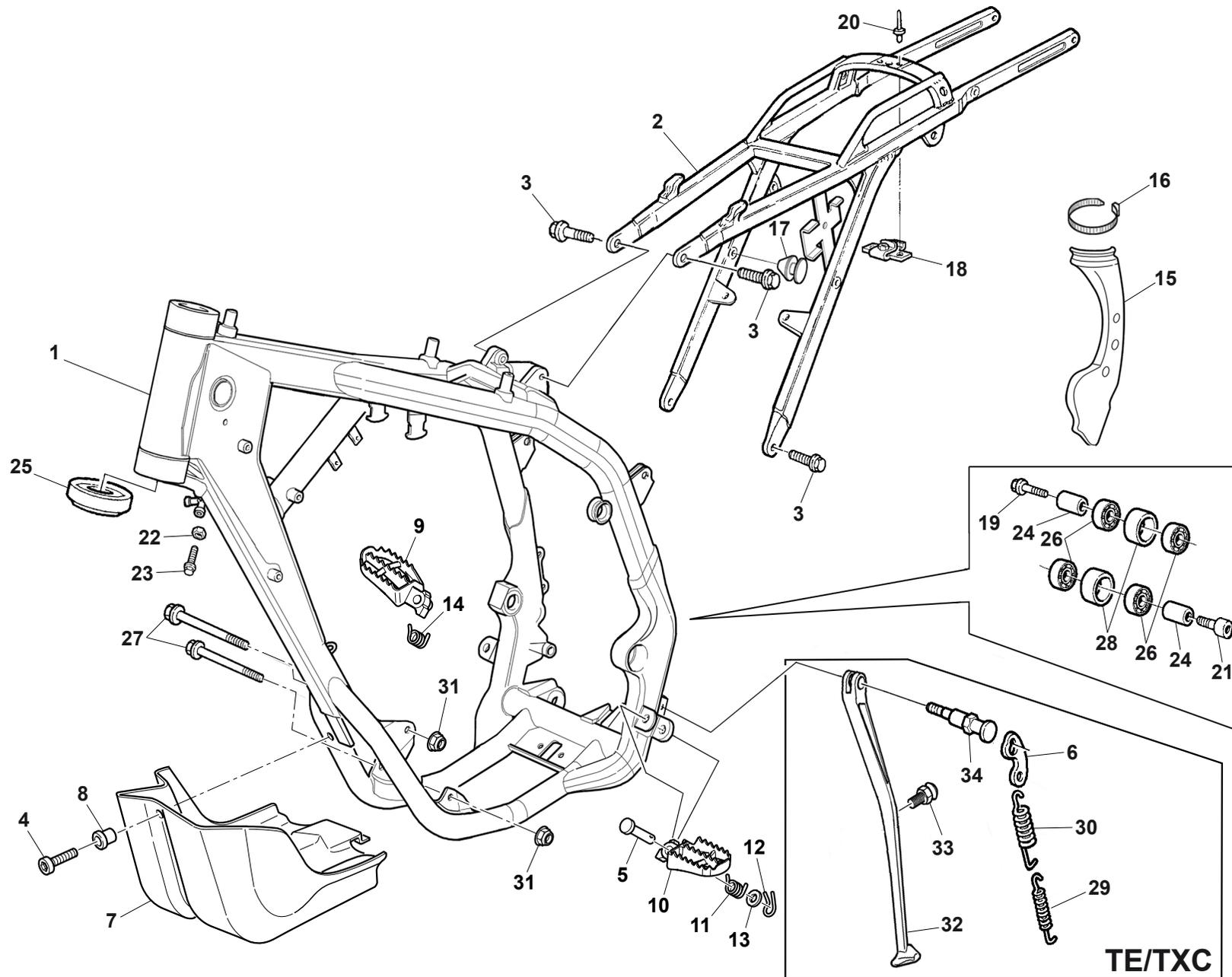



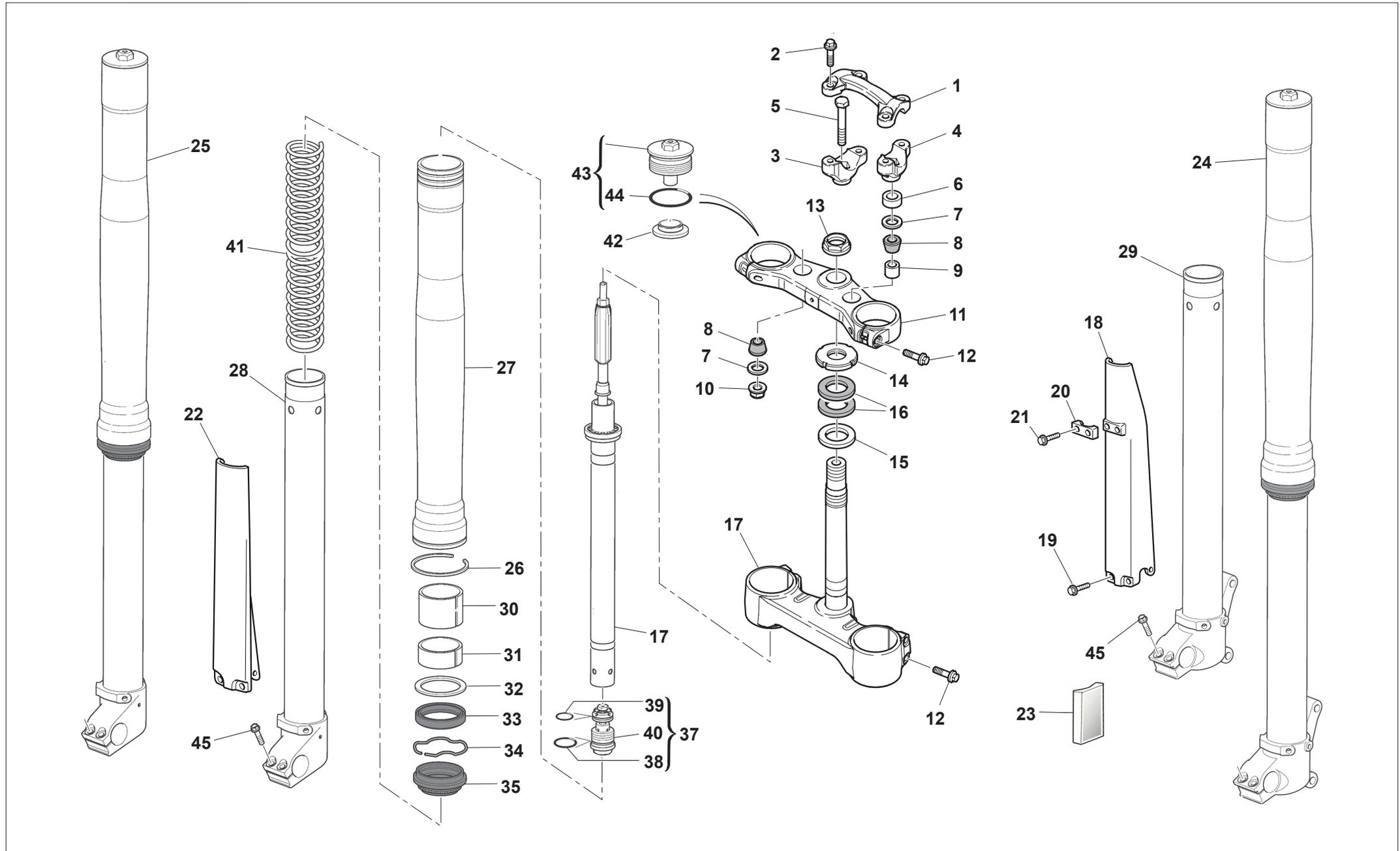

TE 250/2013  
TE 310/2013

TAVOLA - DRAWING  
TABLE - BILD - TABLA

21

**SOSPENSIONE ANTERIORE - FRONT FORK ASSEMBLY**  
**SUSPENSION AVANT - VORDERTELESKOPGABEL**  
**SUSPENSION DELANTERA**



Note Notes Notes Marke Notas	Pos. No. N. Index Pos.	N. Cod. Code No. Nr. Code Code Nr N. Cod.	Q.tà Q.ty Q.te M.ge C.ad	DENOMINAZIONE	NAME	DESIGNATION	BESHREIBUNG	DENOMINACION
	1	8000 H1358	1	Morsetto superiore	Upper clamp	Etrier sup.	Ober Brücke	Brida sup.
	2	8A00 B1959	4	Vite flangiata	Flange bolt	Boulon de bride	Flanschschraube	Perno de reborde
	3	8000 H1715	1	Morsetto inferiore Dx	R.H. lower clamp	Etrier inf. D.	Untere Brücke R.	Brida inf. Der.
	4	8000 H1357	2	Morsetto inferiore Sx	L.H. lower clamp	Etrier inf. G.	Untere Brücke L.	Brida inf. izq.
	5	60ND 01219	2	Vite	Screw	Vis	Schraube	Tornillo
	6	8A00 A6683	2	Distanziale	Spacer	Entretoise	Distanzstück	Separador
	7	8000 60234	4	Rosetta piana	Washer	Rondelle	Scheibe	Arandela
	8	8000 H1385	4	Gommino	Rubber pad	Pièce caoutchouc	Gummistück	Junta de goma
	9	8000 H1714	2	Distanziale	Spacer	Entretoise	Distanzstück	Separador
	10	Z000 61314	2	Dado autobloccante	Nut	Mutter	Ecrou	Tuerca
	11	8000 H1286	1	Testa di sterzo	Steering head	Tête direction	Lenkkopf	Cabezal de dirección
	12	8E00 B1959	6	Vite flangiata	Flange bolt	Boulon de bride	Flanschschraube	Perno de reborde
	13	8A00 69315	1	Dado	Nut	Ecrou	Mutter	Tuerca
	14	8A00 87717	1	Ghiera	Ring nut	Embout	Nutmutter	Virola
	15	Z000 87736	1	Rosetta piana	Washer	Rondelle	Scheibe	Arandela
	16	8000 87745	2	Guarnizione di tenuta	Gasket	Garniture	Dichtung	Junta
	17	8000 H1396	1	Base di sterzo con perno	Steering crown with pin	Socle de direction avec pivot	Gabelbrücke mit Bolzen	Base de dirección con perno
	18	80A0 A8481	1	Protezione steli Sx NERO	Guard L.H. BLACK	Protection D. NOIR	Schutz L. SCHWARZ	Protección izq. NEGRO
	19	8000 A8423	6	Vite	Screw	Vis	Schraube	Tornillo
	20	80A0 A0633	1	Piastrina	Plate	Plaque	Platte	Placa
	21	ZA00 84658	2	Vite	Screw	Vis	Schraube	Tornillo
	22	80A0 A8482	1	Protezione steli Dx NERO	Guard R.H. BLACK	Protection G. NOIR	Schutz R. SCHWARZ	Protección der. NEGRO
	23	8000 74842	2	Catadiottro ambra	Reflector amber	Catadioptrique ambre	Rückstrahler Amber	Catafaros àmbar
	24	8000 H6487	1	Gamba Sx completa	L.H. fork leg assy	Fourche compl. G.	Telegabel, Kpl. L.	Horquill izq. compl.
	25	8000 H6486	1	Gamba Dx completa	R.H. fork leg assy	Fourche complète D.	Telegabel Kpl. R.	Horquilla derech. compl.
	26	8000 H2672	2	Anello di fermo	Stop ring	Bague d'arrêt	Haltering	Anillo de retención
	27	8000 H2656	2	Portastelo	Outer tube	Tuyau	Rohr	Tubo
	28	8000 H2686	1	Stelo Dx completo	R.H. slider assy	Montant D. compl.	Bein, Kpl. R.	Deslizable der. compl.
	29	8000 H2687	1	Stelo Sx completo	L.H. slider assy	Montant G. compl.	Bein, Kpl. L.	Deslizable izrda. compl.
	30	8000 H2659	2	Bussola	Bushing	Douille	Buchse	Buje
	31	8000 H2660	2	Bussola	Bushing	Douille	Buchse	Buje
	32	8000 H2661	2	Rosetta piana	Washer	Rondelle	Scheibe	Arandela
	33	8000 H2662	2	Anello di tenuta	Seal ring	Bague d'étancheite	Dichtring	Anillo de retención

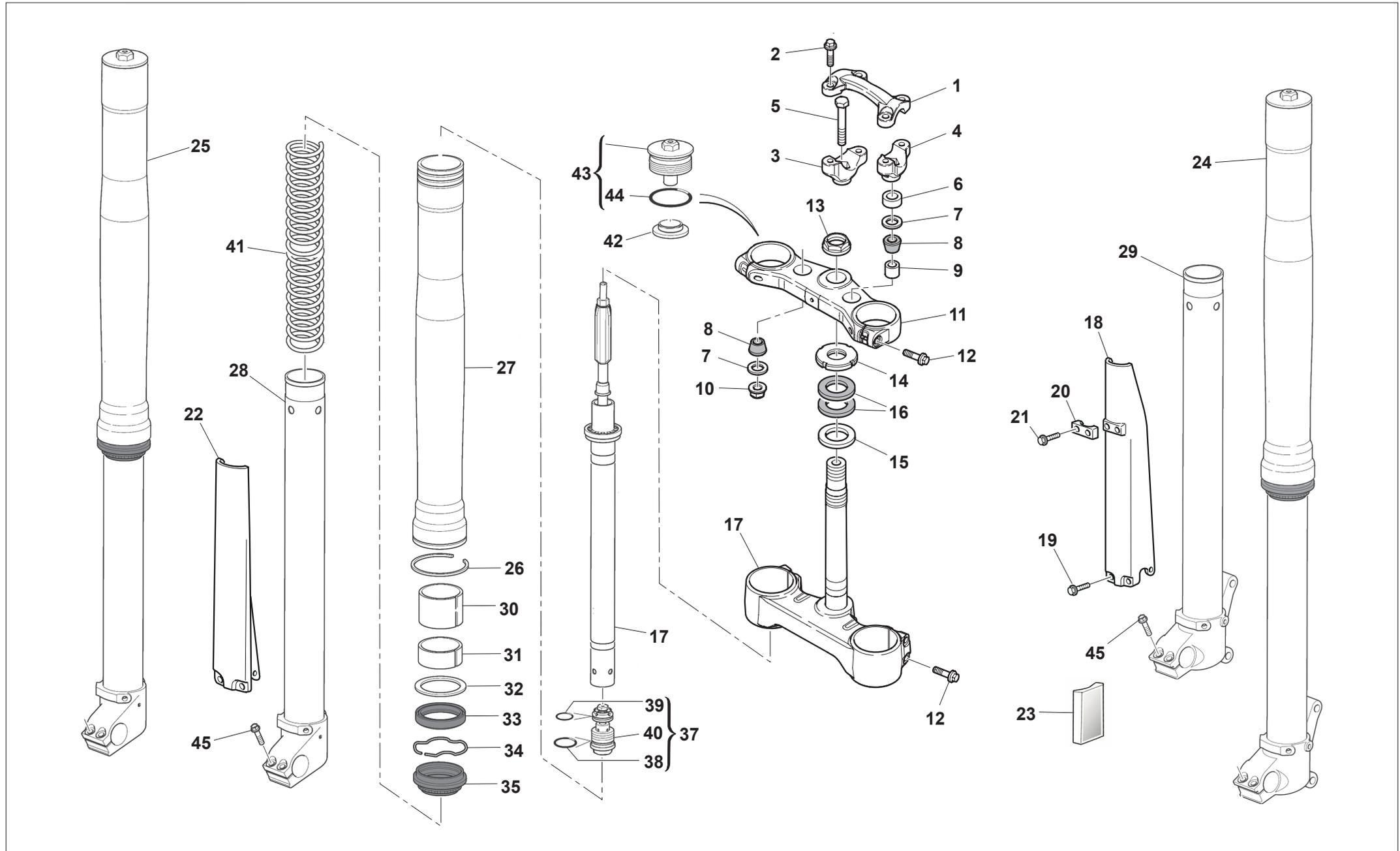



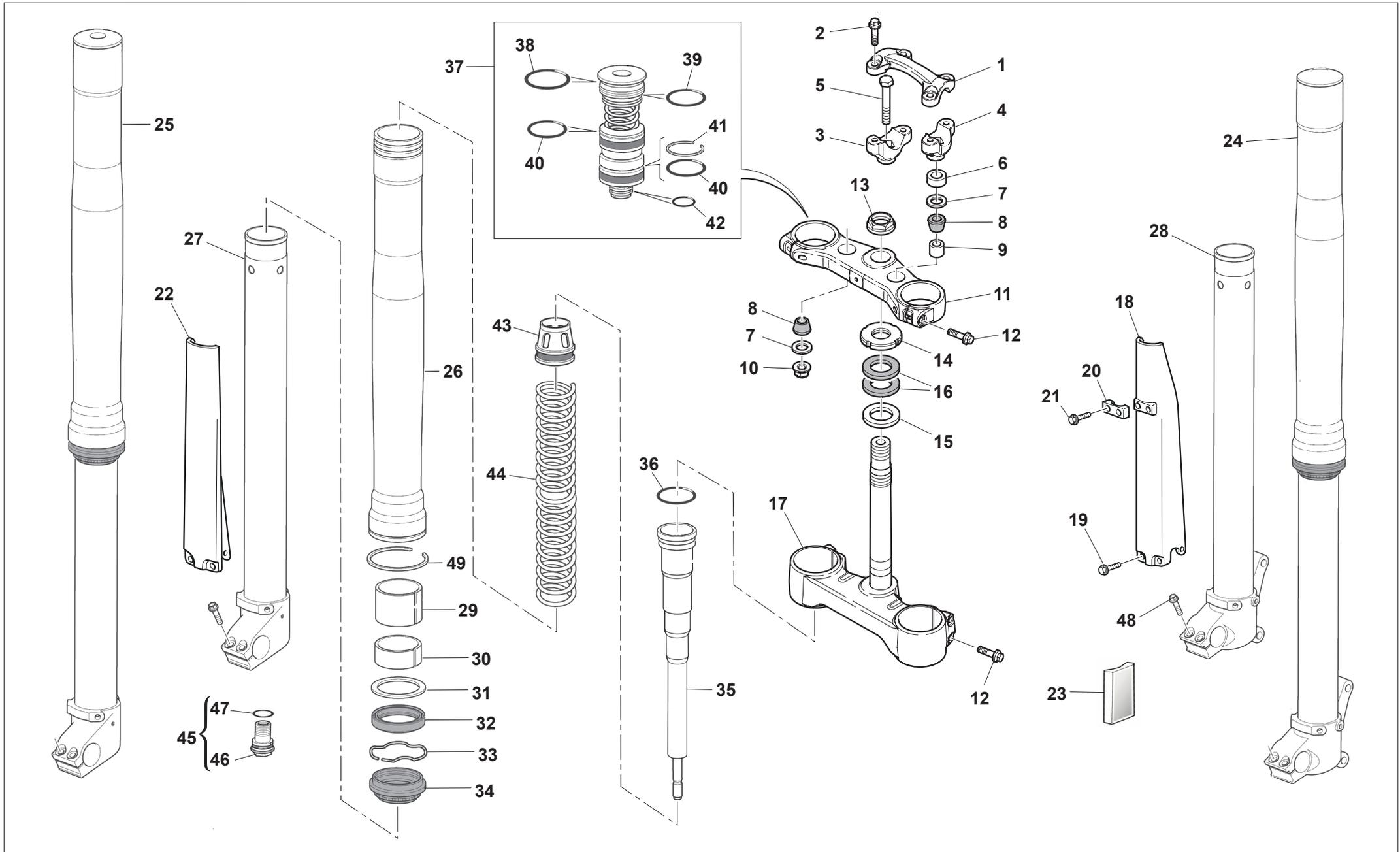



**TXC-TC 250/2013**  
**TXC 310/2013**

TAVOLA - DRAWING  
TABLE - BILD - TABLA

**21A**

**SOSPENSIONE ANTERIORE - FRONT FORK ASSEMBLY**  
**SUSPENSION AVANT - VORDERTELESKOPGABEL**  
**SUSPENSION DELANTERA**



Note Notes Marke Notas	Pos. No. Index Pos.	N. Cod. Code No. Nr. Code Code Nr N. Cod.	Q.tà Q.ty Q.te M.ge C.ad	DENOMINAZIONE	NAME	DESIGNATION	BESHREIBUNG	DENOMINACION
	1	8000 H1358	1	Morsetto superiore	Upper clamp	Etrier sup.	Ober Brücke	Brida sup.
	2	8000 B1959	4	Vite	Screw	Vis	Schraube	Tornillo
	3	8000 H1715	2	Morsetto inferiore Dx	R.H. lower clamp	Etrier inf. D.	Untere Brücke R.	Brida inf. Der.
	4	8000 H1357	1	Morsetto inferiore Sx	L.H. lower clamp	Etrier inf. G.	Untere Brücke L.	Brida inf. izq.
	5	60ND 01219	2	Vite	Screw	Vis	Schraube	Tornillo
	6	8A00 A6683	2	Distanziale	Spacer	Entretoise	Distanzstück	Separador
	7	8000 60234	4	Rosetta piana	Washer	Rondelle	Scheibe	Arandela
	8	8000 H1385	4	Gommino	Rubber pad	Pièce caoutchouc	Gummistück	Junta de goma
	9	8000 H1714	2	Distanziale	Spacer	Entretoise	Distanzstück	Separador
	10	Z000 61314	2	Dado autobloccante	Nut	Mutter	Ecrou	Tuerca
	11	8000 H1286	1	Testa di sterzo	Steering head	Tête direction	Lenkkopf	Cabezal de dirección
	12	8E00 B1959	6	Vite flangiata	Flange bolt	Boulon de bride	Flanschschraube	Perno de reborde
	13	8A00 69315	1	Dado	Nut	Ecrou	Mutter	Tuerca
	14	8A00 87717	1	Ghiera	Ring nut	Embout	Nutmutter	Virola
	15	Z000 87736	1	Rosetta piana	Washer	Rondelle	Scheibe	Arandela
	16	8000 87745	2	Guarnizione di tenuta	Gasket	Garniture	Dichtung	Junta
	17	8000 H1354	1	Base di sterzo con perno	Steering crown with pin	Socle de direction avec pivot	Gabelbrücke mit Bolzen	Base de dirección con perno
	18	80A0 A8481	1	Protezione steli Sx NERO	Guard L.H. BLACK	Protection D. NOIR	Schutz L. SCHWARZ	Protección izq. NEGRO
	19	8000 A8423	6	Vite	Screw	Vis	Schraube	Tornillo
	20	80A0 A0633	1	Piastrina	Plate	Plaque	Platte	Placa
	21	ZA00 84658	2	Vite	Screw	Vis	Schraube	Tornillo
	22	80A0 A8482	1	Protezione steli Dx NERO	Guard R.H. BLACK	Protection G. NOIR	Schutz R. SCHWARZ	Protección der. NEGRO
	23	8000 74842	1	Catadiottro ambra	Reflector amber	Catadioptrique ambre	Rückstrahler Amber	Catafaros àmbar
CX	24	8000 H6489	1	Gamba Sx completa	L.H. fork leg assy	Fourche compl. G.	Telegabel, Kpl. L.	Horquill izq. compl.
KTCU	24	8000 H7331	1	Gamba Sx completa	L.H. fork leg assy	Fourche compl. G.	Telegabel, Kpl. L.	Horquill izq. compl.
CX	25	8000 H6490	1	Gamba Dx completa	R.H. fork leg assy	Fourche complète D.	Telegabel Kpl. R.	Horquilla derech. compl.
KTCU	25	8000 H7332	1	Gamba Dx completa	R.H. fork leg assy	Fourche complète D.	Telegabel Kpl. R.	Horquilla derech. compl.
	26	8000 H2656	2	Portastelo	Outer tube	Tuyau	Rohr	Tubo
	27	8000 H2658	1	Stelo Dx compl.	R.H. slider assy	Montant D. compl.	Bein, Kpl. R.	Deslizable der. compl.
	28	8000 H2657	1	Stelo Sx compl.	L.H. slider assy	Montant G. compl.	Bein, Kpl. L.	Deslizable izrda. compl.
	29	8000 H2659	2	Bussola	Bushing	Douille	Buchse	Buje
	30	8000 H2660	2	Bussola	Bushing	Douille	Buchse	Buje
	31	8000 H2661	2	Rosetta piana	Washer	Rondelle	Scheibe	Arandela

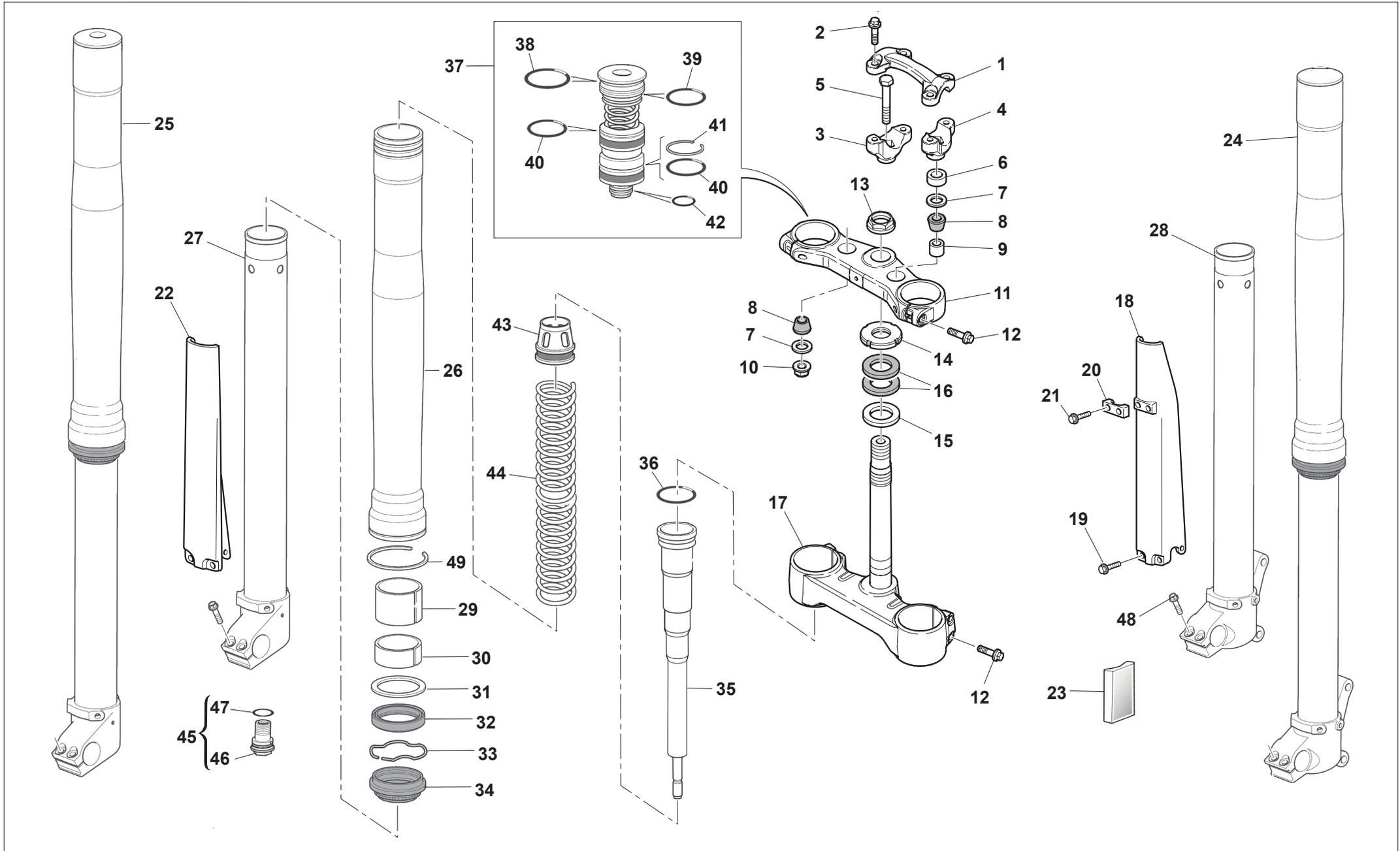





FORCELLONE POSTERIORE- REAR SWING ARM  
FOURCHE ARRIERE - HINTERGABEL  
HORQUILLA TRASERA

Note Notes Notes Marke Notas	Pos. No. N. Index Pos.	N. Cod. Code No. Nr. Code Code Nr N. Cod.	Q.tà Q.ty Q.te M.ge C.ad	DENOMINAZIONE	NAME	DESIGNATION	BESHREIBUNG	DENOMINACION
	1	8000 H0680	1	Forcellone completo	Compl. fork	Fourche complete	Gabel, Kpl.	Horquilla compl.
	2	Z000 71622	2	Bussola	Bushing	Douille	Buchse	Buje
DWG	3	Z000 81628	4	Vite	Screw	Vis	Schraube	Tornillo
	4	8000 H1320	1	Pattino catena	Chain slider	Glissière de chaîne	Gleitbahn	Platode catena
WB	5	Z000 67997	1	Vite	Screw	Vis	Schraube	Tornillo
WB	6	Z000 36137	4	Rosetta	Washer	Rondelle	Scheibe	Arandela
WB	7	Z000 56443	1	Dado	Nut	Ecrou	Mutter	Tuerca
WB	8	8000 H2125	1	Distanziale	Spacer	Entretoise	Distanzstück	Separador
WB	9	Z000 20536	4	Vite	Screw	Vis	Schraube	Tornillo
DWG	10	8000 A2352	1	Prolunga per copricatena	Chain guard extension	Carter de chaîne extension	Kettenkastenverlängerung	Prolonga por cubre-cadena
	11	8000 76283	4	Gabbia a rullini	Needle cage	Cage à aiguilles	Nadelkaefig	Jaula de agujas del cojinete
	12	8000 A6629	2	Distanziale	Spacer	Entretoise	Distanzstück	Separador
	13	8000 H1549	1	Perno forcellone	Fork pin	Pivot fourche	Gabelbolzen	Perno horquilla
TKC	14	Z000 20536	2	Vite	Screw	Vis	Schraube	Tornillo
	15	8000 B1166	1	Guida tubo	Guide ring	Bague de guide	Rohrring	Guía-cable
WB	16	8AB0 73909	1	Copricatena	Chain guard	Carter de chaîne	Kettenkasten	Cubre-cadena
WT	17	Z000 36137	2	Rosetta	Washer	Rondelle	Scheibe	Arandela
	18	8000 96944	1	Tendicatena DX	Chain adjuster Right	Tendeur de chaîne Droite	Kettenspanner R.	Tensor de cadena Derecha
	19	Z000 71623	1	Dado	Nut	Ecrou	Mutter	Tuerca
	20	ZC00 61121	2	Vite	Screw	Vis	Schraube	Tornillo
	21	Z000 17810	2	Dado	Nut	Ecrou	Mutter	Tuerca
	22	8000 69282	2	Bussola	Bushing	Douille	Buchse	Buje
WB	23	ZA00 67997	1	Vite	Screw	Vis	Schraube	Tornillo
WB	24	8000 H3033	7	Scodellino	Cup	Couvette	Teller	Cubeta
WB	25	ZC00 67997	1	Vite	Screw	Vis	Schraube	Tornillo
WB	26	8A00 69282	2	Bussola	Bushing	Douille	Buchse	Buje
KCT	27	Z000 67997	2	Vite	Screw	Vis	Schraube	Tornillo
	28	8000 74016	1	Gamba laterale	Side stand	Bequille lat.	Seitenständer	Horquilla lateral
KCT	29	8000 H3034	6	Scodellino	Cup	Couvette	Teller	Cubeta
	30	Z000 36137	2	Rosetta	Washer	Rondelle	Scheibe	Arandela
	31	8000 H7668	1	Staffa guidacatena	Bracket	Etrier	Buegel	Brida
	32	8000 32388	1	Rosetta	Washer	Rondelle	Scheibe	Arandela
	33	Z000 62795	1	Vite flangiata	Flange bolt	Boulon de bride	Flanschschraube	Perno de reborde

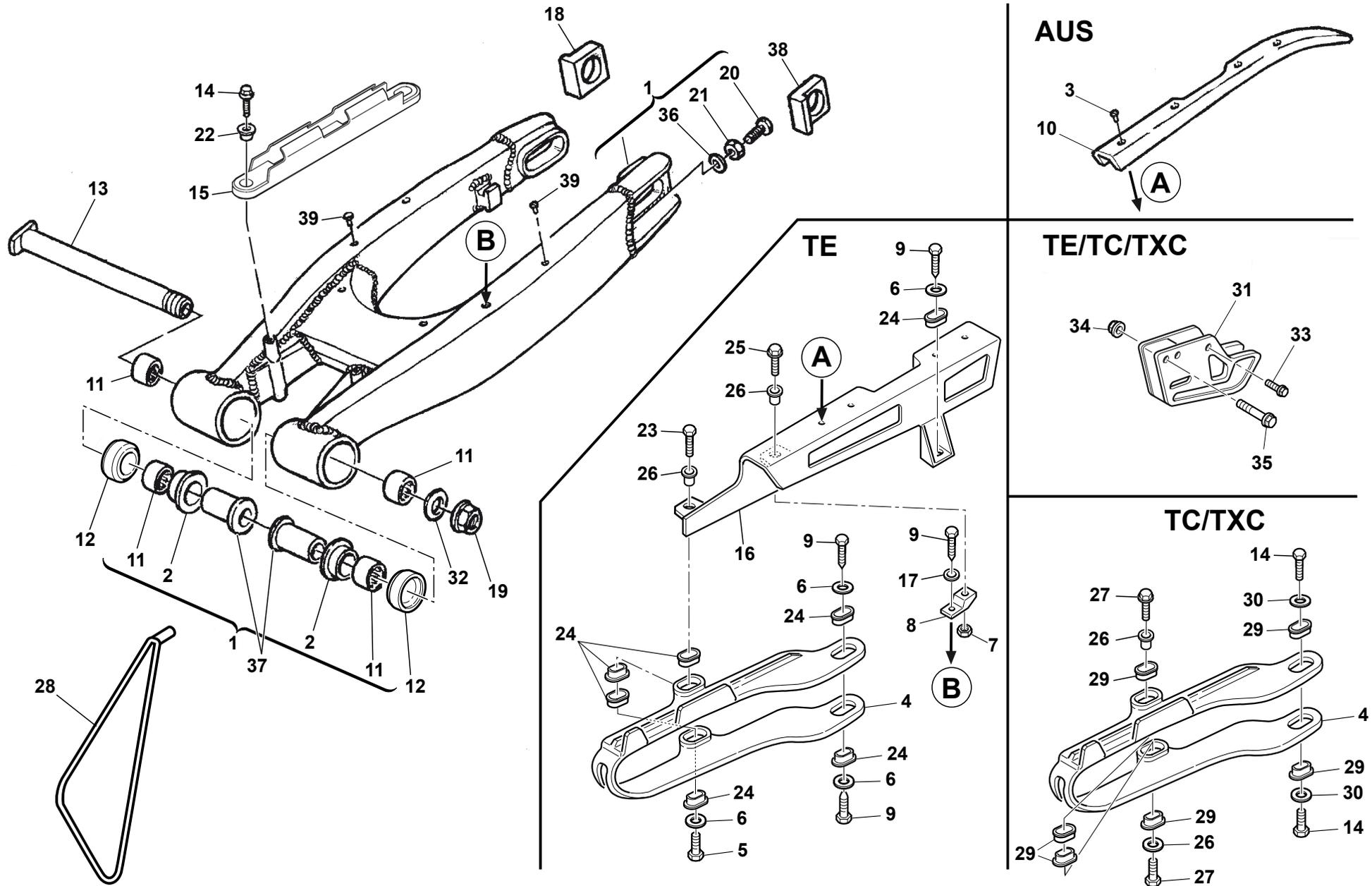



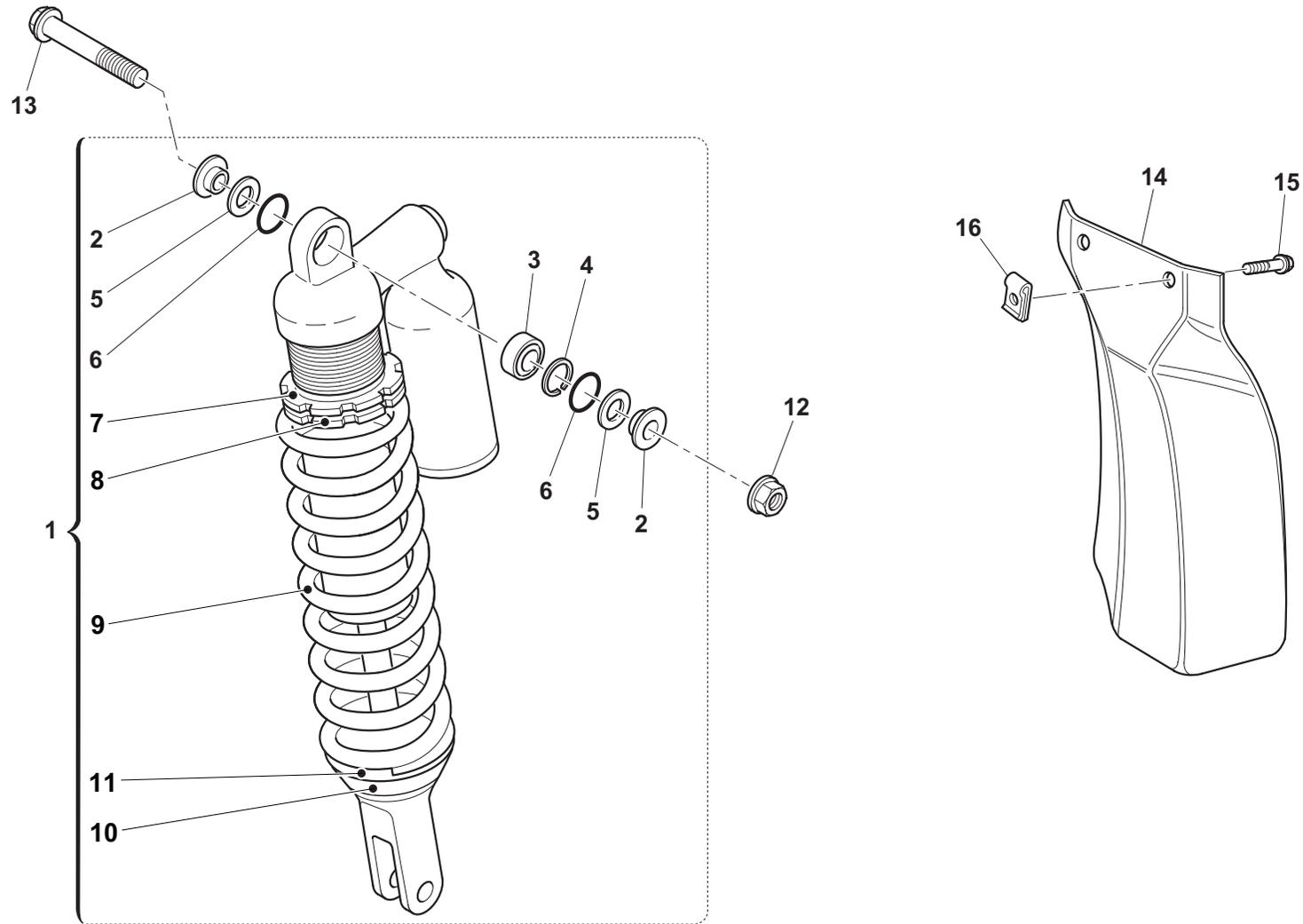





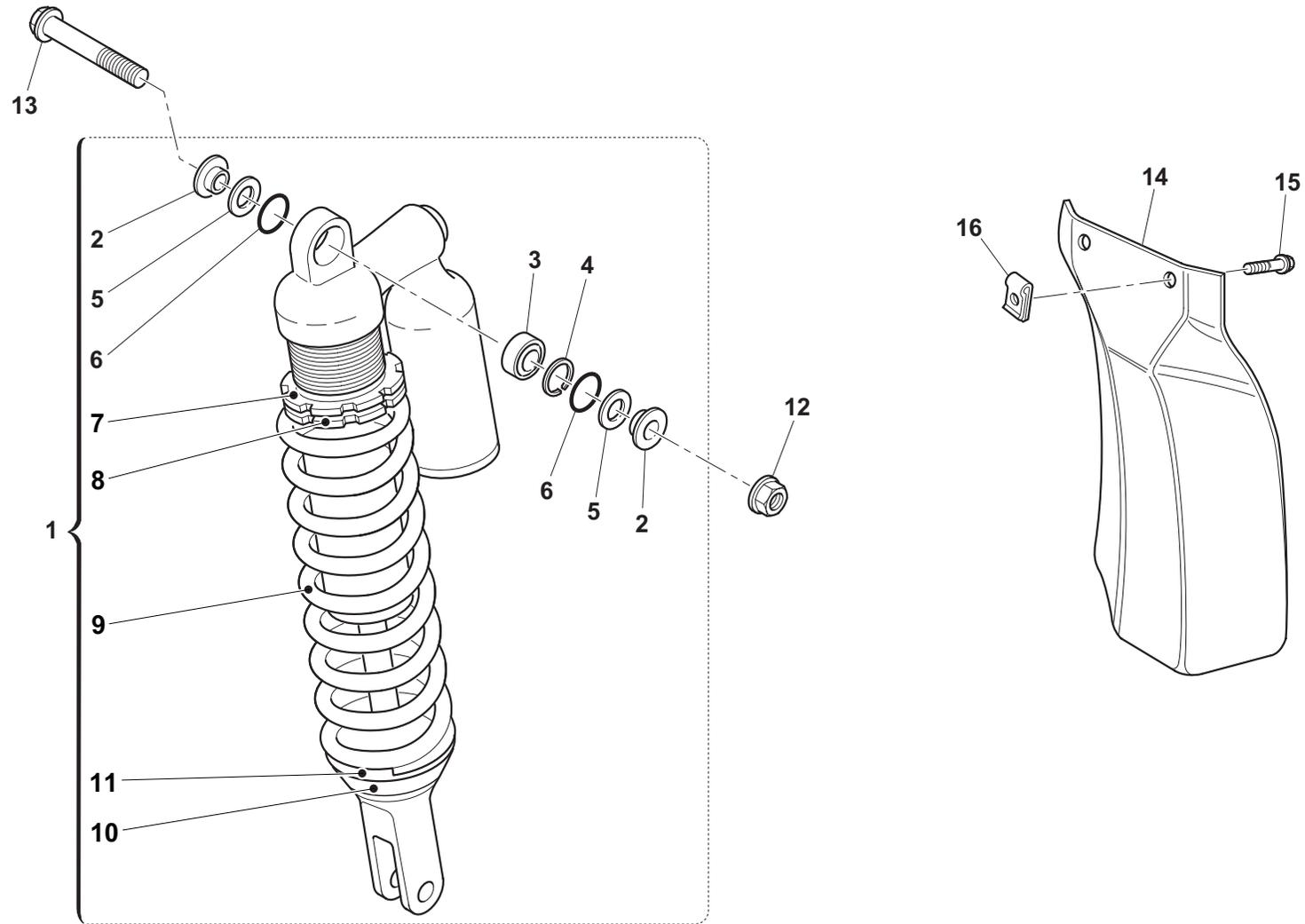

TE 250/2013  
TE 310/2013

TAVOLA - DRAWING  
TABLE - BILD - TABLA

23A

AMMORTIZZATORE POSTERIORE- REAR SUSPENSION  
SUSPENSION ARRIERE- HINTERHAUFHANGUNG  
SUSPENSION TRASERA



Note Notes Notes Marke Notas	Pos. No. Index Pos.	N. Cod. Code No. Nr. Code Code Nr N. Cod.	Q.tà Q.ty Q.te M.ge C.ad	DENOMINAZIONE	NAME	DESIGNATION	BESHREIBUNG	DENOMINACION
	1	8000 H6169	1	Ammortizzatore completo	Shock-absorber assy.	Ammortisseur compl.	Stossdampfer Kpl.	Amortiguador compl.
	2	8000 H6118	2	Coperchio	Cover	Couvercle	Deckel	Tapa
	3	8000 H6112	1	Snodo sferico	Ball joint	Joint a rotule	Kugelgelenk	Articulación esférica
	4	8000 H6113	1	Anello di fermo	Stop ring	Bague d'arrêt	Haltering	Anillo de retención
	5	8000 H6119	2	Anello di tenuta	Seal ring	Bague d'etancheite	Dichtring	Anillo de retención
	6	8000 H6120	2	Anello OR	O-Ring	Bague OR	O Ring	Anillo OR
	7	8000 H6114	1	Dado	Nut	Ecrou	Mutter	Tuerca
	8	8000 H6115	1	Guida molla	Spring seat	Siège ressort	Feder sitzring	Alojamiento resorte
	9	8000 H7713	1	Molla	Spring	Ressort	Feder	Resorte
	10	8000 H7711	1	Fondello	Bottom	Fond	Bodenscheibe	Casquillo
	11	8000 H6117	1	Guida molla	Spring seat	Siège ressort	Feder sitzring	Alojamiento resorte
	12	Z000 42022	1	Dado	Nut	Ecrou	Mutter	Tuerca
	13	Z000 62573	1	Vite	Screw	Vis	Schraube	Tornillo
	14	8000 H6429	1	Protezione ammortizzatore	Guard	Protection	Schutz	Protección
	15	8000 A8421	2	Vite flangiata M5-L8	Flange bolt M5-L8	Boulon de bride M5-L8	Flanschschraube M5-L8	Perno de reborde M5-L8
	16	U000 55134	2	Dado a graffetta	Nut	Ecrou	Mutter	Tuerca

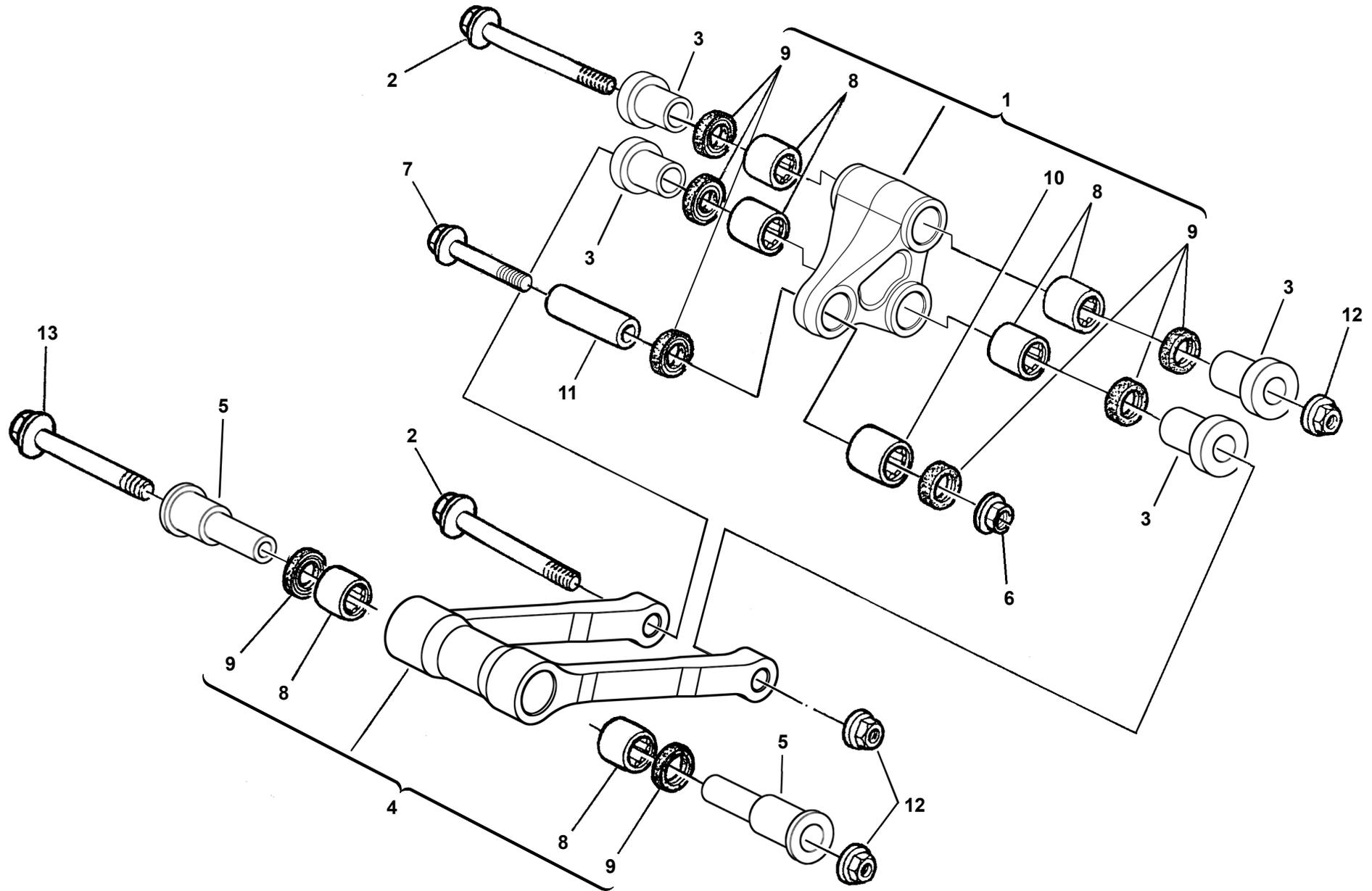



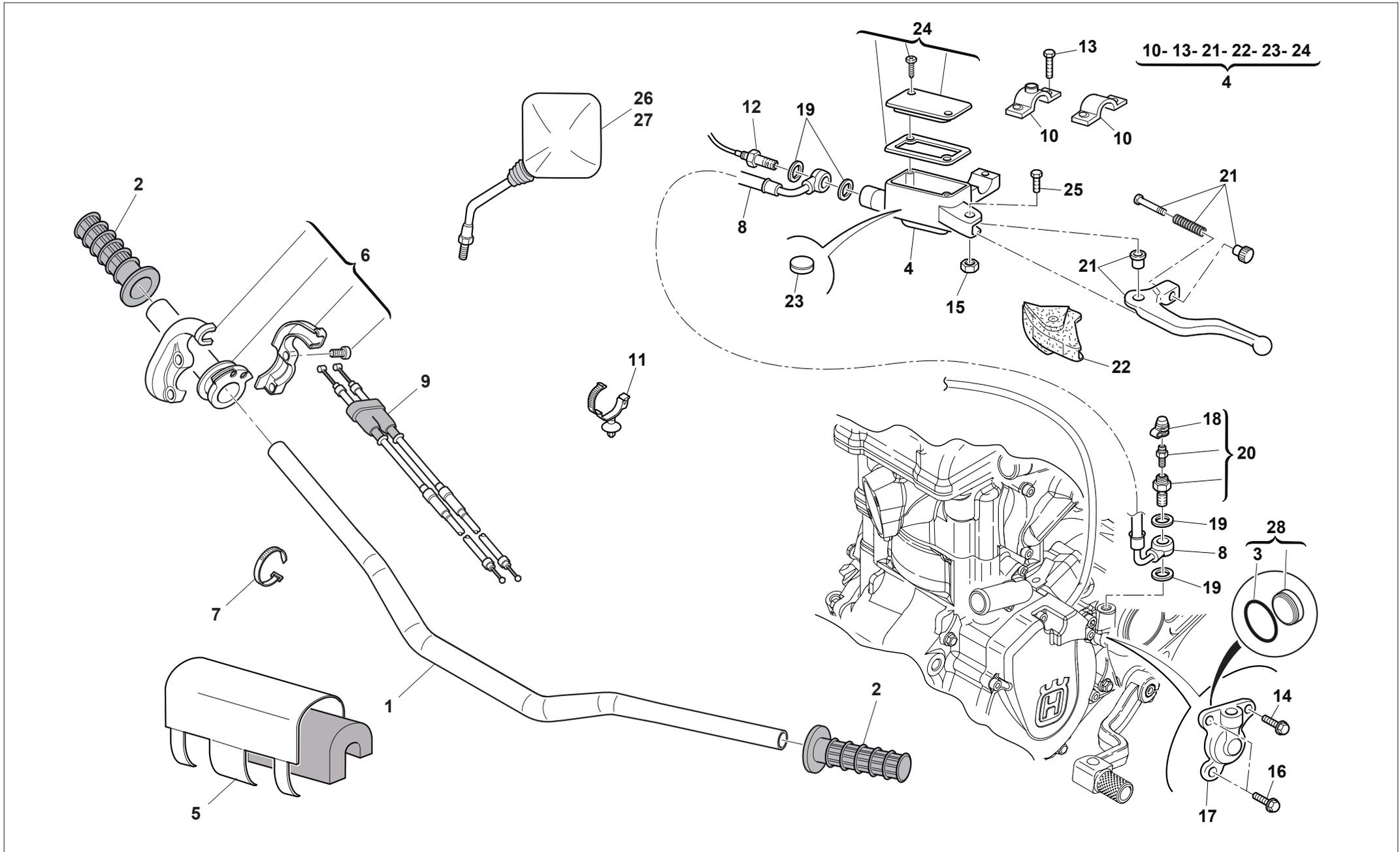

MANUBRIO E COMANDI - HANDLEBAR AND CONTROLS  
GUIDON ET COMMANDES - LENKER UND STEUERORGANE  
MANILLAR Y MANDOS

Note Notes Notes Marke Notas	Pos. No. Index Pos.	N. Cod. Code No. Nr. Code Code Nr N. Cod.	Q.tà Q.ty Q.te M.ge C.ad	DENOMINAZIONE	NAME	DESIGNATION	BESHREIBUNG	DENOMINACION
	1	8000 H6609	1	Manubrio	Hanblebar	Guidon	Lenker	Manillar
	2	8000 H6049	1	Manopole	Grip	Poignée	Griff	Manopla
	3	8000 H6010	1	OR	O-Ring	OR	O Ring	OR
KTC	4	8000 H0884	1	Ass. pompa comando frizione	Clutch control pump assy	Pompe comm. embrayage	Kupplungspumpe, Kpl.	Bomba mando embrague
WB	4	8A00 H0884	1	Ass. pompa comando frizione	Clutch control pump assy	Pompe comm. embrayage	Kupplungspumpe, Kpl.	Bomba mando embrague
	5	8538941	1	Protezione manubrio	Hanblebar guard	Protection guidon	Lenkerschutz	Protección de manillar
	6	8000 98209	1	Comando gas completo	Throttle control compl.	Commande gaz compl.	Gasgriff kpl.	Accionamiento acelerador compl.
	7	8000 71578	2	Fascetta	Clamp	Collier	Schelle	Banda
	8	8000 H0885	1	Tubo mandata olio	Oil pipe	Tuyauterie d'huile	Oelrohr	Tubo aceite
	9	8000 H6580	1	Trasmissione comando gas	Throttle wire	Fil comm. gaz	Gaszugkabel	Transmisión accionam. acelerador
BW	10	8000 H2102	1	Cavallotto	U-bolt	Cavalier	Bügelbolzen	Caballete
KTC	10	8000 H6000	1	Cavallotto	U-bolt	Cavalier	Bügelbolzen	Caballete
	11	8000 H2294	1	Fascetta	Clamp	Collier	Schelle	Banda
BWTK	12	8000 H5963	1	Idrostop	Idrostop	Idrostop	Idrostop	Idrostop
	13	Z000 62728	2	Vite	Screw	Vis	Schraube	Tornillo
	14	ZH00 67545	1	Vite flangiata	Flange bolt	Boulon de bride	Flanschenschraube	Perno de reborde
	15	8000 21810	1	Dado	Nut	Ecrou	Mutter	Tuerca
	16	Z000 62727	2	Vite	Screw	Vis	Schraube	Tornillo
	17	8000 A7048	1	Cilindro com. frizione	Clutch control cylinder	Cylindre comm. embrayage	Kupplungszyylinder	Cilindro mando embrague
	18	8000 53259	1	Parapolvere	Boots	Para-poudr	Schutzhaube	Para-polvo
	19	8000 21480	4	Rosetta	Washer	Rondelle	Scheibe	Arandela
	20	8000 A3975	1	Bocchettone spurgo completo	Bleeding union pipe	Goulotte révision curage	Reinigungstutzen	Boca de purga
	21	8000 H1982	1	Leva completa	Lever assy	Levier compl.	Hebel kpl.	Palanca compl.
	22	8000 H1983	1	Cappuccio	Cap	Capuchon	Kappe	Capuchón
	23	8000 79099	1	Antiemulsione	Antiemulsion	Antiemulsion	Emulsionwidriger	Antiemulsión
	24	8000 H1984	1	Kit tappo	Plug kit	Bouchon kit	Verschluss Gruppe	Kit tapón
	25	8000 H1985	1	Perno	Pin	Pivot	Bolzen	Perno
DWBTK	26	8A00 H1673	1	Specchietto retrov. Dx	R.H. Driving mirror	Rétroviseur D.	R. Rückspiegel	Espejo retrovisor Der.
DWBTK	27	8000 H1673	1	Specchietto retrov. Sx	L.H. Driving mirror	Rétroviseur G.	L. Rückspiegel	Espejo retrovisor Izq.
	28	8000 H6009	1	Pistoncino + OR	Piston + O-Ring	Piston + OR	Kolben + O Ring	Pistón + OR

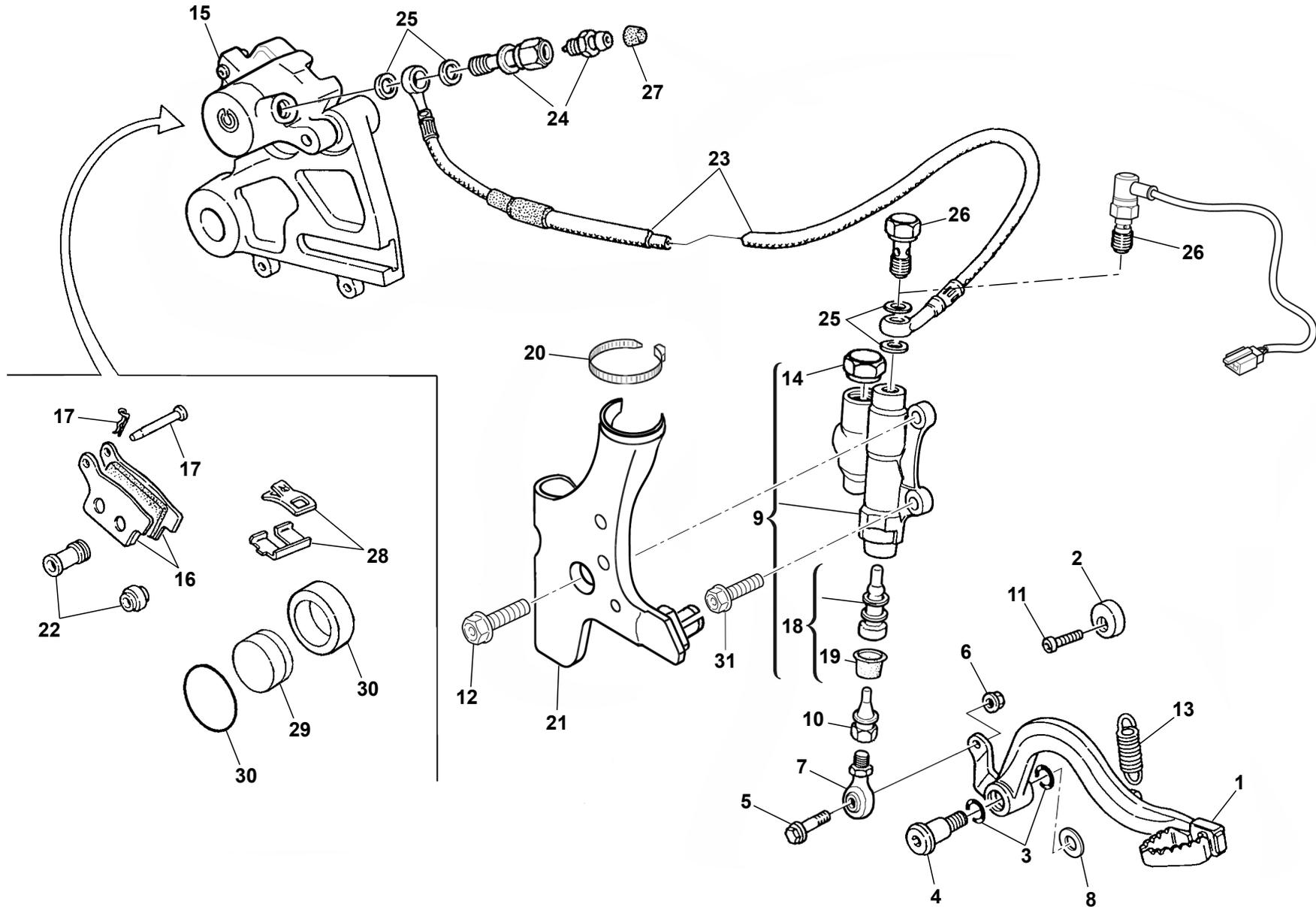



FRENO IDRAULICO POSTERIORE - REAR HYDRAULIC BRAKE  
FREIN HYDRAULIQUE ARRIERE - HINTERBREMSE  
FRENO HIDRAULICO TRASERO

Note Notes Notes Marke Notas	Pos. No. N. Index Pos.	N. Cod. Code No. Nr. Code Code Nr N. Cod.	Q.tà Q.ty Q.te M.ge C.ad	DENOMINAZIONE	NAME	DESIGNATION	BESHREIBUNG	DENOMINACION
	1	8000 A7634	1	Pedale comando freno	Brake control pedal	Pedal comm. frein	Bremspedal	Pedal accionamiento freno
	2	8A00 69125	1	Camma	Cam	Came	Nocken	Exéntrico
	3	8000 22551	2	Anello OR	O-Ring	Bague OR	O Ring	Anillo OR
	4	Y000 55902	1	Vite	Screw	Vis	Schraube	Tornillo
	5	Z000 62727	1	Vite	Screw	Vis	Schraube	Tornillo
	6	61ND 15062	1	Dado	Nut	Ecrou	Mutter	Tuerca
BKT	7	7640 10002	1	Snodo sferico Dx	Ball joint Right	Joint a rotule Droite	Kugelgelenk R.	Articulación esférica Derecha
CW	7	8A00 76055	1	Snodo sferico	Ball joint	Joint a rotule	Kugelgelenk	Articulación esférica
CT	8	8000 H1412	1	Rosetta	Washer	Rondelle	Scheibe	Arandela
	9	8000 A7633	1	Pompa comando freno	Brake pump assy	Pompe frein complet	Bremspumpe kl.	Bomba freno compl.
	10	8000 A7635	1	Puntalino	Push rod	Embout	Stösselschaft	Puntal
	11	Y000 55241	1	Vite	Screw	Vis	Schraube	Tornillo
	12	8B00A8423	1	Vite	Screw	Vis	Schraube	Tornillo
KTC	13	8000 H5148	1	Molla	Spring	Ressort	Feder	Resorte
WB	13	8A00 55903	1	Molla	Spring	Ressort	Feder	Resorte
	14	8000 A9447	1	Tappo	Plug	Bouchon	Verschluss	Tapón
	15	8000 A4291	1	Pinza freno completa	Brake caliper assy	Pince de frein, compl.	Bremszange, Kpl.	Pinza freno compl.
	16	8000 A2790	1	Coppia pastiglie	Pads pair	Paire plaquettes	Bremsbelagpaar	Pareja pastillas
	17	8000 A2791	1	Perno	Pin	Pivot	Bolzen	Perno
	18	8000 A9448	1	Flottante	Plunger	Piston	Kolben	Pistón
	19	8000 A9449	1	Cuffia	Boots	Poussiers	Haube	Gorro
	20	8000 56444	1	Fascetta	Clamp	Collier	Schelle	Banda
	21	8000 H3434	1	Protezione telaio Dx	R.H. frame guard	Protection chassis D.	Rahmenschutz Rechts	Protección bastidor derecha
	22	8000 79066	1	Cuffie	Boots	Poussiers	Haube	Gorro
	23	8000 B1162	1	Tubo freno posteriore	Rear brake tube	Tuyau du frein AR.	Hintere Bremsleitung	Tubo freno trasero
	24	8000 A3975	1	Bocchettone spurgo completo	Bleeding union pipe	Goulotte révision curage	Reinigungstutzen	Boca de purga
	25	8000 90485	4	Rosetta	Washer	Rondelle	Scheibe	Arandela
WB	26	8000 94849	1	Interruttore stop posteriore	Stop switch	Interrupteur stop	Stopschalter	Interruptor stop trasero
KTC	26	U000 57155	1	Vite	Screw	Vis	Schraube	Tornillo
	27	8000 53259	1	Parapolvere	Boots	Para-poudr	Schutzhaube	Para-polvo
	28	8000 A2792	1	Molla-lamierino	Spring-steel clip	Ressort	Feder	Rresorte
	29	8000 A2793	1	Pistone	Piston	Piston	Kolben	Pistón
	30	8000 A2794	1	Kit guarnizioni pistone	Gasket piston, kit	Kit garniture piston	Kit Kolbendichtung	Kit juntas pistón





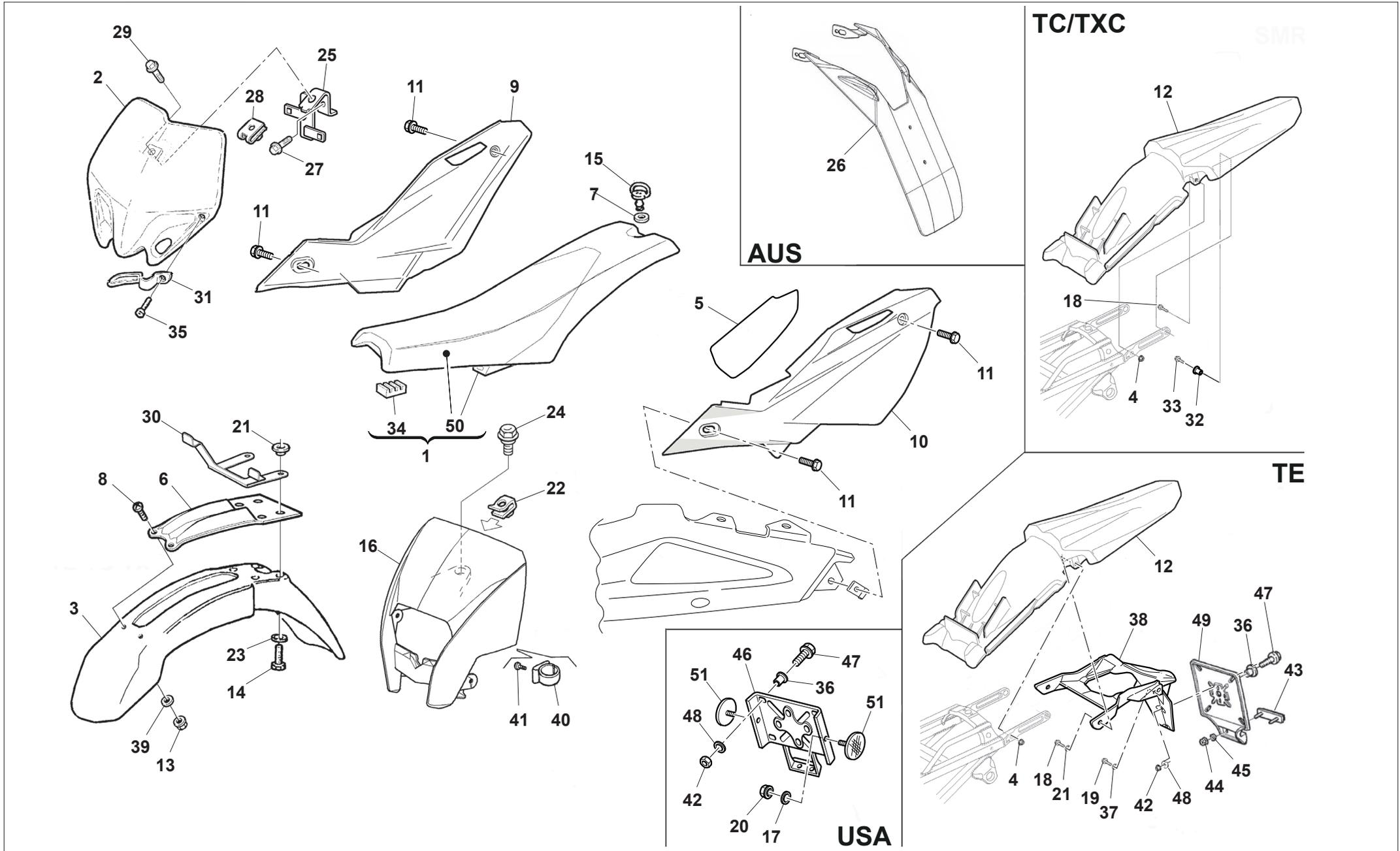

PANNELLI, PARAFANGHI, SELLA - PANEL, FENDERS, SEAT  
PANNEAU, GARDE-BOUES, SIEGE - STREIFEN, KOTFLUGEL, SATTEL  
PANELO, GUARDABARROS, SILLIN

Note Notes Notas	Pos. No. Index Pos.	N. Cod. Code No. Nr. Code Code Nr N. Cod.	Q.tà Q.ty Q.te M.ge C.ad	DENOMINAZIONE	NAME	DESIGNATION	BESHREIBUNG	DENOMINACION
	1	8000 B0170	1	Sella	Seat	Siège	Sattel	Sillín
KTC	2	80C0 A4216	1	Portanumero	Front number holder	Portenumero	Schlüsselring	Portanumero
	3	80C0 H0878	1	Parafango anteriore BIANCO	Front mudguard	Garde-boue avant	Vord. Kotfluegel	Guarda-barros del.
	4	Z000 44240	2	Dado	Nut	Ecrou	Mutter	Tuerca
	5	8000 B0167	1	Protezione paracalore	Heat guard	Protection pare-chaueur	Hizeschutz	Protección paracalor
	6	80A0 A4198	1	Rinforzo per parafango	Fender holder	Soutie pour garde-boue	Kotfluegel-support	Soporte por guardabarros del.
	7	8000 69149	1	Rosetta	Washer	Rondelle	Scheibe	Arandela
	8	Z000 65535	2	Vite	Screw	Vis	Schraube	Tornillo
	9	8538412	1	Pannello destro con adesivo BIANCO	R.H. panel with adhesive (color code G) White	Panneau, D. avec adhésif (code couleur G) Blanc	Streifen. R. mit klebe (Code Farbe G) Weiss	Panel Der. con pagatina (código color G) Blanco
	10	8538413	1	Pannello sinistro con adesivo BIANCO	L.H. panel with adhesive (color code G) White	Panneau, G. avec adhésif (code couleur G) Blanc	Streifen. L. mit klebe (Code Farbe G) Weiss	Panel Izq. con pagatina (código color G) Blanco
	11	8B00 A8421	4	Vite	Screw	Vis	Schraube	Tornillo
KTC	12	80B0 B0162	1	Parafango posteriore BIANCO	Rear mudguard WHITE	Garde-boue arrière BLANC	Hint. Kotfluegel WEISS	Guarda-barros trasero BLANCO
BW	12	80B0 H1404	1	Parafango posteriore BIANCO	Rear mudguard WHITE	Garde-boue arrière BLANC	Hint. Kotfluegel WEISS	Guarda-barros trasero BLANCO
	13	Z000 61355	2	Dado	Nut	Ecrou	Mutter	Tuerca
	14	Z000 62729	4	Vite	Screw	Vis	Schraube	Tornillo
	15	8000 H1917	1	Perno	Pin	Pivot	Bolzen	Perno
BW	16	80C0 H0198	1	Cupolino	Front fairing (color code G) White	Carenage (code couleur G) Blanc	Verkleidung (Code Farbe G) Weiss	Cúpula (código color G) Blanco
BWU	17	62ND 15548	2	Rosetta	Washer	Rondelle	Scheibe	Arandela
	18	ZPA0 67545	2	Vite	Screw	Vis	Schraube	Tornillo
BW	19	Z000 62727	2	Vite	Screw	Vis	Schraube	Tornillo
BWU	20	Z000 56443	2	Dado	Nut	Ecrou	Mutter	Tuerca
	21	ZA00 69429	2	Bussola	Bushing	Douille	Buchse	Buje
BW	22	U000 55134	1	Dado a graffetta	Nut	Ecrou	Mutter	Tuerca
	23	Z000 48814	4	Rosetta	Washer	Rondelle	Scheibe	Arandela
BW	24	8B00 A8421	1	Vite	Screw	Vis	Schraube	Tornillo
KTC	25	8000 H7407	1	Attacco portanumero completo	Number holder plate assy	Plaque portenumero complet	Platte Komplet	Placa portanumero completa
BWG	26	8000 H1518	1	Prolunga paraf. post.	Rear mudguard extension	Extension garde-boue arriere	Ausdehnung	Prolonga guarda-barros tras.
KTC	27	ZE00 67997	1	Vite	Screw	Vis	Schraube	Tornillo
KTC	28	U000 46893	1	Dado a graffetta	Nut	Ecrou	Mutter	Tuerca
KTC	29	Z000 62726	1	Vite	Screw	Vis	Schraube	Tornillo
	30	8000 H3006	1	Attacco portanumero	Spacer	Entretoise	Distanzstück	Separador
KTC	31	80A0 A4610	1	Guidafilo	Cable guide	Passe-câble	Kabelführung	Prensa-cable
KTC	32	Z000 69429	2	Bussola	Bushing	Douille	Buchse	Buje

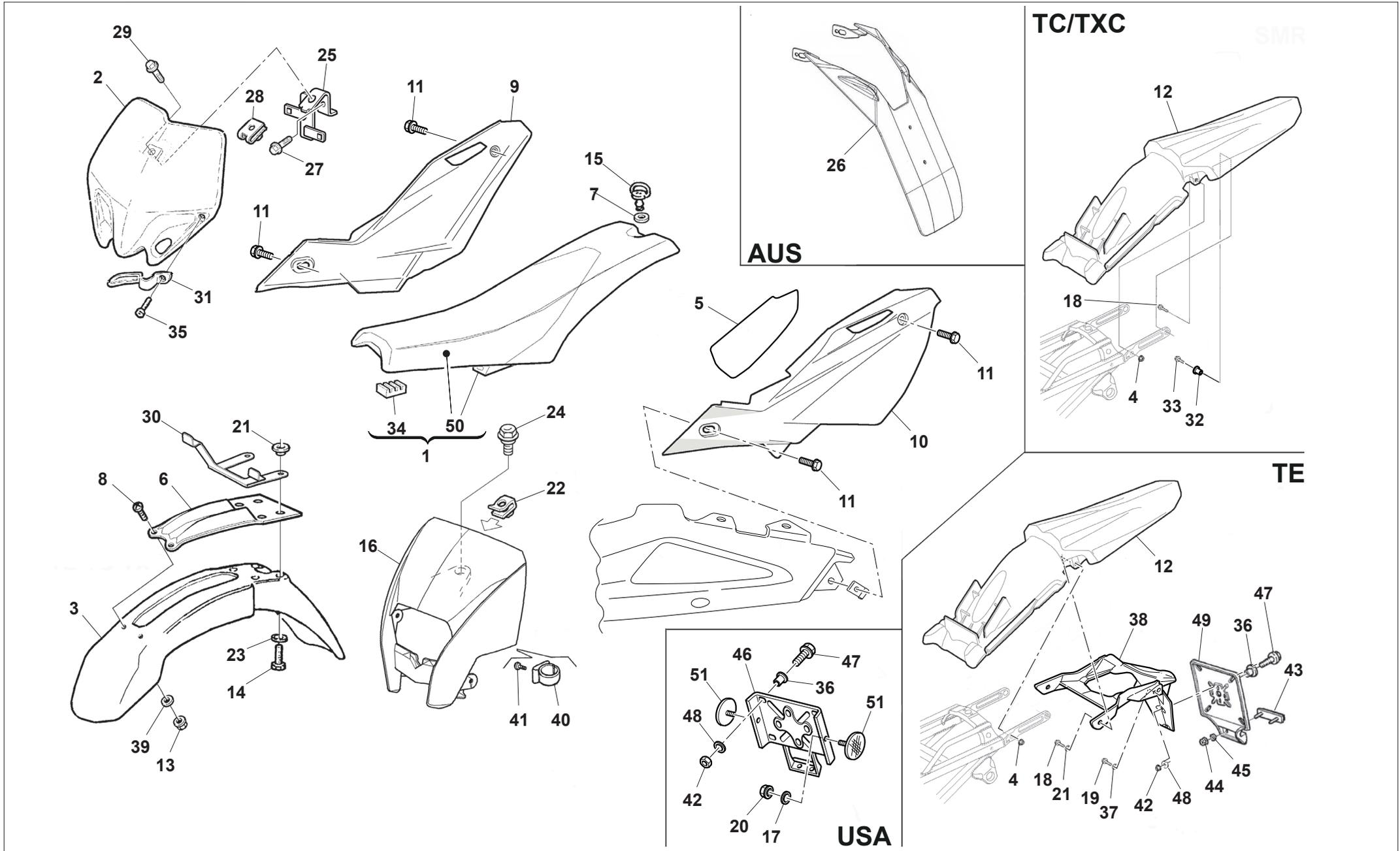



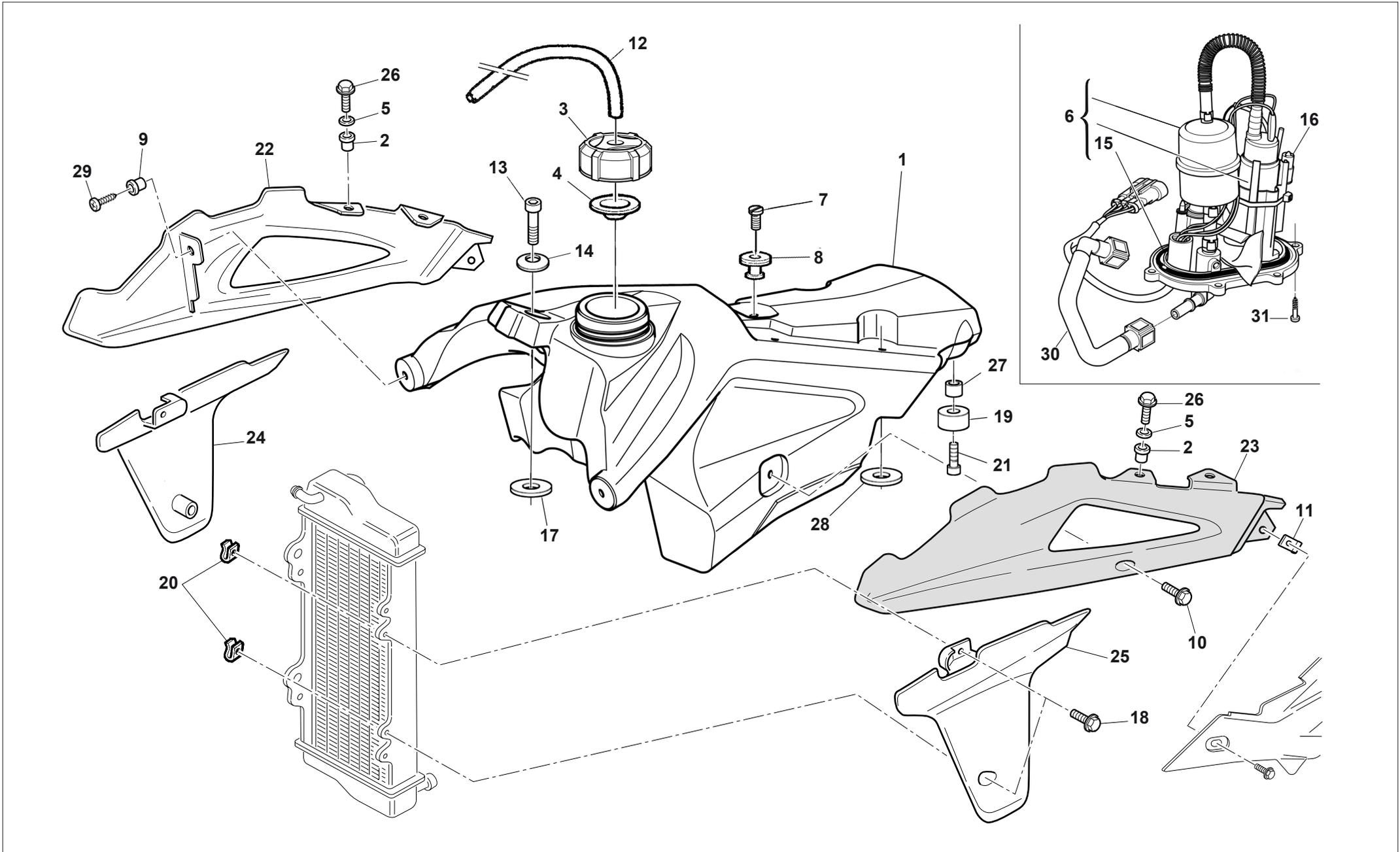



**SERBATOIO CARBURANTE, CONVOGLIATORI - GAS TANK, PANEL -  
RESERVOIR CARBURANT, FLANC - KRAFTSTOFFBEHALTER, FLANKE -  
DEPOSITO GASOLINA, LATERAL**
TAVOLA - DRAWING  
TABLE - BILD - TABLA

28

Note Notes Marke Notas	Pos. No. Index Pos.	N. Cod. Code No. Nr. Code Code Nr N. Cod.	Q.tà Q.ty Q.te M.ge C.ad	DENOMINAZIONE	NAME	DESIGNATION	BESHREIBUNG	DENOMINACION
	1	80A0 H1496	1	Serbatoio carburante	Fuel tank	Réservoir essence	Kraftstoffbehälter	Depósito gasolina
	2	8000 69282	4	Bussola	Bushing	Douille	Buchse	Buje
	3	8000 B1057	1	Tappo serbatoio	Tank cap	Bouchon reservoir	Behälterstöpsel	Tapón depósito
	4	8000 A4562	1	Guarnizione	Gasket	Garniture	Dichtung	Junta
	5	Z000 48814	4	Rosetta	Washer	Rondelle	Scheibe	Arandela
	6	8000 H2930	1	Pompa benzina	Fuel pump	Pompe carburant	Benzinpumpe	Bomba gasolina
	7	60ND 04134	1	Vite	Screw	Vis	Schraube	Tornillo
	8	8000 66238	1	Distanziale	Spacer	Entretoise	Distanzstück	Separador
	9	8000 H3017	2	Bussola	Bushing	Douille	Buchse	Buje
	10	8000 A8421	2	Vite flangiata M5-L8	Flange bolt M5-L8	Boulon de bride M5-L8	Flanschschraube M5-L8	Perno de reborde M5-L8
	11	U000 55134	2	Dado a graffetta	Nut	Ecrou	Mutter	Tuerca
	12	9472 00035	1	Tubo	Pipe	Tuyau	Rohr	Tubo
	13	60ND 07335	1	Vite	Screw	Vis	Schraube	Tornillo
	14	8000 A5678	1	Rosetta	Washer	Rondelle	Scheibe	Arandela
	15	8000 H0184	1	Guarnizione	Gasket	Garniture	Dichtung	Junta
	16	8537276	1	Sensore riserva con cablaggio	Reserve sensor with cable	Réserve du capteur avec cable	Reserve-Sensor mit Kabel	Sensòr de repuesto con cable
	17	8000 61362	1	Rosetta	Washer	Rondelle	Scheibe	Arandela
	18	8A00 A8421	4	Vite	Screw	Vis	Schraube	Tornillo
	19	8000 B0647	2	Tampone	Pad	Tampon	Stopfen	Tampón
	20	8000 H2168	4	Dado a graffetta	Nut	Ecrou	Mutter	Tuerca
	21	Z000 37745	2	Vite	Screw	Vis	Schraube	Tornillo
	22	8538414	1	Convogliatore Dx con adesivo	Right side panel with adhesive	Flanc Droite avec adhésif	Flanke R. mit klebe	Lateral Derecha con pegatina
	23	8538415	1	Convogliatore Sx con adesivo	Left side panel with adhesive	Flanc Gouche avec adhésif	Flanke L. mit klebe	Lateral Izquierda con pegatina
	24	8000 H0256	1	Protezione Dx	R.H. protection	Protection D.	Schutz Rechte	Protección der.
	25	8000 H0255	1	Protezione Sx	L.H. protection	Protection G.	Schutz Linke	Protección izquierda
	26	Z000 67997	4	Vite	Screw	Vis	Schraube	Tornillo
	27	8B00 A0680	2	Distanziale	Spacer	Entretoise	Distanzstück	Separador
	28	8A00 61362	2	Rosetta	Washer	Rondelle	Scheibe	Arandela
	29	Z000 37745	2	Vite	Screw	Vis	Schraube	Tornillo
	30	8000 B0250	1	Condotto benzina	Pipe	Tuyau	Rohr	Tubo
	31	ZA00 67997	6	Vite	Screw	Vis	Schraube	Tornillo

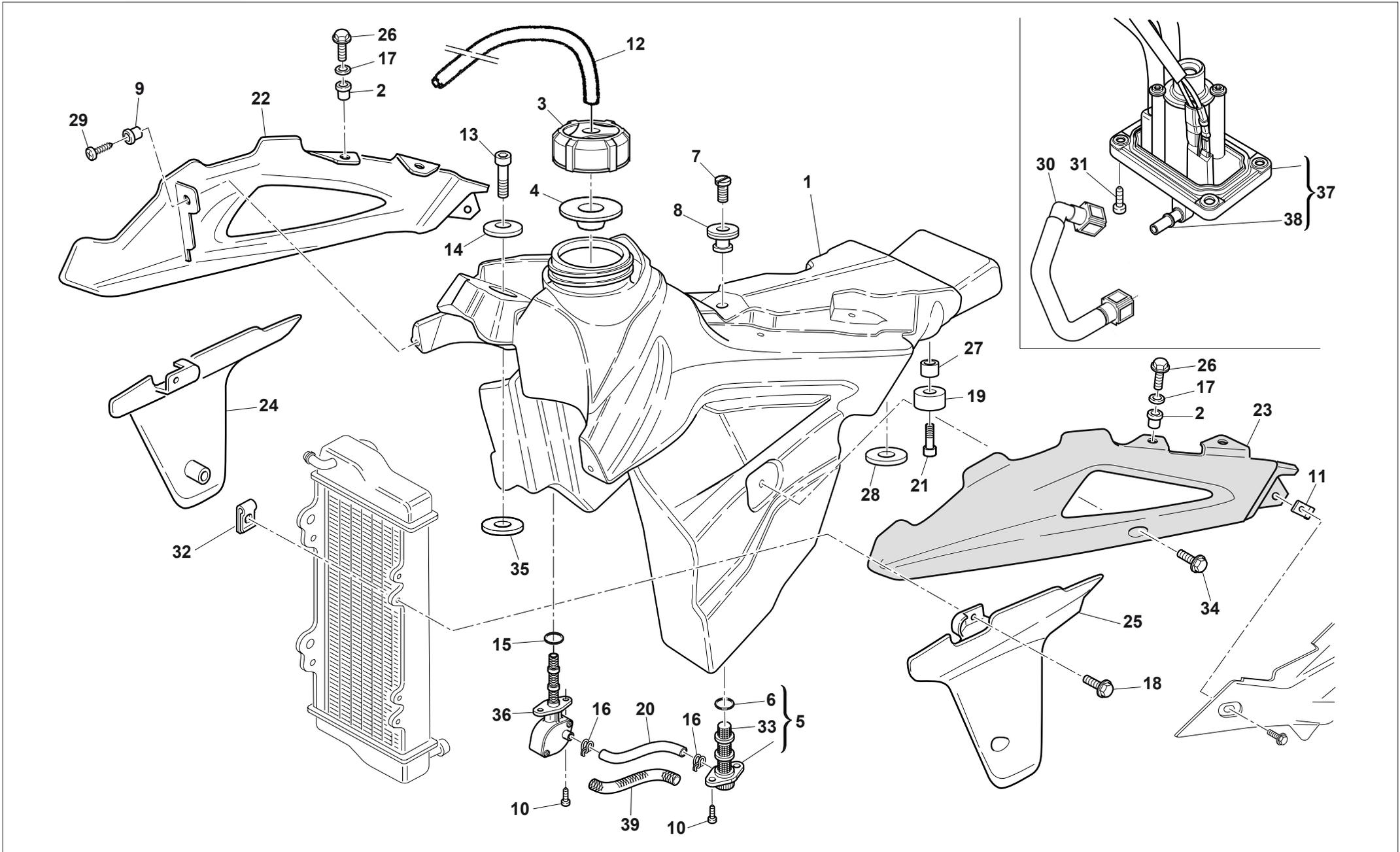

TE-TXC 250/2013  
TE-TXC 310/2013

TAVOLA - DRAWING  
TABLE - BILD - TABLA

28A

SERBATOIO CARBURANTE, CONVOGLIATORI - GAS TANK, PANEL -  
RESERVOIR CARBURANT, FLANC - KRAFTSTOFFBEHALTER, FLANKE -  
DEPOSITO GASOLINA, LATERAL



Note Notes Notes Marke Notas	Pos. No. N. Index Pos.	N. Cod. Code No. Nr. Code Code Nr N. Cod.	Q.tà Q.ty Q. M.ge C.ad	DENOMINAZIONE	NAME	DESIGNATION	BESHREIBUNG	DENOMINACION
X	1	8000 H3345	1	Serbatoio carburante	Fuel tank	Réservoir essence	Kraftstoffbehälter	Depósito gasolina
U	1	8000 H3346	1	Serbatoio carburante	Fuel tank	Réservoir essence	Kraftstoffbehälter	Depósito gasolina
	2	ZC00 69429	4	Bussola	Bushing	Douille	Buchse	Buje
	3	8000 B1057	1	Tappo serbatoio	Tank cap	Bouchon reservoir	Behälterstöpsel	Tapón depósito
	4	8000 A4562	1	Guarnizione	Gasket	Garniture	Dichtung	Junta
	5	8000 67440	1	Rubinetto benzina	Fuel cock	Robinet de combustible	Kraftstoffhahn	Llave de paso gasolina
	6	8000 A8278	1	Anello OR	O-Ring	Bague OR	O Ring	Anillo OR
	7	60ND 04134	1	Vite	Screw	Vis	Schraube	Tornillo
	8	8000 66238	1	Distanziale	Spacer	Entretoise	Distanzstück	Separador
	9	ZA00 69429	2	Bussola	Bushing	Douille	Buchse	Buje
U	10	8BA0 61070	4	Vite	Screw	Vis	Schraube	Tornillo
X	10	Z000 37745	4	Vite	Screw	Vis	Schraube	Tornillo
	11	U000 55134	2	Dado a graffetta	Nut	Ecrou	Mutter	Tuerca
	12	9472 00035	1	Tubo	Pipe	Tuyau	Rohr	Tubo
	13	60ND 07335	1	Vite	Screw	Vis	Schraube	Tornillo
	14	8000 A5678	1	Rosetta	Washer	Rondelle	Scheibe	Arandela
	15	8000 88240	1	Guarnizione	Gasket	Garniture	Dichtung	Junta
	16	80A0 42349	2	Fascetta	Clamp	Collier	Schelle	Banda
	17	Z000 48814	4	Rosetta	Washer	Rondelle	Scheibe	Arandela
	18	8A00 A8421	4	Vite	Screw	Vis	Schraube	Tornillo
	19	8000 B0647	1	Tampone	Pad	Tampon	Stopfen	Tampón
	20	9472 00074	1	Condotto benzina	Pipe	Tuyau	Rohr	Tubo
X	21	Z000 37745	1	Vite	Screw	Vis	Schraube	Tornillo
U	21	ZB00 61070	1	Vite	Screw	Vis	Schraube	Tornillo
	22	8538414	1	Convogliatore Dx con adesivo	Right side panel with adhesive	Flanc Droite avec adhésif	Flanke R. mit klebe	Lateral Derecha con pegatina
	23	8538415	1	Convogliatore Sx con adesivo	Left side panel with adhesive	Flanc Gouche avec adhésif	Flanke L. mit klebe	Lateral Izquierda con pegatina
	24	8000 H0256	1	Protezione Dx	R.H. protection	Protection D.	Schutz Rechte	Protección der.
	25	8000 H0255	1	Protezione Sx	L.H. protection	Protection G.	Schutz Linke	Protección izquierda
	26	Z000 62729	4	Vite	Screw	Vis	Schraube	Tornillo
	27	8B00 A0680	1	Distanziale	Spacer	Entretoise	Distanzstück	Separador
	28	8A00 61362	2	Rosetta	Washer	Rondelle	Scheibe	Arandela
	29	Z000 62728	2	Vite	Screw	Vis	Schraube	Tornillo
X	30	8000 B0250	1	Condotto benzina	Pipe	Tuyau	Rohr	Tubo

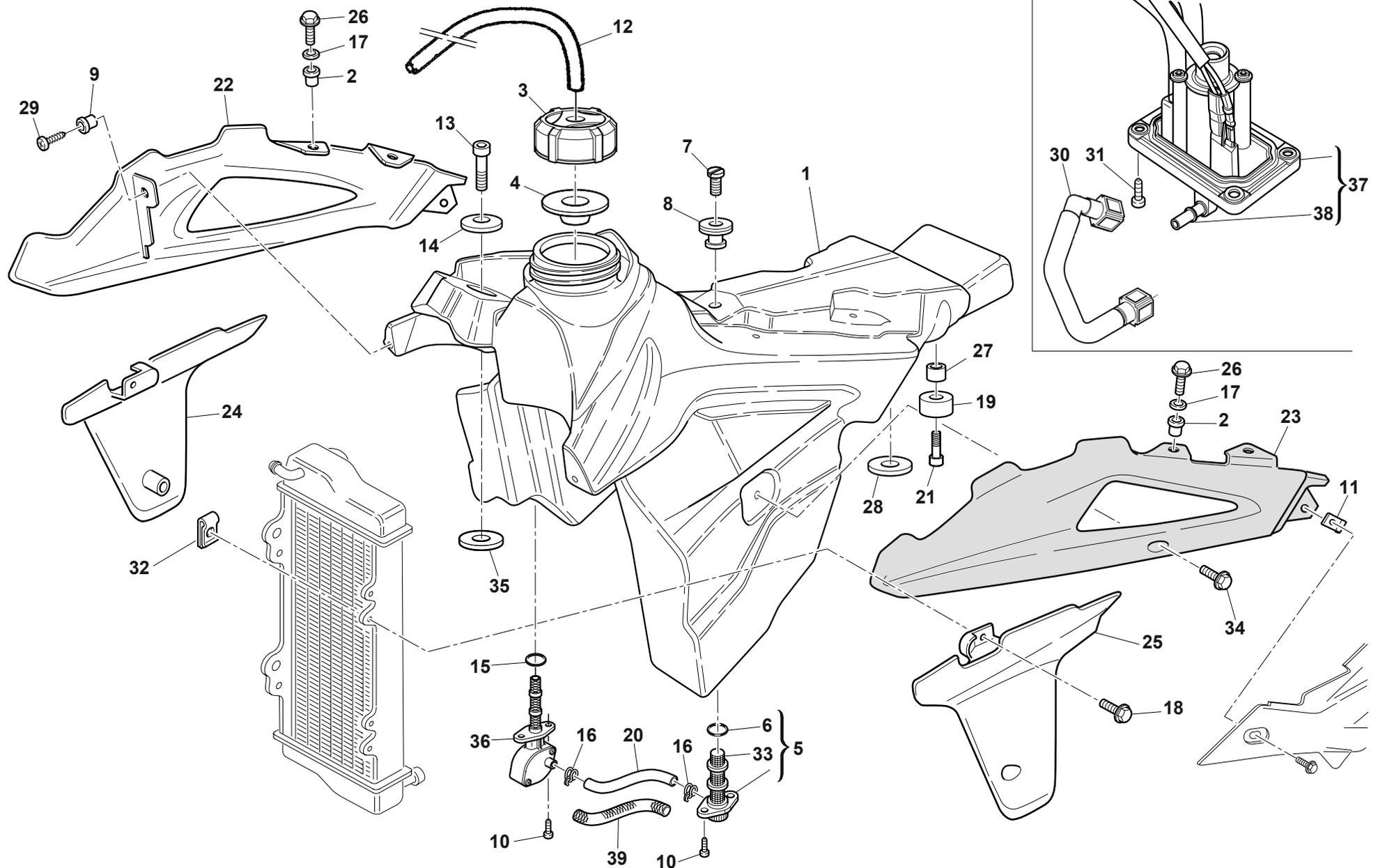





SCARICO - EXHAUST SYSTEM  
TUYAU D'ÉCHAPPEMENT - AUSPUFFROHR  
TUBO DE ESCAPE

Note Notes Notes Marke Notas	Pos. No. N. Index Pos.	N. Cod. Code No. Nr. Code Code Nr N. Cod.	Q.tà Q.ty Q.te M.ge C.ad	DENOMINAZIONE	NAME	DESIGNATION	BESHREIBUNG	DENOMINACION
TW	1	8538792	1	Tubo di scarico	Exhaust pipe	Tuyau d'échapp.	Auspuffrohr	Tubo de escape
KB	1	8538793	1	Tubo di scarico	Exhaust pipe	Tuyau d'échapp.	Auspuffrohr	Tubo de escape
KT	2	8000 H7310	1	Silenziatore	Silencer	Silencieux	Schalldämpfer	Silenciador
WB	2	8538529	1	Silenziatore	Silencer	Silencieux	Schalldämpfer	Silenciador
	3	8000 H7308	2	Molla	Spring	Ressort	Feder	Resorte
	4	8000 H7316	1	Protezione	Guard	Protection	Schutz	Protección
	5	Z000 44240	2	Dado	Nut	Ecrou	Mutter	Tuerca
	6	8000 35112	4	Rosetta	Washer	Rondelle	Scheibe	Arandela
	7	Z000 69056	2	Vite flangiata	Flange bolt	Boulon de bride	Flanschschraube	Perno de reborde
	8	ZA00 67545	2	Vite	Screw	Vis	Schraube	Tornillo
	9	Z000 22271	2	Rosetta	Washer	Rondelle	Scheibe	Arandela
	10	8000 B0263	2	Distanziale	Spacer	Entretoise	Distanzstück	Separador
	11	8000 H0064	1	Gommino	Rubber pad	Pièce caoutchouc	Gummistück	Junta de goma
WB	12	8C00 A7729	2	Distanziale	Spacer	Entretoise	Distanzstück	Separador
	13	8000 H0084	1	Gommino	Rubber pad	Pièce caoutchouc	Gummistück	Junta de goma
WB	14	8000 H6698	1	Dispositivo limitazione fonometrica	Noise reducyion device	Reducteur de bruit	Dämppaket	Reductor de ruido
BU	14	8000 H6855	1	Spark arrester	Spark arrester	Spark arrester	Spark arrester	Spark arrester
DWBTK	14	8000 H7303	1	Dispositivo limitazione fonometrica	Noise reducyion device	Reducteur de bruit	Dämppaket	Reductor de ruido
D	15	8000 B1305	1	Anello elastico	Snap ring	Circlip	Sprengring	Anillo elástico
	16	8000 B0269	1	Protezione	Guard	Protection	Schutz	Protección
	17	8A00 H7088	1	Guarnizione	Gasket	Garniture	Dichtung	Junta
WB	18	8000 H3653	1	Sonda Lambda	Lambda sensor	Sonde lambda	Lambdasonde	Sonda lambda
D	19	8000 A7749	1	Guarnizione	Gasket	Garniture	Dichtung	Junta
DBKWTW	20	8538964	1	Tappo	Plug	Bouchon	Verschluss	Tapón
DBKWTW	21	8000 H6378	1	Connettore per sonda lambda	Lambda sensor connector	Connecteur pour sonde lambda	Lambdasondekonnektor	Conectòr por sonda lambda
	22	Z000 55699	4	Vite	Screw	Vis	Schraube	Tornillo
	23	62ND 15504	4	Rosetta	Washer	Rondelle	Scheibe	Arandela
	24	62ND 15778	4	Rosetta	Washer	Rondelle	Scheibe	Arandela
	25	8000 H7309	1	Vite	Screw	Vis	Schraube	Tornillo
WB	26	8000 H2084	1	Catalizzatore	Catalyst	Catalyseur	Katalysator	Catalizador

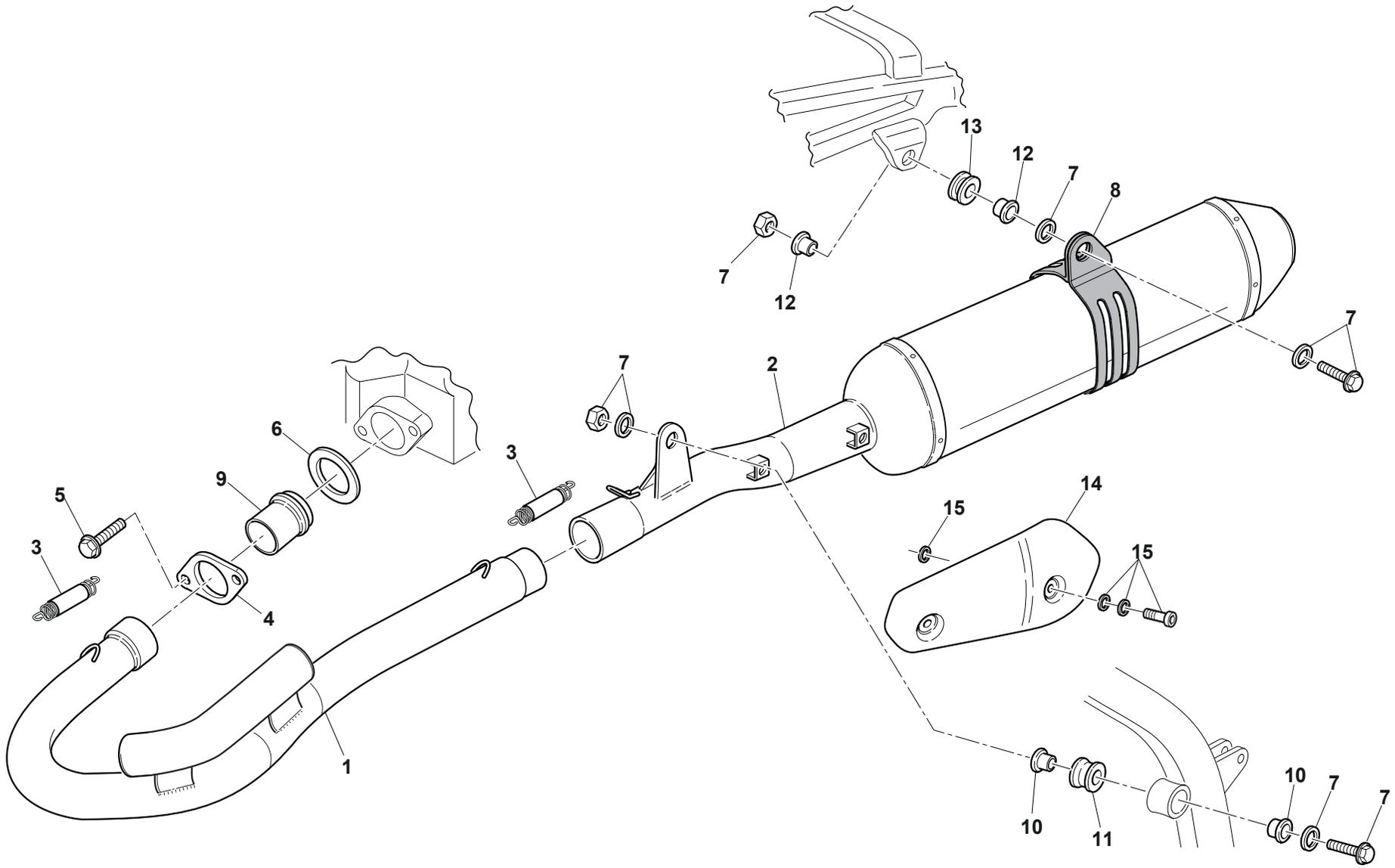





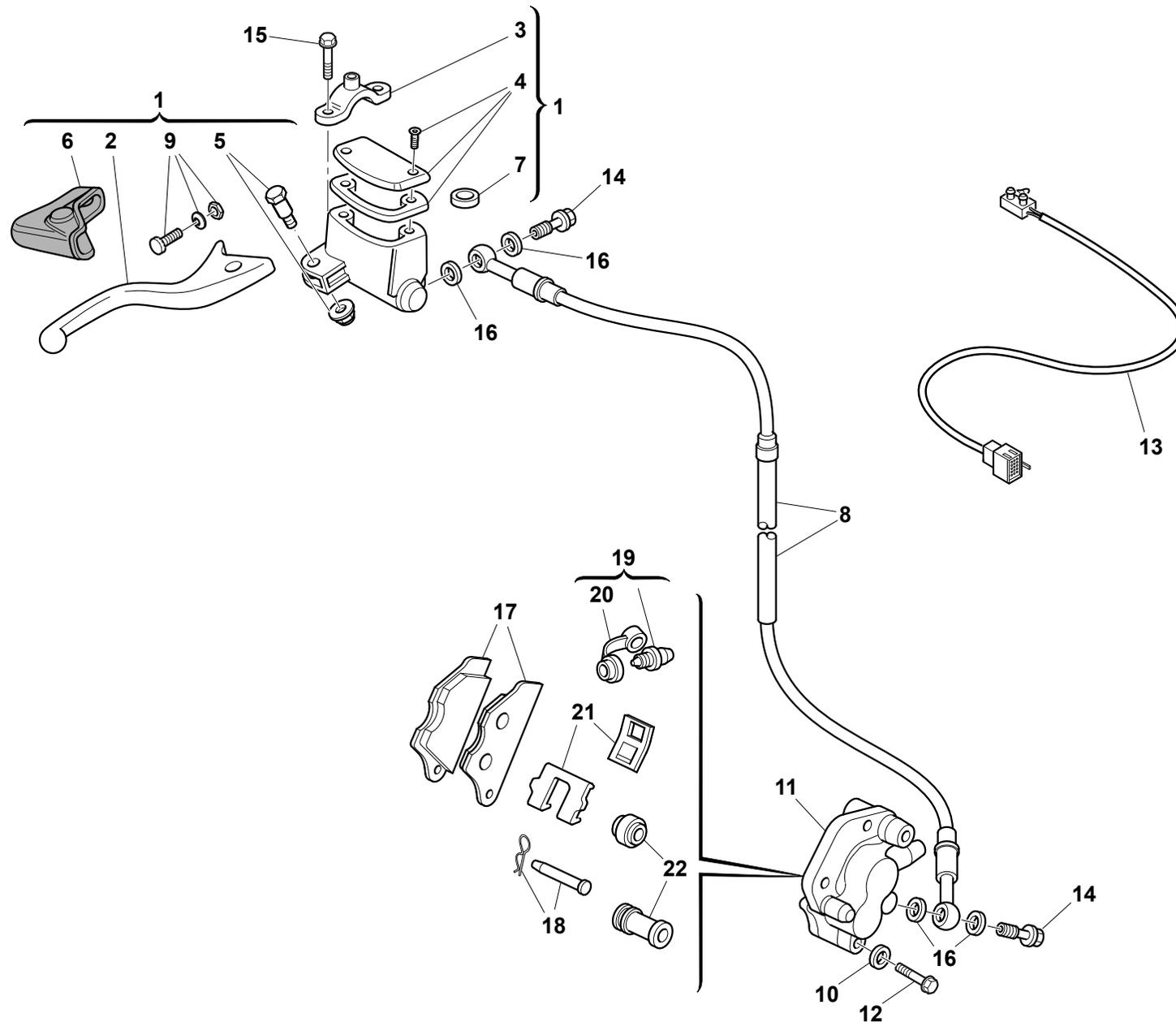

FRENO IDRAULICO ANTERIORE - FRONT HYDRAULIC BRAKE  
FREIN HYDRAULIQUE AVANT - VORDERBREMSE  
FRENO HIDRAULICO DELANTERO



Note Notes Notes Marke Notas	Pos. No. N. Index Pos.	N. Cod. Code No. Nr. Code Code Nr N. Cod.	Q.tà Q.ty Q.te M.ge C.ad	DENOMINAZIONE	NAME	DESIGNATION	BESHREIBUNG	DENOMINACION
KTC	1	8000 A9347	1	Pompa comando freno ant.	Brake pump	Pompe frein	Bremspumpe	Bomba freno
WB	1	8000 A9348	1	Pompa comando freno ant.	Brake pump	Pompe frein	Bremspumpe	Bomba freno
BW	2	8000 A4564	1	Leva	Lever	Levier	Hebel	Palanca
KTC	2	8000 A9351	1	Leva	Lever	Levier	Hebel	Palanca
KTC	3	8000 A4565	1	Cavalotto	U-bolt	Cavalier	Bügelbolzen	Caballete
BW	3	8000 A4568	1	Cavalotto	U-bolt	Cavalier	Bügelbolzen	Caballete
	4	8000 94126	1	Kit tappo	Plug kit	Bouchon kit	Verschluss Gruppe	Kit tapón
	5	8000 94127	1	Perno	Pin	Pivot	Bolzen	Perno
	6	8000 94128	1	Cappuccio	Cap	Capuchon	Kappe	Capuchón
	7	8000 79099	1	Antiemulsione	Antiemulsion	Antiemulsion	Emulsionwidriger	Antiemulsión
KTC	8	8A00 93036	1	Tubo	Pipe	Tuyau	Rohr	Tubo
WB	8	8A00 A6242	1	Tubo mandata olio	Oil pipe	Tuyauterie d'huile	Oelrohr	Tubo aceite
	9	8000 A9349	1	Regolazione	Adjuster	Registre	Regler	Regulizador
C	10	Z000 56377	1	Rosetta	Washer	Rondelle	Scheibe	Arandela
BKTW	11	8000 H0768	1	Pinza freno	Brake caliper	Etrier frein	Bremssattel	Pinza
C	11	8000 H0771	1	Pinza freno	Brake caliper	Etrier frein	Bremssattel	Pinza
	12	ZA00 62733	2	Vite	Screw	Vis	Schraube	Tornillo
BW	13	8000 A0929	1	Microinterruttore	Microswitch	Microinterrupteur	Microschalter	Microconmutador
	14	U000 57155	2	Vite	Screw	Vis	Schraube	Tornillo
	15	Z000 62729	2	Vite	Screw	Vis	Schraube	Tornillo
	16	8000 21480	4	Rosetta	Washer	Rondelle	Scheibe	Arandela
C	17	8000 A7143	1	Coppia pastiglie	Pads pair	Paire plaquettes	Bremsbelagpaar	Pareja pastillas
BKTW	17	8000 H0770	1	Coppia pastiglie	Pads pair	Paire plaquettes	Bremsbelagpaar	Pareja pastillas
	18	8000 A0932	1	Perni	Pin	Pivot	Bolzen	Perno
	19	8000 A0931	1	Spurgo	Drain	Vidange	Entleerung	Purga
	20	8000 53259	1	Parapolvere	Boots	Para-poudr	Schutzhaube	Para-polvo
	21	8000 A7144	1	Molla-lamierino	Spring-steel clip	Ressort	Feder	Rresorte
	22	8000 79066	1	Cuffie	Boots	Poussiers	Haube	Gorro

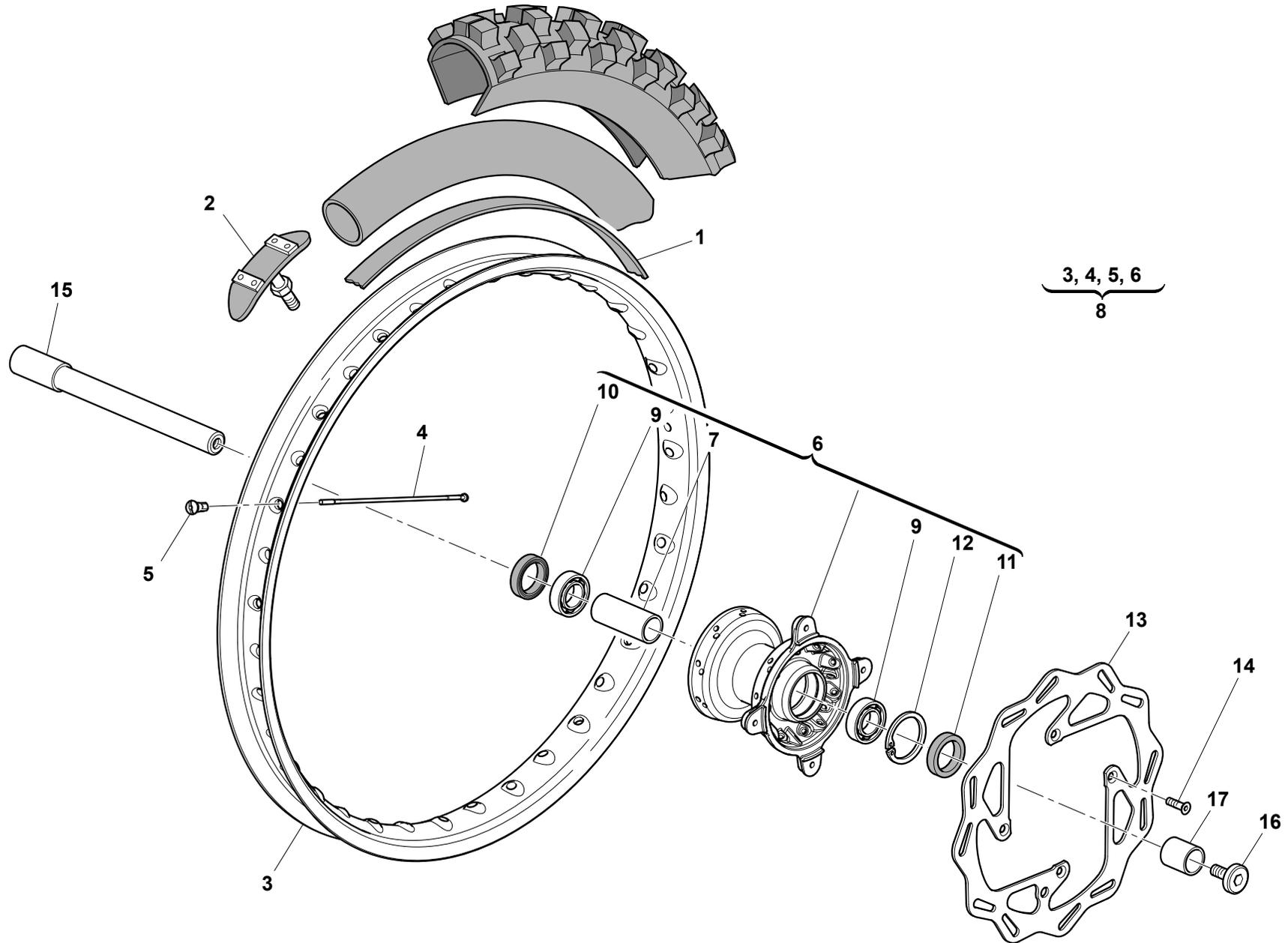

RUOTA ANTERIORE - FRONT WHEEL  
ROUE AV. - VORTERRAD  
RUEDA DELANTERA

Note Notes Notes Marke Notas	Pos. No. Index Pos.	N. Cod. Code No. Nr. Code Code Nr N. Cod.	Q.tà Q.ty Q.te M.ge C.ad	DENOMINAZIONE	NAME	DESIGNATION	BESHREIBUNG	DENOMINACION
	1	8000 13346	1	Fascia copriraggi	Rim strip	Bande	Band	Banda
	2	8000 49036	1	Staffa fermacopertone	Bracket	Etrier	Buegel	Brida
C	3	80A0 H1361	1	Cerchio (1,6"x21")	Rim (1,6"x21")	Jante (1,6"x21")	Felge (1,6"x21")	Llanta (1,6"x21")
KTWB	3	80A0 H2079	1	Cerchio (1,6"x21")	Rim (1,6"x21")	Jante (1,6"x21")	Felge (1,6"x21")	Llanta (1,6"x21")
	4	8000 H1362	36	Raggio	Spoke	Bras	Speiche	Radio
	5	8000 A6208	36	Nipplo ALPINA	Nipple ALPINA	Nipple ALPINA	Nippel ALPINA	Nipple ALPINA
	6	8000 H1363	1	Mozzo completo	Hub assy	Moyeau compl.	Radnabe, Kpl.	Cubo compl.
	7	8000 H6186	1	Distanziale	Spacer	Entretoise	Distanzstück	Separador
C	8	8A00 H1360	1	Ruota anteriore nuda	Front wheel	Roue antérieure	Vorder Rad	Rueda anterior
KTWB	8	8A00 H2272	1	Ruota anteriore nuda	Front wheel	Roue antérieure	Vorder Rad	Rueda anterior
	9	8000 84938	2	Cuscinetto a sfere	Ball bearing (ø25xø42x9 mm)	Roulement à billes (ø25xø42x9 mm)	Kugellager (ø25xø42x9 mm)	Cojinete de bolas (ø25xø42x9 mm)
	10	8000 H6187	1	Anello di tenuta (ø28xø50x5 mm)	Seal ring (ø28xø50x5 mm)	Bague d'étancheite (ø28xø50x5 mm)	Dichtring (ø28xø50x5 mm)	Anillo de retención (ø28xø50x5 mm)
	11	8000 22966	1	Anello di tenuta	Seal ring (ø32xø42x7 mm)	Bague de retenue (ø32xø42x7 mm)	Dichtring (ø32xø42x7 mm)	Anillo de retención (ø32xø42x7 mm)
	12	66N0 21270	1	Anello elastico	Snap ring	Circlip	Sprengring	Anillo elástico
	13	8000 H0192	1	Disco freno (ø260 mm)	Brake disc (ø260 mm)	Disque frein (ø260 mm)	Bremsscheibe (ø260 mm)	Disco freno (ø260 mm)
	14	YA00 55241	4	Vite	Screw	Vis	Schraube	Tornillo
	15	8000 H1547	1	Perno ruota	Pin	Pivot	Bolzen	Perno ruoda
	16	8000 96933	1	Vite	Screw	Vis	Schraube	Tornillo
	17	8A00 96930	1	Distanziale	Spacer	Entretoise	Distanzstück	Separador

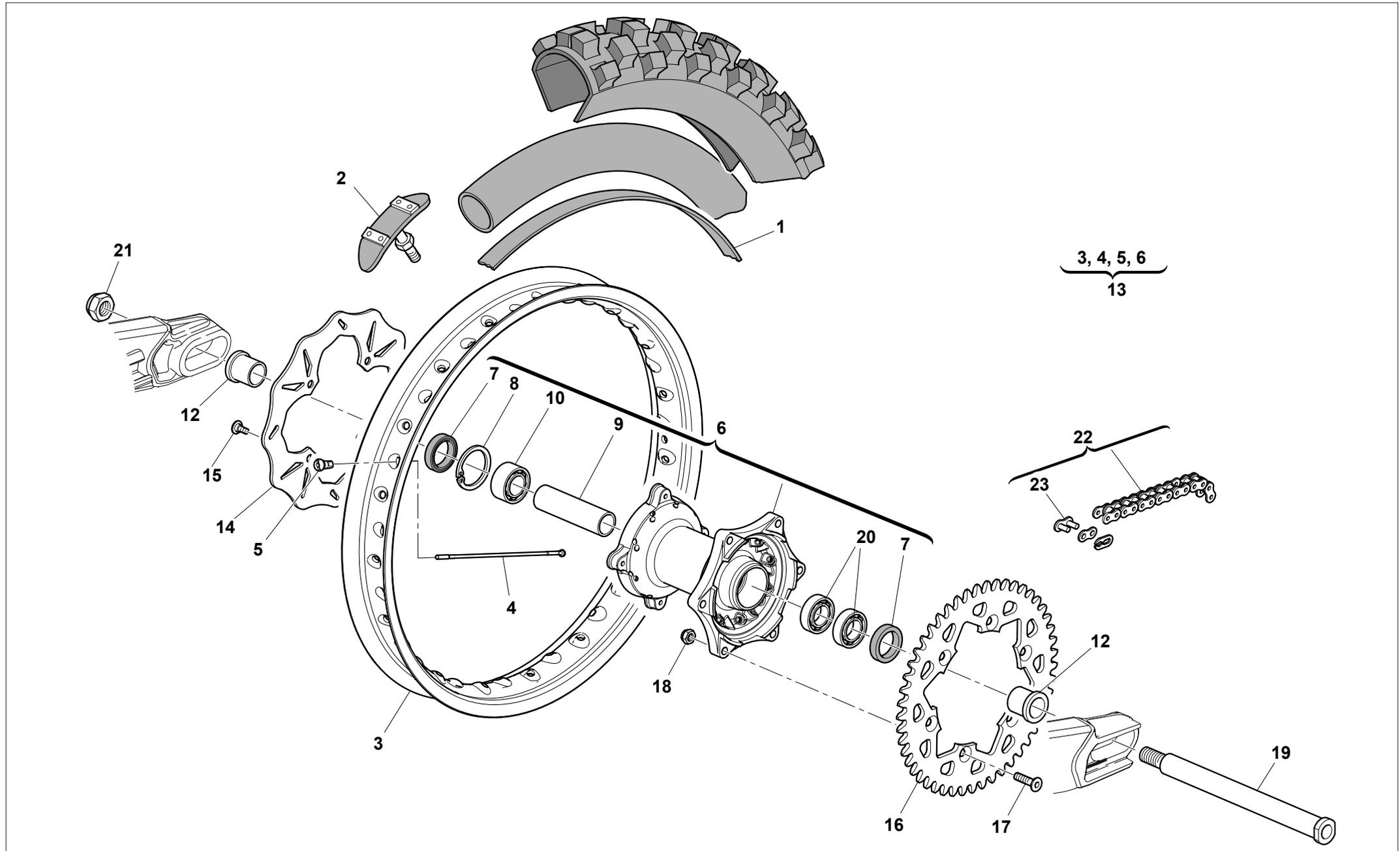

RUOTA POSTERIORE - REAR WHEEL  
ROUE ARRIERE - HINTERRAD  
RUEDA TRASERA

Note Notes Notes Marke Notas	Pos. No. Index Pos.	N. Cod. Code No. Nr. Code Code Nr N. Cod.	Q.tà Q.ty M.ge C.ad	DENOMINAZIONE	NAME	DESIGNATION	BESHREIBUNG	DENOMINACION
KTWB	1	8000 01688	1	Fascia copriraggi	Rim strip	Bande	Band	Banda
C	1	8000 10777	1	Fascia copriraggi	Rim strip	Bande	Band	Banda
C	2	8000 49035	1	Staffa fermacopertone	Bracket	Etrier	Buegel	Brida
KTWB	2	8000 54073	1	Staffa fermacopertone	Bracket	Etrier	Buegel	Brida
KTWB	3	80A0 H1532	1	Cerchio (2,15"x18")	Rim (2,15" x 18")	Jante (2,15" x 18")	Felge (2,15" x 18")	Llanta (2,15" x 18")
C	3	80A0 H2081	1	Cerchio (1,85"x19")	Rim (1,85"x19")	Jante (1,85"x19")	Felge (1,85"x19")	Llanta (1,85"x 9")
C	4	8000 H1366	18	Raggio lato disco	Spoke brake side	Bras côte frein	Speiche Bremsseite	Radio lato disco
C	4	8000 H1367	18	Raggio lato corona	Spoke ring gear side	Bras côte couronne	Speiche Kranzseite	Radio lato corona
KTWB	4	8000 H1533	18	Raggio lato disco	Spoke brake side	Bras côte frein	Speiche Bremsseite	Radio lato disco
KTWB	4	8000 H1534	18	Raggio lato corona	Spoke ring gear side	Bras côte couronne	Speiche Kranzseite	Radio lato corona
	5	8000 A6209	36	Niplo ALPINA	Nipple ALPINA	Nipple ALPINA	Nippel ALPINA	Nipple ALPINA
	6	8000 H1368	1	Mozzo completo	Hub assy	Moyeau compl.	Radnabe, Kpl.	Cubo compl.
	7	8000 89572	2	Anello di tenuta	Seal ring Ø32xØ47x7	Bague de retenuta Ø32xØ47x7	Dichtring Ø32xØ47x7	Anillo de retención Ø32xØ47x7
	8	66N0 21272	1	Anello elastico	Snap ring	Circlip	Sprengring	Anillo elástico
	9	8000 H6189	1	Distanziale	Spacer	Entretoise	Distanzstück	Separador
	10	8B00 26846	1	Cuscinetto	Bearing	Roulement	Kugellager	Cojinete
	12	8000 96938	2	Distanziale	Spacer	Entretoise	Distanzstück	Separador
C	13	8A00 H2273	1	Ruota posteriore completa	Back wheel assy	Roue postérieure complète	Hinter Rad Kpl.	Rueda posterior completa
KTWB	13	8B00 H1530	1	Ruota posteriore completa	Back wheel assy	Roue postérieure complète	Hinter Rad Kpl.	Rueda posterior completa
KTWB	14	8000 H4977	1	Disco freno	Brake disc	Disque frein	Bremsscheibe	Disco freno
C	14	8A00 H4977	1	Disco freno	Brake disc	Disque frein	Bremsscheibe	Disco freno
	15	8000 55878	4	Vite	Screw	Vis	Schraube	Tornillo
CKT	16	8D00 96837	1	Corona (Z=50)	Ring gear (Z=50)	Couronne (Z=50)	Kranz (Z=50)	Corona (Z=50)
DWB	16	8D00 96837	1	Corona (Z=50)	Ring gear (Z=50)	Couronne (Z=50)	Kranz (Z=50)	Corona (Z=50)
WB	16	8D00 A4859	1	Corona (Z=40)	Ring gear (Z=40)	Couronne (Z=40)	Kranz (Z=40)	Corona (Z=40)
	17	8000 H0158	6	Vite	Screw	Vis	Schraube	Tornillo
	18	Y000 43928	6	Dado	Nut	Ecrou	Mutter	Tuerca
	19	8000 H1548	1	Perno	Pin	Pivot	Bolzen	Perno
	20	8A00 26846	2	Cuscinetto	Bearing	Roulement	Kugellager	Cojinete
	21	Y000 93072	1	Dado	Nut	Ecrou	Mutter	Tuerca
DWBTK	22	8000 A6261	1	Catena Regina 5/8"x1/4" (112 maglie)	Chain Regina 5/8"x1/4" (112 link)	Chaîne Regina 5/8"x1/4" (112 maillon)	Kette Regina 5/8"x1/4" (112 schake)	Cadena Regina 5/8"x1/4" (112 malla)
C	22	8A00 56768	1	Catena Regina 5/8"x1/4" (112 maglie)	Chain Regina 5/8"x1/4" (112 link)	Chaîne Regina 5/8"x1/4" (112 maillon)	Kette Regina 5/8"x1/4" (112 schake)	Cadena Regina 5/8"x1/4" (112 malla)
WB	22	8C00 A6261	1	Catena DID 5/8"x1/4" (106 maglie)	Chain DID 5/8"x1/4" (106 link)	Chaîne DID 5/8"x1/4" (106 maillon)	Kette DID 5/8"x1/4" (106 schake)	Cadena DID 5/8"x1/4" (106 malla)

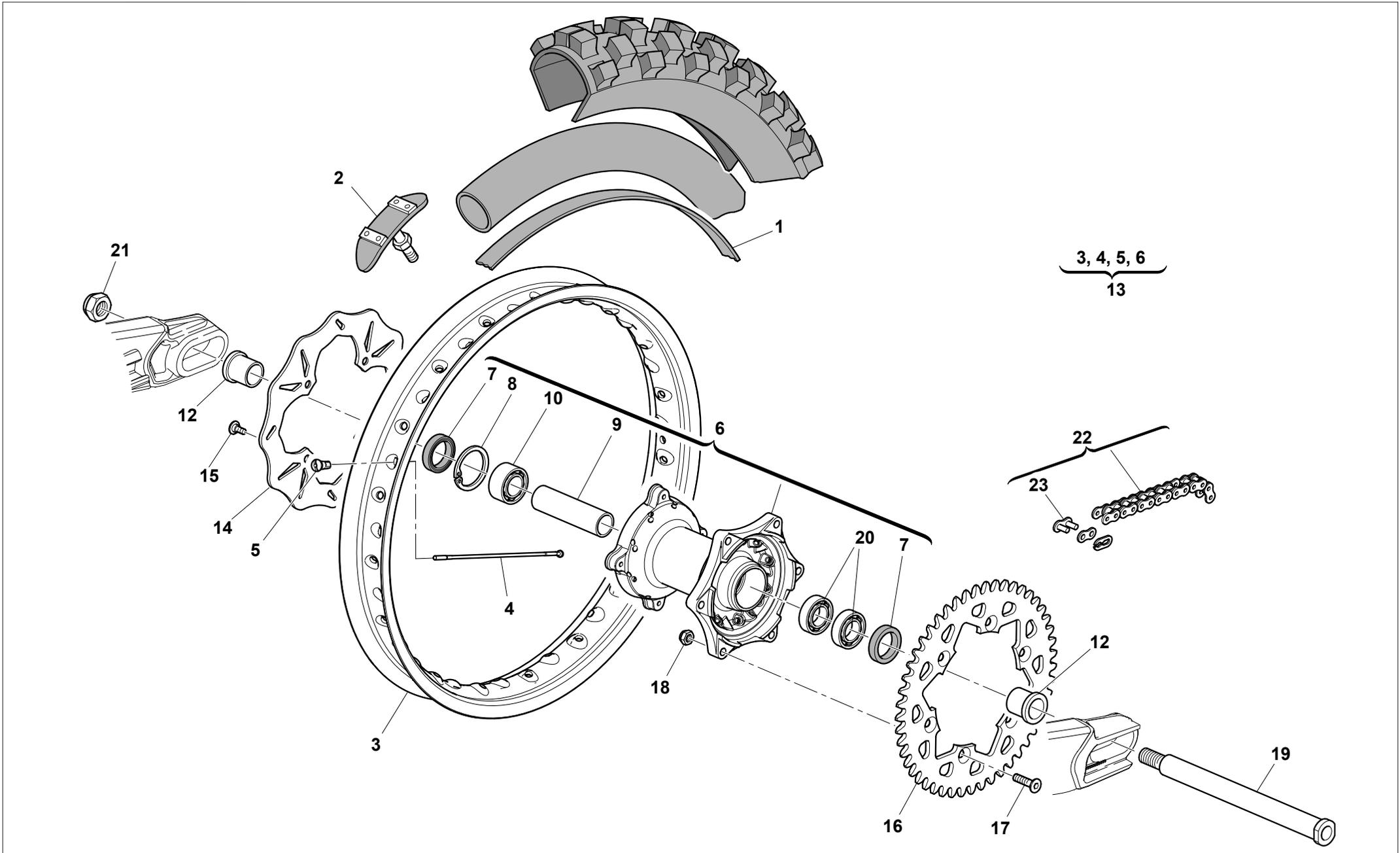





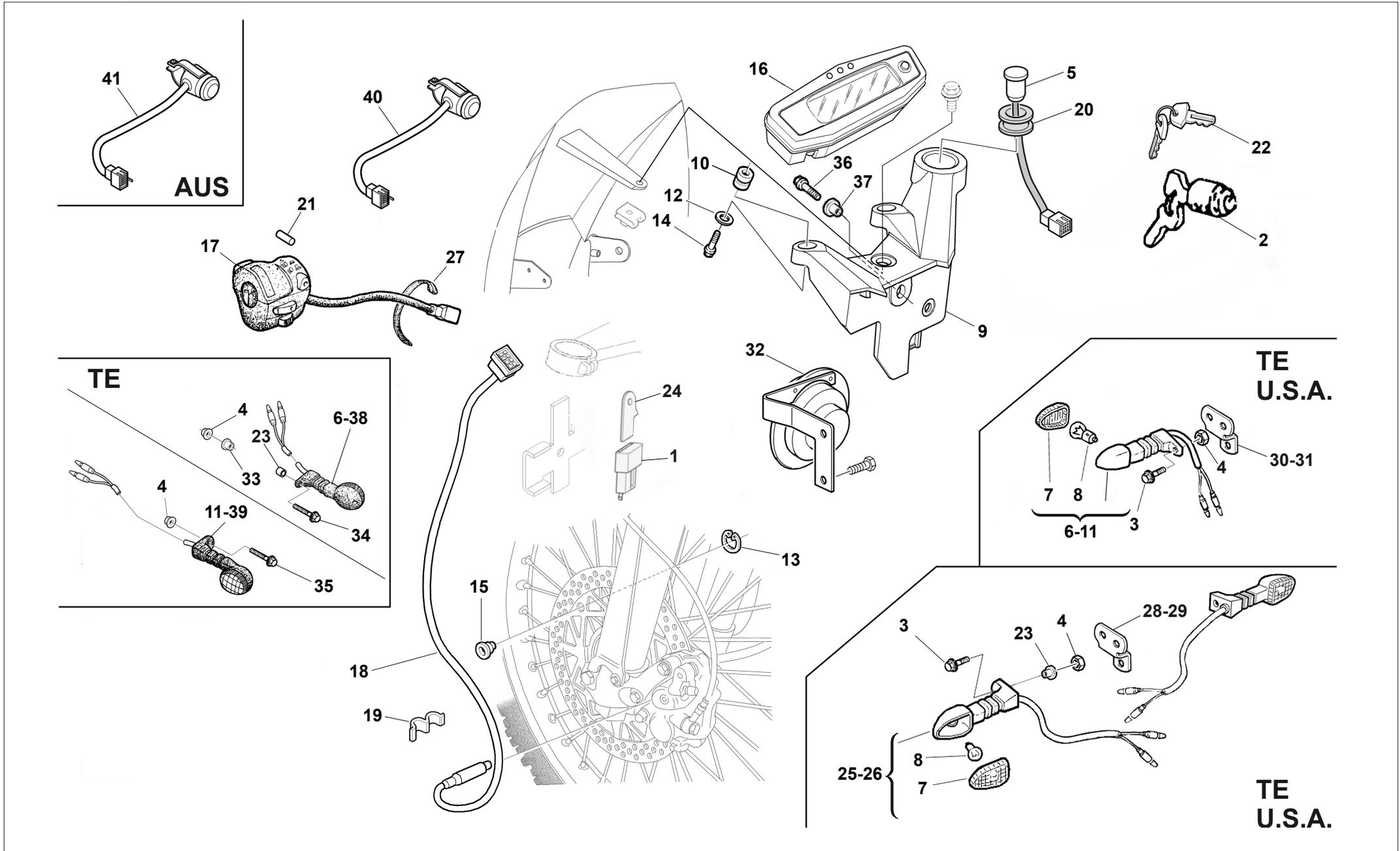

**STRUMENTO DIGITALE, INDICATORI DI DIREZIONE, AVVISATORE ACUSTICO - DIGITAL INSTRUMENT, BLINKERS, HORN - INSTRUMENT DIGITAL, CLIGNOTANTS, SIGNALATEUR ACOUSTIQUE - DIGITAL TACHOMETER, BLINKERS, HUPE - INSTRUMENTO DIGITAL, INTERMITENTES, AVISADOR ACUSTICO**



Note Notes Notes Marke Notas	Pos. No. N. Index Pos.	N. Cod. Code No. Nr. Code Code Nr N. Cod.	Q.tà Q.ty Q.te M.ge C.ad	DENOMINAZIONE	NAME	DESIGNATION	BESHREIBUNG	DENOMINACION
	1	8000 H1082	1	Intermittenza	Flash device	Intermittence	Blinkgeber	Intermitencia
	2	8000 43391	1	Serratura antifurto completa	Anti-left lock assy	Serrure anti-vol compl.	Sicherheitsschloss kpl.	Cerradura compl.
	3	8000 62727	4	Vite	Screw	Vis	Schraube	Tornillo
	4	Z000 44240	4	Dado	Nut	Ecrou	Mutter	Tuerca
	5	8538907	1	Spia	Light	Lumière	Licht	Luz
U	6	8000 78337	1	Indicatore ant. Dx	Front R.H. blinker	Clignotant D. avant	Vordere R. Blinker	Intermitente D. del.
X	6	8000 A0230	1	Indicatore post. Sx	Front L.H. blinker	Clignotant G. avant	Vordere L. Blinker	Intermitente I. tras.
U	7	8000 74507	4	Lente (U.S.A.)	Lens (U.S.A.)	Loupe (U.S.A.)	Linse (U.S.A.)	Lente (U.S.A.)
U	8	8000 36726	4	Lampada (12V-10W)	Lamp (12V-10W)	Lampe (12V-10W)	Lampe (12V-10W)	Lamparilla (12V-10W)
	9	8000 H0315	1	Piastra	Plate	Plaque	Platte	Placa
	10	8000 H0316	2	Gommino	Rubber pad	Pièce caoutchouc	Gummistück	Junta de goma
U	11	8000 78338	1	Indicatore ant. Sx	Front L.H. blinker	Clignotant G. avant	Vordere L. Blinker	Intermitente I. del.
X	11	8000 A0228	1	Indicatore ant. Sx	Front L.H. blinker	Clignotant G. avant	Vordere L. Blinker	Intermitente I. del.
	12	62ND 15548	2	Rosetta	Washer	Rondelle	Scheibe	Arandela
	13	66N0 21200	1	Anello elastico	Snap ring	Circlip	Sprengring	Anillo elástico
	14	8A00 H0534	2	Vite	Screw	Vis	Schraube	Tornillo
	15	8000 99775	1	Magnete	Magnet	Aimant	Magnet	Imán
	16	8AA0 H2161	1	Contachilometri digitale	Digital speedometer	Compteur-km digital	Digital Tachometer	Cuenta-kilómetros digital
	17	8538486	1	Commutatore Sx compl.	L.H. Switch compl.	Commutateur G. compl.	L. Kombischalter kpl.	Conmutador Izq. compl.
G	17	8539769	1	Commutatore Sx compl. (AUS)	L.H. Switch compl. (AUS)	Commutateur G. compl. (AUS)	L. Kombischalter kpl. (AUS)	Conmutador Izq. compl. (AUS)
	18	8538492	1	Sensore velocità	Speed sensor	Palpeur	Sensor	Sensòr
	19	8000 A0664	3	Molletta	Tube clip	Ressort	Feder	Resorte
	20	8000 H0084	1	Gommino	Rubber pad	Pièce caoutchouc	Gummistück	Junta de goma
	21	8000 A1074	1	Piolo in gomma	Peg rubber	Barreau caoutchouc	Pflock gummi	Clavija de goma
	22	8000 35531	1	Chiave grezza	Raw key	Cléf primitive	Schlüssel	Llave
	23	8A00 69634	2	Distanziale	Spacer	Entretoise	Distanzstück	Separador
D	24	8000 H1290	1	Staffa supporto intermittenza	Device support	Support intermittence	Halterung Blinkgeber	Soporte intermitencia
U	25	8000 78340	1	Indicatore post. Sx	Front L.H. blinker	Clignotant G. avant	Vordere L. Blinker	Intermitente I. tras.
U	26	8000 78339	1	Indicatore post. Dx	Front R.H. blinker	Clignotant D. avant	Vordere R. Blinker	Intermitente I. tras.
	27	8000 71578	2	Fascetta	Clamp	Collier	Schelle	Banda
U	28	8A00 A6642	1	Piastrina SX	L.H.Plate	Plaque G.	L. Platte	Placa I.
U	29	8000 A6642	1	Piastrina DX	R.H.Plate	Plaque D.	R. Platte	Placa D.
U	30	8000 H3189	1	Piastrina SX	L.H.Plate	Plaque G.	L. Platte	Placa I.

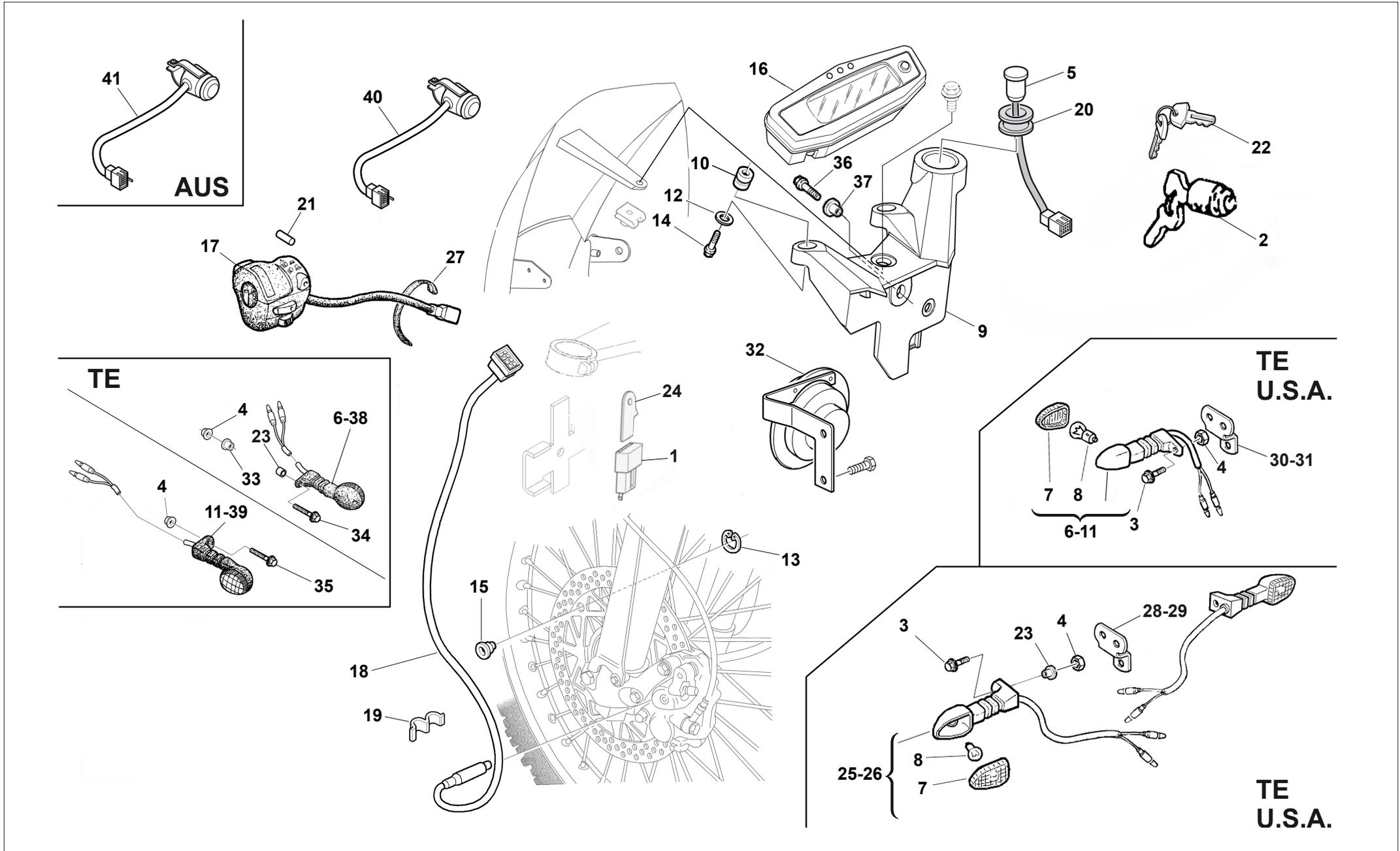



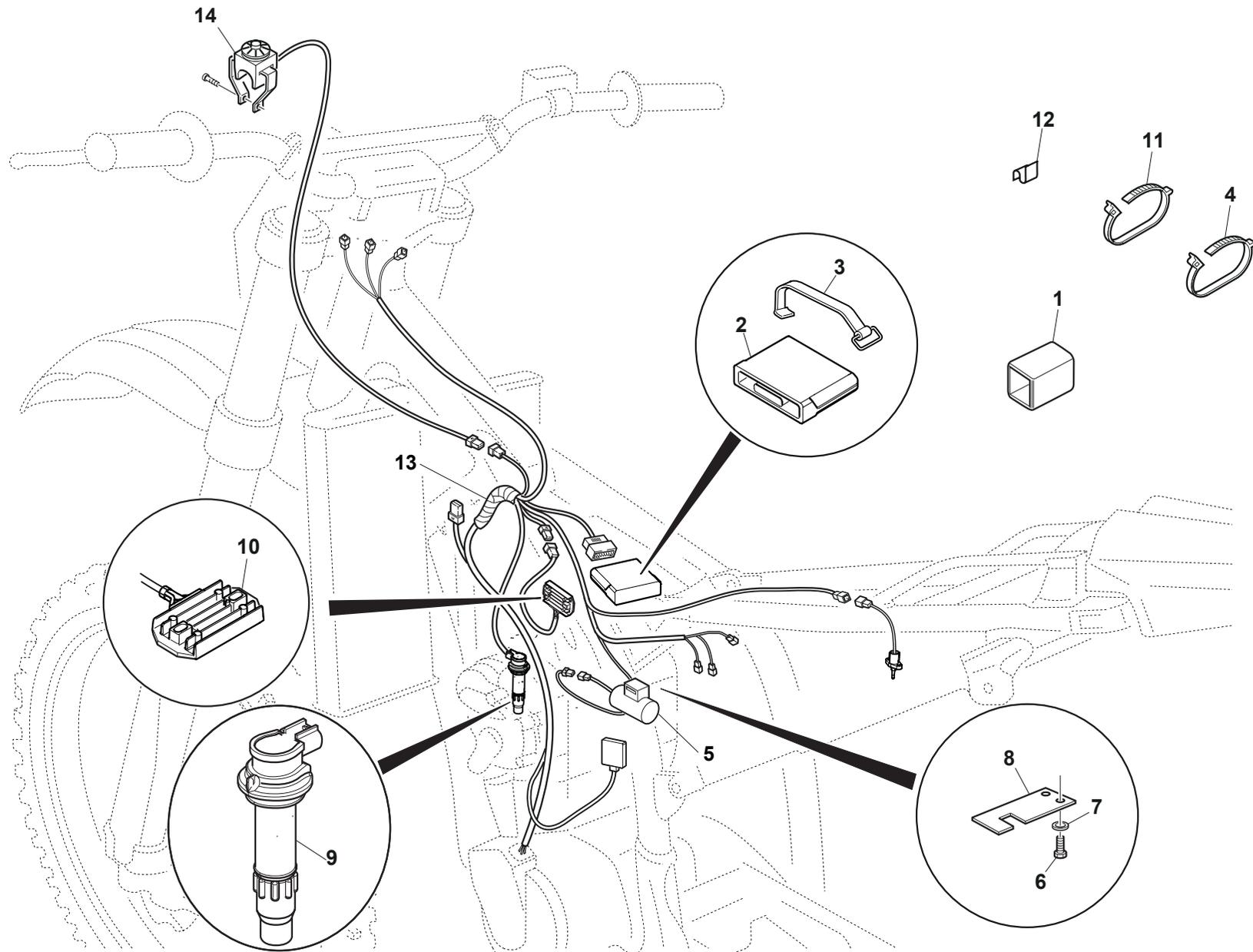



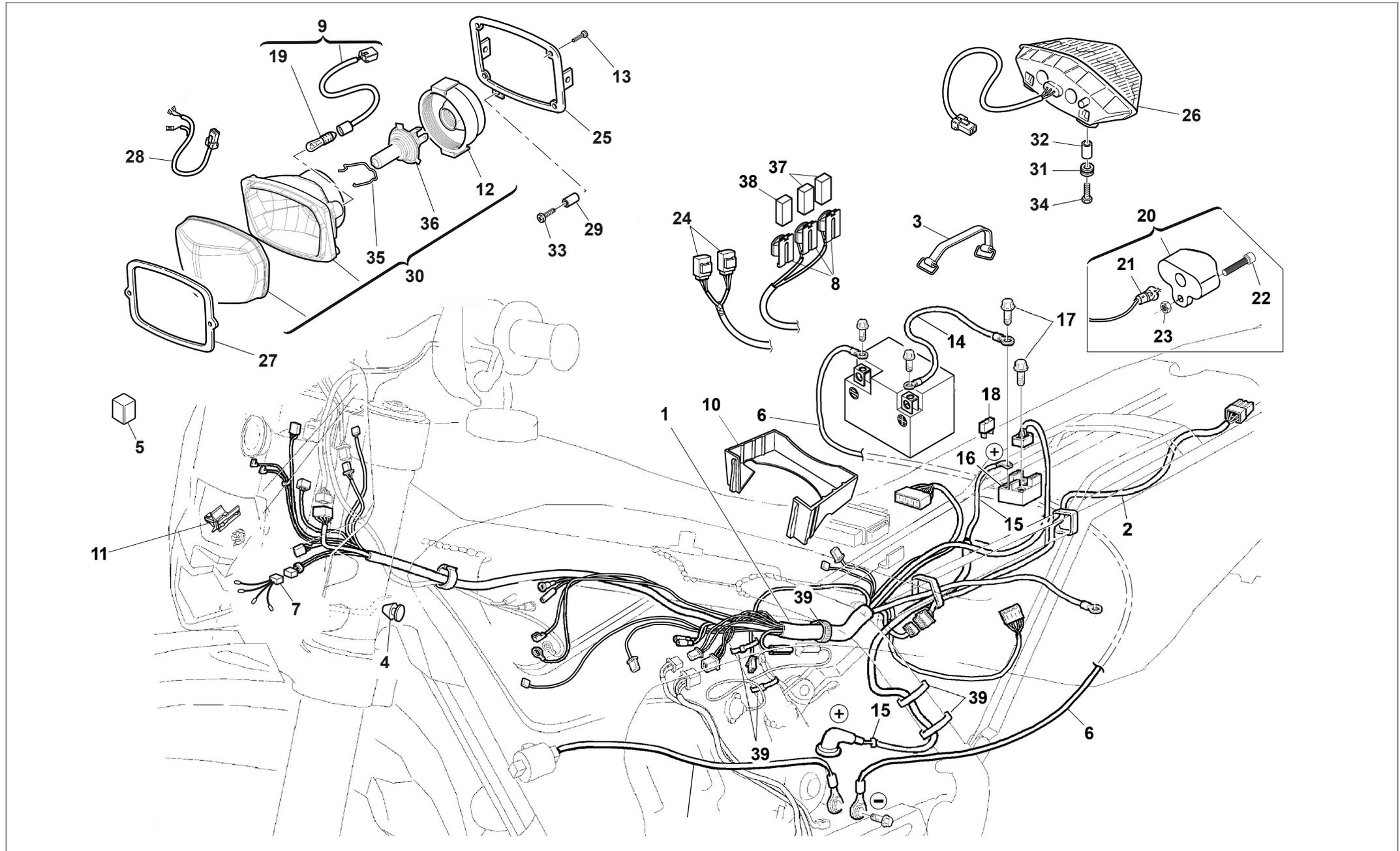



**GRUPPO CAVI, PARTI ELETTRICHE - MAIN WIRING HARNESS, ELECTRICAL PARTS -  
CABLES PRINCIPAL, PARTIES ELECTRIQUES - KABEL, ELEKTRISCHE KOMPONENTE -  
GRUPO PRINCIPAL CABLES, PARTES ELECTRICAS**



Note Notes Notes Marke Notas	Pos. No. N. Index Pos.	N. Cod. Code No. Nr. Code Code Nr N. Cod.	Q.tà Q.ty Q.te M.ge C.ad	DENOMINAZIONE	NAME	DESIGNATION	BESHREIBUNG	DENOMINACION
	1	8538481	1	Gruppo principale cavi	Cable assy	Câbles compl.	Kabel Kpl.	Grupo principal cables
	2	8538488	1	Cavo fanale posteriore	Cable	Cable	Kabel	Cable
	3	8000 77612	1	Elastico	Elastic band	Elastique	Elastisch	Elástico
	4	8000 B0841	1	Tappo	Plug	Bouchon	Verschluss	Tapón
	5	8000 A6790	1	Tappo connettore diagnosi	Check instrument plug	Bouchon conn. de diagnostic	Verschluss Diagnoseanschluss	Tapón conn. diagnosis
	6	8000 H1828	1	Cavo batteria-massa	Battery-Ground cable	Cable batterie-masse	Kabel Batterie-Masse	Cable Batería-Masa
	7	8538487	1	Cablaggio indicatori direzione	Direction blinker cable	Cable direction clignotant	Richtung Blinker Kabel	Cable intermitente dirección
	8	8000 H0641	2	Supporto	Support	Support	Halterung	Soporte
	9	8000 95886	1	Porta lampada completo	Light holder assy	Douille compl.	Glühbirnenfassung kpl.	Porta lámpara compl.
	10	8000 H0159	1	Cassetta porta batteria	Battery case	Caisson batterie	Batteriekasten	Caja de batería
	11	8000 H0644	2	Clip fissaggio connettori	Connectors fastening clip	Clip de fixation connecteurs	Befestigungsclip Verbinder	Fijación conectores
	12	8000 H1775	1	Cuffia fanale	Boots	Poussiers	Haube	Gorro
	13	Z000 A6635	4	Vite	Screw	Vis	Schraube	Tornillo
	14	8538484	1	Cavo batteria-teleruttore	Battery-Remote switch cable	Cable batterie-telerupteur	Kabel Batterie-Fernshalter	Cable Batería-Telerruptor
	15	8538485	1	Cavo motorino avviamento	Starting motor cable	Cable moteur demarrage	Anlasser motor kabel	Cable motor de arranque
	16	8000 H3644	1	Teleruttore avviamento	Remote switch	Telerupteur	Fernshalter	Telerruptor
	17	ZS00 67545	2	Vite	Screw	Vis	Schraube	Tornillo
	18	8000 47473	2	Fusibile (15A)	Fuse (15A)	Fusible (15A)	Sicherung (15A)	Fusible (15A)
	19	8000 36230	1	Lampada (12V-5W)	Lamp (12V-5W)	Lampe (12V-5W)	Lampe (12V-5W)	Lamparilla (12V-5W)
	20	8000 A0212	1	Luce targa	Plate illumination	Éclairage de plaque	Kennzeichen-Beleuchtung	Iluminación matricula
	21	8000 36230	1	Lampada (12V-5W)	Lamp (12V-5W)	Lampe (12V-5W)	Lampe (12V-5W)	Lamparilla (12V-5W)
	22	60ND 07330	1	Vite	Screw	Vis	Schraube	Tornillo
	23	61ND 15192	1	Dado	Nut	Ecrou	Mutter	Tuerca
	24	8000 A6749	2	Relè	Relay	Relais	Relais	Relais
	25	8000 A6484	1	Fissaggio fanale	Headlamp holder	Support pour phare-avant	Vorderleuchtehalterung	Soporte faro delantero
	26	8538462	1	Fanale posteriore completo	Tail light	Feux arrière	Hinterleuchte	Faro trasero
	27	8000 A1053	1	Guarnizione	Gasket	Garniture	Dichtung	Junta
	28	8000 A6094	1	Cavo fanale anteriore	Cable	Cable	Kabel	Cable
	29	8A00 A1051	1	Distanziale	Spacer	Entretoise	Distanzstück	Separador
	30	8000 H1736	1	Fanale anteriore completo	Front light	Feux antérieur	Scheinwerfer	Faro delantero
	31	8000 95128	2	Antivibrante	Silent-block	Antivibration	Schwingungsdämpfer	Anti-vibrador
	32	8000 H1735	2	Distanziale	Spacer	Entretoise	Distanzstück	Separador
	33	60ND 02487	1	Vite	Screw	Vis	Schraube	Tornillo

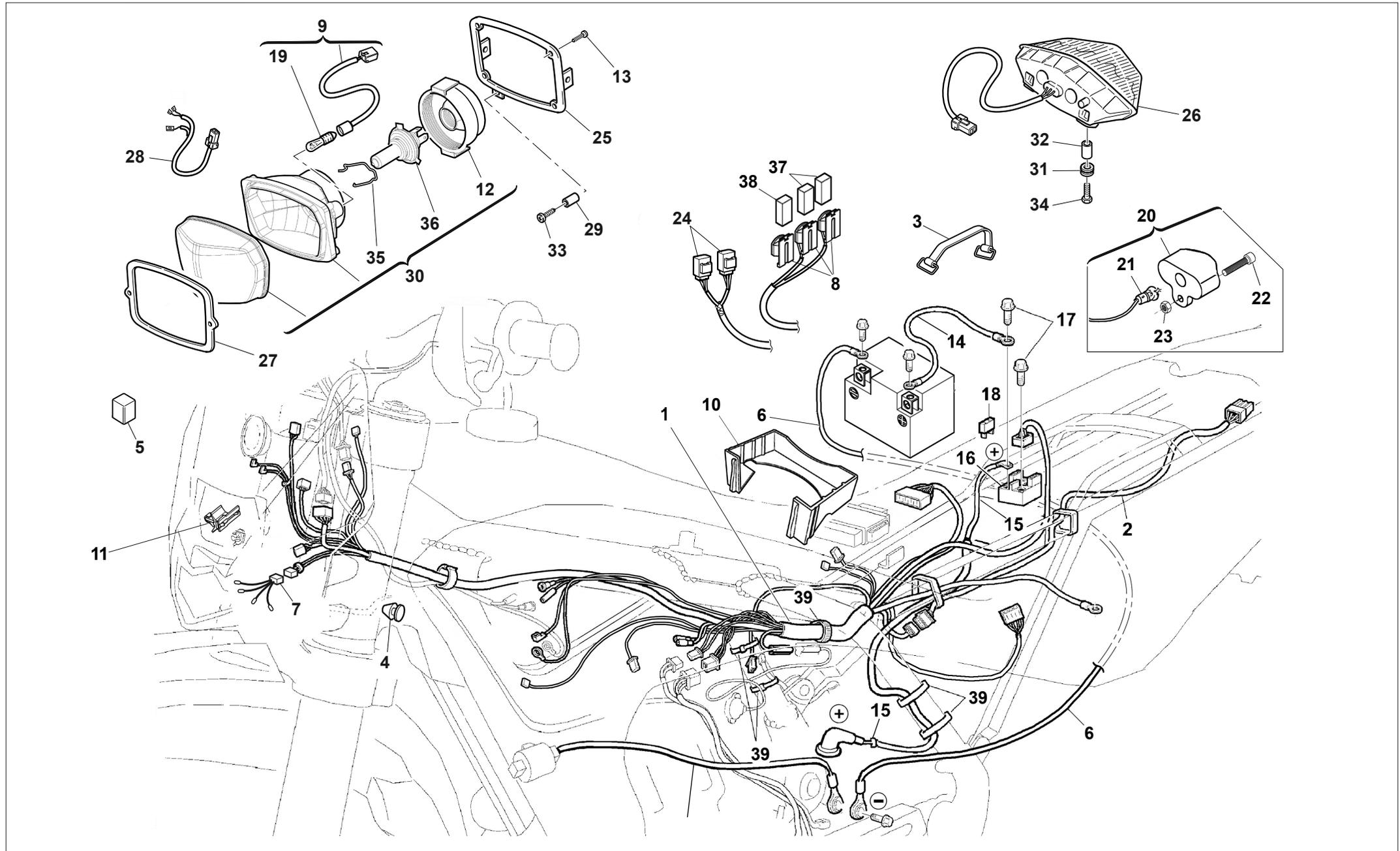







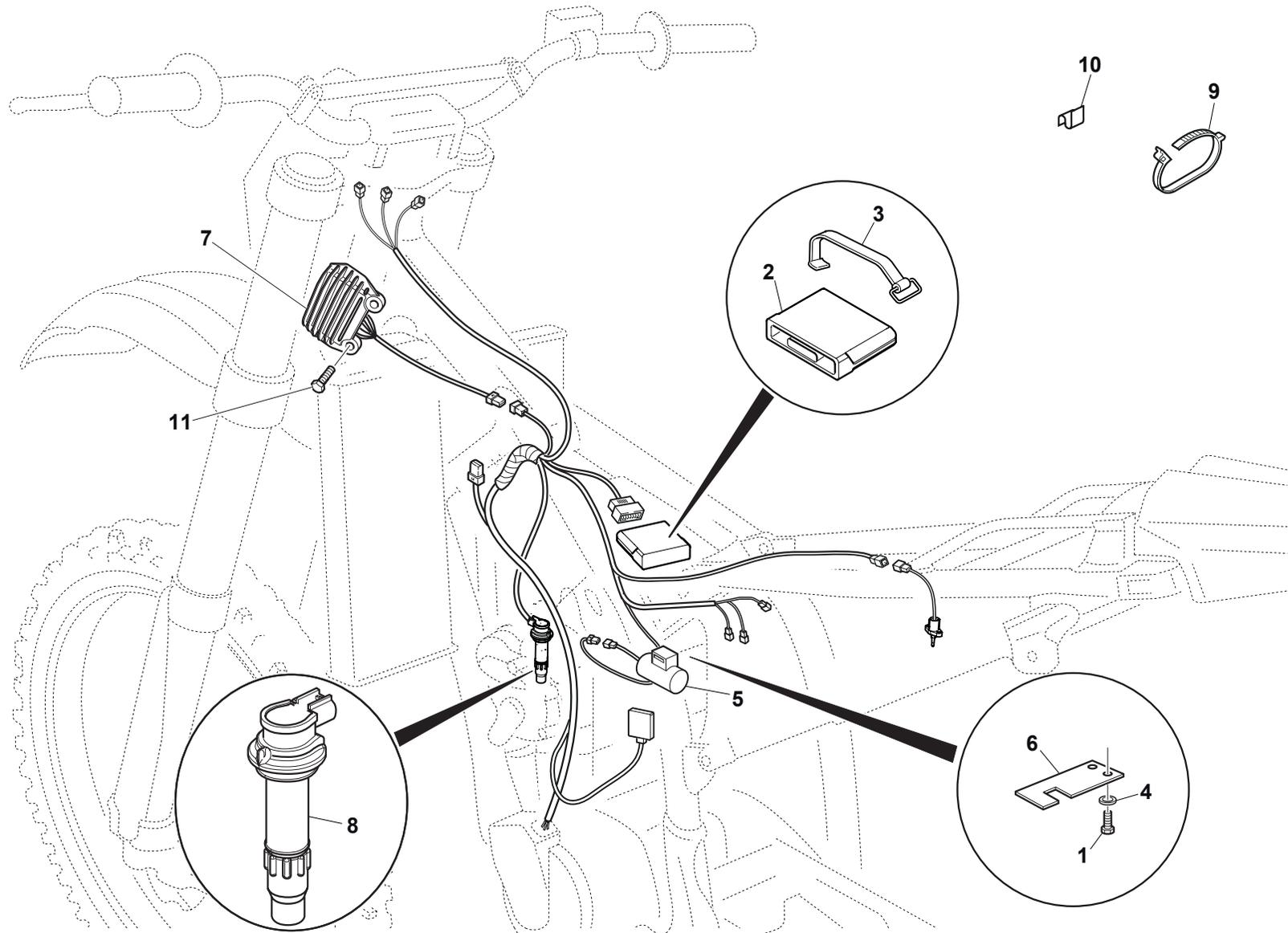

TE-TXC 250/2013  
TE-TXC 310/2013

TAVOLA - DRAWING  
TABLE - BILD - TABLA

34B

PARTE ELETTRICA, IMPIANTO ELETTRICO - IGNITION SYSTEM, ELECTRIC SYSTEM  
PARTIES ELECTRIQUE, INSTALLATION ELECTRIQUE- ELEKTRISCHE TEILE, ELEKTRISCHE ANLAGE  
PARTE ELECTRICA, INSTALACION ELECTRICA



Note Notes Notes Marke Notas	Pos. No. N. Index Pos.	N. Cod. Code No. Nr. Code Code Nr N. Cod.	Q.tà Q.ty Q.te M.ge C.ad	DENOMINAZIONE	NAME	DESIGNATION	BESHREIBUNG	DENOMINACION
	1	60ND 07335	2	Vite	Screw	Vis	Schraube	Tornillo
W	2	8538826	1	Centralina (Europa) E3	E.C.U. (Europa) E3	Dispositif électronique (Europa) E3	Zündelektronik (Europa) E3	Centralita (Europa) E3
W	2	8538827	1	Centralina (AUS) E3	E.C.U. (AUS) E3	Dispositif électronique (AUS) E3	Zündelektronik (AUS) E3	Centralita (AUS) E3
B	2	8538829	1	Centralina (Europa) E3	E.C.U. (Europa) E3	Dispositif électronique (Europa) E3	Zündelektronik (Europa) E3	Centralita (Europa) E3
B	2	8538830	1	Centralina (USA/CAL/CAN) E3	E.C.U. (USA/CAL/CAN) E3	Dispositif électronique (USA/CAL/CAN) E3	Zündelektronik (USA/CAL/CAN) E3	Centralita (USA/CAL/CAN) E3
B	2	8538831	1	Centralina (AUS) E3	E.C.U. (AUS) E3	Dispositif électronique (AUS) E3	Zündelektronik (AUS) E3	Centralita (AUS) E3
T	2	8538832	1	Centralina	E.C.U.	Dispositif électronique	Zündelektronik	Centralita
K	2	8538833	1	Centralina	E.C.U.	Dispositif électronique	Zündelektronik	Centralita
	3	8000 H3651	1	Cinghia	Clamp	Collier	Schelle	Banda
	4	62ND 15504	2	Rosetta	Washer	Rondelle	Scheibe	Arandela
	5	8000 H3369	1	Condensatore	Condenser	Condensateur	Kondensator	Condensador
	6	8000 H6640	1	Piastrina	Plate	Plaque	Platte	Placa
	7	8538482	1	Regolatore di tensione compl.	Voltage rectifier assy.	Régulateur de tension compl.	Spannungsregler Kpl	Regulador de tensión compl.
	8	8000 H6570	1	Bobina	Coil	Bobine	Zündspule	Bobina
	9	8000 56444	23	Fascetta	Clamp	Collier	Schelle	Banda
	10	8000 72494	1	Molletta	Tube clip	Ressort	Feder	Resorte
	11	Z000 62727	2	Vite	Screw	Vis	Schraube	Tornillo

