

**CATALOGO PARTI DI RICAMBIO – PARTS CATALOG  
CATALOGUE PIECES DE RECHANGE – ERSATZTEILKATALOG  
CATALOGO PIEZAS DE REPUESTO**

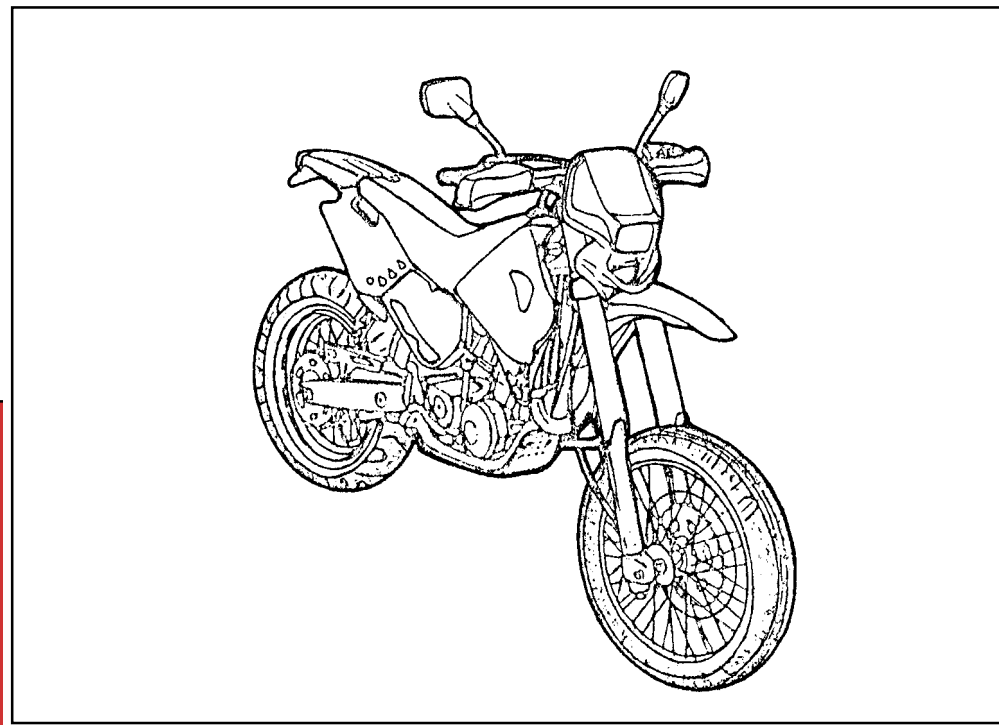

**Part. N° 8A00 92967**

***SM 610 R / 2000***

## INFORMAZIONI GENERALI

Il presente catalogo serve per richiedere con esattezza le parti di ricambio

Nelle ordinazioni indicare:

- 1) il numero di codice dei particolari seguito dalla descrizione;
- 2) il colore per i pezzi verniciati o comunque colorati;
- 3) il numero di matricola del motociclo, stampigliato sul canotto di sterzo.

Le indicazioni destra e sinistra si riferiscono ai lati del veicolo rispetto al senso di marcia.

## GENERAL INFORMATION

The present spare parts list enables one to order exactly the right spare parts.

When ordering specify:

- 1) the part's code number followed by its description;
  - 2) indicate colour for painted or coloured parts;
  - 3) the motorcycle's serial number, stamped on the steering head.
- References to right and left apply to the vehicle in terms of its direction of movement.

## INFORMATIONS GENERALES

Ca catalogue permet de commander correctement les pièces de rechange.

Les commandes doivent être passées en indiquant:

- 1) le numéro de code des pièces détachées suivi de leur description;
- 2) le couleur des pièces peintes ou colorés;
- 3) le matricule de la moto, estampillé sur la tige du guidon.

Droite et gauche sont les côtés du véhicule par rapport au sens de la marche.

## ALLGEMEINE HINWEISE

Dieser Ersatzteilkatalog dient zur genauen Angabe der Teile bei Ersatzteilbestellungen.

Bei Ersatzbestellung ist folgendes anzugeben:

- 1) Die Bestellnummer der Ersatzteile mit der entsprechenden Beschreibung;
  - 2) Farbe für lackierte und farbige Teile angeben;
  - 3) Die Sseriennummer des Motorrads, die am Lenkrohr eingepreßt ist.
- Die Angaben rechts und links beziehen sich auf das Fahrzeug in Fahrrichtung.

## INFORMACIONES GENERALES

El presente catálogo sirve para pedir con exactitud las partes de recambio.

En los pedidos se debe indicar:

- 1) el número de código de la parte y a continuación la descripción;
- 2) el color para las piezas barnizadas o coloreadas;
- 3) el número de matrícula de la motocicleta, estampado en el tubo de dirección.

Las indicaciones derecha e izquierda se refieren a los lados del vehículo respecto del sentido de marcha.

## NOTE - LIST - NOTES - NOTE - NOTAS:

- A** : In alternativa - In alternative - En alternative  
Wahlweise - En alternativa
- D** : In dotazione - To issue - En necessaire  
Ausrüstungsteile - En dotación
- E** : Ad esaurimento - To fell out - A' finir - Erschöpfung  
A agotamiento
- F** : Fornire assieme - Supply unitedly - Fournir ensemble  
Wird zusammen geliefert - Equipar juntos
- N** : Non fornito - Not supplied - Ne pas fournit  
Keine Gelieferende - No equiparado
- R** : A richiesta - Upon request - Sur demande  
Auf anfrage - Bajo pedido
- S** : Di serie - Supplied - De série - Standard - De serie
- Z** : n° denti, number of teeth, numéro dents, Zähne nummer  
número dientes

Il n° di matricola iniziale del modello **SM 610 R/2000** è **ZCGH601ABYV000010**

The initial serial number for the **SM 610 R/2000** model is **ZCGH601ABYV000010**

Le matricule initial du modèle **SM 610 R/2000** est **ZCGH601ABYV000010**

Die Seriennummer des Modells **SM 610 R/2000** beginnt mit **ZCGH601ABYV000010**

El n° de matricula inicial de la motocicleta **SM 610 R/2000** es **ZCGH601ABYV000010**

- A** : Austria, Austria, Autriche, Österreich, Austria
- AUS** : Australia, Australia, Australie, Australien, Australia
- B** : Belgio, Belgium, Belgique, Belgien, Bélgica
- BR** : Brasile, Brazil, Brasile, Brasilien, Brasil
- CDN** : Canada, Canada, Canada, Kanada, Canadá
- CH** : Svizzera, Switzerland, Suisse, Schweizer, Suiza
- D** : Germania, Germany, Allemagne, Deutschland, Alemania
- E** : Spagna, Spain, Espagne, Spanien, España
- F** : Francia, France, France, Frankreich, Francia
- FIN** : Finlandia, Finald, Finlande, Finnland, Finlandia
- GB** : Gran Bretagna, Great Britain, Grand Bretagne  
Groos Britan, Gran Bretaña
- I** : Italia, Italy, Italie, Italien, Italia
- TA** : Tahiti, Tahiti, Tahiti, Tahiti, Tahiti
- USA** : Stati Uniti d'America, United States of America  
Etats Units d'Amerique,  
Vereinigte Staaten von Amerika, Estados Unidos

Dati indicativi soggetti a modifiche senza impegno di preavviso.

All data are subject to modification without prior notice.

Données indicatif sujet au modifications sans obligation de préavis.

Anderungen Vorbehalten.

Datos indicativos sujetos a modificaciones sin compromiso de preaviso.



Tavola Drawing Table Bild Tabla	Denominazione	Description	Designation	Bezeichnung	Denominacion	Pag
1	ATTREZZI DI ASSISTENZA, .....	SERVICE TOOLS, OWNER'S .....	OUTILS D'ASSISTANCE, EMPLOI .....	HILFAUSRUSTUNG, BETRIEBSANLEITUNG, ....	HERRAMIENTAS DE ASISTENCIA,	
	MANUALI D'ISTRUZIONI E DI SERVIZIO AND SERVICE MANUALS .....	D'ENTRETIEN ET DE SERVICE .....	WERKSTATTHANDBUCH .....	MANUALES DE ISTRUCCIONES Y DE .....	SERVICIO .....	11
2	TESTA, CILINDRO .....	CYLINDER HEAD, CYLINDER .....	CULASSE, CYLINDRE .....	ZYLINDERKOPF, ZYLINDER .....	CULATA, CILINDRO .....	13
3	DISTRIBUZIONE .....	VALVE TIMING .....	DISTRIBUTION .....	VENTILSTEUERUNG .....	DISTRIBUCION .....	19
4	PISTONE, MANOVELLISMO .....	PISTON, CRANKSHAFT .....	PISTON, VILEBREQUIN .....	KOLBEN, KURBELWELLE .....	PISTON, PALANCAS .....	23
5	RAFFREDDAMENTO .....	COOLING SYSTEM .....	REFROIDISSEMENT .....	WASSERKÜHLUNG .....	ENFRIAMIENTO .....	25
6	SEMICARTER DESTRO .....	R.H. HALF CRANKCASE .....	CARTER D. ....	GEHAUSEDECKEL R. ....	BANCADA DER. ....	29
7	SEMICARTER SINISTRO, AVVIAMENTO ZQ., ARRANQUE .....	L.H. HALF CRANKCASE, STARTING .....	CARTER G., DEMARRAGE .....	GEHAUSEDECKEL L., ANLASSERBANCADA		33
8	CAMBIO, COMANDO CAMBIO, .....	TRANSMISSION, SHIFTER, CLUTCH ....	BOITE DE VITESSE, COMMANDE DE ...	WECHSELGETRIEBE, .....	CAMBIO, MANDO CAMBIO , .....	
	FRIZIONE .....	VITESSE, EMBRAYAGE .....	GANGSCHALTUNG,KUPPLUNG .....	EMBRAGUE .....		39
9	ACCENSIONE .....	IGNITION .....	ALLUMAGE .....	ZÜNDUNG .....	ENCENDIDO .....	43
10	CARBURATORE .....	CARBURETOR .....	CARBURATEUR .....	VERGASER .....	CARBURADOR .....	45
11	FILTRO ARIA .....	AIR FILTER .....	FILTRE AIRE .....	AIRFILTER .....	FILTRO DE AIRE .....	51
12	TELAIO, PEDANE .....	FRAME, FOOT RESTS .....	CADRE, REPOSE PIEDS .....	RAHMEN, FUSSBRETT .....	BASTIDOR, REPOSAPIES .....	53
13	SOSPENSIONE ANTERIORE .....	FRONT FORK ASSEMBLY .....	SUSPENSION AVANT .....	VORDERTELESKOPGABEL .....	SUSPENSION DELANTERA .....	57
14	FORCELLONE .....	SWING ARM .....	FOURCHE .....	HINTERGABEL .....	HORQUILLA TRASERA .....	61
15	AMMORTIZZATORE POSTERIORE ....	REAR SHOCK ABSORBER .....	AMMORTISSEUR ARRIÈRE .....	HINTERSTOSSDAMPFER .....	AMORTIGUADOR TRASERO .....	65
16	LEVERAGGI SOSPENSIONE POST. ....	REAR SUSPENSION LINKAGE .....	LEVIER SUSPENSION ARRIERE .....	HEBELWERK HINTERHAUFHANGUNG	PALANCA SUSPENSION TRASERA .....	69
17	MANUBRIO E COMANDI .....	HANDLEBAR AND CONTROLS .....	GUIDON ET COMMANDES .....	LENKER UND STEUERORGANE .....	MANILLAR Y MANDOS .....	71
18	FRENO IDRAULICO POSTERIORE .....	REAR HYDRAULIC BRAKE .....	FREIN HYDRAULIQUE ARRIERE .....	HINTERBREMSE .....	FRENO HIDRAULICO TRASERO .....	75
19	PANNELLI, PARAFANGHI, SELLA .....	PANELS, FENDERS, SEAT .....	PANNEAU, GARDE-BOUES , SIEGE .....	STREIFEN, KOTFLUGEL, SATTEL .....	PANELES, GUARDABARROS, SILLIN .....	77
20	SERBATOIO CARBURANTE .....	GAS TANK .....	RESERVOIR CARBURANT .....	KRAFTSTOFFBEHALTER .....	DEPOSITO GASOLINA .....	79
21	SCARICO .....	EXHAUST SYSTEM .....	TUYAU D'ÉCHAPPEMENT .....	AUSPUFFROHR .....	TUBO DE ESCAPE .....	81
22	FRENO IDRAULICO ANTERIORE .....	FRONT HYDRAULIC BRAKE .....	FREIN HYDRAULIQUE AVANT .....	VORTERBREMSE .....	FRENO HIDRAULICO DELANTERO .....	83





Tavola - Drawing - Table - Bild - Tabla

1

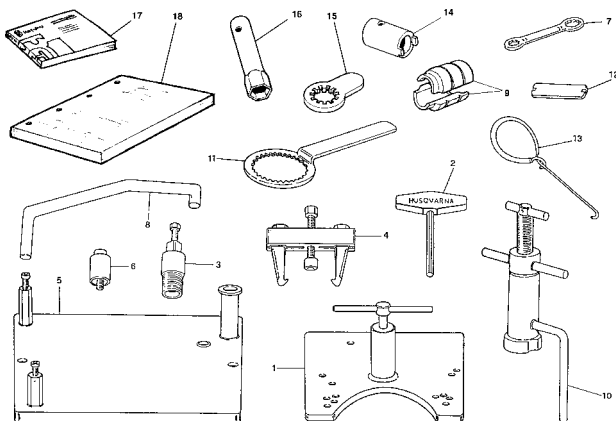

Pagina - Page - Page - Seite - Paja

11

Tavola - Drawing - Table - Bild - Tabla

2

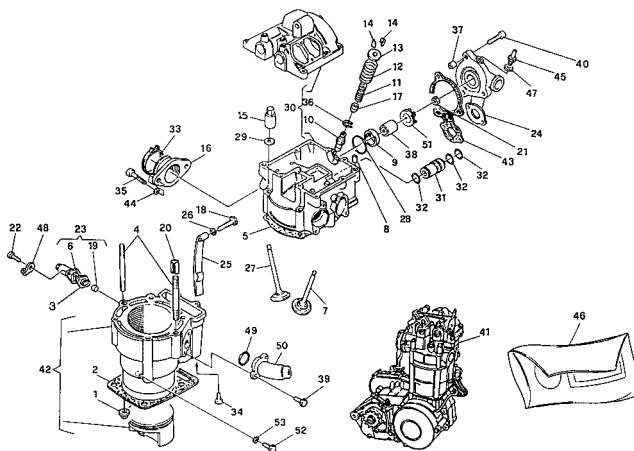

Pagina - Page - Page - Seite - Paja

13

Tavola - Drawing - Table - Bild - Tabla

3

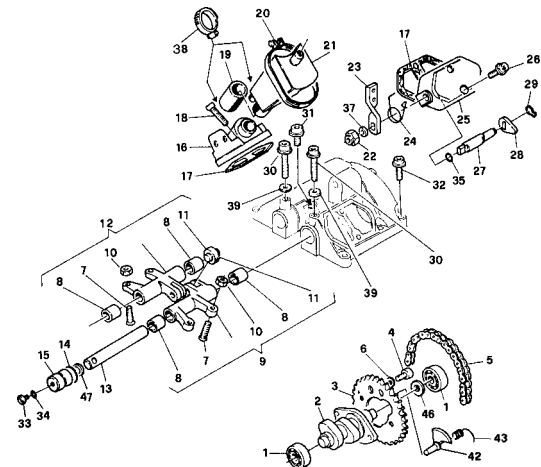

Pagina - Page - Page - Seite - Paja

19

Tavola - Drawing - Table - Bild - Tabla

4

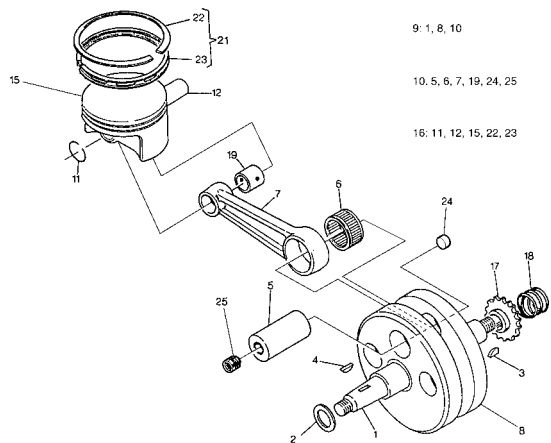

Pagina - Page - Page - Seite - Paja

23

Tavola - Drawing - Table - Bild - Tabla

5

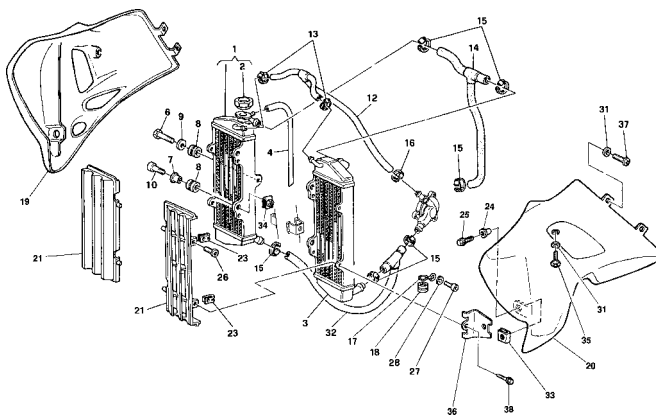

Pagina - Page - Page - Seite - Paja

25

Tavola - Drawing - Table - Bild - Tabla

6

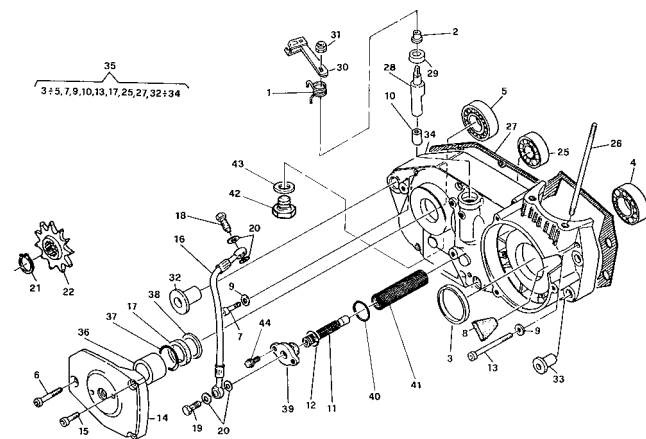

Pagina - Page - Page - Seite - Paja

29



Tavola - Drawing - Table - Bild - Tabla

7

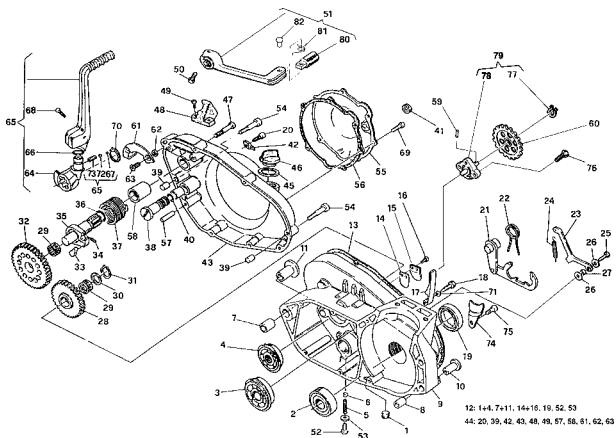

Pagina - Page - Page - Seite - Paja

33

Tavola - Drawing - Table - Bild - Tabla

8

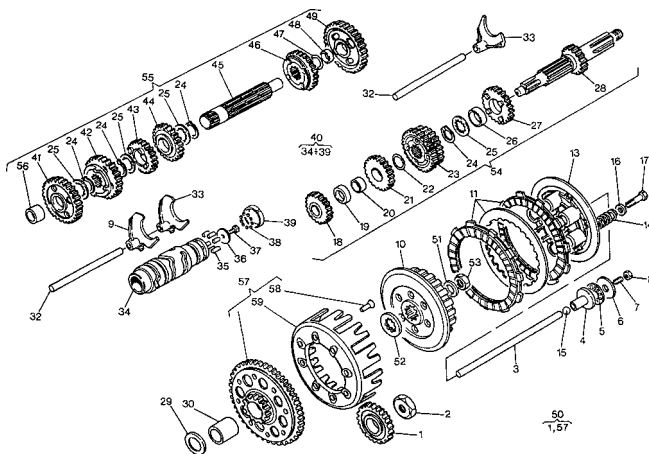

Pagina - Page - Page - Seite - Paja

39

Tavola - Drawing - Table - Bild - Tabla

9

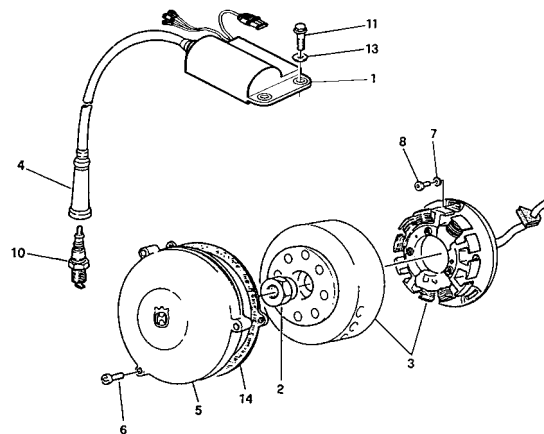

Pagina - Page - Page - Seite - Paja

43

Tavola - Drawing - Table - Bild - Tabla

10

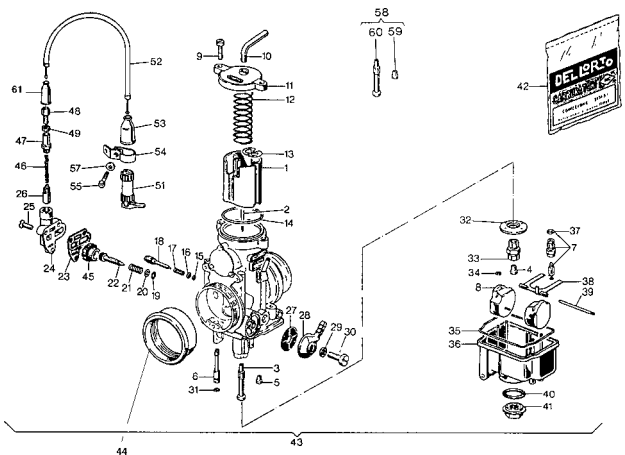

Pagina - Page - Page - Seite - Paja

45

Tavola - Drawing - Table - Bild - Tabla

11

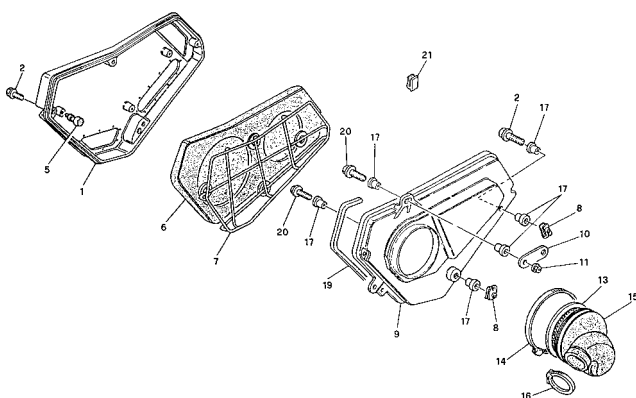

Pagina - Page - Page - Seite - Paja

51

Tavola - Drawing - Table - Bild - Tabla

12

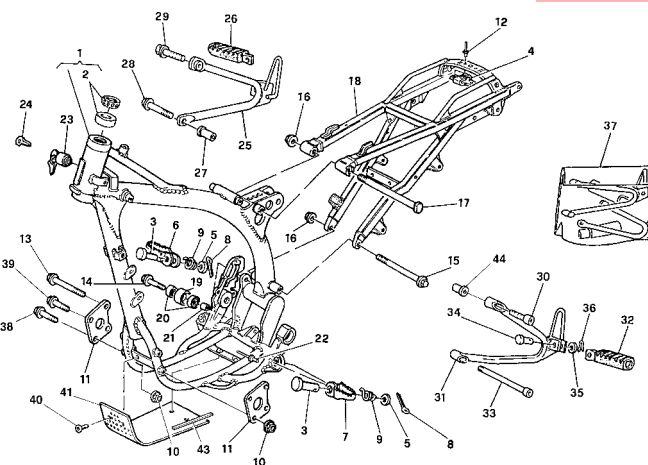

Pagina - Page - Page - Seite - Paja

53





Tavola - Drawing - Table - Bild - Tabla

13

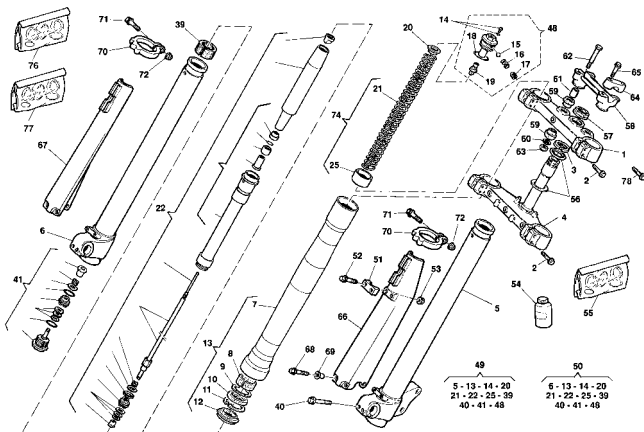

Pagina - Page - Page - Seite - Paja

57

Tavola - Drawing - Table - Bild - Tabla

14

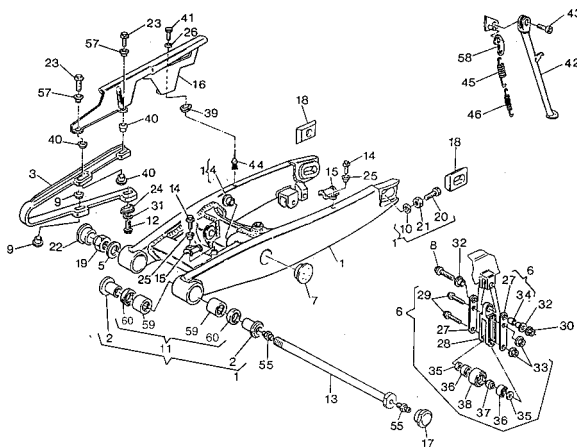

Pagina - Page - Page - Seite - Paja

61

Tavola - Drawing - Table - Bild - Tabla

15

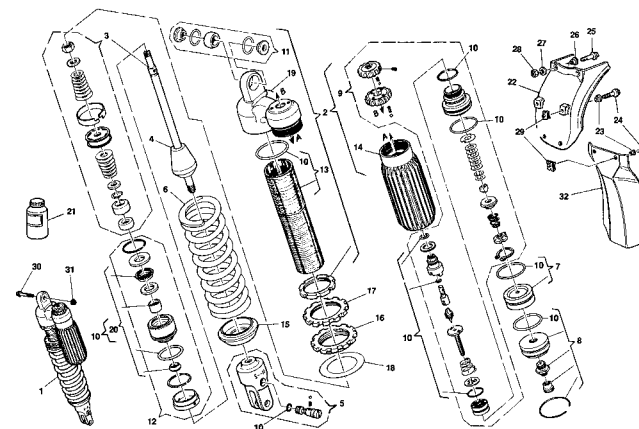

Pagina - Page - Page - Seite - Paja

65

Tavola - Drawing - Table - Bild - Tabla

16

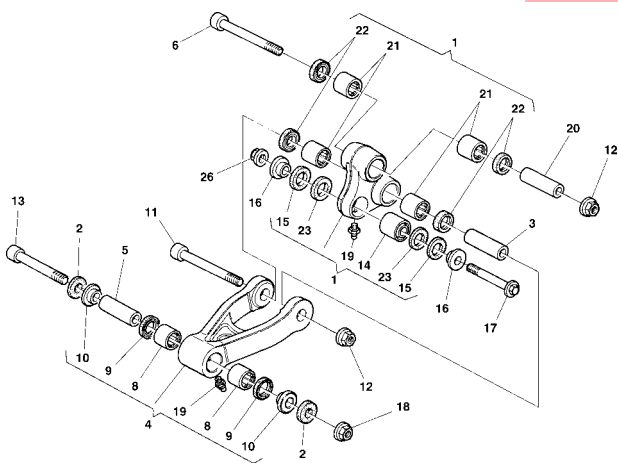

Pagina - Page - Page - Seite - Paja

69

Tavola - Drawing - Table - Bild - Tabla

17

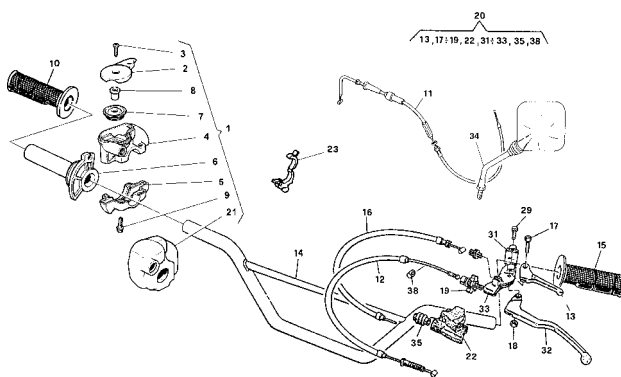

Pagina - Page - Page - Seite - Paja

71

Tavola - Drawing - Table - Bild - Tabla

18

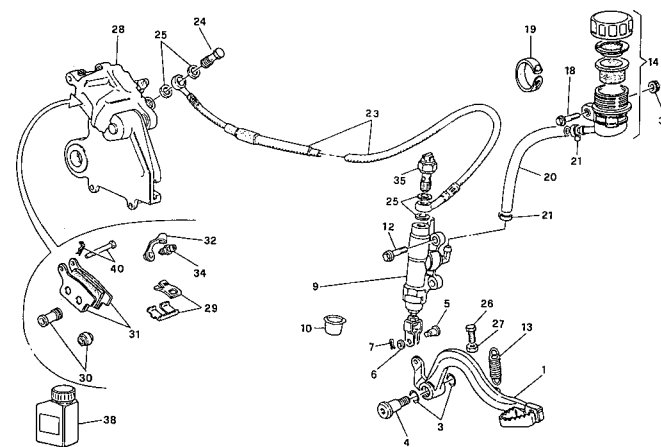

Pagina - Page - Page - Seite - Paja

75



Tavola - Drawing - Table - Bild - Tabla

19

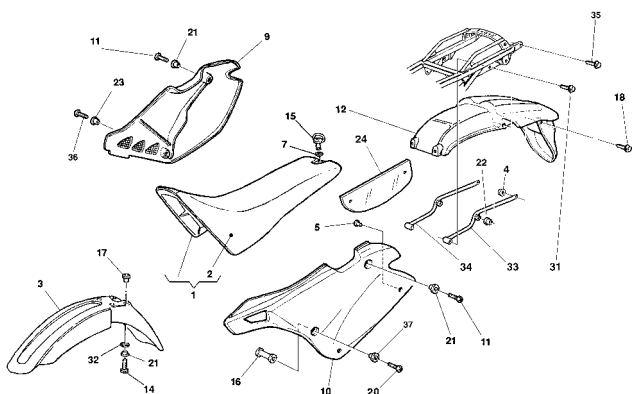

Pagina - Page - Page - Seite - Paja

77

Tavola - Drawing - Table - Bild - Tabla

20

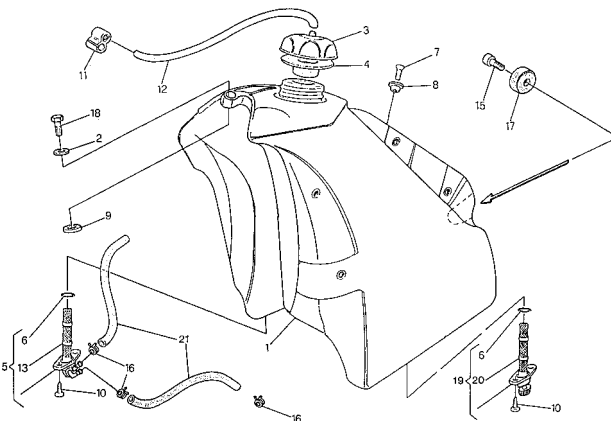

Pagina - Page - Page - Seite - Paja

79

Tavola - Drawing - Table - Bild - Tabla

21

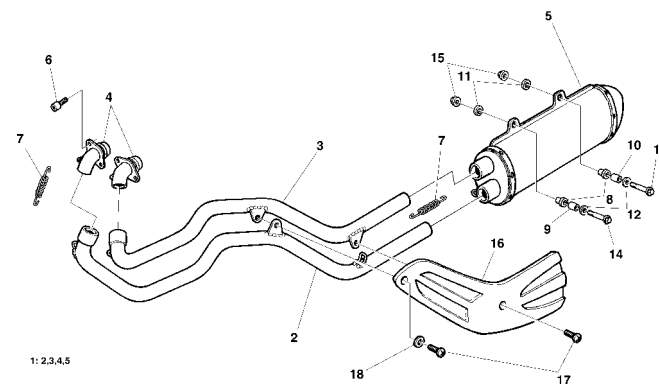

Pagina - Page - Page - Seite - Paja

81

Tavola - Drawing - Table - Bild - Tabla

22

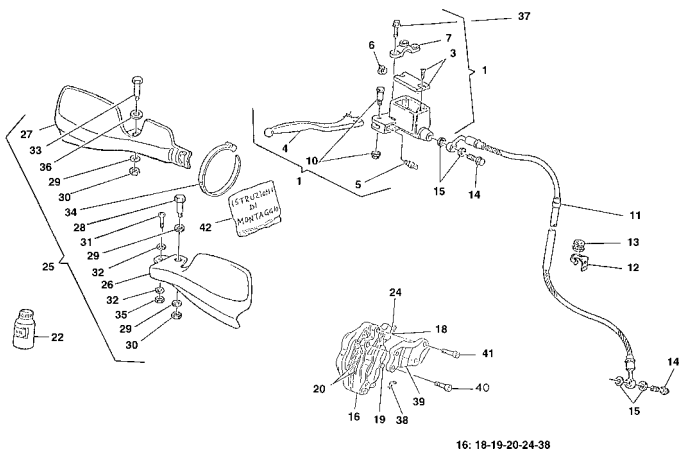

Pagina - Page - Page - Seite - Paja

83

Tavola - Drawing - Table - Bild - Tabla

22A

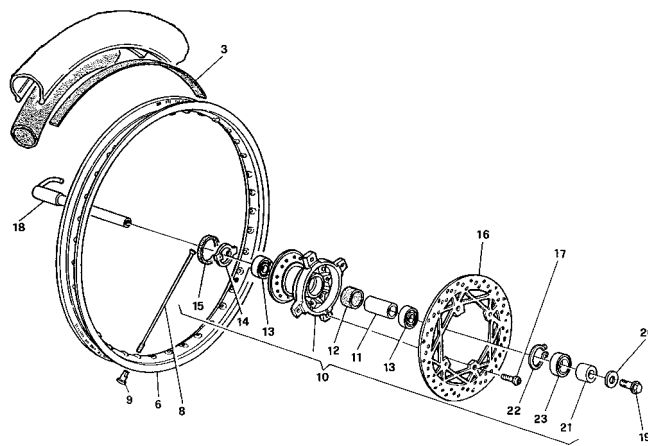

Pagina - Page - Page - Seite - Paja

87

Tavola - Drawing - Table - Bild - Tabla

23

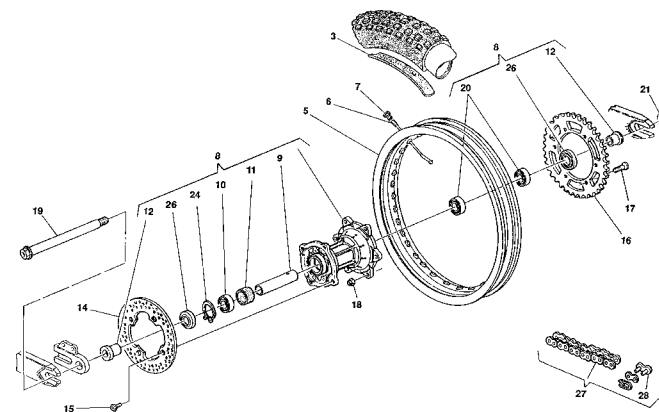

Pagina - Page - Page - Seite - Paja

89





SM 610 R/2000

INDICE – INDEX – INDEX – INHALTSVERZEICHNIS - INDICE

Tavola - Drawing - Table - Bild - Tabla

24

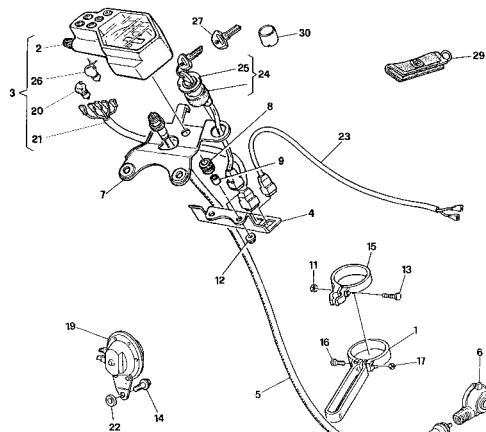

Pagina - Page - Page - Seite - Paja

93

Tavola - Drawing - Table - Bild - Tabla

25

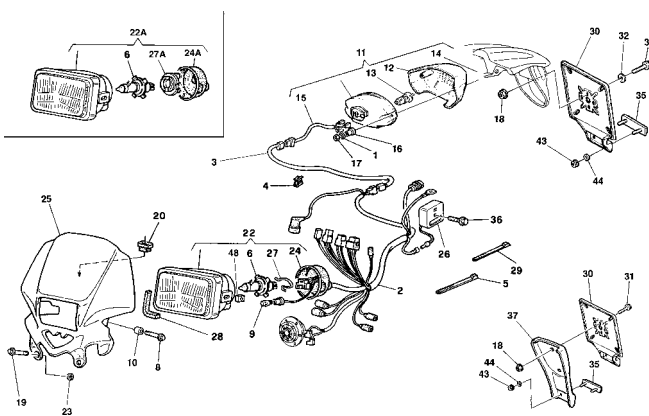

Pagina - Page - Page - Seite - Paja

95

Tavola - Drawing - Table - Bild - Tabla

26

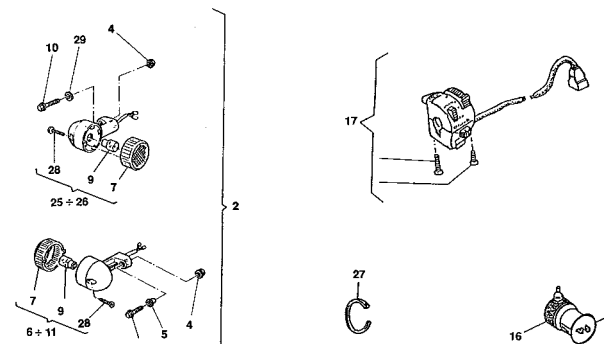

Pagina - Page - Page - Seite - Paja

99

Tavola - Drawing - Table - Bild - Tabla

27

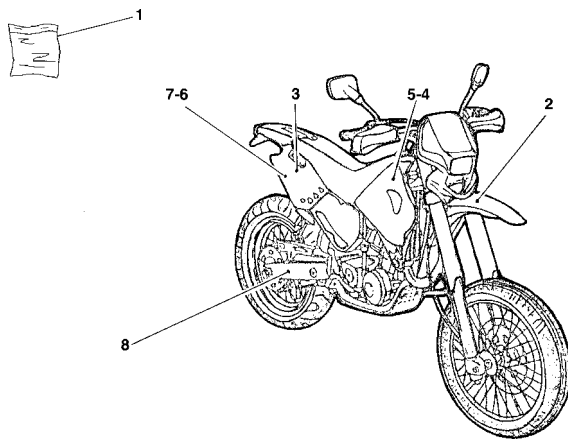

Pagina - Page - Page - Seite - Paja

101

**BLANK PAGE**

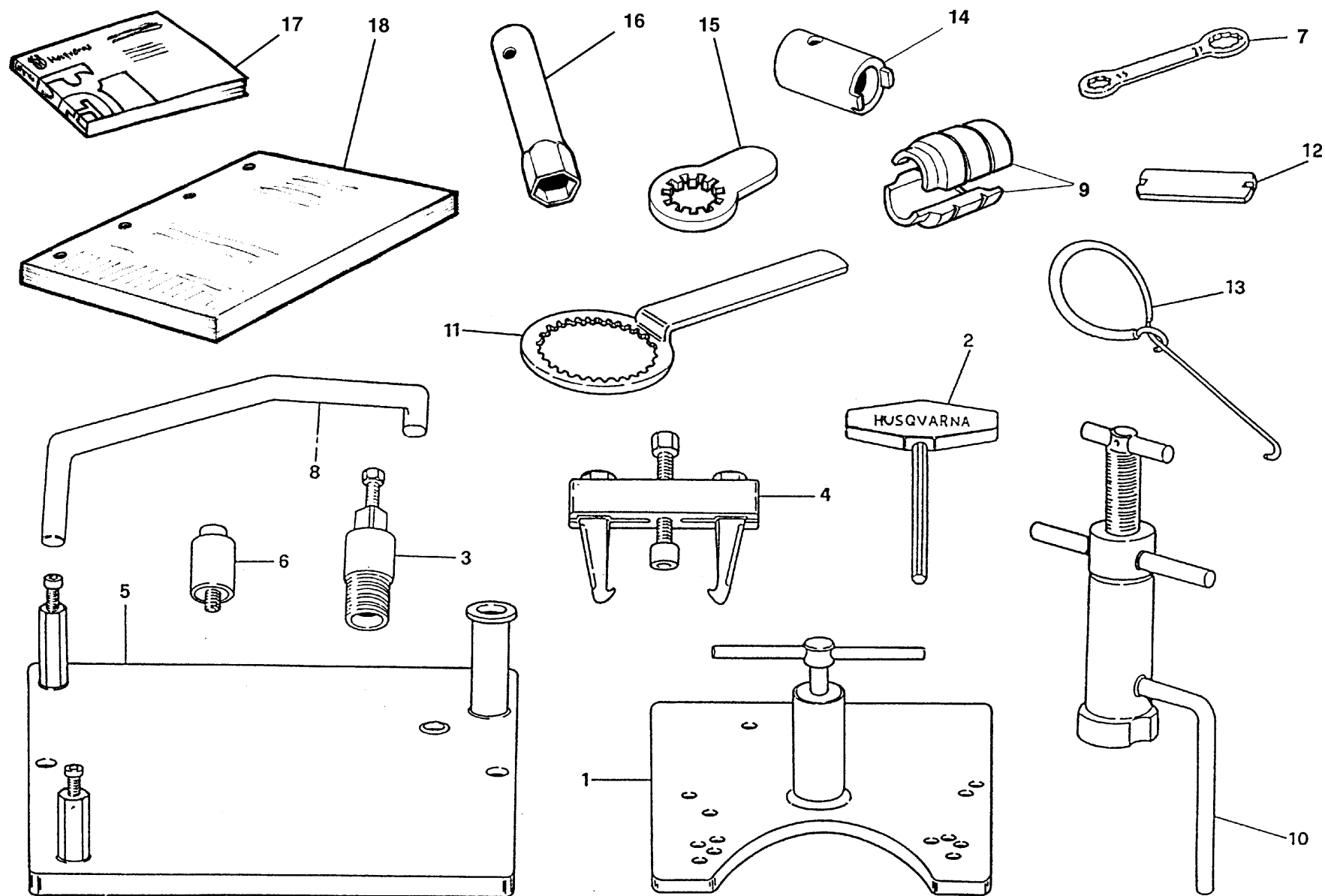



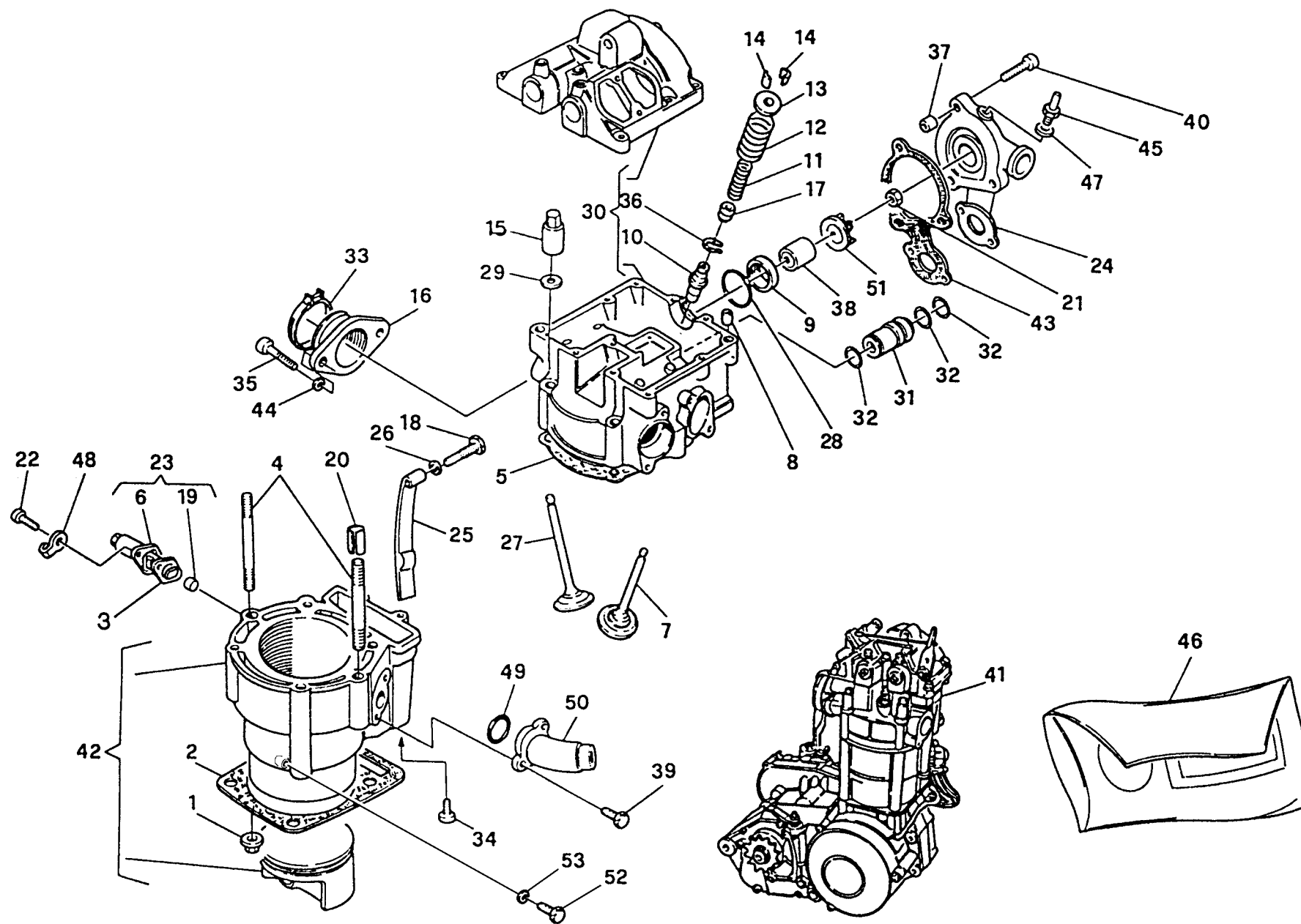





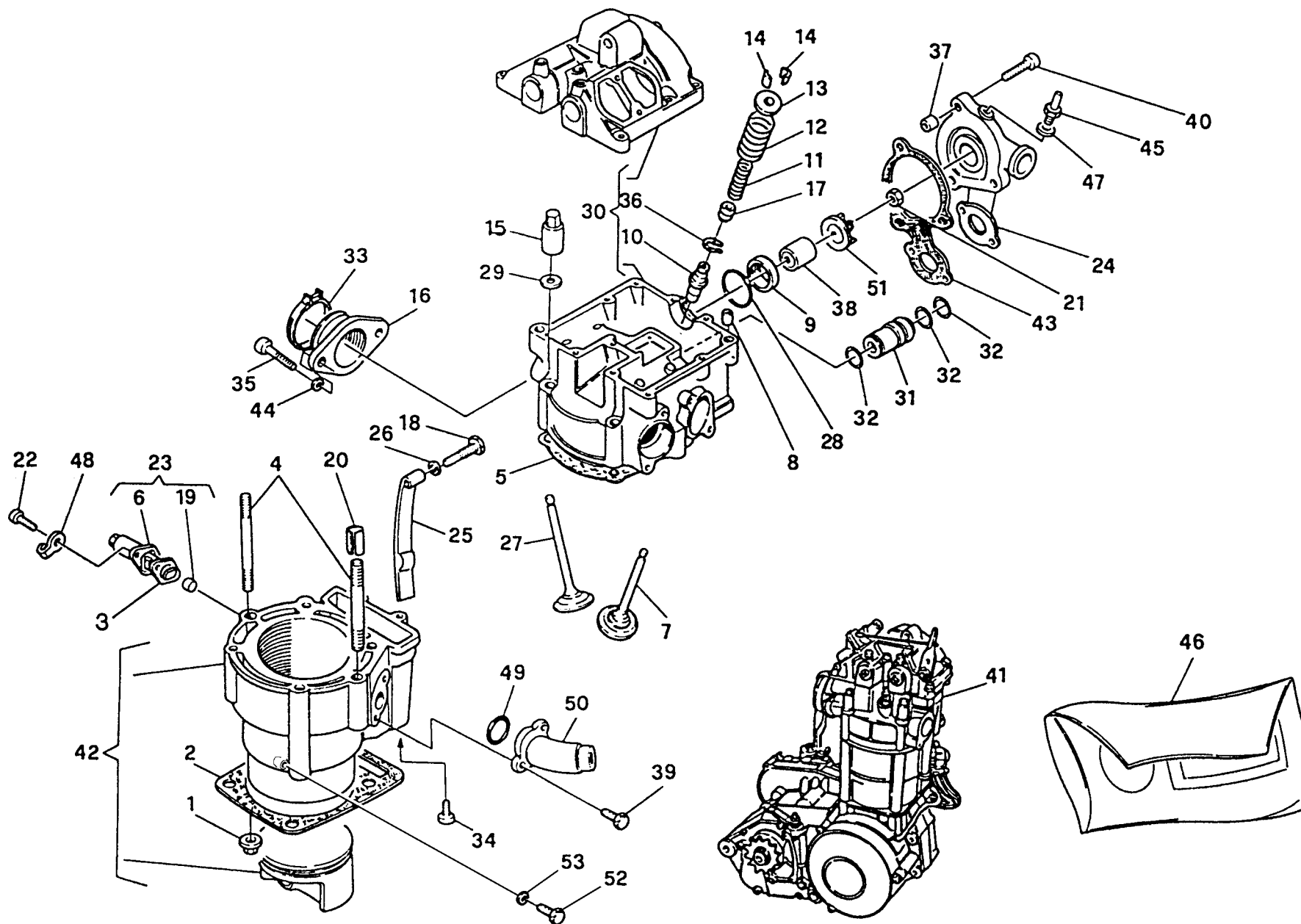



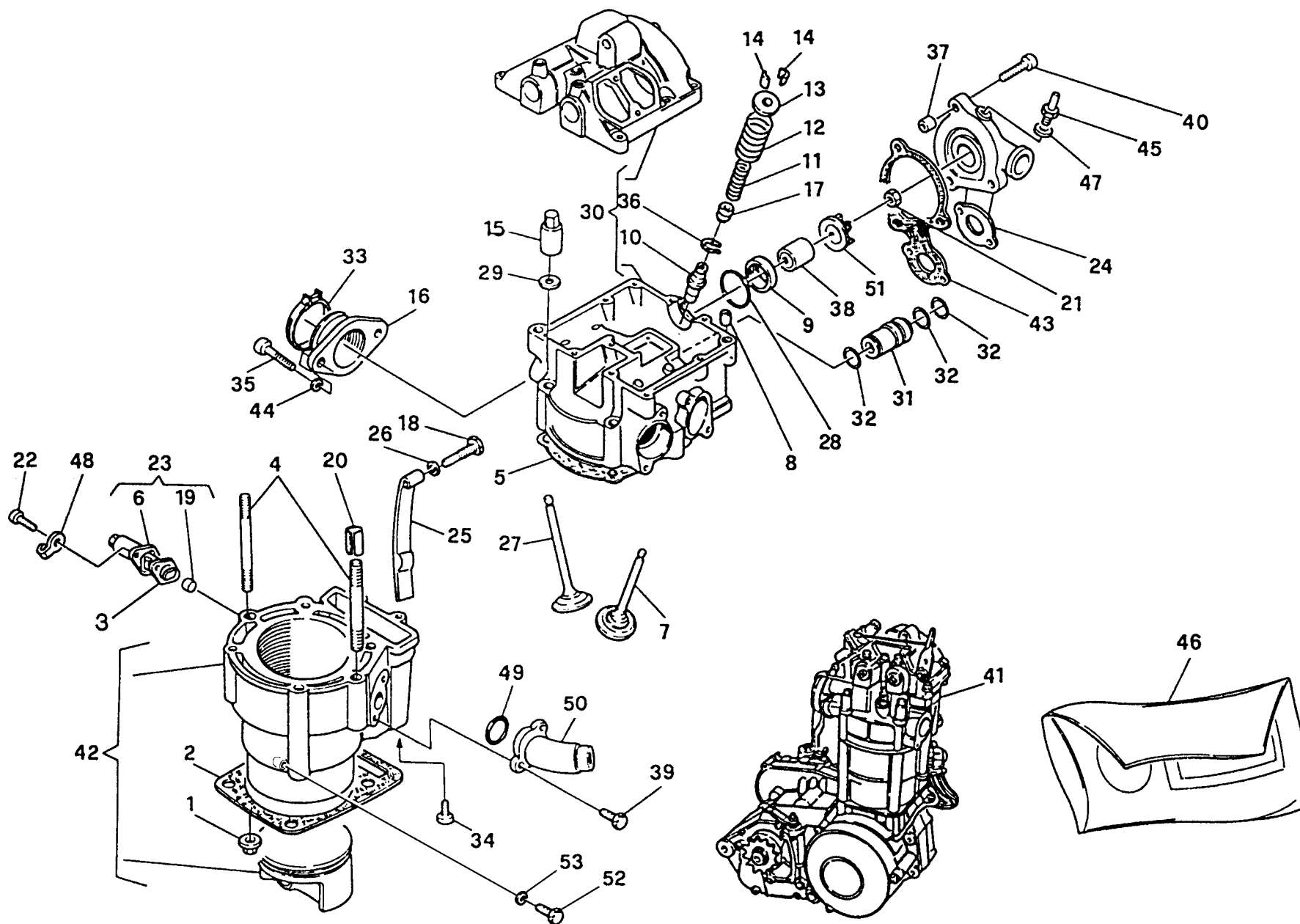



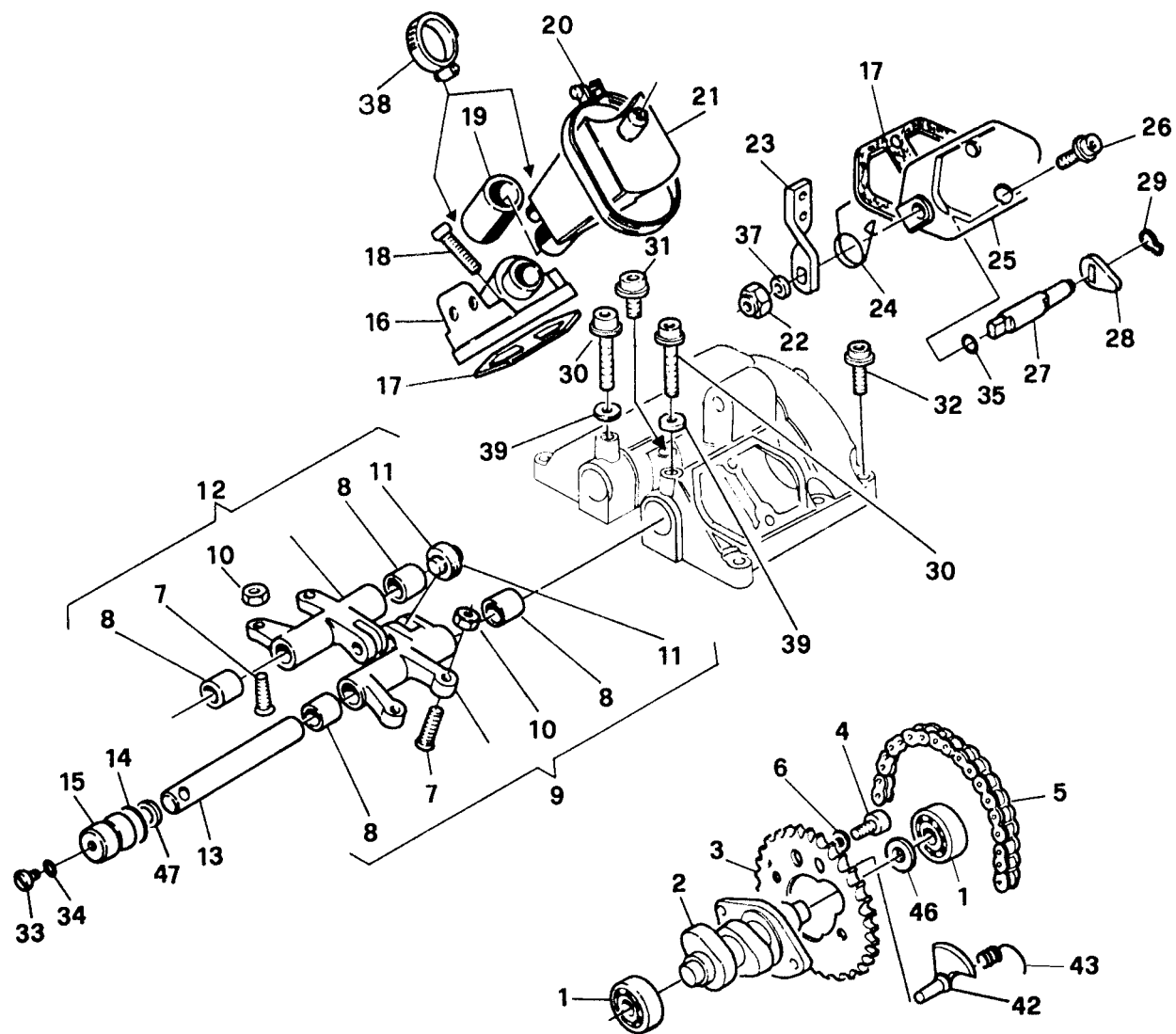

Note Notes Notes Marke Notas	Pos. No. N. Index Pos.	N. Cod. Code No. Nr. Code Code Nr N. Cod.	Q.tà Q.ty Q.te M.ge C.ad	DENOMINAZIONE	NAME	DESIGNATION	BESHREIBUNG	DENOMINACION	Validità Validity Validité Gültig Validez
	1	8000 02124	2	Cuscinetto (ø12xØ32x10 mm)	Bearing (ø12xØ32x10 mm)	Roulement (ø12xØ32x10 mm)	Lager (ø12xØ32x10 mm)	Cojinete (ø12xØ32x10 mm)	
	2	8000 73150	1	Albero a camme	Camshaft	Arbre distribution (610)	Nockenwelle (610)	Eje distribución (610)	
	3	8000 71028	1	Ingranaggio condotto (Z=36)	Driven gear (Z=36)	Engranage conduit (Z=36)	Zahnrad (Z=36)	Engranaje conducto (Z=36)	
	4	1615 26602	2	Vite	Screw	Vis	Schraube	Tornillo	
	5	8A00 35794	1	Catena distribuzione	Chain	Chaîne	Kette	Cadena	
	6	62N1 15658	2	Rosetta elastica	Spring washer	Rondelle élastique	Federscheibe	Arandela elástica	
	7	1615 04901	4	Vite di registro	Adjusting screw	Vis de réglage	Verstellungsschraube	Tornillo de regulación	
	8	1615 04301	4	Bussola	Bushing	Douille	Buchse	Manguito	
	9	1615 09601	1	Bilancere di scarico completo	Exhaust rocker-arm assy	Culbuteur échappement compl.	Kipphebel Auspuffrohr kpl.	Balancín de escape compl.	
	10	1615 15601	4	Dado	Nut	Ecrou	Mutter	Tuerca	
	11	1615 04501	2	Cuscinetto a rullini	Needle bearing	Roulement à aiguilles	Nadelkäfig	Cojinete de rodillos	
	12	1615 09501	1	Bilancere di aspirazione compl.	Inlet rocker-arm assy	Culbuteur d'aspiration compl.	Kipphebel Ansaugen kpl.	Balancín de aspiración compl.	
	13	1615 04201	2	Perno	Pin	Pivot	Bolzen	Perno	
	14	8000 59939	2	Anello OR	O-Ring	Bague OR	O-Ring	Anillo OR	
	15	1615 39301	2	Tappo	Plug	Bouchon	Verschluss	Tapón	
	16	80B0 84174	1	Coperchio registri	Cover	Couvercle	Deckel	Tapa	
	17	1615 03601	2	Guarnizione	Gasket	Garnitue	Dichtung	Junta	
	18	8000 62728	3	Vite	Screw	Vis	Schraube	Tornillo	
	19	1615 14104	1	Tubetto	Tube	Tuyau	Rohr	Tubo	
	20	8000 37299	1	Fascetta	Clamp	Collier	Schelle	Banda	
	21	1615 12802	1	Contenitore vapori basamento	Crankcase vapours cup	Cuve vapeurs carter	Dampfgefäß im Kurbelgehäuse	Contenedor vapores cárter	
	22	61N1 15195	1	Dado	Nut	Ecrou	Mutter	Tuerca	
	23	1615 40802	1	Leva	Lever	Levier	Hebel	Palanca	
	24	1615 12301	1	Molla	Spring	Ressort	Feder	Resorte	
	25	80B0 84173	1	Coperchio decompressore	Cover	Couvercle	Deckel	Tapa	



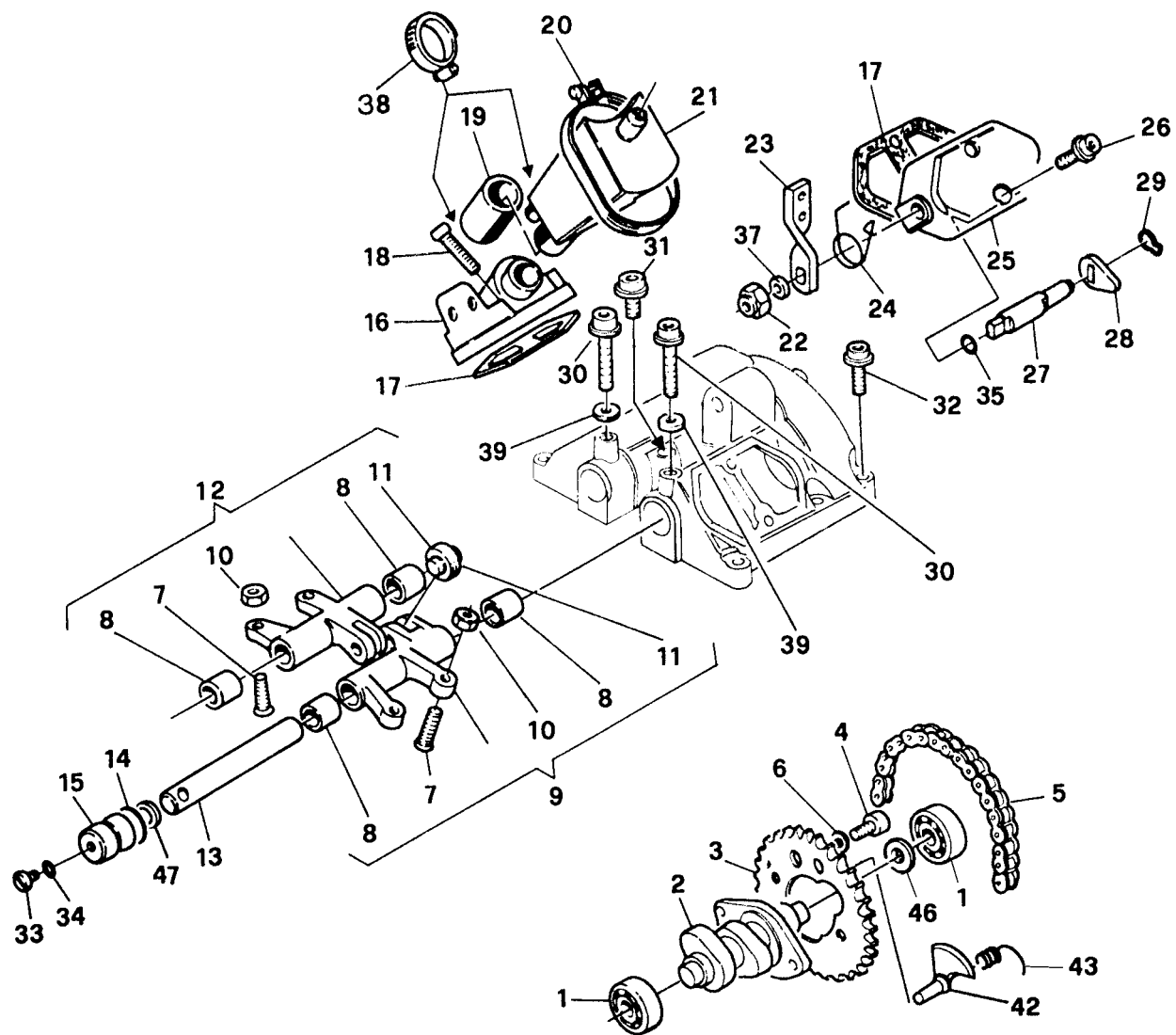



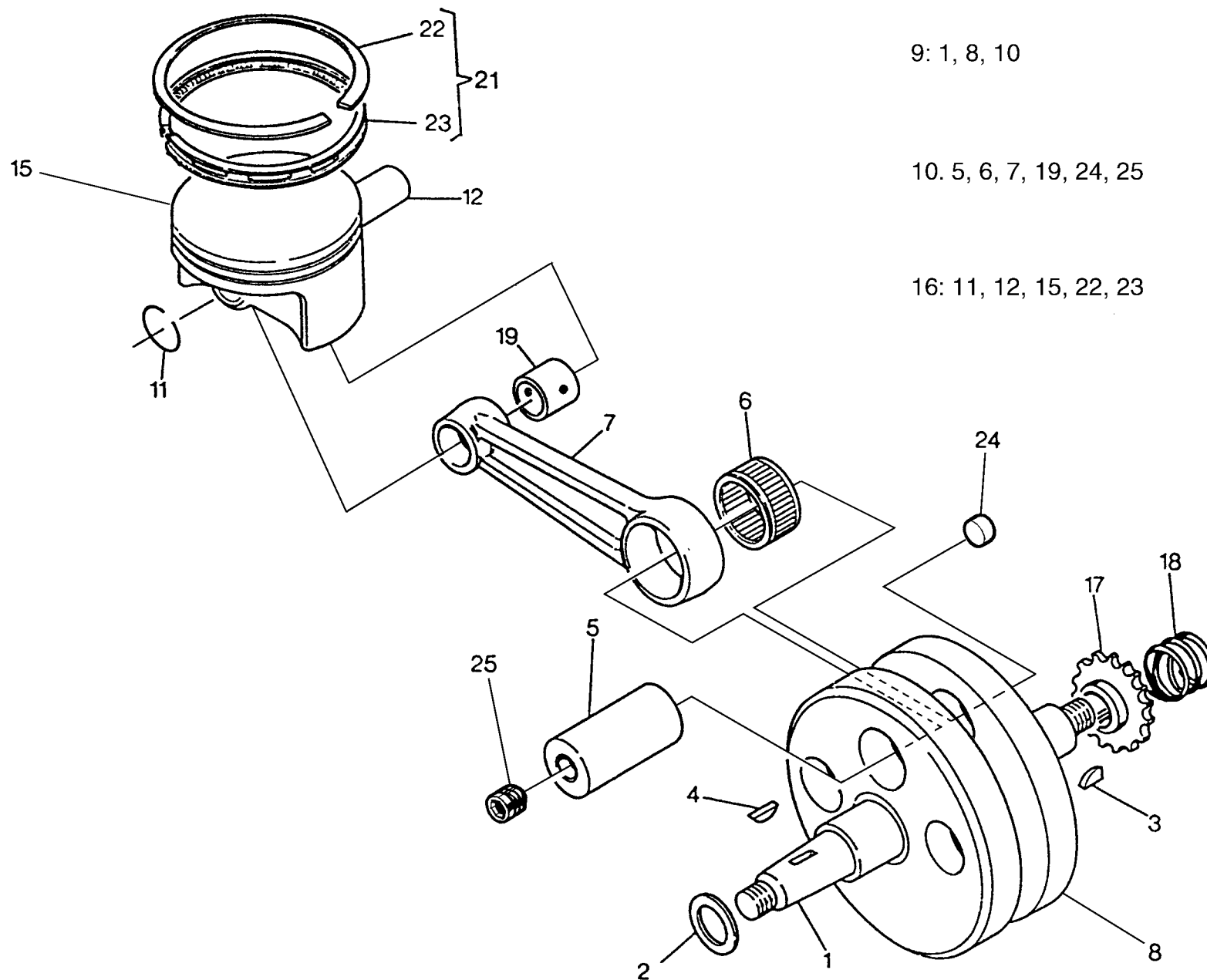





Note Notes Notes Marka Notas	Pos. No. N. Index Pos.	N. Cod. Code No. Nr. Code Code Nr N. Cod.	Q.tà Q.ty Q.te M.ge C.ad	DENOMINAZIONE	NAME	DESIGNATION	BESHREIBUNG	DENOMINACION	Validità Validity Validité Gültig Validez
	1	8000 87119	1	Radiatore Dx. completo	R.H. radiator compl.	Radiateur D. compl.	R., Kühler kpl.	Radiador derech. compl.	
	2	8000 79077	1	Tappo	Plug	Bouchon	Verschluss	Tapón	
	3	8000 87120	1	Radiatore Sx.	L.H. radiator	Radiateur G.	L., Kühler	Radiador izrdo.	
	4	8000 43715	1	Tubetto sfiato	Tube	Tuyau	Rohr	Tubo	
	6	8000 62725	2	Vite	Screw	Vis	Schraube	Tornillo	
	7	8000 59802	2	Bussola	Bushing	Douille	Buchse	Manguito	
	8	8000 59803	4	Gommino	Rubber pad	Pièce caoutchouc	Gummistück	Junta de goma	
	9	8000 59801	2	Rosetta piana	Washer	Rondelle	Scheibe	Arandela	
	10	8000 62728	2	Vite	Screw	Vis	Schraube	Tornillo	
	12	8000 66850	1	Tubo	Pipe	Tuyau	Schlauch	Tubo	
	13	8000 57242	2	Fascetta	Clamp	Collier	Schelle	Banda	
	14	8A00 66851	1	Tubo cilindro radiatori	Pipe	Tuyau	Schlauch	Tubo	
	15	8000 68666	6	Fascetta	Clamp	Collier	Schelle	Banda	
	16	8000 67610	1	Fascetta	Clamp	Collier	Schelle	Banda	
	17	8000 87859	1	Anello di guida	Ring	Bague	Ring	Anillo	
	18	8000 67449	1	Gommino	Rubber pad	Pièce caoutchouc	Gummistück	Junta de goma	
	19	80H0 87061	1	Convogliatore Dx.	Right side panel	Flanc droit	Rechte Flanke	Lateral derecho	
	20	80H0 87062	1	Convogliatore Sx.	Left side panel	Flanc gauche	Linke Flanke	Lateral izquierdo	
	21	80A0 67248	1	Griglia	Grille	Grille	Gitter	Parilla	
	22	80A0 67248	1	Griglia	Grille	Grille	Gitter	Parilla	
	23	8000 60873	4	Dado a graffetta	Nut	Ecrou	Mutter	Tuerca	
	24	8000 76069	2	Boccola	Bush	Douille	Buchse	Casquillo	
	25	8000 62729	2	Vite	Screw	Vis	Schraube	Tornillo	
	26	8000 62725	2	Vite	Screw	Vis	Schraube	Tornillo	
	27	8000 62725	1	Vite	Screw	Vis	Schraube	Tornillo	
	28	62N1 15519	1	Rosetta piana	Washer	Rondelle	Scheibe	Arandela	



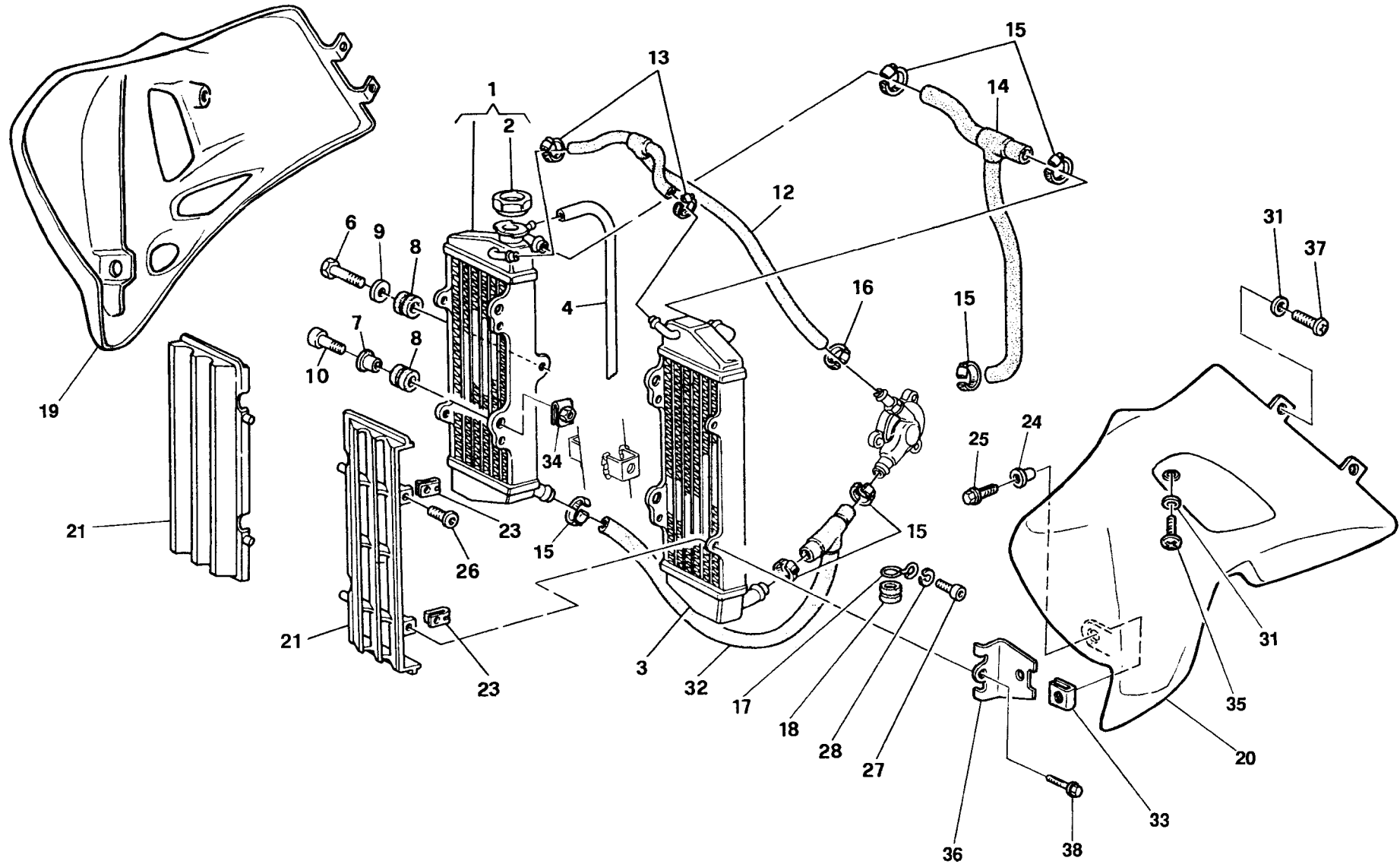



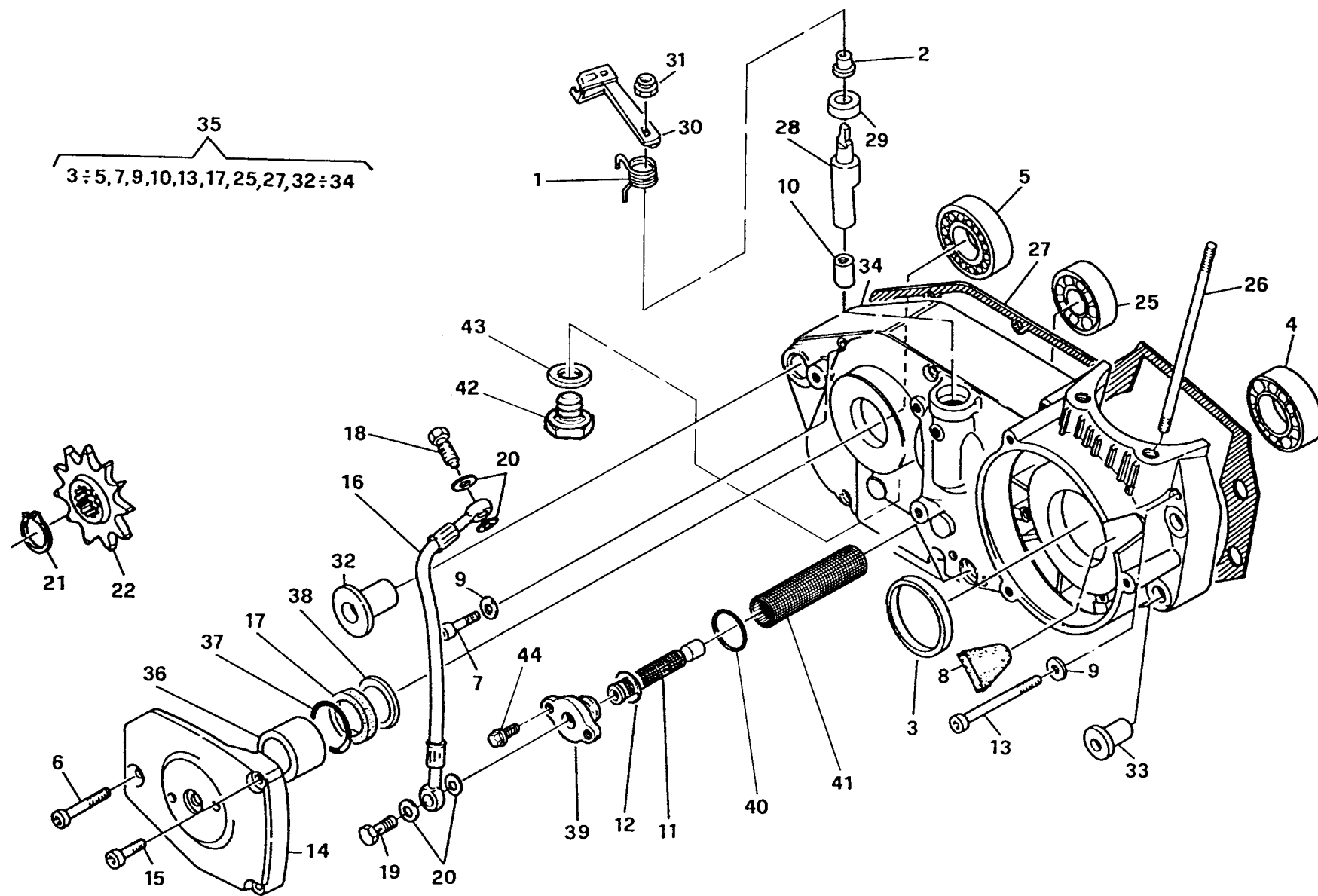

Note Notes Notes Marke Notas	Pos. No. Index	N. Cod. Code No. Nr. Code Code Nr N. Cod.	Q.tà Q.ty Q.te M.ge C.ad	DENOMINAZIONE	NAME	DESIGNATION	BESHREIBUNG	DENOMINACION	Validità Validity Validité Gültig Validez
	1	8A00 48188	1	Molla	Spring	Ressort	Feder	Resorte	
	2	8A00 55532	1	Bussola	Bushing	Douille	Buchse	Manguito	
	3	1513 72602	1	Anello di tenuta (ø30xØ52x7 mm)	Seal ring (ø30xØ52x7 mm)	Bague d'étanchéité (ø30xØ52x7 mm)	Dichtungsring (ø30xØ52x7 mm)	Anillo de retención (ø30xØ52x7 mm)	
	4	8000 28182	1	Cuscinetto (ø30xØ72x19 mm)	Bearing (ø30xØ72x19 mm)	Roulement (ø30xØ72x19 mm)	Lager (ø30xØ72x19 mm)	Cojinete (ø30xØ72x19 mm)	
	5	8000 43789	1	Cuscinetto (ø25xØ52x15 mm)	Bearing (ø25xØ52x15 mm)	Roulement (ø25xØ52x15 mm)	Lager (ø25xØ52x15 mm)	Cojinete (ø25xØ52x15 mm)	
	6	60N1 02513	1	Vite	Screw	Vis	Schraube	Tornillo	
	7	60N1 02520	6	Vite (M6x75 mm)	Screw (M6x75 mm)	Vis (M6x75 mm)	Schraube (M6x75 mm)	Tornillo (M6x75 mm)	
	8	1614 72801	1	Gommino	Rubber pad	Pièce caoutchouc	Gummistück	Junta de goma	
	9	62N1 15504	9	Rosetta piana	Washer	Rondelle	Scheibe	Arandela	
	10	8000 68195	1	Bussola	Bushing	Douille	Buchse	Manguito	
	11	8000 72427	1	Filtro olio interno	Internal oil filter	Filtre à huile	Ölfilter	Filtro aceite	
	12	8000 26884	1	Anello di tenuta	Seal ring	Bague d'étanchéité	Dichtungsring	Anillo de retención	
	13	60N1 02515	2	Vite (M6x50 mm)	Screw (M6x50 mm)	Vis (M6x50 mm)	Schraube (M6x50 mm)	Tornillo (M6x50 mm)	
	14	1611 81604	1	Coperchio	Cover	Couvercle	Deckel	Tapa	
	15	60N1 02510	2	Vite	Screw	Vis	Schraube	Tornillo	
	16	8000 65653	1	Tube	Pipe	Tuyau	Schlauch	Tube	
	17	8000 59977	1	Anello di tenuta (ø32xØ40x5 mm)	Seal ring (ø32xØ40x5 mm)	Bague d'étanchéité (ø32xØ40x5 mm)	Dichtungsring (ø32xØ40x5 mm)	Anillo de retención (ø32xØ40x5 mm)	
	18	8000 91743	1	Vite	Screw	Vis	Schraube	Tornillo	
	19	8000 45183	1	Vite	Screw	Vis	Schraube	Tornillo	
	20	8000 21480	4	Rosetta	Washer	Rondelle	Scheibe	Arandela	
	21	66N0 21211	1	Anello di fermo	Stop ring	Bague d'arrêt	Haltering	Anillo de retención	
S	22	8000 63832	1	Pignone (Z=17)	Pinion (Z=17)	Pignon (Z=17)	Ritzel (Z=17)	Piñón (Z=17)	
R	22	8000 63830	1	Pignone (Z=15)	Pinion (Z=15)	Pignon (Z=15)	Ritzel (Z=15)	Piñón (Z=15)	
	25	8000 19768	1	Cuscinetto (ø15xØ42x13 mm)	Bearing (ø15xØ42x13 mm)	Roulement (ø15xØ42x13 mm)	Lager (ø15xØ42x13 mm)	Cojinete (ø15xØ42x13 mm)	

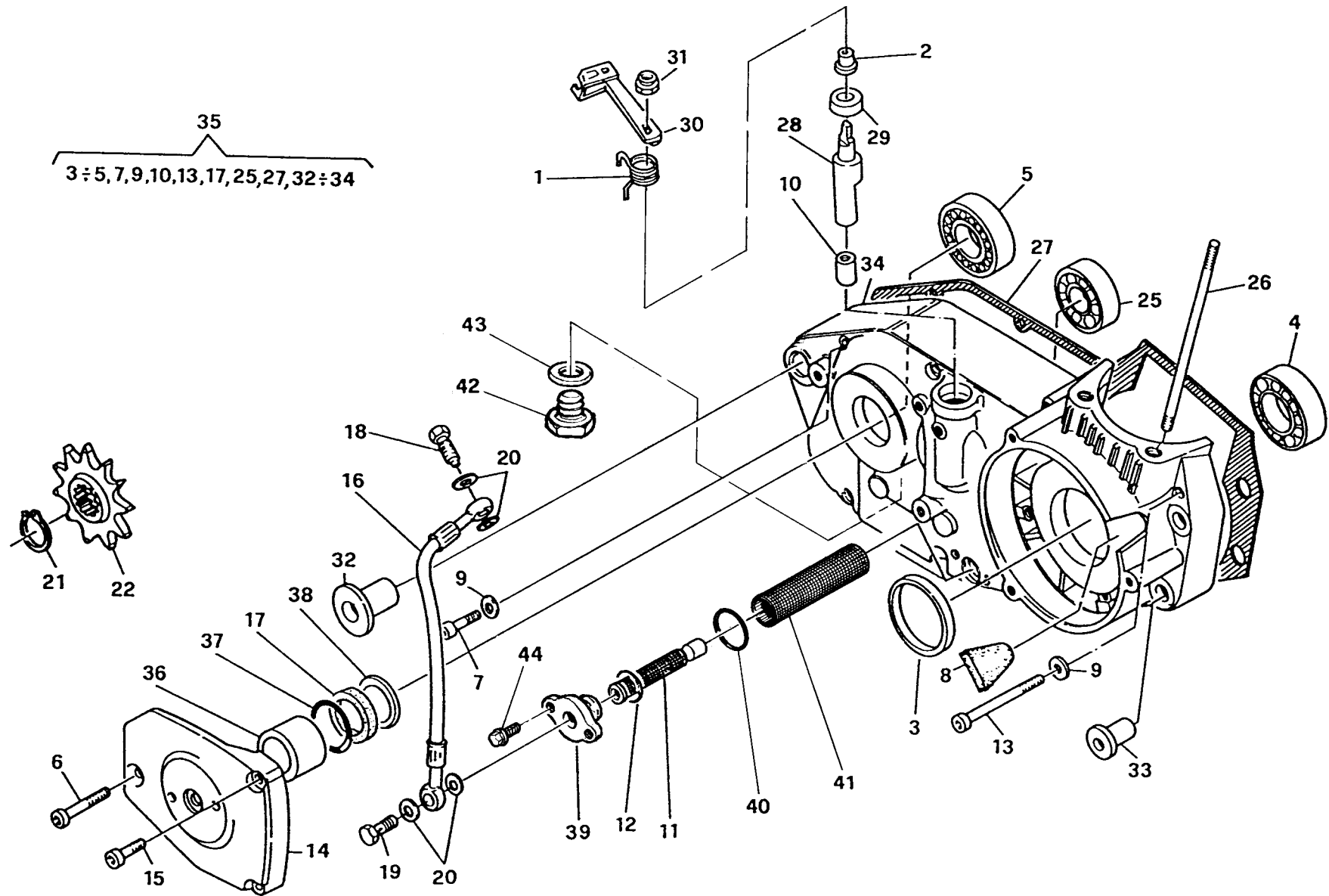



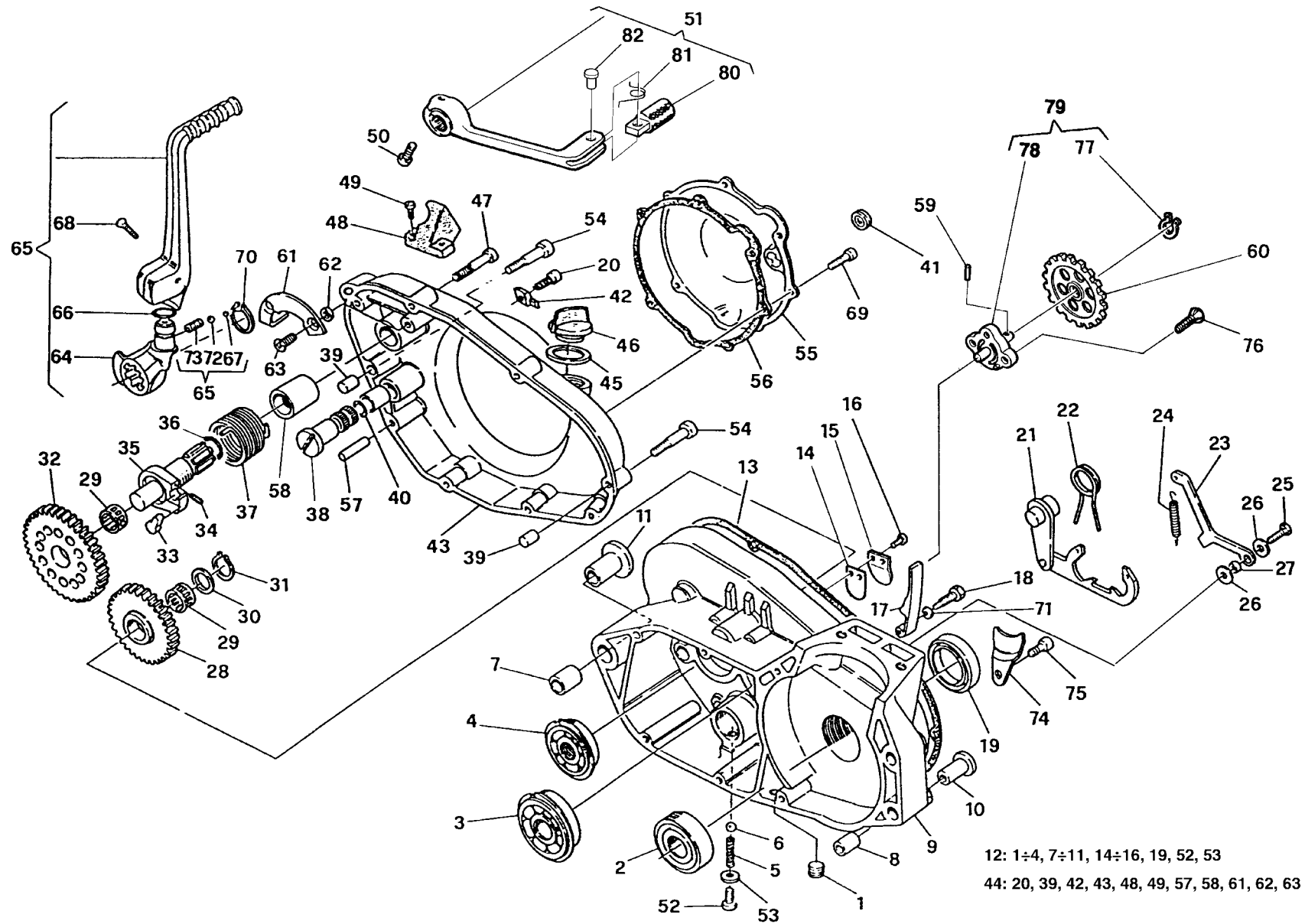

Note Notes Notes Marke Notas	Pos. No. Index	N. Cod. Code No. Nr. Code Code Nr N. Cod.	Q.tà Q.ty Q.te M.ge C.ad	DENOMINAZIONE	NAME	DESIGNATION	BESHREIBUNG	DENOMINACION	Validità Validity Validité Gültig Validez
	1	8000 69769	1	Tappo	Plug	Bouchon	Verschluss	Tapón	
	2	8A00 28182	1	Cuscinetto (ø30xØ72x19 mm)	Bearing (ø30xØ72x19 mm)	Roulement (ø30xØ72x19 mm)	Lager (ø30xØ72x19 mm)	Cojinete (ø30xØ72x19 mm)	
	3	8000 59975	1	Cuscinetto (ø25xØ52x15 mm)	Bearing (ø25xØ52x15 mm)	Roulement (ø25xØ52x15 mm)	Lager (ø25xØ52x15 mm)	Cojinete (ø25xØ52x15 mm)	
	4	8000 59976	1	Cuscinetto (ø17xØ47x14 mm)	Bearing (ø17xØ47x14 mm)	Roulement (ø17xØ47x14 mm)	Lager (ø17xØ47x14 mm)	Cojinete (ø17xØ47x14 mm)	
	5	8000 61263	1	Molla	Spring	Ressort	Feder	Resorte	
	6	8000 60476	1	Sfera	Ball	Bille	Kugel	Esfera	
	7	1614 59001	1	Bussola di riferimento	Bushing	Douille	Buchse	Manguito	
	8	1610 77601	1	Bussola di riferimento	Bushing	Douille	Buchse	Manguito	
	10	1610 77701	1	Bussola	Bushi.g	Douille	Buchse	Manguito	
	11	1614 58901	1	Bussola	Bushing	Douille	Buchse	Manguito	
	12	8000 89899	1	Carter motore accoppiati compl.	Crankcase assy	Carter compl.	Kurberlgehause kpl.	Carter motor completi	
	13	1611 65003	1	Guarnizione	Gasket	Garnitue	Dichtung	Junta	
	14	1615 34801	1	Valvola lamellare	Reed valve	Soupape lamellaire	Ventil lamellar	Válvula laminar	
	15	1615 10501	1	Supporto	Support	Support	Halterung	Soporte elástico	
	16	60N1 02866	2	Vite	Screw	Vis	Schraube	Tornillo	
	17	8000 68686	1	Tendicatena distr.	Chain adjuster	Tendeur de chaine	Kettenspanner	Tensor de cadena	
	18	1615 35902	1	Vite	Screw	Vis	Schraube	Tornillo	
	19	1513 72602	1	Anello di tenuta (ø30xØ52x7mm)	Seal ring (ø30xØ52x7mm)	Bague d'étanchéité (ø30xØ52x7mm)	Dichtungsring (ø30xØ52x7mm)	Anillo de retención (ø30xØ52x7mm)	
	20	8000 26970	1	Vite	Screw	Vis	Schraube	Tornillo	
	21	1611 68601	1	Selettore cambio	Selector	Selecteur	Waehler	Selector com.	
	22	1611 69201	1	Molla	Spring	Ressort	Feder	Resorte	
	23	8000 90054	1	Saltarello	Click	Cliquet	Strumhaken	Saltarelo	
	24	1611 68401	1	Molla	Spring	Ressort	Feder	Resorte	
	25	8000 47422	1	Vite	Screw	Vis	Schraube	Tornillo	
	26	8A00 37003	1	Rosetta piana	Washer	Rondelle	Scheibe	Arandela	
	27	1611 21601	1	Bussola	Bushing	Douille	Buchse	Manguito	
	28	1611 27101	1	Ingranaggio di rinvio (Z=25)	Gear (Z=25)	Engrantage (Z=25)	Zahnrad (Z=25)	Engranaje (Z=25)	



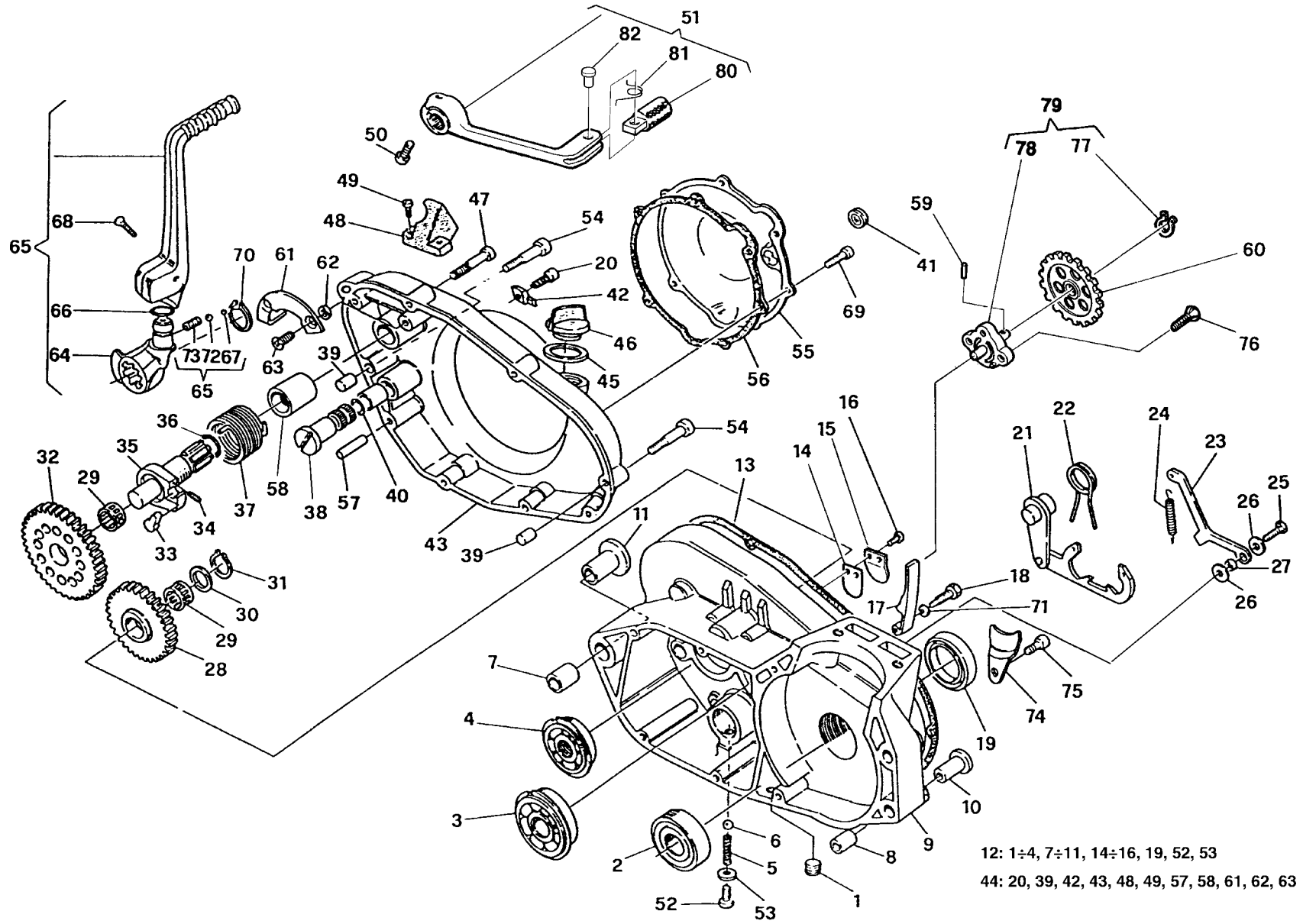

Note Notes Notes Mark Notas	Pos. No. Index Pos.	N. Cod. Code No. Nr. Code Code Nr N. Cod.	Q.tà Q.ty Q.te M.ge C.ad	DENOMINAZIONE	NAME	DESIGNATION	BESCHREIBUNG	DENOMINACION	Validità Validity Validité Gültig Validez
	29	8000 40449	2	Cuscinetto a rullini	Needle bearing	Roulement à aiguilles	Nadelkäfig	Cojinete de rodillos	
	30	8000 38110	1	Rosetta di rasamento(0,3 mm)	Washer (0,3 mm)	Rondelle (0,3 mm)	Scheibe (0,3 mm)	Arandela (0,3 mm)	
	30	8B00 38110	1	Rosetta di rasamento (0,5 mm)	Washer (0,5 mm)	Rondelle (0,5 mm)	Scheibe (0,5 mm)	Arandela (0,5 mm)	
	30	8F00 38110	1	Rosetta di rasamento (1,0 mm)	Washer (1,0 mm)	Rondelle (1,0 mm)	Scheibe (1,0 mm)	Arandela (1,0 mm)	
	31	66N0 21205	1	Anello di fermo	Stop ring	Bague d'arrêt	Haltering	Anillo de retención	
	32	1615 39101	1	Ingranaggio avviamento (Z=35)	Driven gear (Z=35)	Engrange conduit (Z=35)	Zahnrad (Z=35)	Engranaje conducto (Z=35)	
	33	1611 68001	1	Saltarello	Click	Cliquet	Strumhaken	Saltarello	
	34	1611 68101	1	Molla	Spring	Ressort	Feder	Resorte	
	35	1611 67702	1	Albero avviamento	Starter crank shaft	Arbre de démarrage	Kickstarterwelle	Eje arranque	
	36	8000 60475	2	Anello OR	O-Ring	Bague OR	O-Ring	Anillo OR	
	37	1616 36201	1	Molla	Spring	Ressort	Feder	Resorte	
	38	1611 74601	1	Albero pedale cambio	Gearbox pedal shaft	Arbre pédale change de vitesse	Pedal Umsteuerungswelle	Eje pedal cambio	
	39	1611 70801	2	Spina di riferimento	Pin	Goupille	Stift	Clavija	
	40	8000 60474	2	Anello OR	O-Ring	Bague OR	O-Ring	Anillo OR	
	41	8000 53340	1	Oblò	Inspection plug	Capuchon de inspection	Stopfen	Portilla	
	42	8000 68710	1	Gommino	Rubber pad	Pièce caoutchouc	Gummistück	Junta de goma	
	43	8A00 67194	1	Coperchio trasmissione	Cover	Couvercle	Deckel	Tapa	
	44	8A00 75764	1	Coperchio trasmissione compl.	Cover assy	Couvercle compl.	Deckel Kpl.	Tapa compl.	
	45	8000 27960	1	Guarnizione	Gasket	Garnitue	Dichtung	Junta	
	46	8000 36786	1	Tappo	Plug	Bouchon	Verschluss	Tapón	
	47	60N1 02512	5	Vite	Screw	Vis	Schraube	Tornillo	
	48	8000 68584	1	Tampone ferma pedale	Pad	Tampon	Stopfen	Tampón	
	49	60N1 02900	2	Vite	Screw	Vis	Schraube	Tornillo	
	50	60N1 02509	1	Vite	Screw	Vis	Schraube	Tornillo	
	51	8000 92944	1	Leva cambio compl.	Gearchange lever	Levier comm. vitesse	Schalthebel	Palanca del cambio	
	52	8000 66101	1	Vite	Screw	Vis	Schraube	Tornillo	
	53	8000 47763	1	Bussola	Bushing	Douille	Buchse	Manguito	
	54	60N1 02513	2	Vite	Screw	Vis	Schraube	Tornillo	
	55	8A00 67216	1	Coperchio	Cover	Couvercle	Deckel	Tapa	
	56	8000 68191	1	Guarnizione	Gasket	Garnitue	Dichtung	Junta	
	57	8000 60477	1	Spina di riferimento	Pin	Goupille	Stift	Clavija	
	58	1614 46901	1	Bussola	Bushing	Douille	Buchse	Manguito	

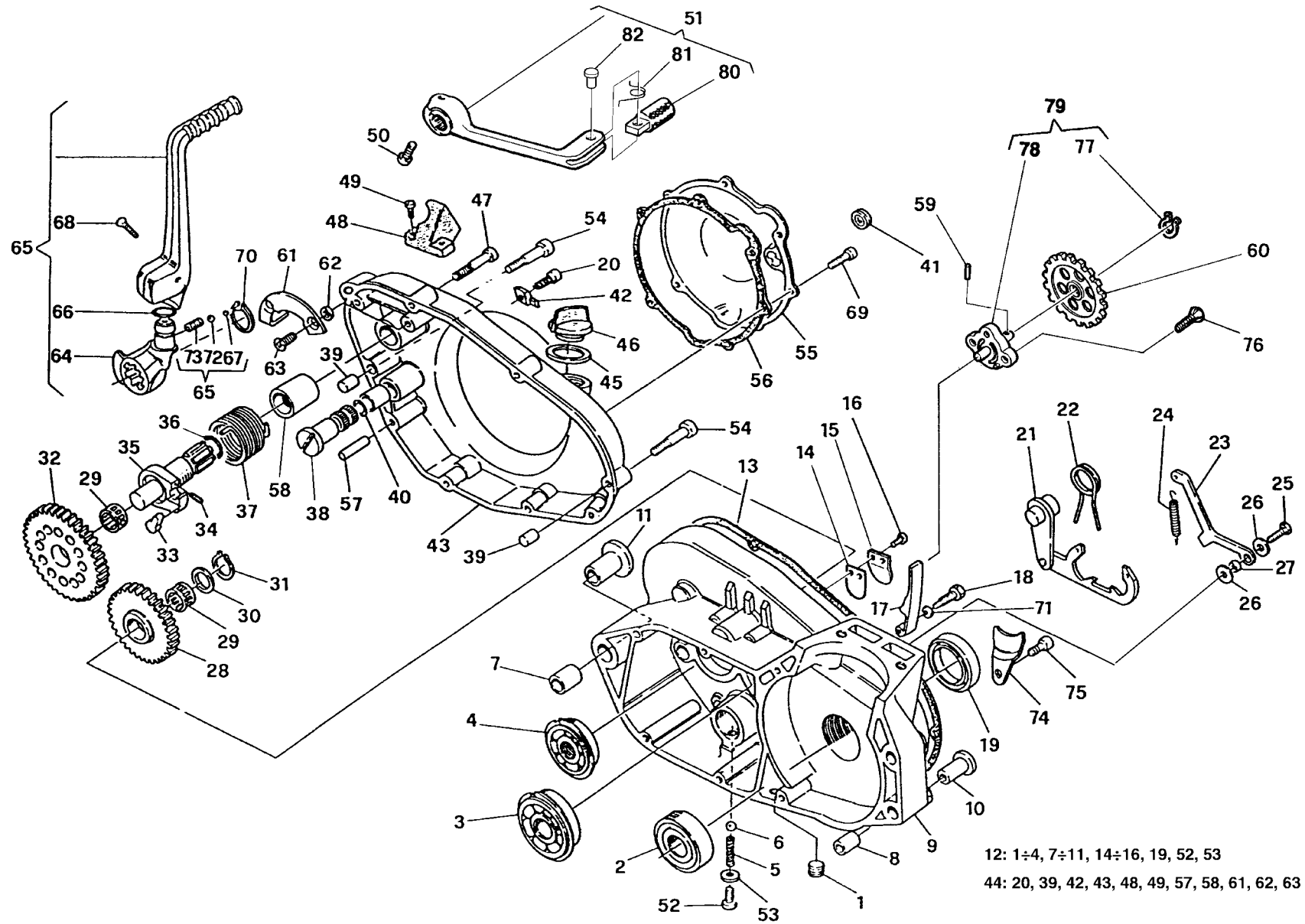

12: 1÷4, 7÷11, 14÷16, 19, 52, 53  
 44: 20, 39, 42, 43, 48, 49, 57, 58, 61, 62, 63



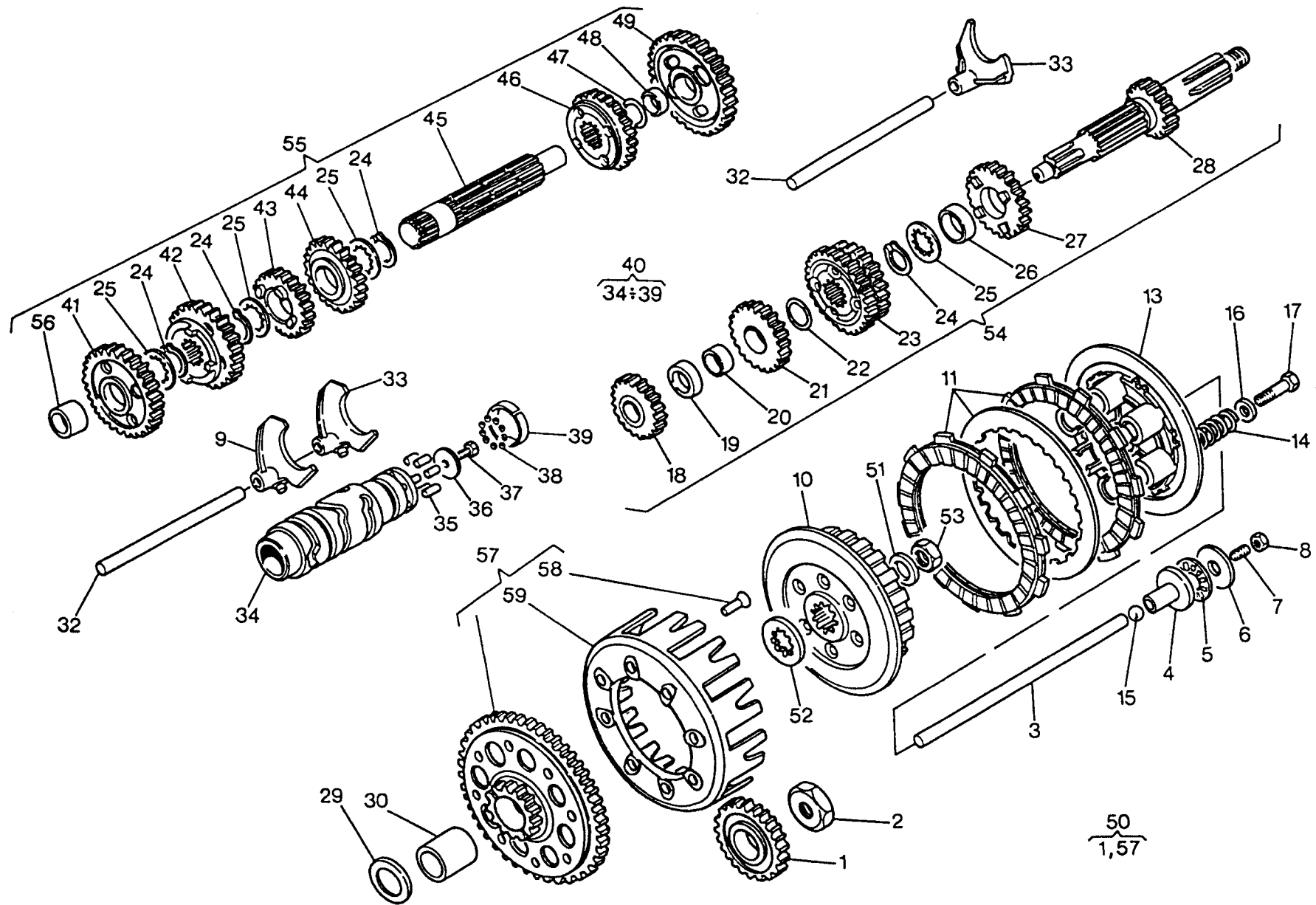

Note Notes Notas	Pos. No. Index	N. Cod. Code No. Nr. Code Code Nr N. Cod.	Q.tà Q.ty Q.te M.ge C.ad	DENOMINAZIONE	NAME	DESIGNATION	BESHREIBUNG	DENOMINACION	Validità Validity Validité Gültig Validez
	1	8000 69715	1	Ingranaggio conduttore	Driving gear	Engrage conducteur	Zahnrad	Engranaje conductor	
	2	8000 59965	1	Dado	Nut	Ecrou	Mutter	Tuerca	
	3	1615 31502	1	Asta di forza	Fork tube	Barre de force	Druckstab	Varilla de fuerza	
	4	8000 54477	1	Piattello	Plate	Plateau	Teller	Placa	
	5	8000 35780	1	Cuscinetto assiale	Bearing	Roulement	Kugellager	Cojinete	
	6	8000 35781	1	Rosetta	Washer	Rondelle	Scheibe	Arandela	
	7	8000 54692	1	Vite	Screw	Vis	Schraube	Tornillo	
	8	61N1 15062	1	Dado	Nut	Ecrou	Mutter	Tuerca	
	9	8000 63425	1	Forcella 3ª vel.	Fork	Fourche	Gabel	Horquilla	
	10	8A00 48137	1	Mozzo frizione	Hub	Moyeau	Radnabe	Cubo	
	11	8A00 88966	1	Ass. gruppo frizione (15 dischi: 8 conduttori+7 condotti)	Clutch group assy (15 disc:8 driving disc+ 7 driven disc)	Groupe embrayage compl. (15 disque:8 conducteur+ 7 conduites)	Kupplungsgruppe Kpl (15 Scheibe: 8 Belagssch.+ 7 Stahlsch.)	Grupo embrague compl. (15 discos:8 conductor+ 7 conducitos)	
	13	8000 48138	1	Piastra spingidischi	Plate	Plaque	Platte	Placa	
	14	8000 71230	5	Molla frizione	Clutch spring	Ressort embrayage	Kupplungsfeder	Resorte embrague	
	15	6BN0 21509	1	Sfera	Ball	Bille	Kugel	Esfera	
	16	8000 21535	5	Rosetta	Washer	Rondelle	Scheibe	Arandela	
	17	60N1 01081	5	Vite	Screw	Vis	Schraube	Tornillo	
	18	1612 36201	1	Ingranaggio 2ª A.P. (Z=16)	Main shaft 2nd gear (Z=16)	Engr. 2ème vitesse A.P.(Z=16)	Zahn. f. 2. (Z=16)	Engr.2º velocidad Eje P. (Z=16)	
	19	1612 48101	1	Distanziale	Spacer	Entretoise	Distanzstück	Separador	
	20	1612 48001	1	Bussola	Bushing	Douille	Buchse	Manguito	
	21	1612 36301	1	Ingranaggio 3ª A.P. (Z=19)	Main shaft 3rd gear (Z=19)	Engr. 3ème vitesse A.P. (Z=19)	Zahn. f. 3.(Z=19)	Engr. 3º velocidad Eje P.(Z=19)	
	22	1612 84201	1	Rosetta	Washer	Rondelle	Scheibe	Arandela	
	23	1612 39001	1	Ingran. 5ª e 6ª A.P. (Z=25/27)	Gear 5th - 6th speed (Z=25/27)	Engr. 5ème 6ème (Z=25/27)	Zahnrad 5. - 6. (Z=25/27)	Engr. 5º - 6º velocidad (Z=25/27)	
	24	66N0 21211	4	Anello di fermo	Stop ring	Bague d'arrêt	Haltering	Anillo de retención	
	25	1611 71701	4	Rosetta	Washer	Rondelle	Scheibe	Arandela	
	26	8000 63821	1	Bussola	Bushing	Douille	Buchse	Manguito	
	27	1611 83701	1	Ingranaggio 4ª A.P. (Z=23)	Main shaft 4th gear (Z=23)	Engr. 4ème vitesse A.P. (Z=23)	Zahn. f. 4. (Z=23)	Engr.4º velocidad Eje P.(Z=23)	
	28	8000 69736	1	Albero primario	Main shaft	Arbre primaire	Hauptwelle	Eje primario	
	29	8E00 30053	1	Rosetta di rasamento	Washer	Rondelle	Scheibe	Arandela	
	30	1615 38801	1	Bussola	Bushing	Douille	Buchse	Manguito	
	32	1611 69901	2	Perno	Pin	Pivot	Bolzen	Perno	

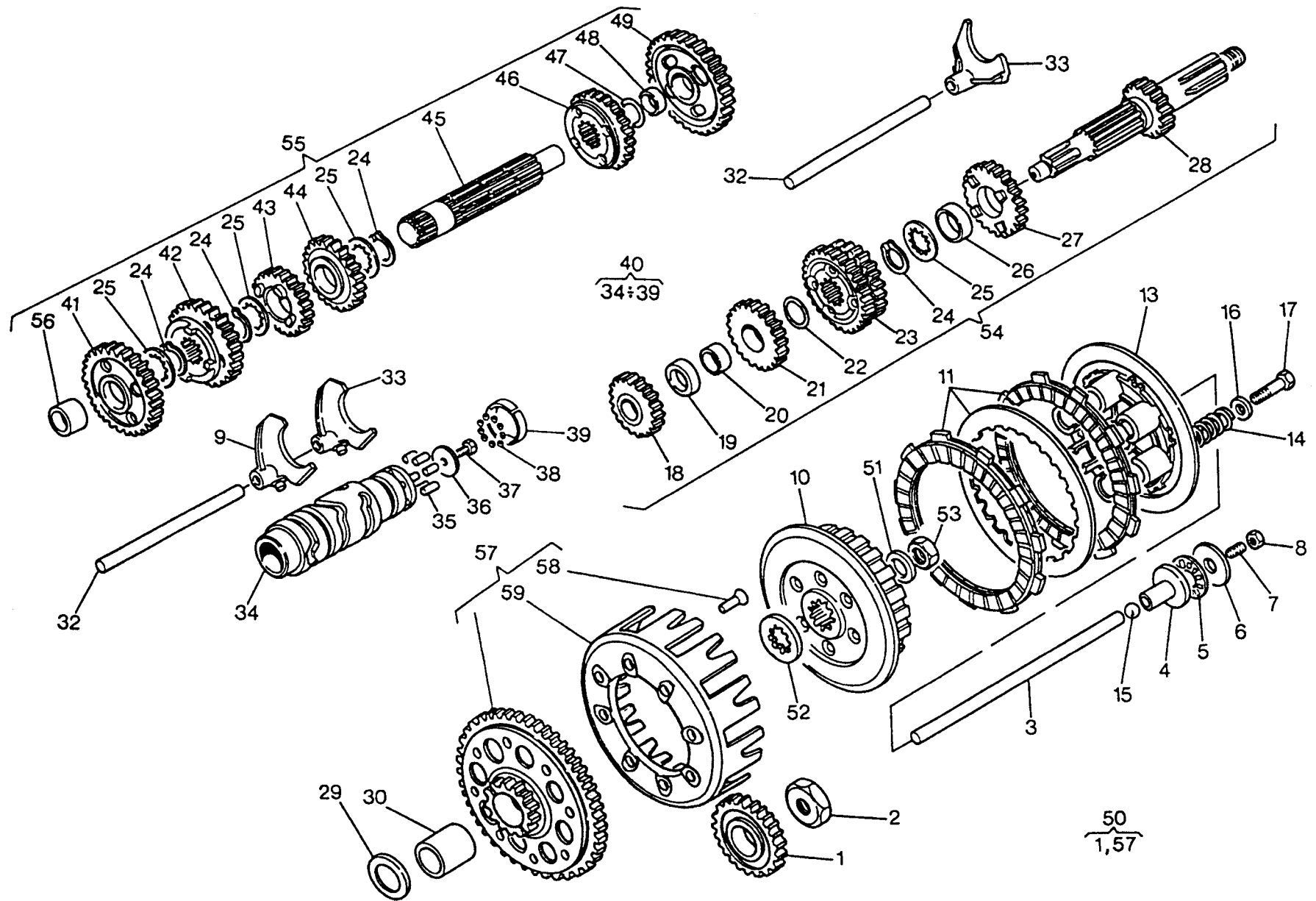







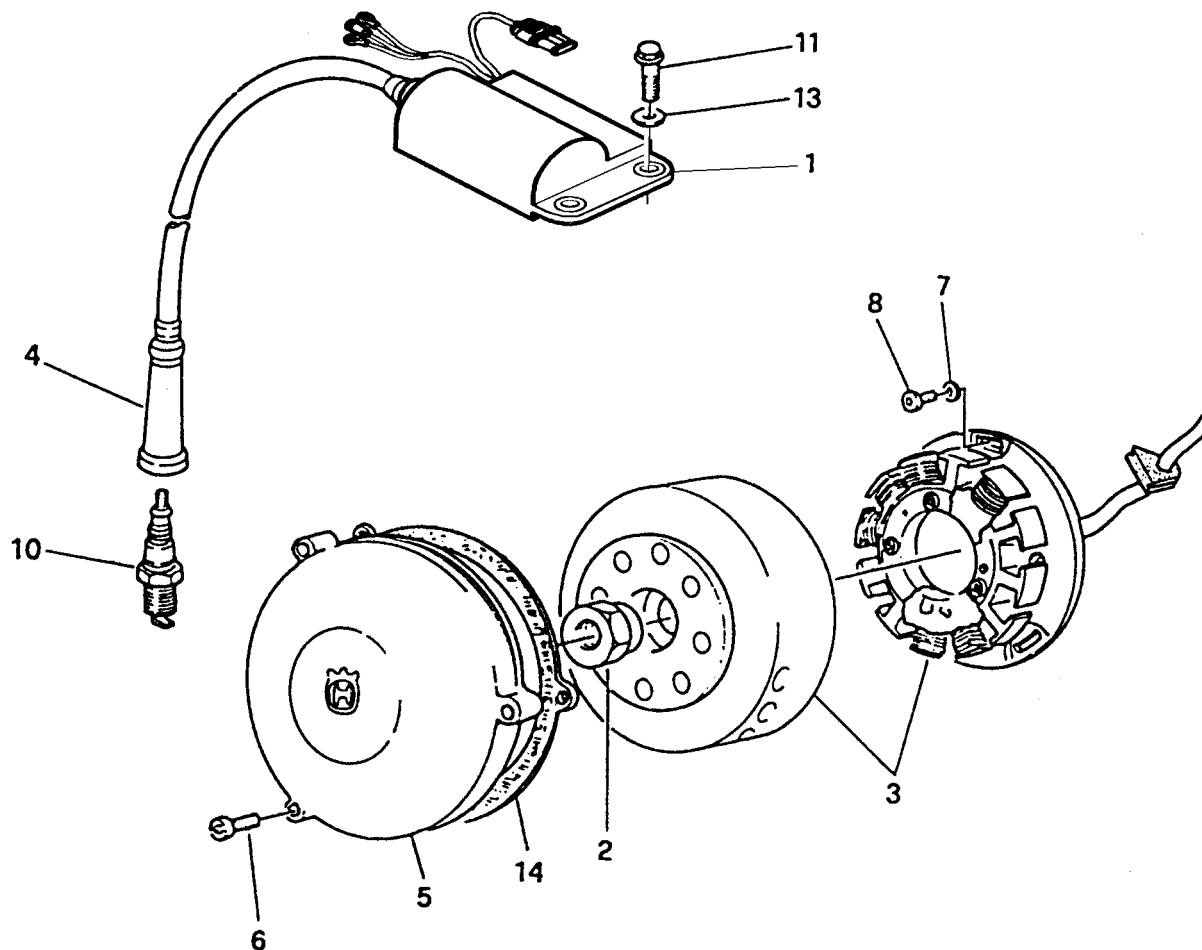



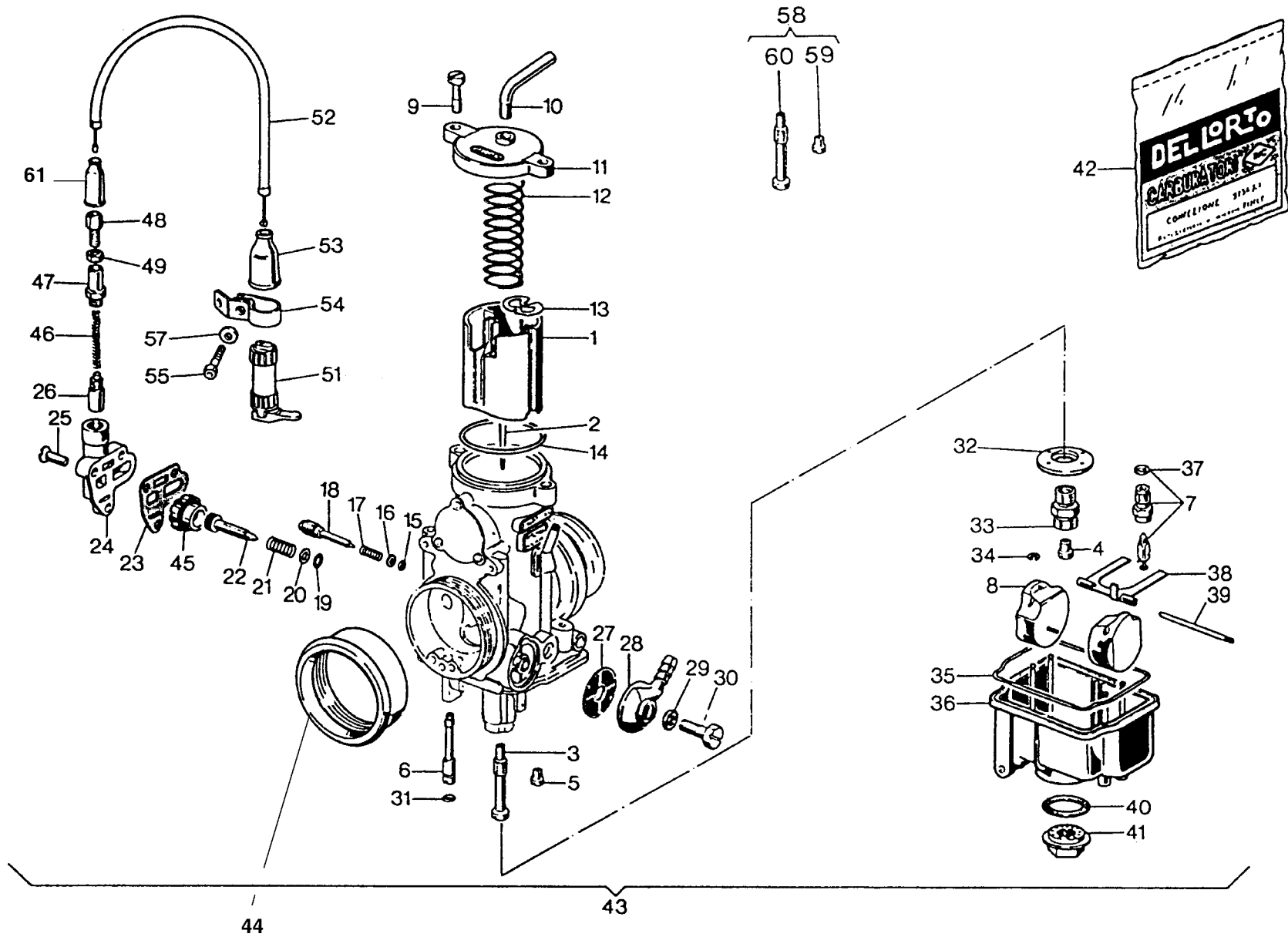

Note Notes Notes Marke Notas	Pos. No. Index	N. Cod. Code No. Nr. Code Code Nr N. Cod.	Q.tà Q.ty Q.te M.ge C.ad	DENOMINAZIONE	NAME	DESIGNATION	BESHREIBUNG	DENOMINACION	Validità Validity Validité Gültig Validez
	1	8000 60479	1	Valvola gas (50)	Throttle valve (50)	Papillon de gaz (50)	Drosselklappe (50)	Válvula (50)	
	2	8Q00 27910	1	Spillo conico (K32)	Needle (K32)	Pointeau conique (K32)	Kon. Nadel (K32)	Pasador cónico (K32)	
	3	8C00 24058	1	Polverizzatore (264 AB)	Fuel nozzle (264 AB)	Pulvérisateur (264 AB)	Einspritzdüse (264 AB)	Pulverizador (264 AB)	
	4	8AN0 12041	1	Getto massimo (175)	Main jet (175)	Gicleur principal (175)	Hauptdüse (175)	Chiclé máximo (175)	
D	4	8AI0 12041	1	Getto massimo (172)	Main jet (172)	Gicleur principal (172)	Hauptdüse (172)	Chiclé máximo (172)	
D	4	8AL0 12041	1	Getto massimo (178)	Main jet (178)	Gicleur principal (178)	Hauptdüse (178)	Chiclé máximo (178)	
D	4	8AP0 12041	1	Getto massimo (180)	Main jet (180)	Gicleur principal (180)	Hauptdüse (180)	Chiclé máximo (180)	
	5	8GA0 05761	1	Getto minimo da (62)	Idle jet (62)	Gicleur minimum (62)	Leerlaufdüse (62)	Chiclé mínimo (62)	
D	5	8PA0 05761	1	Getto minimo da (65)	Idle jet (65)	Gicleur minimum (65)	Leerlaufdüse (65)	Chiclé mínimo (65)	
	6	80A0 12032	1	Getto avviamento da (60)	Starting jet (60)	Gicleur de starter (60)	Starterdüse (60)	Chiclé arranque (60)	
	7	8000 33109	1	Valvola a spillo (300)	Needle valve (300)	Soupape à pointeau (300)	Nadelventil (300)	Válvula de aguja (300)	
	8	8000 90231	2	Galleggiante (g.4.0)	Float (g.4.0))	Flotteur (g.4.0)	Schwimmer (g.4.0)	Flotador (g.4.0)	
	9	8000 23981	2	Vite	Screw	Vis	Schraube	Tornillo	
	10	8000 67457	1	Tubetto	Tube	Tuyau	Rohr	Tubo	
	11	8000 60480	1	Coperchio	Cover	Couvercle	Deckel	Tapa	
	12	8000 40578	1	Molla	Spring	Ressort	Feder	Resorte	
	13	8000 23979	1	Fermaglio	Retainer	Arret	Klammer	Abrazadera de sujeción	
I	14		1	Guarnizione	Gasket	Garnitue	Dichtung	Junta	
I	15		1	Guarnizione	Gasket	Garnitue	Dichtung	Junta	
	16	8000 23985	1	Rosetta piana	Washer	Rondelle	Scheibe	Arandela	
	17	8000 12034	1	Molla	Spring	Ressort	Feder	Resorte	
	18	8000 12033	1	Vite regolazione minimo	Idling mixture adj. screw	Vis réglage mélange de ralenti	Regulierschraube	Tornillo regul. mezcla relenti	
I	19		1	Guarnizione	Gasket	Garnitue	Dichtung	Junta	
	20	8000 23983	1	Rosetta piana	Washer	Rondelle	Scheibe	Arandela	
	21	8000 12030	1	Molla	Spring	Ressort	Feder	Resorte	
	22	8000 12029	1	Vite registro valvola gas	Throttle adj. screw	Vis réglage papillons	Drosseleinstellschraube	Tornillo	
I	23		1	Guarnizione	Gasket	Garnitue	Dichtung	Junta	
	24	8000 28799	1	Corpo dispositivo avviamento	Starter body	Corps démarrage	Körper Anlass	Cuerpo puesta en marcha	
	25	8000 28798	3	Vite	Screw	Vis	Schraube	Tornillo	
	26	8000 40580	1	Dispositivo avviamento	Starting device	Dispositif de démarrage	Startvorrichtung	Dispositivo puesta en marcha	

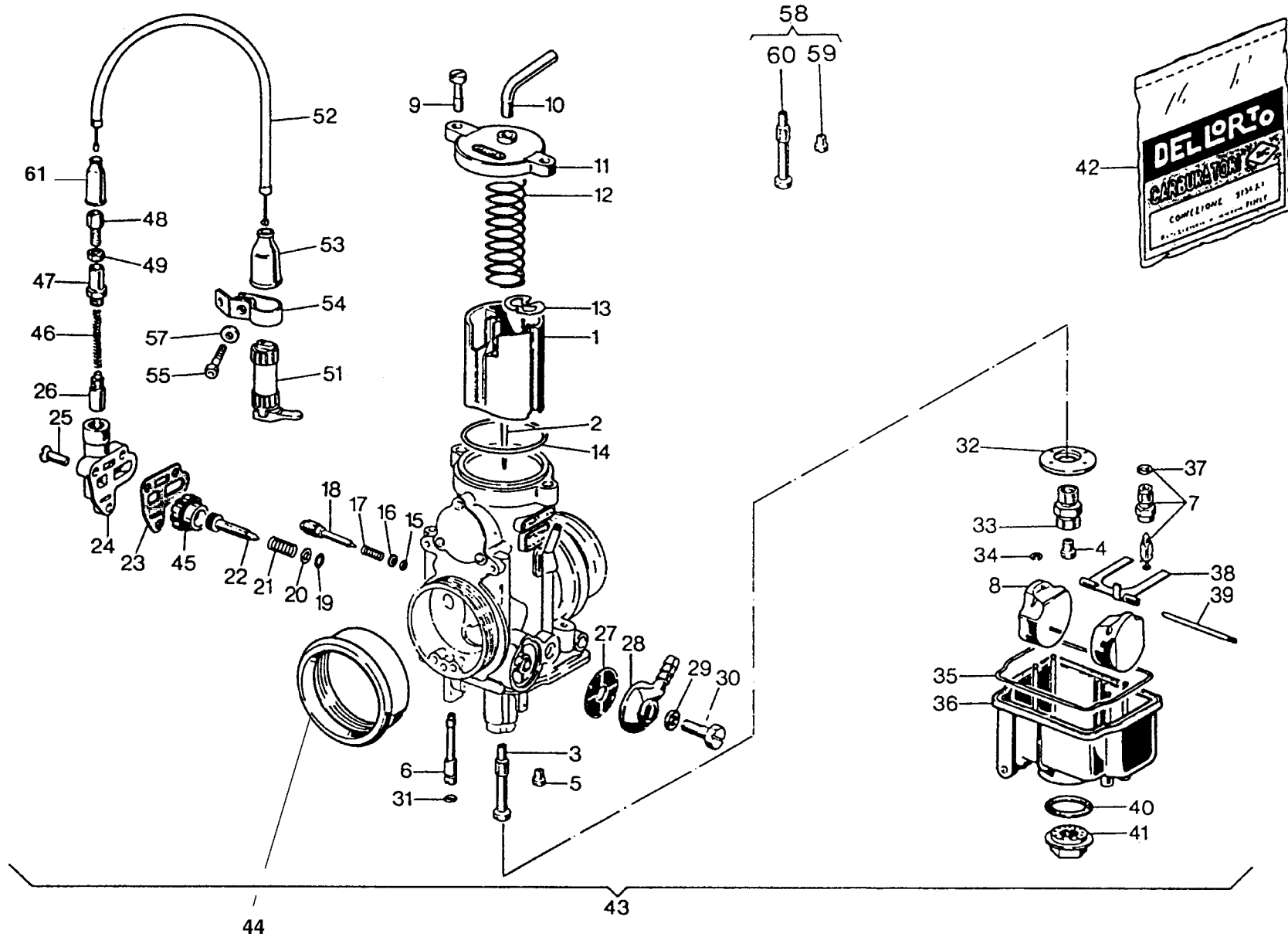

Note Notes Notes Marke Notas	Pos. No. N. Index Pos.	N. Cod. Code No. Nr. Code Code Nr N. Cod.	Q.tà Q.ty Q.te M.ge C.ad	DENOMINAZIONE	NAME	DESIGNATION	BESHREIBUNG	DENOMINACION	Validità Validity Validité Gültig Validez
	27	8000 12045	1	Filtro benzina	Fuel filter	Filtre essence	Benzinfilter	Filtro gasolina	
	28	8000 12046	1	Pipetta	Pipette	Pipette	Pipette	Pipa	
I	29		1	Guarnizione	Gasket	Garnitue	Dichtung	Junta	
	30	8000 12048	1	Vite	Screw	Vis	Schraube	Tornillo	
I	31		1	Guarnizione	Gasket	Garnitue	Dichtung	Junta	
	32	8000 32866	1	Fondello	Bottom	Fond	Bodenscheibe	Casquillo	
	33	8000 23990	1	Portagetto	Jet-holder	Porte-gicleur	Düsenträger	Porta-chiclé	
	34	8000 32865	2	Fermaglio	Retainer	Arret	Klammer	Abrazadera de sujeción	
I	35		1	Guarnizione	Gasket	Garnitue	Dichtung	Junta	
	36	8000 95269	1	Vaschetta	Chamber	Cuvette	Becken	Cubeta	
I	37		1	Guarnizione	Gasket	Garnitue	Dichtung	Junta	
	38	8000 60501	1	Bilanciere	Rocking lever	Balancier	Schwinge	Balancines	
	39	8000 32867	1	Perno	Pin	Pivot	Bolzen	Perno	
I	40		1	Guarnizione	Gasket	Garnitue	Dichtung	Junta	
	41	8000 33211	1	Tappo	Plug	Bouchon	Verschluss	Tapón	
	42	8000 60504	1	Busta guarnizioni	Gasket set	Jeu joints	Dichtungssatz	Serie juntas	
	43	8A00 67932	1	Carburatore completo	Carburetor assy	Carburateur complet	Vegaser, kpl.	Carburador compl.	
	44	1615 39001	1	Cornetto presa aria	Pipe	Manchon	Muffe	Tubo toma aire	
	45	8000 57413	1	Pomello	Knob	Poignée	Knopf	Pomo	
	46	8000 44043	1	Molla	Spring	Ressort	Feder	Resorte	
	47	8000 67458	1	Tappo	Plug	Bouchon	Verschluss	Tapón	
	48	8000 04103	1	Vite	Screw	Vis	Schraube	Tornillo	
	49	8000 04104	1	Dado	Nut	Ecrou	Mutter	Tuerca	
	51	8A00 40877	1	Leva comando starter	Lever	Levier	Hebel	Palanca	
	52	8000 67444	1	Trasmissione comando starter	Starter wire	Trasm. comm. starter	Anlassen Kabel	Transm. mando starter	
	53	8000 42980	1	Cappuccio	Cap	Capuchon	Kappe	Capuchón	
	54	8000 67434	1	Staffetta	Bracket	Etrier	Buegel	Brida	
	55	60N1 01048	1	Vite	Screw	Vis	Schraube	Tornillo	
	57	62N1 15503	1	Rosetta	Washer	Rondelle	Scheibe	Arandela	
R	58	8000 72092	1	Kit omologazione ECE	ECE homologation kit	Gr. homolog. ECE	Ratifikation ECE Gruppe	Kit homologación ECE	

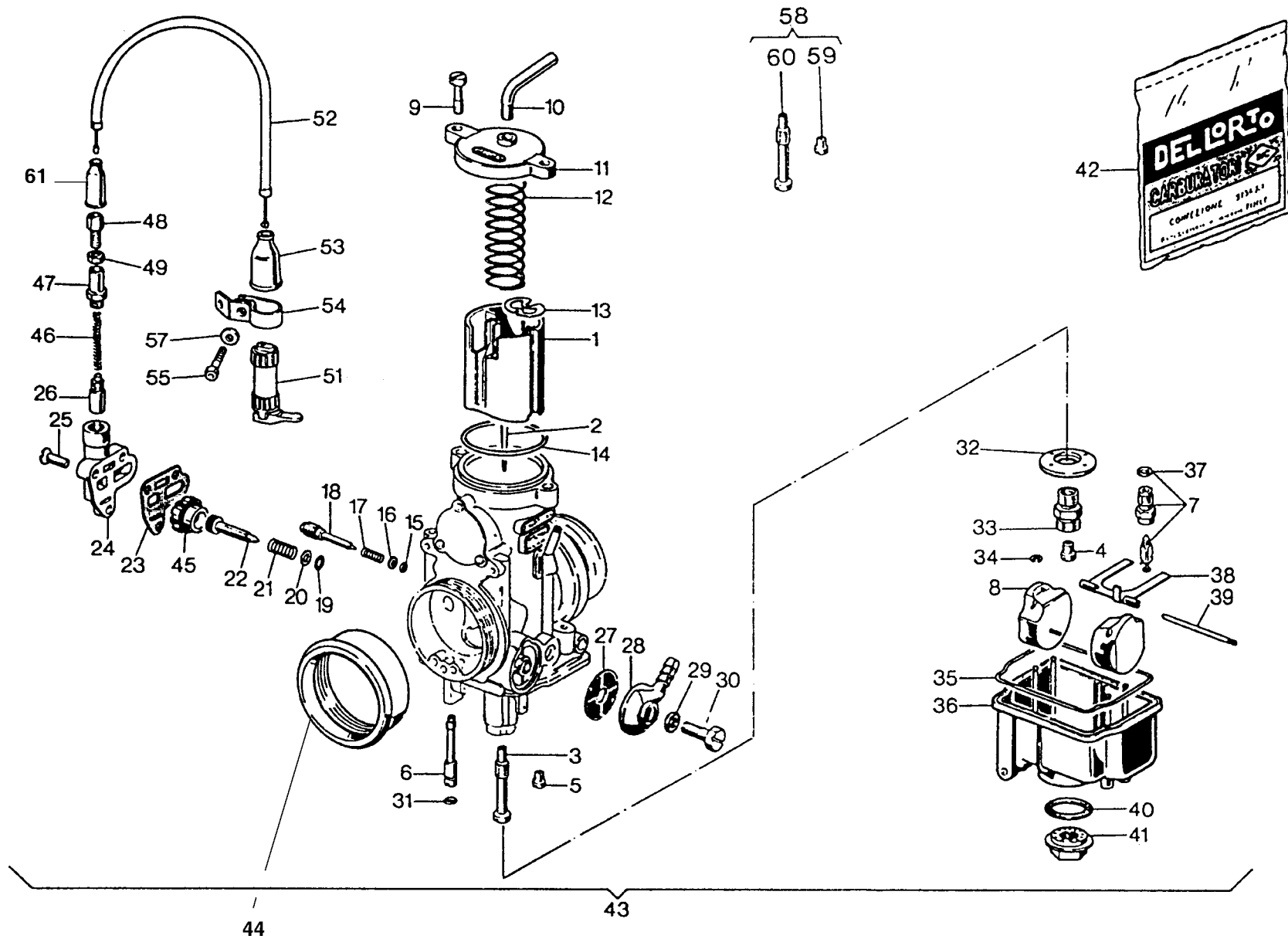





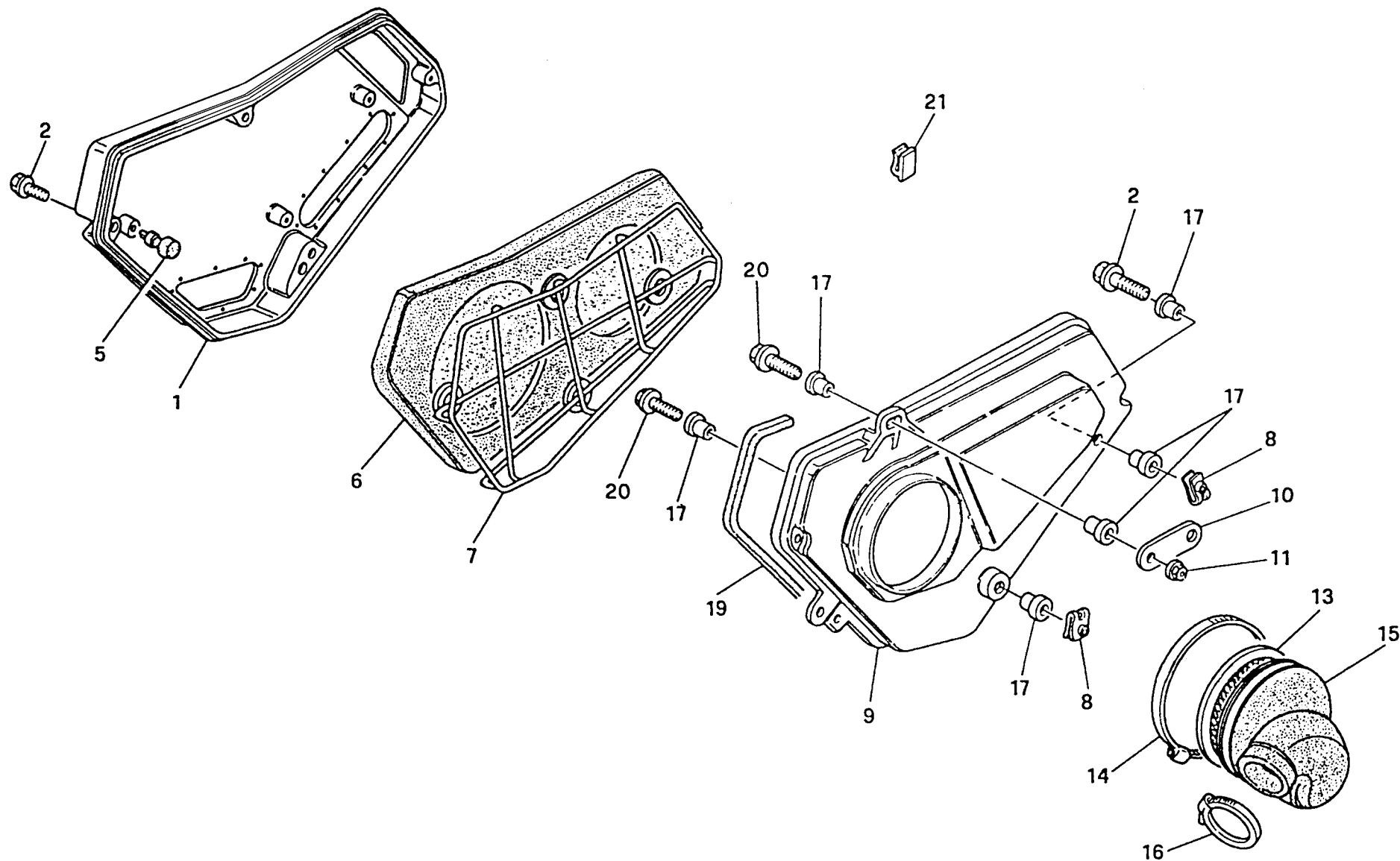



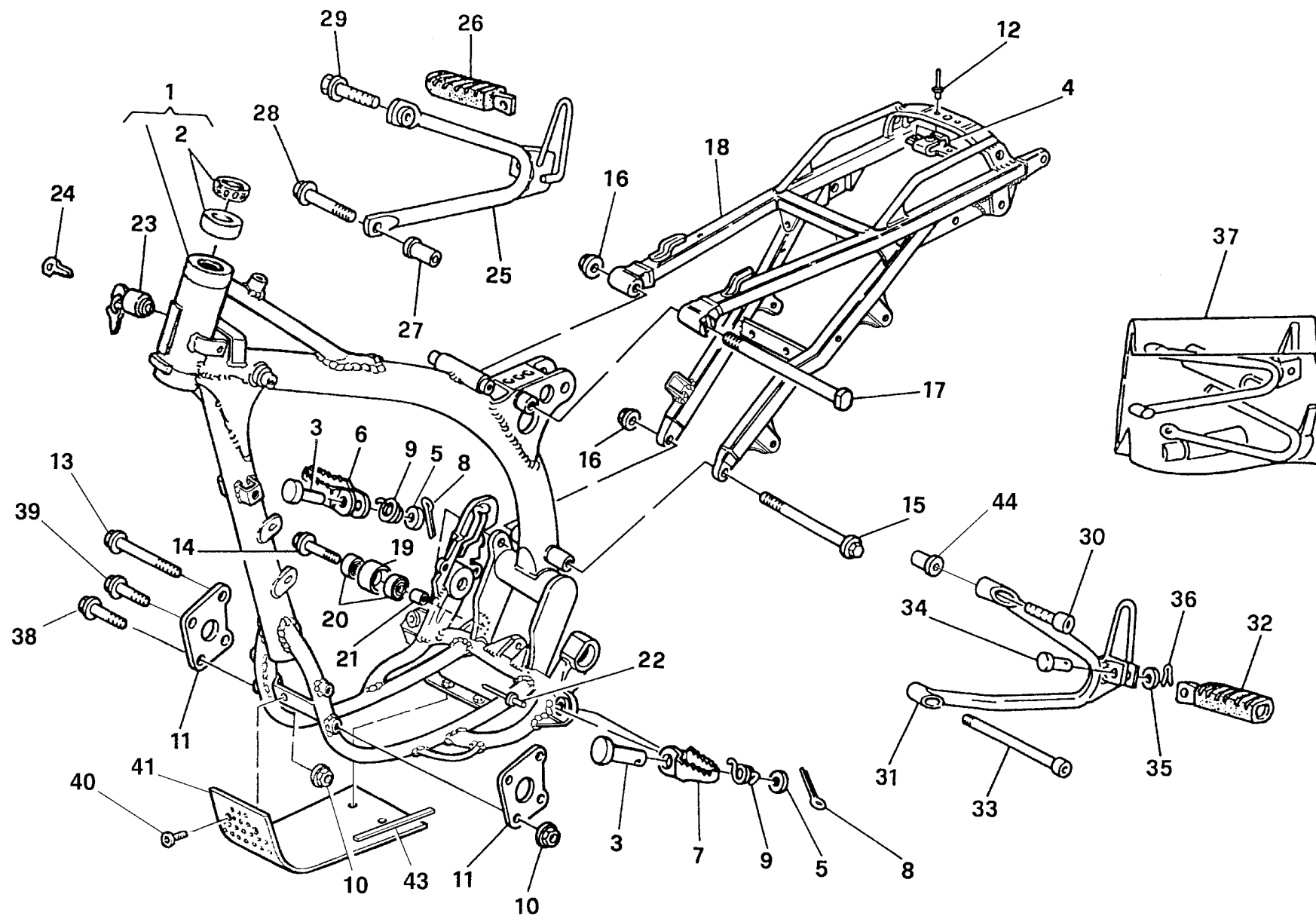

Note Notes Notes Marke Notas	Pos. No. Index	N. Cod. Code No. Nr. Code Code Nr N. Cod.	Q.tà Q.ty Q.te M.ge C.ad	DENOMINAZIONE	NAME	DESIGNATION	BESHREIBUNG	DENOMINACION	Validità Validity Validité Gültig Validez
	1	8A00 92957	1	Telaio	Frame	Chassis	Rahmen	Bastidor	
	2	1513 07001	2	Cuscinetto	Bearing	Roulement	Lager	Cojinete	
	3	8000 73140	2	Perno	Pin	Pivot	Bolzen	Perno	
	4	8000 69150	1	Piastrina	Plate	Plaquette	Plättchen	Placa	
	5	8A00 01815	2	Rosetta	Washer	Rondelle	Scheibe	Arandela	
	6	80A0 89953	1	Poggiapiedi Dx.	R.H. foot rest support	Support repose pied D.	R., Fussraster	Prisioneros derech. compl.	
	7	80A0 89962	1	Poggiapiedi Sx.	L.H. foot rest support	Support repose pied G.	L., Fussraster	Prisioneros compl.	
	8	64N1 20068	2	Copiglia	Split pin	Goupille	Splint	Clavija	
	9	8000 89882	1	Molla Dx	R.H. spring	Ressort D.	Feder Rechte	Resorte der.	
	10	80B0 43928	6	Dado	Nut	Ecrou	Mutter	Tuerca	
	11	8000 84665	2	Piastra motore	Motor plate	Plaquette moteur	Motorplättchen	Placa motor	
	12	8000 33373	2	Rivetto	Rivet	Rivet	Niet	Remache	
	13	8000 80277	2	Vite (M8x95 mm)	Screw (M8x95 mm)	Vis (M8x95 mm)	Schraube (M8x95 mm)	Tornillo(M8x95 mm)	
	14	8000 62796	2	Vite (M8x40 mm)	Screw (M8x40 mm)	Vis (M8x40 mm)	Schraube (M8x40 mm)	Tornillo (M8x40 mm)	
	15	8C00 69112	1	Vite	Screw	Vis	Schraube	Tornillo	
	16	8000 43928	2	Dado	Nut	Ecrou	Mutter	Tuerca	
	17	8000 69111	1	Vite (M8x130 mm)	Screw (M8x130 mm)	Vis (M8x130 mm)	Schraube (M8x130 mm)	Tornillo (M8x130 mm)	
	18	8000 92931	1	Telaio posteriore	Rear frame side	Chassis arrière	Sattelbrücke	Cuadro posterior	
	19	8000 59433	2	Rullo	Roller	Aiguille	Rolle	Rodillo	
	20	8000 63312	4	Cuscinetto	Bearing	Roulement	Lager	Cojinete	
	21	8000 59434	2	Distanziale	Spacer	Entretoise	Distanzstück	Separador	
	22	8000 41922	2	Rivetto	Rivet	Rivet	Niet	Remache	
	23	8000 43391	1	Serratura antifurto	Anti-left lock assy	Serrure anti-vol compl.	Sicherheitsschloss kpl.	Cerradura compl.	
	24	8000 35531	1	Chiave grezza	Raw key	Clef primitive	Schlüssel	Llave	
D	25	8000 94354	1	Supp. poggiapiedi Passegg. Dx.	Support	Support	Halterung	Soporte elástico	
D	26	8000 66652	1	Poggiapiedi passeggero Dx.	R.H. foot rest support	Support repose pied D.	R., Fussraster	Prisioneros derech. compl.	
D	27	8000 67724	1	Distanziale	Spacer	Entretoise	Distanzstück	Separador	
D	28	8A00 62797	1	Vite	Screw	Vis	Schraube	Tornillo	
D	29	8000 69056	2	Vite	Screw	Vis	Schraube	Tornillo	
D	30	8000 69056	1	Vite	Screw	Vis	Schraube	Tornillo	
D	31	8000 94322	1	Supp. poggiapiedi passegg. Sx.	Support	Support	Halterung	Soporte elástico	
D	32	8000 66651	1	Poggiapiedi passeggero Sx.	L.H. foot rest support	Support repose pied G.	L., Fussraster	Prisioneros compl.	

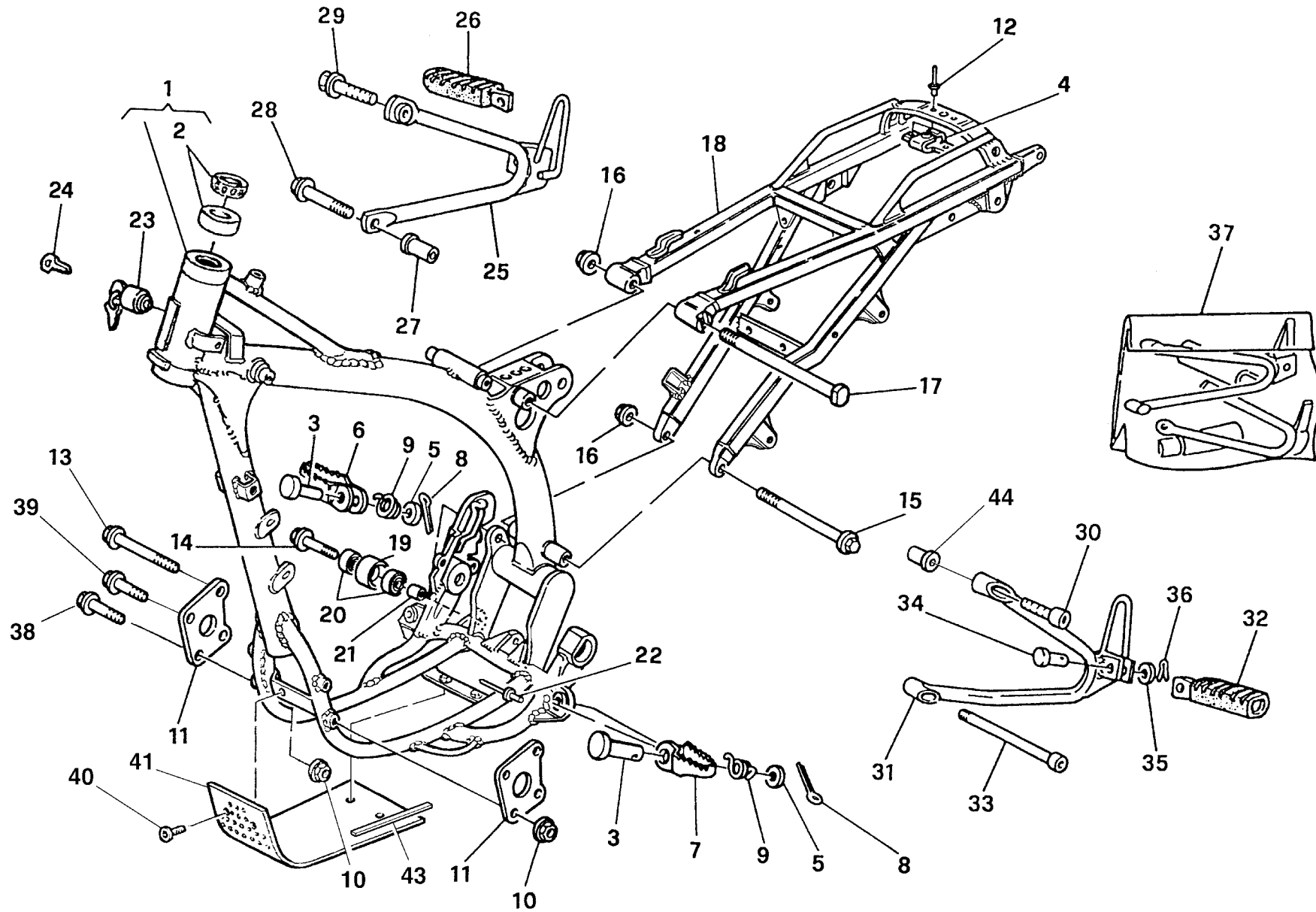







Note Notes Notas	Pos. No. Index	N. Cod. Code No. Nr. Code Code Nr N. Cod.	Q.tà Q.ty Q.te M.ge C.ad	DENOMINAZIONE	NAME	DESIGNATION	BESCHREIBUNG	DENOMINACION	Validità Validity Validité Gültig Validez
	1	8000 95703	1	Testa di sterzo	Steering head	Tête direction	Lenkkopf	Cabezal de dirección	
	2	8000 62796	8	Vite	Screw	Vis	Schraube	Tornillo	
	3	8000 83395	1	Ghiera registro cuscinetti	Ring nut	Embout	Nutmutter	Vírol	
	4	8000 95702	1	Base di sterzo con perno	Steering crown with pin	Socle de direction avec pivot	Gabelbrücke mit Bolzen	Base de dirección con perno	
	5	8000 96643	1	Stelo Sx. compl.	L.H. slider assy	Montant G. compl.	Bein, Kpl. L.	Deslizable izrda. compl.	
	6	8000 91506	1	Stelo Dx. compl.	R.H. slider assy	Montant D. compl.	Bein, Kpl. R.	Deslizable der. compl.	
	7	8000 91473	2	Portastelo	Pipe	Tuyau	Rohr	Tubo	
**	8	8000 70328	2	Bussola	Bushing	Douille	Buchse	Manguito	
	9	8000 86385	2	Scodellino	Cup	Cuvette	Teller	Cubeta	
***	10	8000 85930	2	Anello di tenuta	Seal ring	Bague de retenue	Dichtring	Anillo de retención	
	11	8000 81161	2	Anello di fermo	Stop ring	Bague d'arrêt	Haltering	Anillo de retención	
***	12	8000 81162	2	Raschiapolvere	Dust scraper	Racloir poudre	Pulverabschaber	Rascador de polvo	
	13	8000 91474	2	Portastelo completo	Pipe assy	Groupe tuyau compl.	Rohrgruppe Kpl	Grupo tubo compl.	
	14	8000 84702	2	Vite	Screw	Vis	Schraube	Tornillo	
	15	8000 91475	2	Sfera	Ball	Bille	Kugel	Esfera	
	16	8000 91476	2	Molla per sfera	Spring	Ressort	Feder	Resorte	
	17	8000 91477	2	Grano filettato	Dowel	Grain	Stift	Pasadør	
*	18	8000 91478	2	Anello OR	O-Ring	Bague OR	O-Ring	Anillo OR	
	19	8000 91479	2	Gruppo registro	Adjuster set	Groupe reglage	Reglergruppe	Grupo regulaciòn	
	20	8000 77373	2	Scodellino	Cup	Cuvette	Teller	Cubeta	
	21	8000 95331	2	Molla( k= 5,0 N/mm)	Spring ( k= 5,0 N/mm)	Ressort( k= 5,0 N/mm)	Feder ( k= 5,0 N/mm)	Resorte ( k= 5,0 N/mm)	
	22	8000 96645	2	Pompante completo	Damping element compl.	Amortissement compl.	Schwingungsdämpfer Kpl.	Bombeadora compl.	
	25	8000 96646	2	Tubetto	Pipe	Tuyau	Rohr	Tubo	
**	39	8000 91497	2	Bussola	Bushing	Douille	Buchse	Manguito	
	40	8000 62729	4	Vite	Screw	Vis	Schraube	Tornillo	
	41	8000 96647	2	Ass. valvola di fondo	Valve	Soupape	Ventil	Válvula	
	48	8000 91480	2	Gruppo tappo	Plug assy	Groupe bouchon	Verschlussgruppe Kpl	Grupo tapòn	
	49	8000 95699	1	Gamba Sx. compl.	L.H. fork leg assy	Fourche compl. G.	Telegabel, Kpl. L.	Horquilla izrda. compl.	
	50	8000 95698	1	Gamba Dx. compl.	R.H. fork leg assy	Fourche complete D.	Telegabel Kpl. R.	Horquilla derech. compl.	
	51	80C0 69981	1	Piastrina	Plate	Plaquette	Plättchen	Placa	
	52	8A00 67997	2	Vite	Screw	Vis	Schraube	Tornillo	
	53	8000 61355	2	Dado	Nut	Ecrou	Mutter	Tueca	



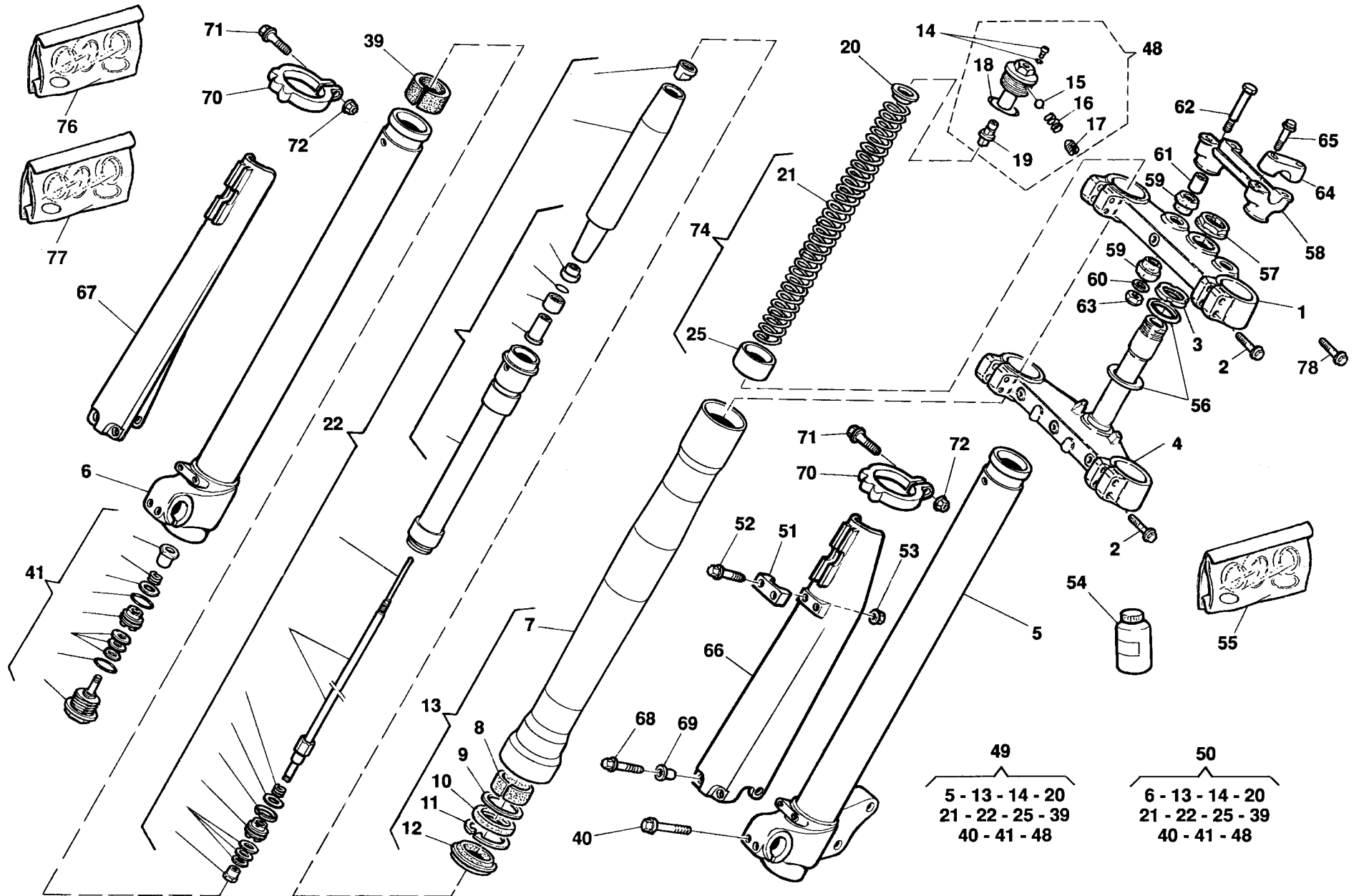

49  
5 - 13 - 14 - 20  
21 - 22 - 25 - 39  
40 - 41 - 48

50  
6 - 13 - 14 - 20  
21 - 22 - 25 - 39  
40 - 41 - 48

Note Notes Notes Mark Notas	Pos. No. Index Pos.	N. Cod. Code No. Nr. Code Code Nr N. Cod.	Q.tà Q.ty Q.te M.ge C.ad	DENOMINAZIONE	NAME	DESIGNATION	BESHREIBUNG	DENOMINACION	Validità Validity Validité Gültig Validez
R	54	8000 80260	1	Olio forcella	Front fork oil	Huile fourche avant	Öl für die Vordergabel	Aceite horquilladelantera	
	55	8000 91519	1	Gruppo guarnizioni	Gasket set	Groupe garnitures	Dichtungssatz	Grupo juntas	
	56	8A00 65503	2	Rosetta piana	Washer	Rondelle	Scheibe	Arandela	
	57	8000 69315	1	Dado	Nut	Ecrou	Mutter	Tuerca	
	58	8000 73141	1	Morsetto inferiore	Hub	Moyeau	Radnabe	Cbo	
	59	8000 60233	4	Gommino	Rubber pad	Pièce caoutchouc	Gummistück	Junta de goma	
	60	8000 60234	2	Rosetta piana	Washer	Rondelle	Scheibe	Arandela	
	61	8000 53155	2	Distanziale	Spacer	Entretoise	Distanzstück	Separador	
	62	60N1 01219	2	Vite (M10x65 mm)	Screw (M10x65 mm)	Vis (M10x65 mm)	Schraube (M10x65 mm)	Tornillo (M10x65 mm)	
	63	8000 61314	2	Dado	Nut	Ecrou	Mutter	Tuerca	
	64	8000 68516	2	Morsetto superiore	Hub	Moyeau	Radnabe	Cubo	
	65	8000 62733	4	Vite (M8x35 mm)	Screw (M8x35 mm)	Vis (M8x35 mm)	Schraube (M8x35 mm)	Tornillo (M8x35 mm)	
	66	8000 95696	1	Protezione steli Sx.	Guard L.H.	Protection D.	Schutz L.	Protección izq.	
	67	80C0 69338	1	Protezione steli Dx.	Guard R.H.	Protection G.	Schutz R.	Protección der.	
	68	8000 67997	6	Vite	Screw	Vis	Schraube	Tornillo	
	69	8000 69282	6	Bussola	Bush	Douille	Buchse	Manguito	
	70	80A0 70558	2	Anello	Ring	Bague	Ring	Anilo	
	71	8B00 66525	2	Vite	Screw	Vis	Schraube	Tornillo	
	72	8000 56443	2	Dado	Nut	Ecrou	Mutter	Tuerca	
R	74	8000 91608	1	Kit molla( k=4,0 N/mm)	Spring ( k=4,0 N/mm)	Ressort ( k=4,0 N/mm)	Feder ( k=4,0 N/mm)	Resorte ( k=4,0 N/mm)	
R	74	8000 91609	1	Kit molla(k=4,2 N/mm)	Spring (k=4,2 N/mm)	Ressort (k=4,2 N/mm)	Feder(k=4,2 N/mm)	Resorte (k=4,2 N/mm)	
R	74	8000 91607	1	Kit molla( k=3,8 N/mm)	Spring ( k=3,8 N/mm)	Ressort ( k=3,8 N/mm)	Feder ( k=3,8 N/mm)	Resorte ( k=3,8 N/mm)	
R	74	8000 91610	1	Kit molla (k=4,5 N/mm)	Spring (k=4,5 N/mm)	Ressort (k=4,5 N/mm)	Feder (k=4,5 N/mm)	Resorte (k=4,5 N/mm)	
R	74	8000 91611	1	Kit molla (k=4,8 N/mm)	Spring (k=4,8 N/mm)	Ressort (k=4,8 N/mm)	Feder (k=4,8 N/mm)	Resorte (k=4,8 N/mm)	
R	74	8000 95263	1	Kit molla (k=5,0 N/mm)	Spring (k=5,0 N/mm)	Ressort (k=5,0 N/mm)	Feder (k=5,0 N/mm)	Resorte (k=5,0 N/mm)	
	76	8000 97750	1	Kit boccole	Bushes kit	Kit douilles	Buchse kit	Kit manguitos	
	77	8000 97749	1	Kit anelli di tenuta	Sealskit	Kit bagues de retanue	Dichtring kit	Kit anillos de retención	
	78	8000 62723	1	Vite (M8x35 mm)	Screw (M8x35 mm)	Vis (M8x35 mm)	Schraube (M8x35 mm)	Tornillo (M8x35 mm)	
*				Forniti anche in gruppo pos. 55	Supplied in bag ref. N° 55	Son fournies en unités pos. 55	Sind im Umschlag Bez. Nr 55	Provisto en grupo pos. 55	
**				Forniti anche in gruppo pos. 76	Supplied in bag ref. N° 76	Son fournies en unités pos. 76	Sind im Umschlag Bez. Nr 76	Provisto en grupo pos. 76	
***				Forniti anche in gruppo pos. 77	Supplied in bag ref. N° 77	Son fournies en unités pos. 77	Sind im Umschlag Bez. Nr 77	Provisto en grupo pos. 77	

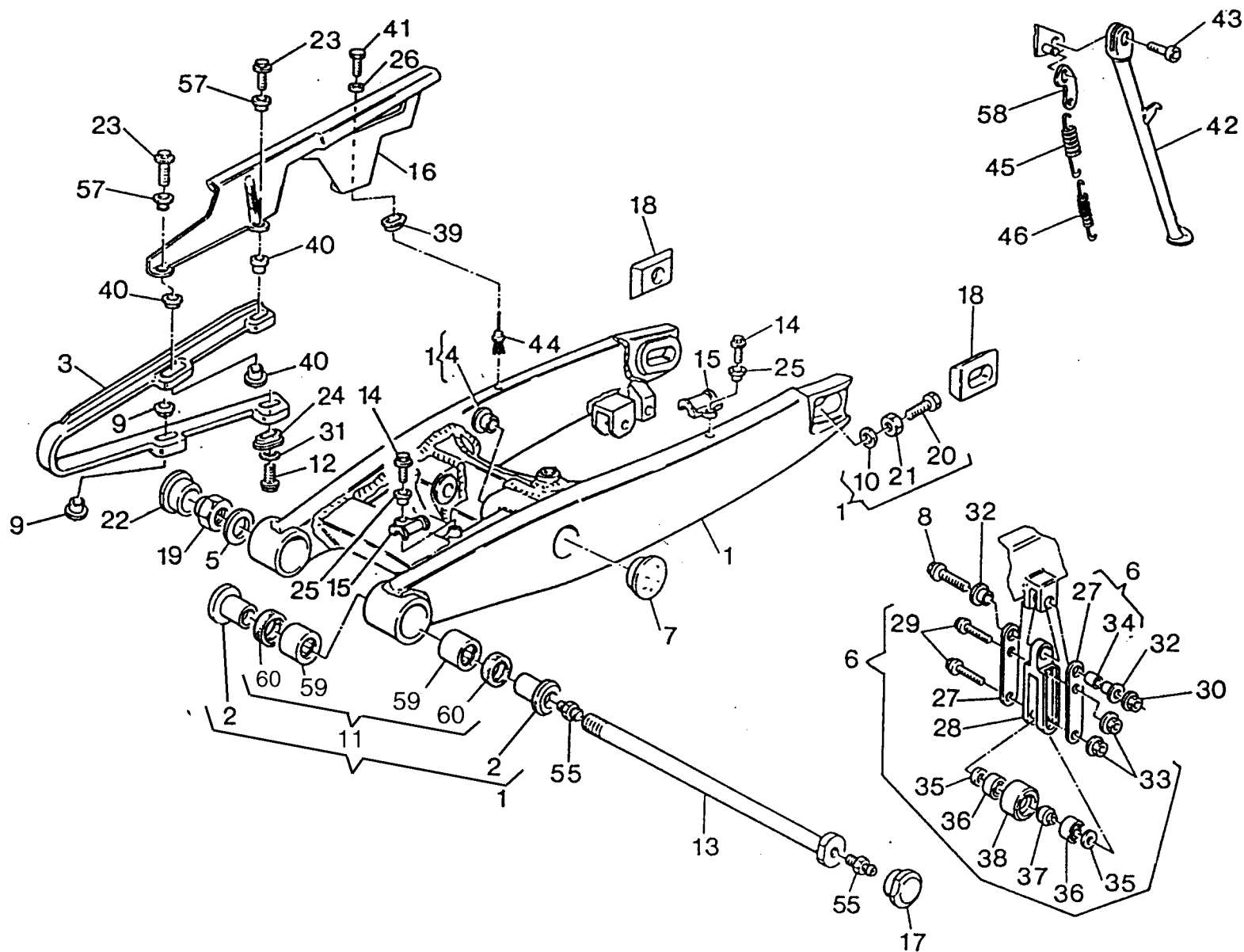

Note Notes Notas	Pos. No. Index	N. Cod. Code No. Nr. Code Code Nr N. Cod.	Q.tà Q.ty Q.te M.ge C.ad	DENOMINAZIONE	NAME	DESIGNATION	BESHREIBUNG	DENOMINACION	Validità Validity Validité Gültig Validez
	1	8000 93126	1	Forcellone completo	Compl. fork	Fourche complete	Gabel, Kpl.	Horquilla compl.	
	2	8000 66196	4	Bussola	Bushing	Douille	Buchse	Manguito	
	3	8000 72884	1	Pattino catena	Chain slider	Glissière	Gleitbahn	Plato cadena	
	4	8B00 42029	4	Bussola	Bushing	Douille	Buchse	Manguito	
	5	62N1 15524	1	Rosetta piana	Washer	Rondelle	Scheibe	Arandela	
	6	8000 72873	1	Guidacatena	Chain guide	Guide-chaîne	Kettenführung	Guía-cadena	
	7	80A0 74388	2	Tappo	Plug	Bouchon	Verschluss	Tapón	
	8	8000 62795	1	Vite	Screw	Vis	Schraube	Tornillo	
	9	8000 75166	2	Scodellino	Cup	Cuvette	Teller	Cubeta	
	10	8000 08536	2	Rosetta	Washer	Rondelle	Scheibe	Arandela	
	11	8000 67373	1	Kit cuscinetti e anelli di tenuta	Bearing and seal ring kit	Gr. roulemen.et bague de reten.	Kugellager und Dichtring gruppe	Kit cojinete y anillo de retencion	
	12	8000 67997	2	Vite	Screw	Vis	Schraube	Tornillo	
	13	8000 64591	1	Perno forcellone	Fork pin	Pivot fourche	Gabelbolzen	Perno horquilla	
	14	8000 20536	2	Vite	Screw	Vis	Schraube	Tornillo	
	15	80A0 73456	2	Guidacavo	Cable guide	Guide câble	Kabelführung	Guía-cable	
	16	8AA 73426	1	Copricatena	Chain guard	Carter de chaîne	Kettenkasten	Cubre-cadena	
	17	80A0 66202	1	Tappo	Plug	Bouchon	Verschluss	Tapón	
	18	8000 71624	1	Tendicatena lato dado	Chain adjuster - nut side	Tendeur de chaîne côtés écrou	Kettenspanner Mutterseite	Tensor de cadena lato tuerca	
	18	8000 71625	1	Tendicatena lato perno	Chain adjuster - pin side	Tendeur de chaîne côtés pivot	Kettenspanner bolzenseite	Tensor de cadena lato perno	
	19	1511 24901	1	Dado	Nut	Ecrou	Mutter	Tuerca	
	20	8C00 61121	2	Vite	Screw	Vis	Schraube	Tornillo	
	21	8000 17810	2	Dado	Nut	Ecrou	Mutter	Tuerca	
	22	80A0 74388	1	Tappo	Plug	Bouchon	Verschluss	Tapón	
	23	8C00 67997	2	Vite	Screw	Vis	Schraube	Tornillo	
	24	8000 59289	1	Scodellino	Cup	Cuvette	Teller	Cubeta	
	25	8000 69282	2	Bussola	Bushing	Douille	Buchse	Manguito	
	26	8000 36137	1	Rosetta	Washer	Rondelle	Scheibe	Arandela	
	27	8000 72875	2	Lamiera guidacatena	Chain guide	Guide-chaîne	Kettenführung	Guía-cadena	
	28	8000 72874	1	Piastra d'attacco	Plate	Plaque	Platte	Placa	
	29	8000 62731	2	Vite	Screw	Vis	Schraube	Tornillo	
	30	8000 43928	1	Dado	Nut	Ecrou	Mutter	Tuerca	

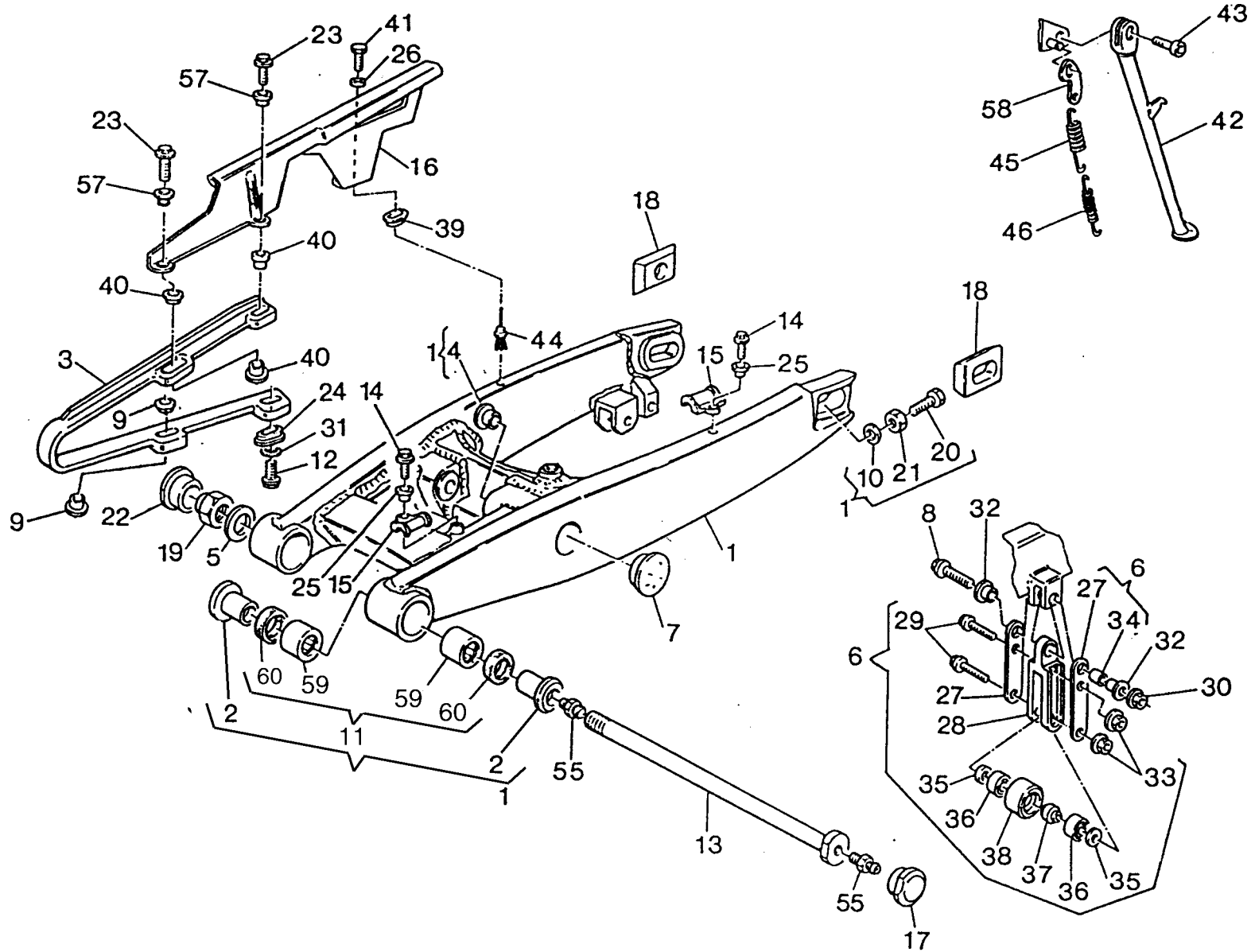

Note Notes Notes Marke Notas	Pos. No. N. Index Pos.	N. Cod. Code No. Nr. Code Code Nr N. Cod.	Q.tà Q.ty Q.te M.ge C.ad	DENOMINAZIONE	NAME	DESIGNATION	BESHREIBUNG	DENOMINACION	Validità Validity Validité Gültig Validez
	31	8000 36137	2	Rosetta	Washer	Rondelle	Scheibe	Arandela	
	32	8A00 66661	1	Bussola	Bushing	Douille	Buchse	Manguito	
	33	8000 44240	2	Dado	Nut	Ecrou	Mutter	Tuerca	
	34	1515 50601	1	Bussola elastica	Bushing	Douille	Buchse	Manguito	
	35	8000 45495	2	Rosetta di spallamento	Washer	Rondelle	Scheibe	Arandela	
	36	8000 63312	2	Cuscinetto (ø8xØ22x7 mm)	Bearing (ø8xØ22x7 mm)	Roulement (ø8xØ22x7 mm)	Kugellager (ø8xØ22x7 mm)	Cojinete (ø8xØ22x7 mm)	
	37	8000 65412	1	Distanziale	Spacer	Entretoise	Distanzstück	Separador	
	38	8000 65411	1	Rullo guidacatena	Roller	Aiguille	Rolle	Rodillo	
	39	8000 59289	1	Scodellino	Cup	Cuvette	Teller	Cubeta	
	40	8000 75166	3	Scodellino	Cup	Cuvette	Teller	Cubeta	
	41	8000 20536	1	Vite	Screw	Vis	Schraube	Tornillo	
	42	8A00 93066	1	Gamba laterale	Side stand	Bequille lat.	Seitenständer	Horquilla lateral	
	43	8000 93064	1	Vite	Screw	Vis	Schraube	Tornillo	
	45	8000 94488	1	Molla esterna	Spring	Ressort	Feder	Resorte	
	46	8000 94489	1	Molla interna	Spring	Ressort	Feder	Resorte	
	55	8000 01412	2	Ingrassatore	Lubricator	Graisneur	Schmierbüchse	Lubricador	
	57	8A00 69282	2	Distanziale	Spacer	Entretoise	Distanzstück	Separador	
	58	8A00 62644	1	Piastrina	Plate	Plaquette	Plättchen	Placa	
	59	8000 67371	4	Gabbia a rulli (ø22xØ28x12 mm)	Needle cage (ø22xØ28x12 mm)	Cage à aiguilles (ø22xØ28x12 mm)	Nadelkäfig (ø22xØ28x12 mm)	Jaula de agujas del cojinete (ø22xØ28x12 mm)	
	60	8000 67372	4	Anello (ø22xØ28x4 mm)	Ring (ø22xØ28x4 mm)	Bague (ø22xØ28x4 mm)	Ring (ø22xØ28x4 mm)	Anillo (ø22xØ28x4 mm)	

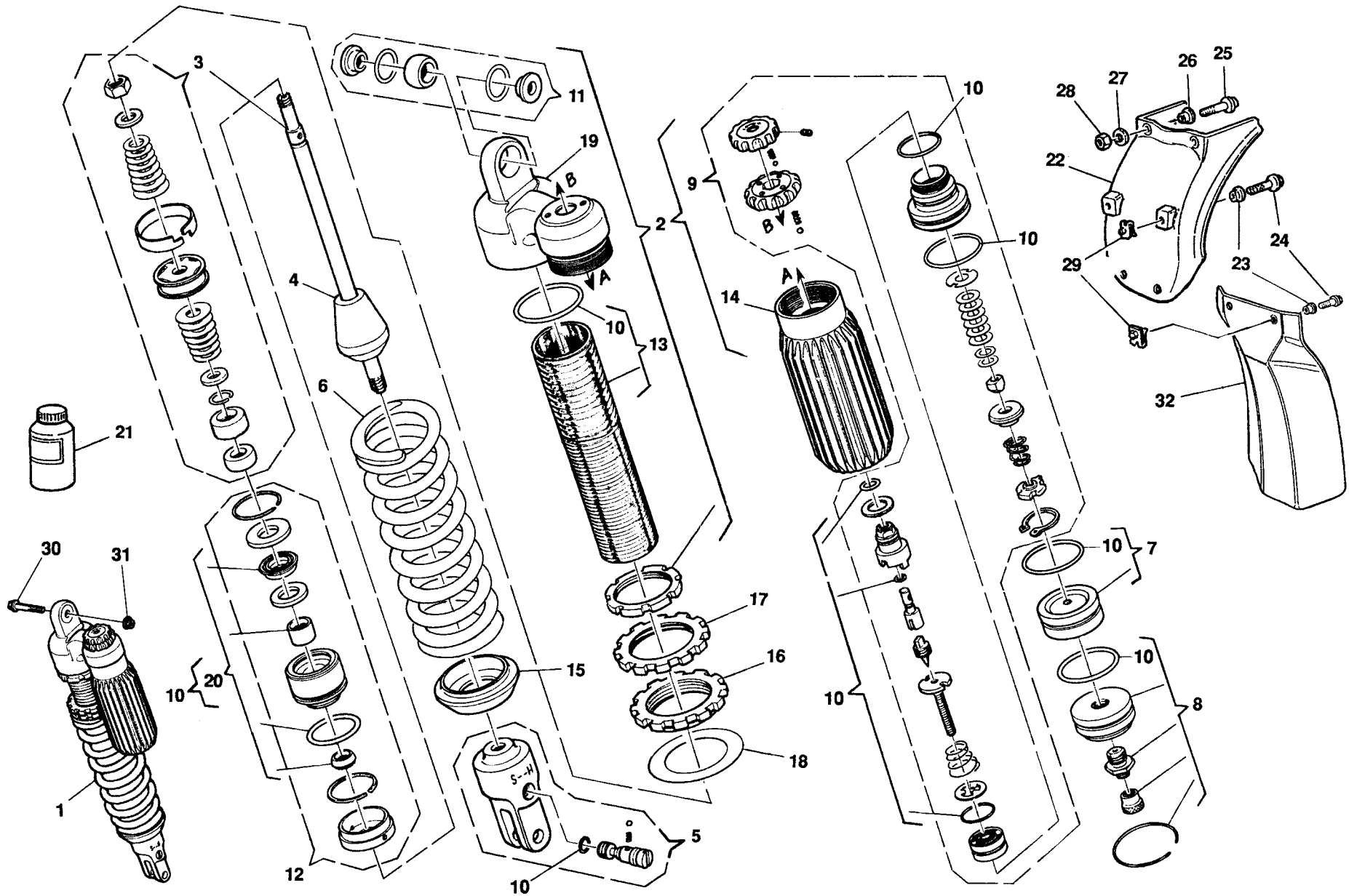







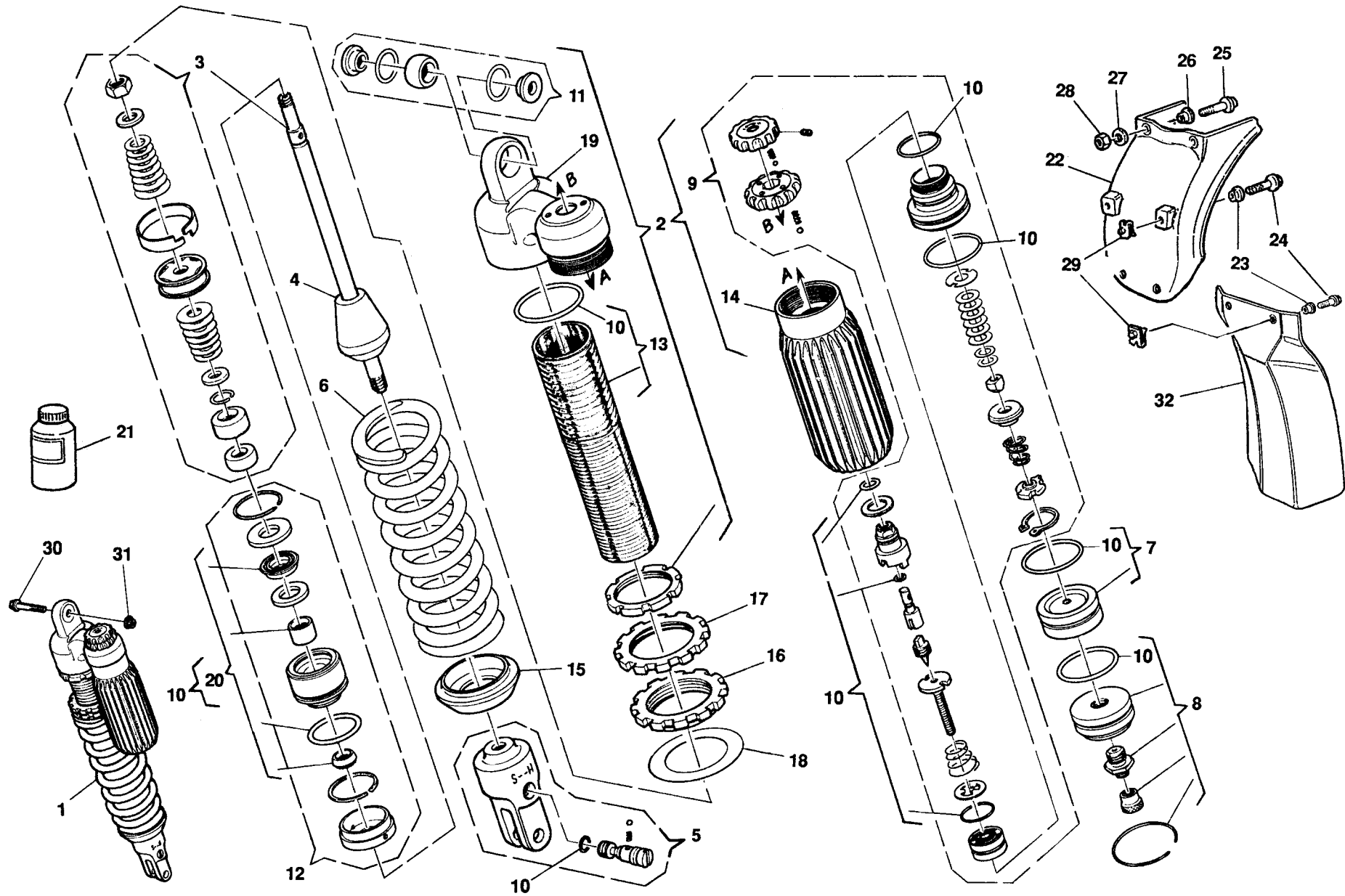



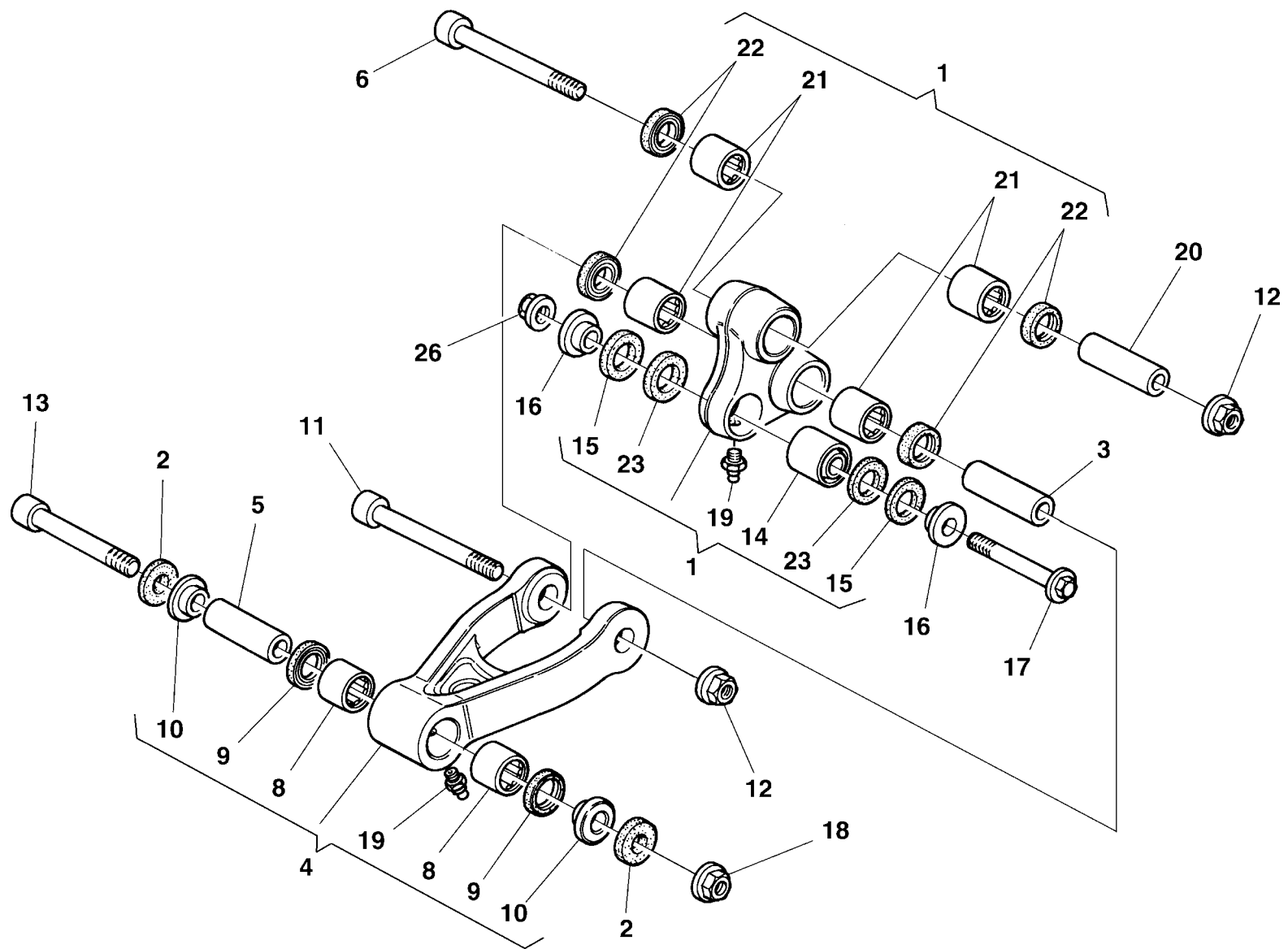

Note Notes Notes Marke Notas	Pos. No. N. Index Pos.	N. Cod. Code No. Nr. Code Code Nr N. Cod.	Q.tà Q.ty Q.te M.ge C.ad	DENOMINAZIONE	NAME	DESIGNATION	BESHREIBUNG	DENOMINACION	Validità Validity Validité Gültig Validez
	1	8000 90563	1	Tirante verticale	Tie rod	Tirant	Spannstange	Tirante	
	2	8000 73394	4	Anello di feltro	Feltseal	Bague en fetre	Filzring	Anillo de fieltro	
	3	8A00 75153	1	Spinotto	Gudgeon	Axe	Bolzen	Perno	
	4	8C00 69285	1	Tirante orizzontale	Tie rod	Tirant	Spannstange	Tirante	
	5	8000 59839	1	Spinotto	Gudgeon	Axe	Bolzen	Perno	
	6	8E00 74372	1	Vite	Screw	Vis	Schraube	Tornillo	
	8	8000 38956	2	Cuscinetto	Bearing	Roulement	Lager	Cojinete	
				(ø18xØ24x16 mm)	(ø18xØ24x16 mm)	(ø18xØ24x16 mm)	(ø18xØ24x16 mm)	(ø18xØ24x16 mm)	
	9	8000 38957	2	Guarnizione	Gasket	Garnitue	Dichtung	Junta	
				(ø18xØ24x4mm)	(ø18xØ24x4mm)	(ø18xØ24x4mm)	(ø18xØ24x4mm)	(ø18xØ24x4mm)	
	10	8B00 42029	4	Bussola	Bushing	Douille	Buchse	Manguito	
	11	8000 77413	1	Vite	Screw	Vis	Schraube	Tornillo	
	12	8000 42023	2	Dado	Nut	Ecrou	Mutter	Tuerca	
	13	8A00 69138	1	Vite	Screw	Vis	Schraube	Tornillo	
	14	8000 72168	1	Cuscinetto	Bearing	Roulement	Lager	Cojinete	
				(ø12xØ26x16 mm)	(ø12xØ26x16 mm)	(ø12xØ26x16 mm)	(ø12xØ26x16 mm)	(ø12xØ26x16 mm)	
	15	8000 38767	2	Guarnizione	Gasket	Garnitue	Dichtung	Junta	
	16	1511 33302	2	Bussola	Bushing	Douille	Buchse	Manguito	
	17	8A00 62797	1	Vite	Screw	Vis	Schraube	Tornillo	
	18	8000 42022	1	Dado	Nut	Ecrou	Mutter	Tuerca	
	19	8000 01412	2	Ingrassatore	Lubricator	Graisneur	Schmierbüchse	Lubricador	
	20	8A00 75153	1	Spinotto	Gudgeon	Axe	Bolzen	Perno	
	21	8000 42781	4	Cuscinetto	Bearing	Roulement	Lager	Cojinete	
				(ø20xØ26x20 mm)	(ø20xØ26x20 mm)	(ø20xØ26x20 mm)	(ø20xØ26x20 mm)	(ø20xØ26x20 mm)	
	22	8000 32065	4	Guarnizione	Gasket	Garnitue	Dichtung	Junta	
				(ø20xØ26x4 mm)	(ø20xØ26x4 mm)	(ø20xØ26x4 mm)	(ø20xØ26x4 mm)	(ø20xØ26x4 mm)	
	23	8000 90561	2	Anello di tenuta	Seal ring	Bague de retenue	Dichtring	Anillo de retención	
	26	8000 42022	1	Dado	Nut	Ecrou	Mutter	Tuerca	

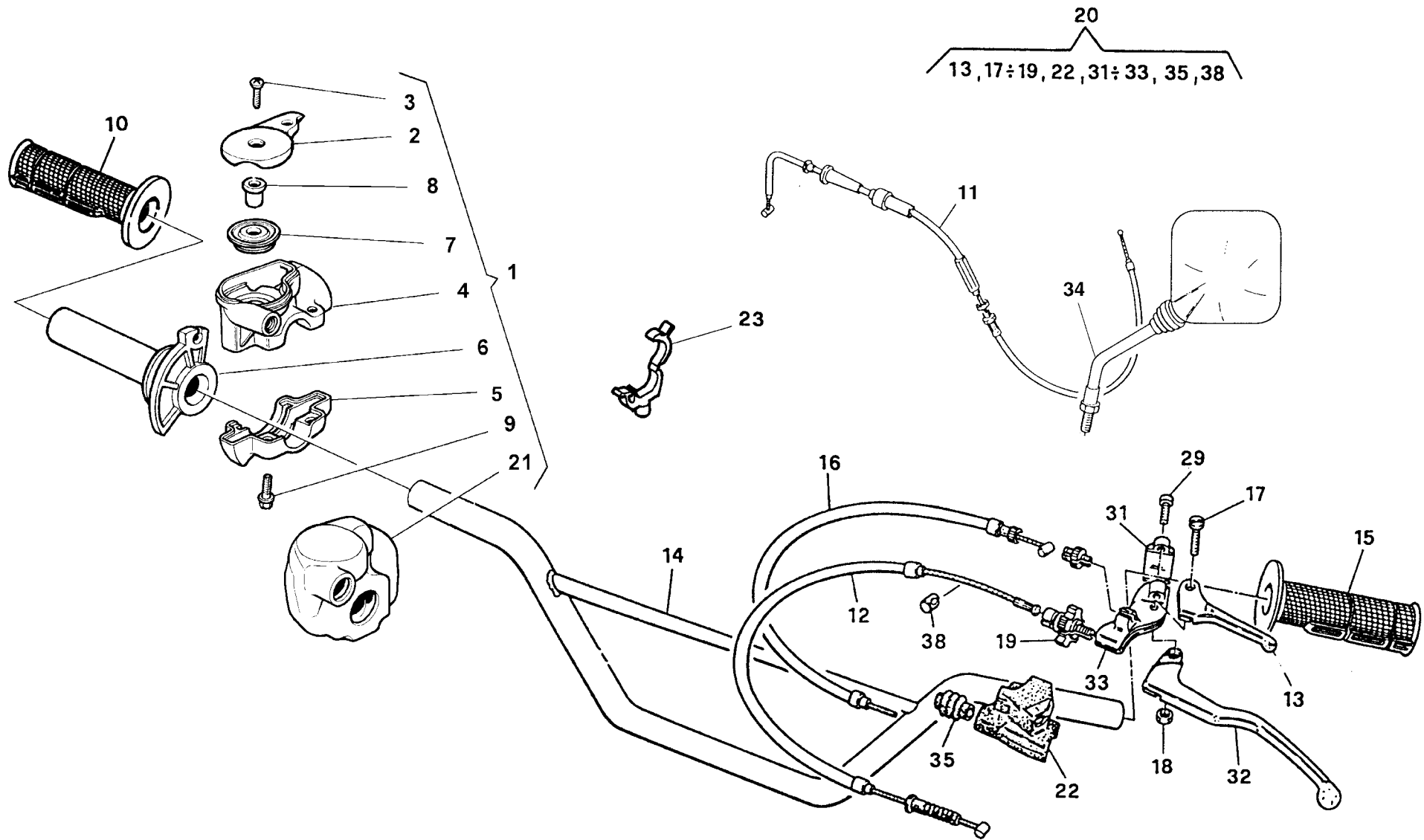



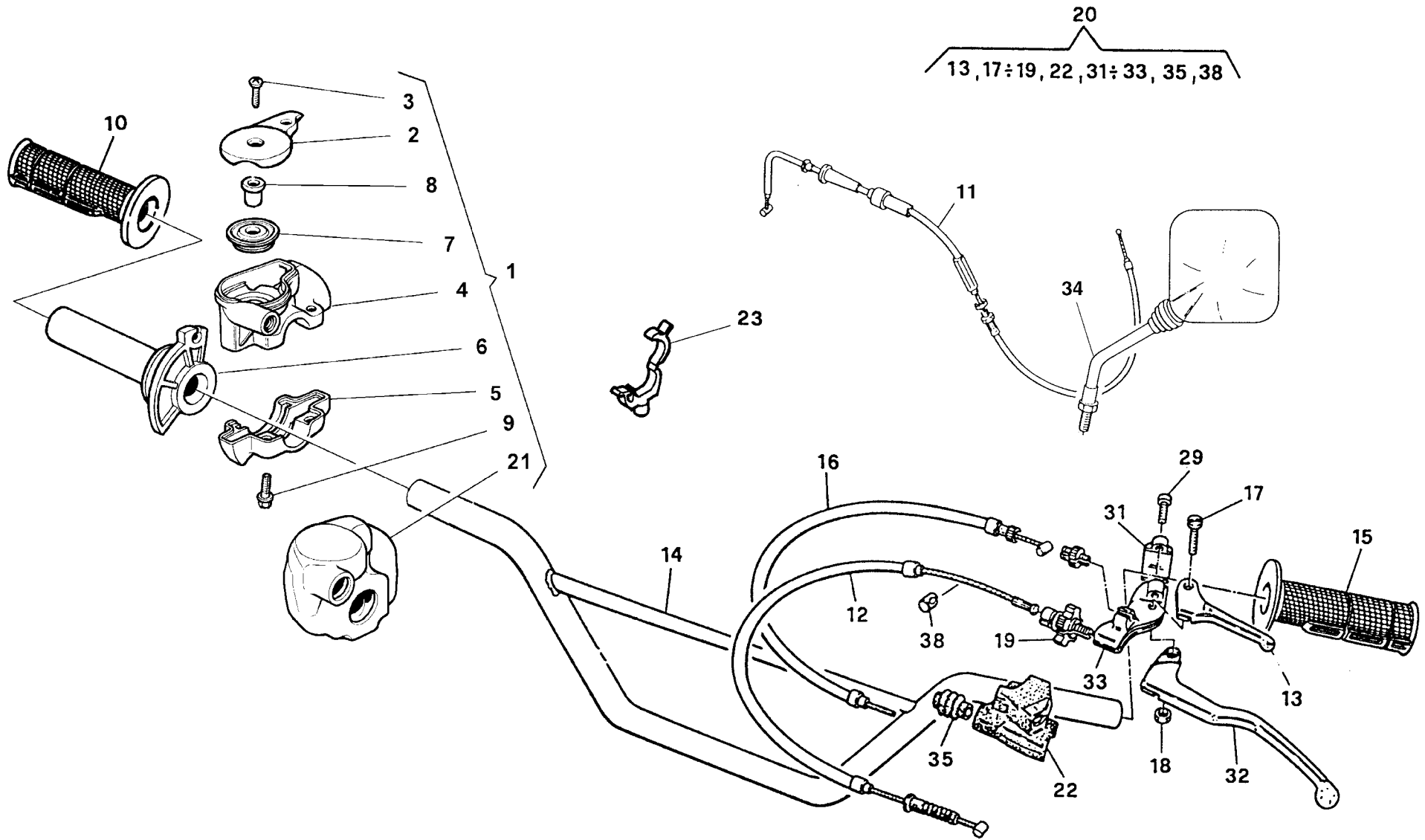





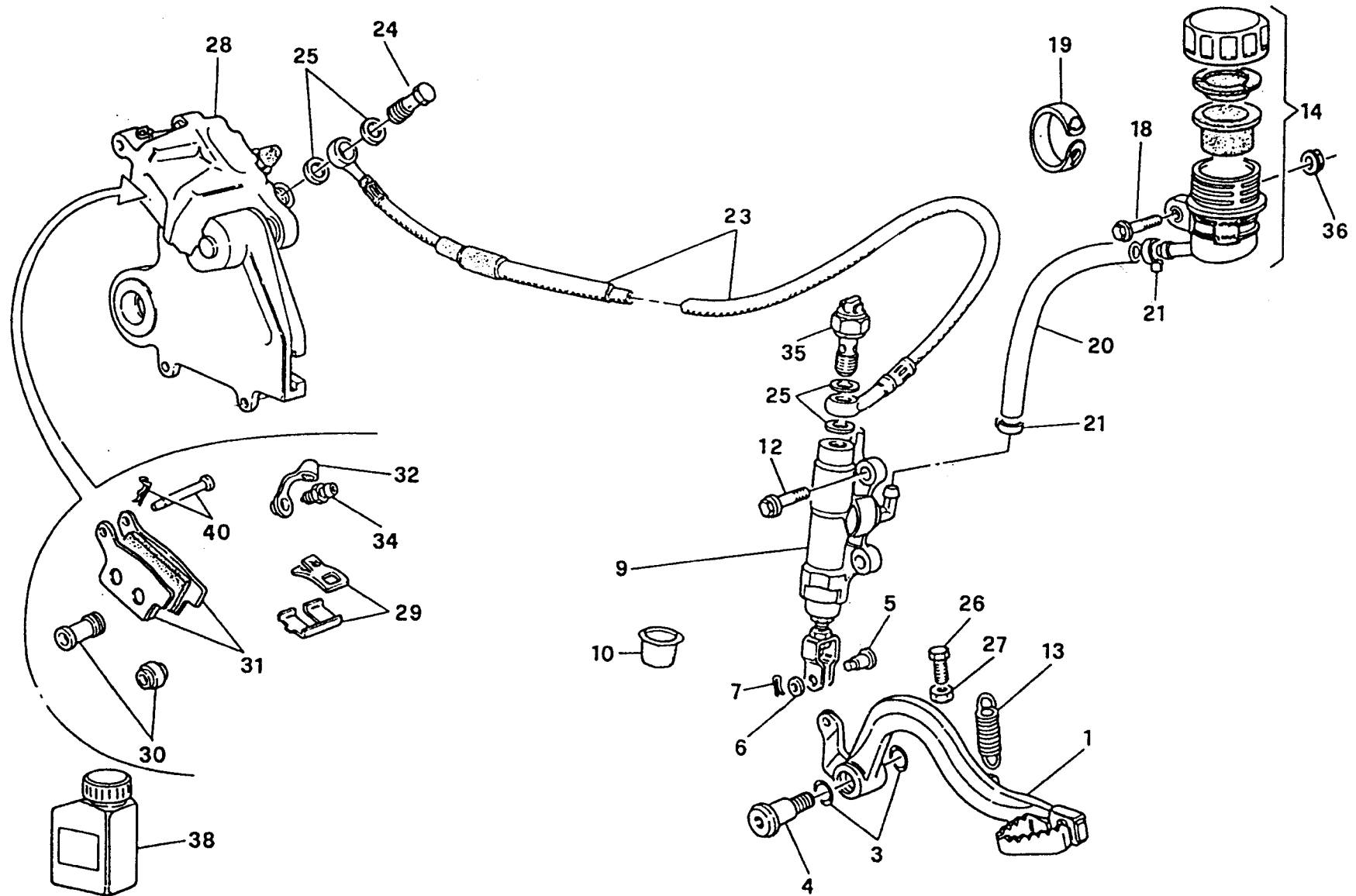

Note Notes Notes Marke Notas	Pos. No. Index	N. Cod. Code No. Nr. Code Code Nr N. Cod.	Q.tà Q.ty Q.te M.ge C.ad	DENOMINAZIONE	NAME	DESIGNATION	BESHREIBUNG	DENOMINACION	Validità Validity Validité Gültig Validez
	1	8A00 64708	1	Leva comando freno	Brake control lever	Levier comm. frein	Bremshebel	Palanca accionamiento freno	
	3	8000 22551	2	Anello OR	O-Ring	Bague OR	O-Ring	Anillo OR	
	4	8000 55902	1	Vite	Screw	Vis	Schraube	Tornillo	
	5	8000 70696	1	Astina	Control rod	Coulisseau	Steuerstange	Varilla	
	6	8000 56377	1	Rosetta	Washer	Rondelle	Scheibe	Arandela	
	7	64N1 20068	1	Copiglia	Split pin	Goupille	Splint	Clavija	
	9	8000 76338	1	Pompa comando freno compl.	Brake pump	Pompe frein	Bremspumpe	Bomba freno	
	10	8000 79075	1	Cuffia	Cap	Capuchons	Kappa	Gorro	
	12	8000 62726	2	Vite	Screw	Vis	Schraube	Tornillo	
	13	8000 55903	1	Molla	Spring	Ressort	Feder	Resorte	
	14	8000 61078	1	Serbatoio olio completo	Oil tank assy	Reservoir huile compl.	Öltank Kpl.	Depósito aceite completo	
	18	8000 62727	1	Vite	Screw	Vis	Schraube	Tornillo	
	19	8000 53724	1	Fascetta	Clamp	Collier	Schelle	Banda	
	20	8A00 70266	1	Tubazione	Pipe	Tuyau	Rohr	Tube	
	21	8000 42349	1	Molletta	Spring	Ressort	Feder	Resorte	
	23	8000 78326	1	Tube mandata olio	Pipe	Tuyau	Rohr	Tube	
	24	8000 57155	1	Vite	Screw	Vis	Schraube	Tornillo	
	25	8000 21480	4	Rosetta di tenuta	Washer	Rondelle	Scheibe	Arandela	
	26	60N1 02511	1	Vite	Screw	Vis	Schraube	Tornillo	
	27	61N1 15062	1	Dado	Nut	Ecrou	Mutter	Tuerca	
	28	8000 77745	1	Pinza freno completa	Brake caliper assy	Pince de frein, compl.	Bremszange, Kpl.	Pinza freno compl.	
	29	8000 85932	1	Gruppo revisione mollette	Spring set	Kit revision ressort	Federsatz	Grupo revis. resorte	
	30	8000 79066	1	Gruppo revisione cuffie	Caps revision set	Groupe revision capuchons	Kappa reparatursatz	Grupo revis. gorro	
	31	8000 79072	1	Coppia pastiglie	Pads pair	Paire plaquettes	Bremsbelagpaar	Pareja pastillas	
R	31	8A00 79072	1	Coppia pastiglie	Pads pair	Paire plaquettes	Bremsbelagpaar	Pareja pastillas	
	32	8000 53259	1	Parapolvere	Dust cover	Para poussière	Staubdeckel	Tapa retención polvo	
	34	8000 60404	1	Gruppo revisione spurgo	Bleeding set	Kit de revision curage	Reinigungsatz	Grupo revis. purga	
	35	8000 37891	1	Interruttore stop posteriore	Stop switch	Interrupteur stop	Stopschalter	Interruptor stop	
	36	8000 44240	1	Dado	Nut	Ecrou	Mutter	Tuerca	
R	38	8000 71445	1	Olio freni	Brake oil	Huile de frein	Bremsöl	Aceite freno	
	40	8000 87153	1	Gruppo revisione perni pastiglie	Pad pin set	Kit revision pivots pastilles	Bremsbelagbolzensatz	Grupo revis. pernos pastillas	

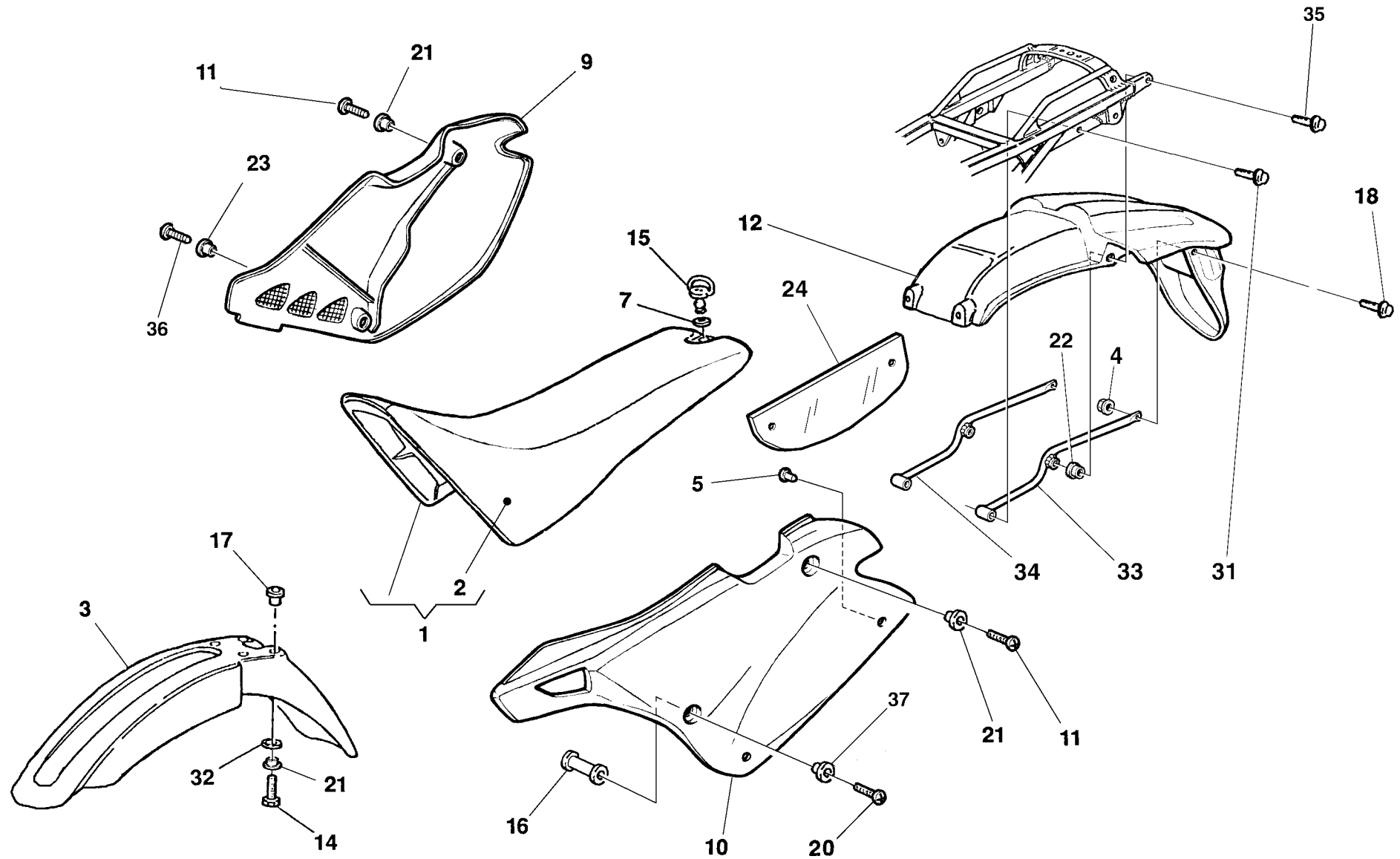

Note Notes Notes Marka Notas	Pos. No. Index	N. Cod. Code No. Nr. Code Code Nr N. Cod.	Q.tà Q.ty Q.te M.ge C.ad	DENOMINAZIONE	NAME	DESIGNATION	BESHREIBUNG	DENOMINACION	Validità Validity Validité Gültig Validez
	1	8A00 92942	1	Sella	Seat	Siège	Sattel	Sillín	
	2	8000 92939	1	Rivestimento sella	Saddle covering	Revetement selle	Sattelverkleidung	Revestimiento sillín	
	3	8000 95684	1	Parafango anteriore	Front mudguard	Garde-boue avant	Vord. Kotfluegel	Guarda-barros delantero	
D	3	80C0 87059	1	Parafango anteriore	Front mudguard	Garde-boue avant	Vord. Kotfluegel	Guarda-barros delantero	
	4	8000 61313	2	Dado	Nut	Ecrou	Mutter	Tuerca	
	5	8000 45490	2	Gommino	Rubber pad	Pièce caoutchouc	Gummstück	Junta de goma	
	7	8000 69149	1	Rosetta elastica	Spring washer	Rondelle élastique	Federscheibe	Arandela elástica	
	9	80A0 92958	1	Pannello destro	R.H. panel	Panneau, D.	Streifen, R.	Panel der.	
	10	80A0 92959	1	Pannello sinistro	L.H. panel	Panneau, G.	Streifen, L.	Panel izq.	
	11	8000 62727	2	Vite	Screw	Vis	Schraube	Tornillo	
	12	8C00 88856	1	Parafango posteriore	Rear mudguard	Garde-boue arriere	Hint.Kotfluegel	Guarda-barros trasero	
	14	8000 62727	2	Vite anteriore	Front screw	Vis avant	Vordere schraube	Tornillo delantero	
	14	8000 62728	2	Vite posteriore	Rear screw	Vis arriere	Hintere schraube	Tornillo trasero	
	15	8000 69148	1	Perno	Pin	Pivot	Bolzen	Perno	
	16	1519 76703	1	Distanziale	Spacer	Entretoise	Distanzstück	Separador	
	17	8A00 07001	2	Distanziale	Spacer	Entretoise	Distanzstück	Separador	
	18	8000 62728	2	Vite (M6x20 mm)	Screw (M6x20 mm)	Vis (M6x20 mm)	Schraube (M6x20 mm)	Tornillo (M6x20 mm)	
	20	8C00 67545	1	Vite	Screw	Vis	Schraube	Tornillo	
	21	8000 69429	6	Bussola	Bushing	Douille	Buchse	Manguito	
	22	8000 69429	2	Bussola	Bushing	Douille	Buchse	Manguito	
	23	8A00 69429	1	Bussola	Bushing	Douille	Buchse	Manguito	
	24	8000 94267	1	Protezione	Guard	Protection	Schutz	Protección	
	31	8000 62727	2	Vite (M6x16 mm)	Screw (M6x16 mm)	Vis (M6x16 mm)	Schraube (M6x16 mm)	Tornillo (M6x16 mm)	
	32	8000 48814	4	Rosetta	Washer	Rondelle	Scheibe	Arandela	
	33	8000 95411	1	Rinforzo sx	L.H. stiffener	Renfort gauche	Linke Versärkung	Refuerzo izq.	
	34	8000 95412	1	Rinforzo dx	R.H. stiffener	Renfort droite	RechteVersärkung	Refuerzoder.	
	35	8000 62729	2	Vite (M6x25 mm)	Screw (M6x25 mm)	Vis (M6x25 mm)	Schraube (M6x25 mm)	Tornillo (M6x25 mm)	
	36	8000 62728	2	Vite (M6x20 mm)	Screw (M6x20 mm)	Vis (M6x20 mm)	Schraube (M6x20 mm)	Tornillo (M6x20 mm)	
	37	8000 69429	2	Bussola	Bushing	Douille	Buchse	Manguito	





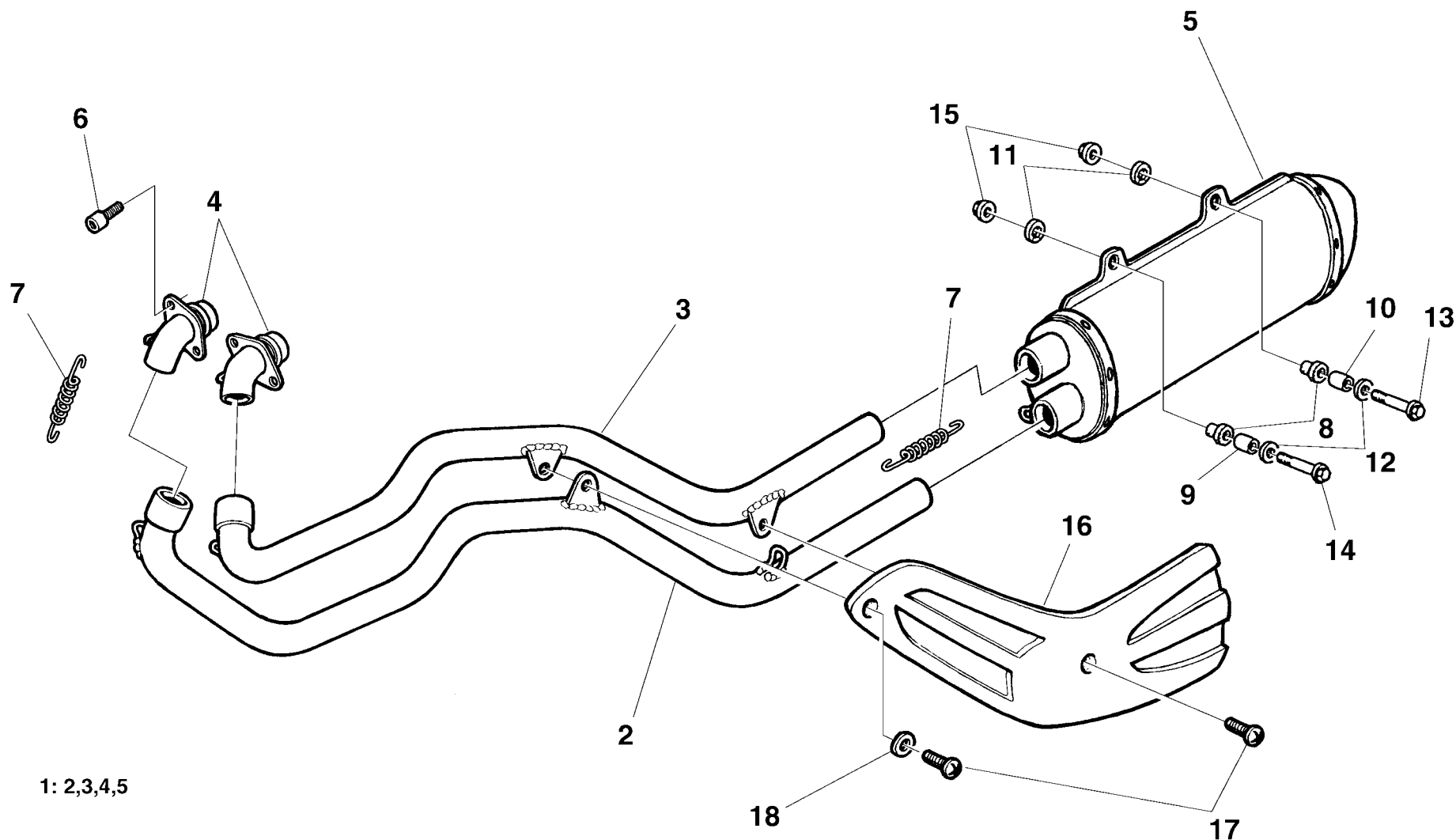





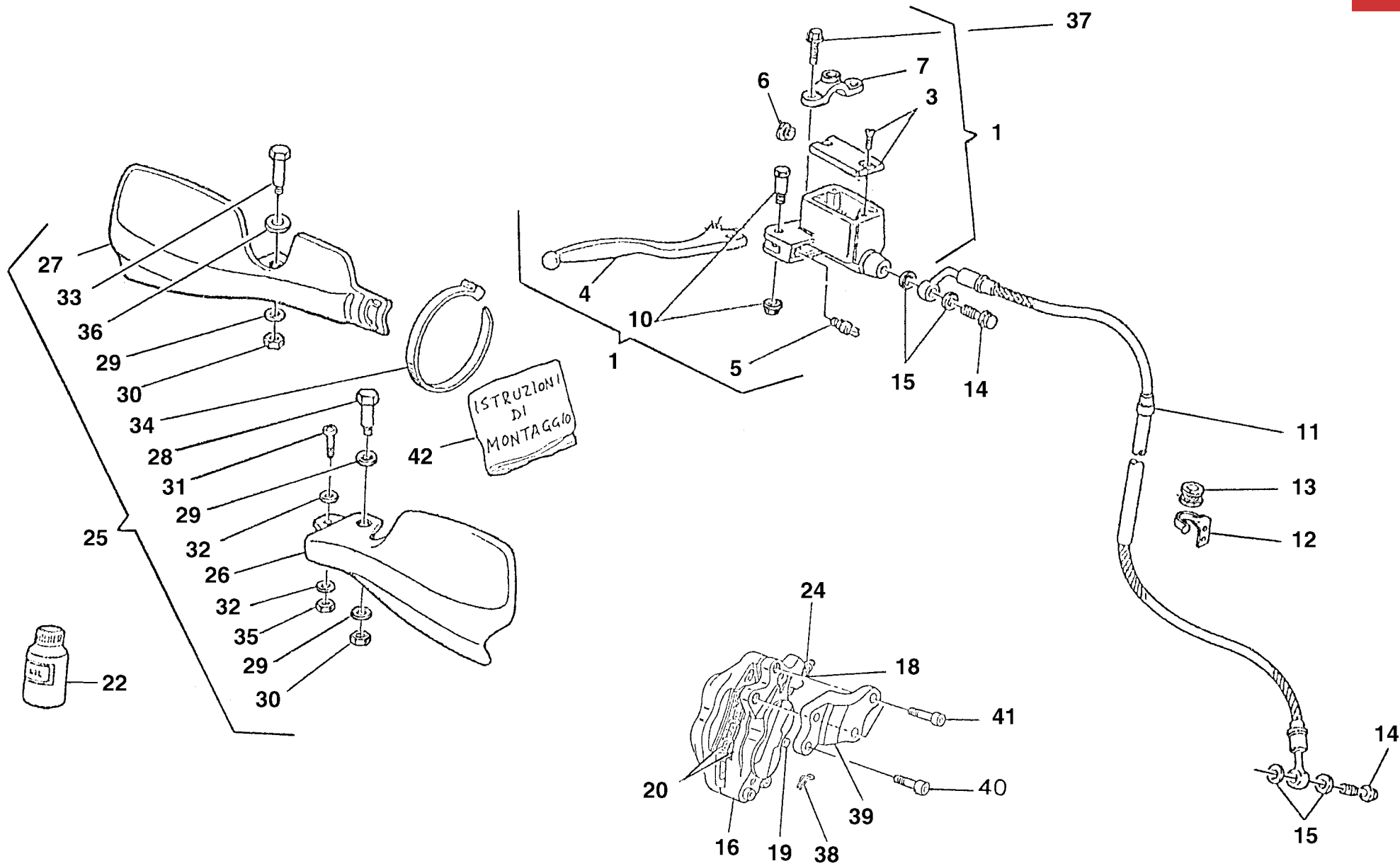

16: 18-19-20-24-38



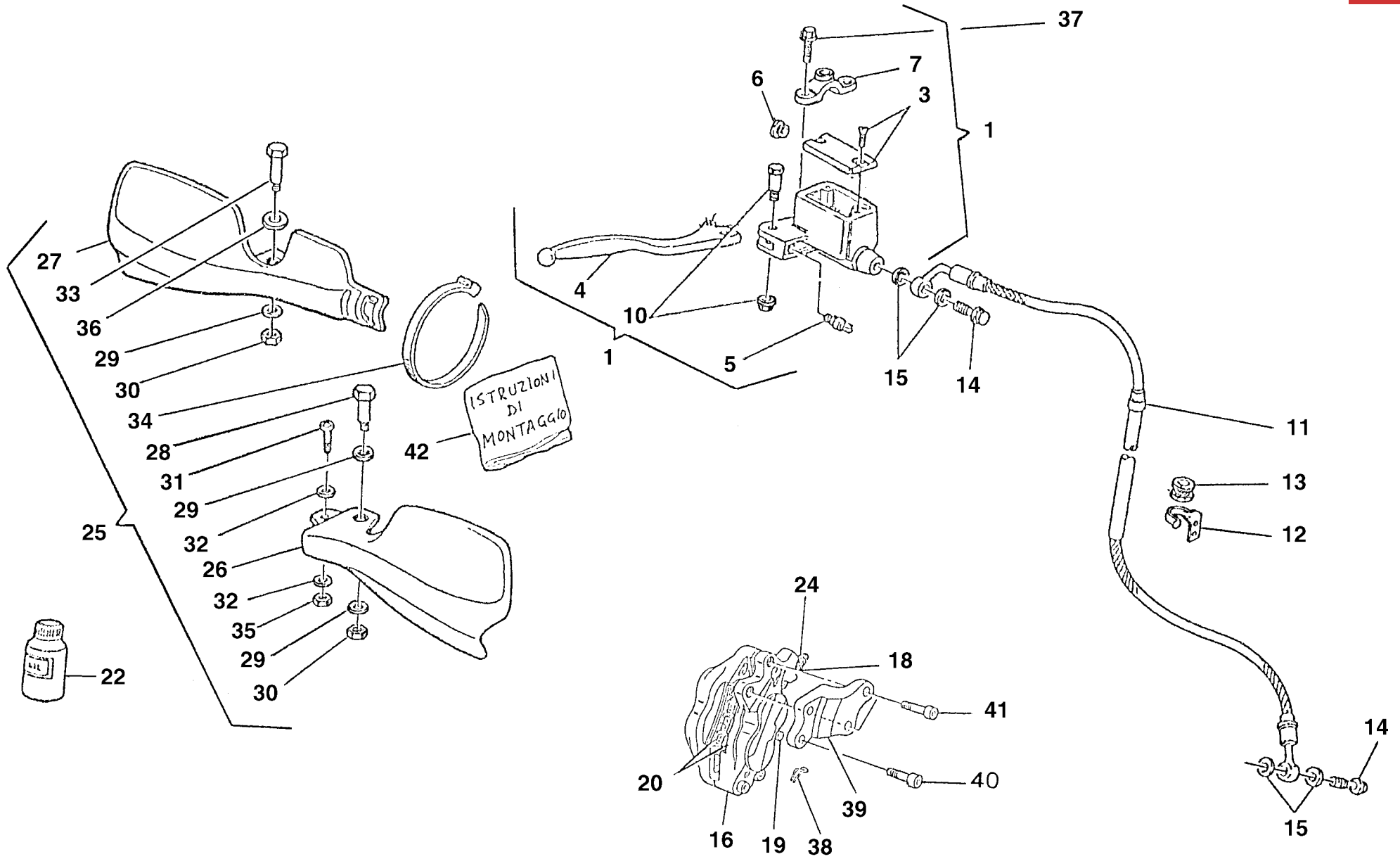

16: 18-19-20-24-38



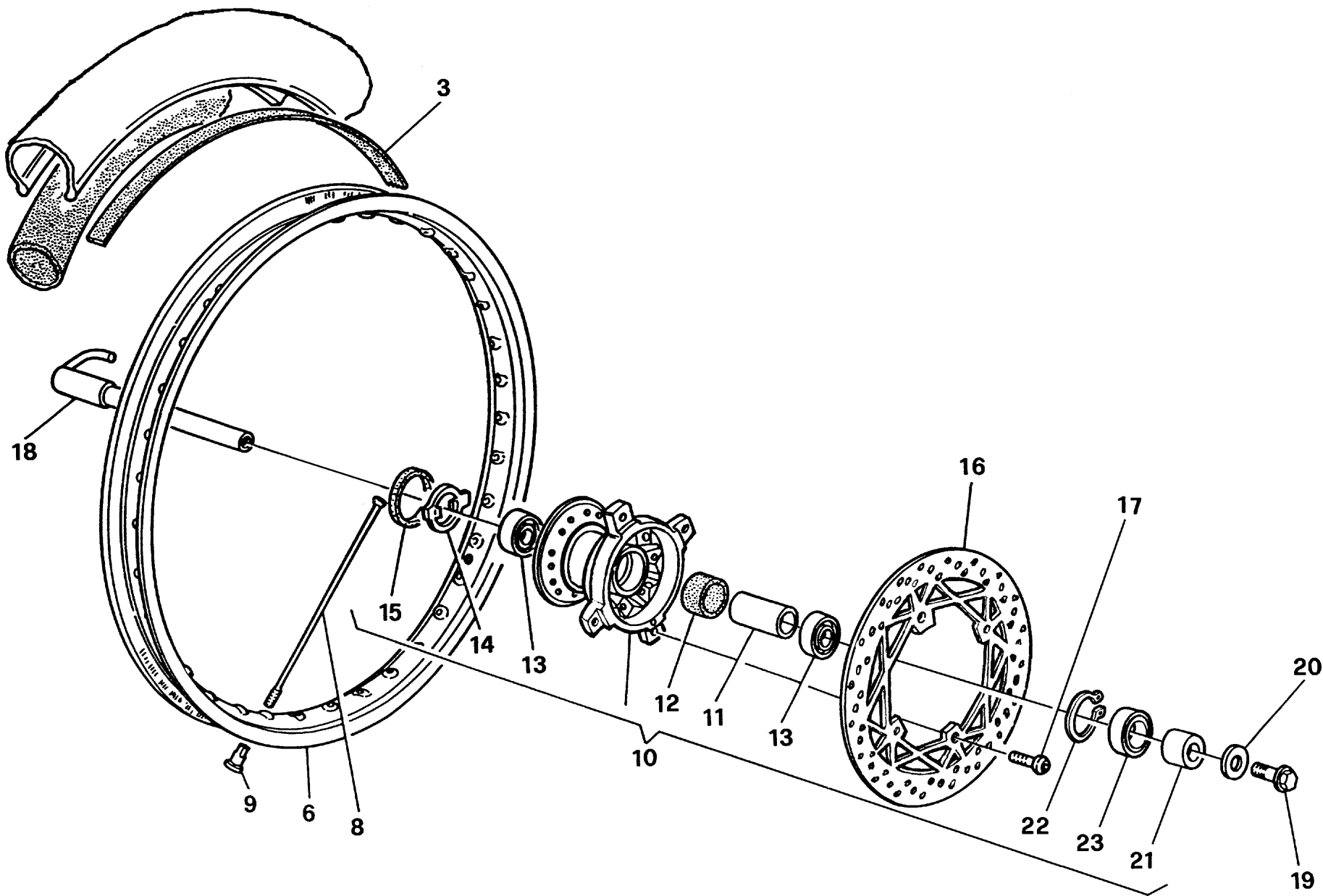



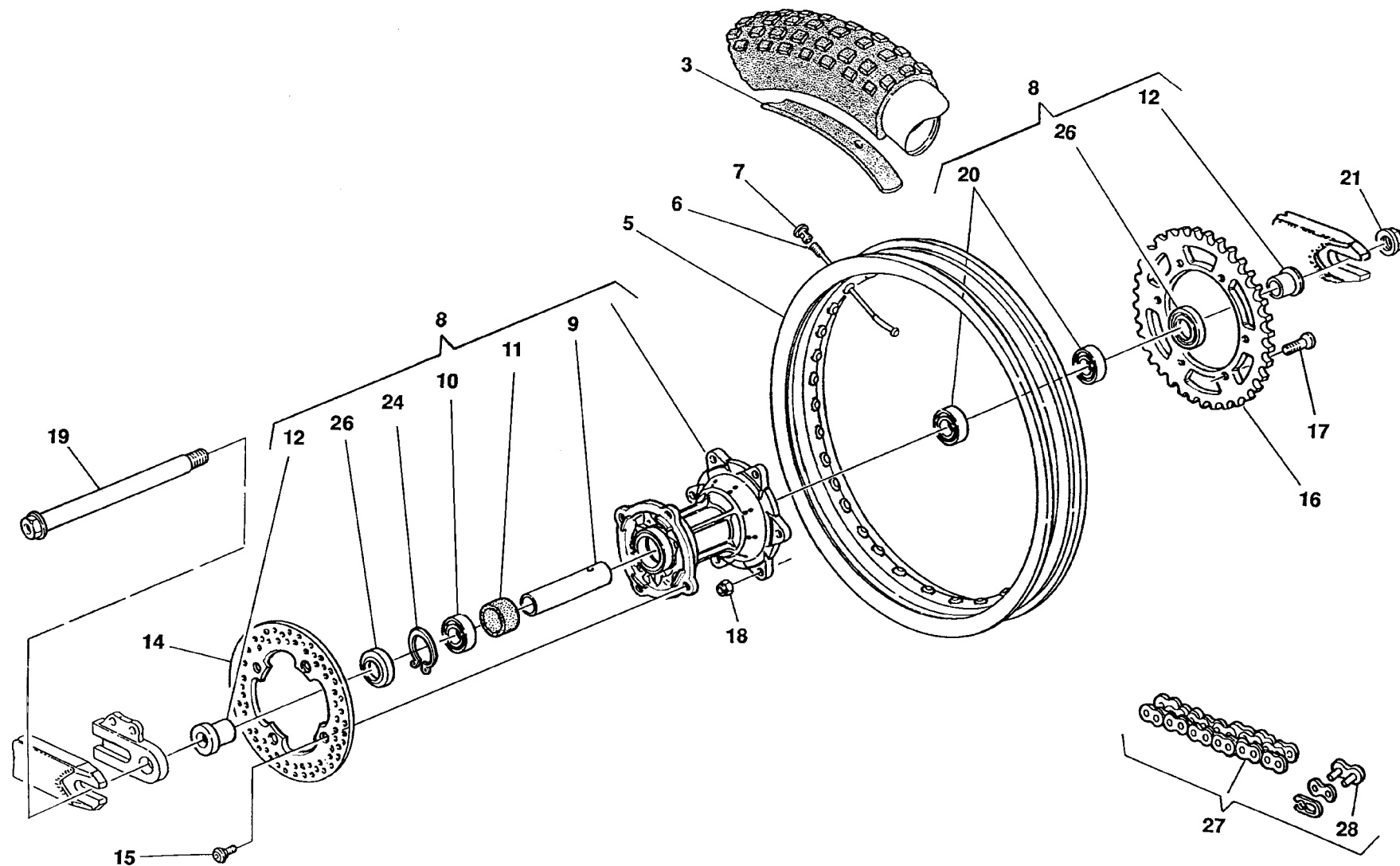

Note Notes Notes Marke Notas	Pos. No. Index Pos.	N. Cod. Code No. Nr. Code Code Nr N. Cod.	Q.tà Q.ty Q.te M.ge C.ad	DENOMINAZIONE	NAME	DESIGNATION	BESHREIBUNG	DENOMINACION	Validità Validity Validité Gültig Validez
	3	8B00 82879	1	Fascia copriraggi	Rim strip	Bande	Band	Banda	
	5	8000 94713	1	Cerchio (4,25x17")	Rim (4,25x17")	Jante(4,25x17")	Felge(4,25x17")	Llanta (4,25x17")	
	6	8000 94757	36	Raggio lato freno	Spoke brake side	Bras	Speiche	Radio	
	6	8000 95341	36	Raggio lato corona	Spoke sprocket side	Bras	Speiche	Radio	
	7	69N4 29005	36	Nipplo	Nipple	Nipple	Nippel	Nipple	
	8	8000 94700	1	Mozzo completo	Hub assy	Moyeau compl.	Radnabe, Kpl.	Cubo compl.	
	9	8A00 86938	1	Distanziale	Spacer	Entretoise	Distanzstück	Separador	
	10	8B00 26846	1	Cuscinetto (ø25xØ47x16 mm)	Bearing (ø25xØ47x16 mm)	Roulement (ø25xØ47x16 mm)	Kugellager (ø25xØ47x16 mm)	Cojinete (ø25xØ47x16 mm)	
A	10	8D00 26846	1	Cuscinetto (ø25xØ47x16 mm)	Bearing (ø25xØ47x16 mm)	Roulement (ø25xØ47x16 mm)	Kugellager (ø25xØ47x16 mm)	Cojinete (ø25xØ47x16 mm)	
	11	8000 92797	1	Porta distanziale	Spacer	Entretoise	Distanzstück	Separador	
	12	8A00 92413	2	Distanziale	Spacer	Entretoise	Distanzstück	Separador	
	14	8000 88887	1	Disco freno	Brake disc	Disque frein	Bremsscheibe	Disco freno	
	15	8000 55878	4	Vite	Screw	Vis	Schraube	Tornillo	
S	16	8B00 91498	1	Corona (Z = 48)	Ring gear (Z = 48)	Couronne (Z = 48)	Kranz (Z = 48)	Corona (Z = 48)	
R	16	8A00 91498	1	Corona (Z = 47)	Ring gear (Z = 47)	Couronne (Z = 47)	Kranz (Z = 47)	Corona (Z = 47)	
R	16	8C00 91498	1	Corona (Z = 49)	Ring gear (Z = 49)	Couronne (Z = 49)	Kranz (Z = 49)	Corona (Z = 49)	
R	16	8D00 91498	1	Corona (Z = 50)	Ring gear (Z = 50)	Couronne (Z = 50)	Kranz (Z = 50)	Corona (Z = 50)	
	17	8B00 40796	6	Vite	Screw	Vis	Schraube	Tornillo	
	18	8000 43928	6	Dado	Nut	Ecrou	Mutter	Tuierca	
	19	8C00 72621	1	Perno	Pin	Pivot	Bolzen	Perno	
A	19	8A00 72621	1	Perno	Pin	Pivot	Bolzen	Perno	
	20	8A00 26846	2	Cuscinetto (ø25xØ47x12 mm)	Bearing (ø25xØ47x12 mm)	Roulement (ø25xØ47x12 mm)	Kugellager (ø25xØ47x12 mm)	Cojinete (ø25xØ47x12 mm)	
A	20	8C00 26846	2	Cuscinetto (ø25xØ47x12 mm)	Bearing (ø25xØ47x12 mm)	Roulement (ø25xØ47x12 mm)	Kugellager (ø25xØ47x12 mm)	Cojinete (ø25xØ47x12 mm)	



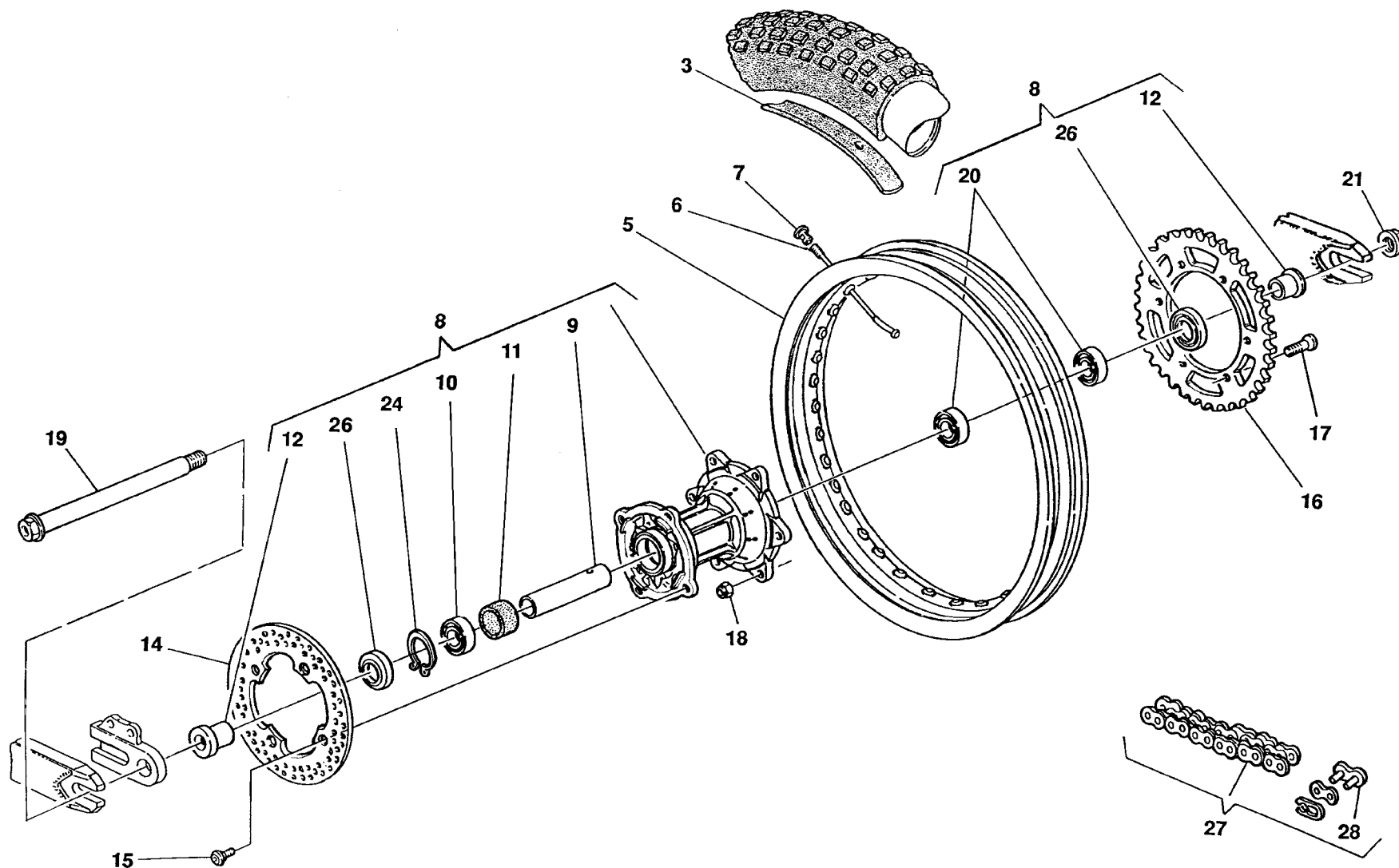



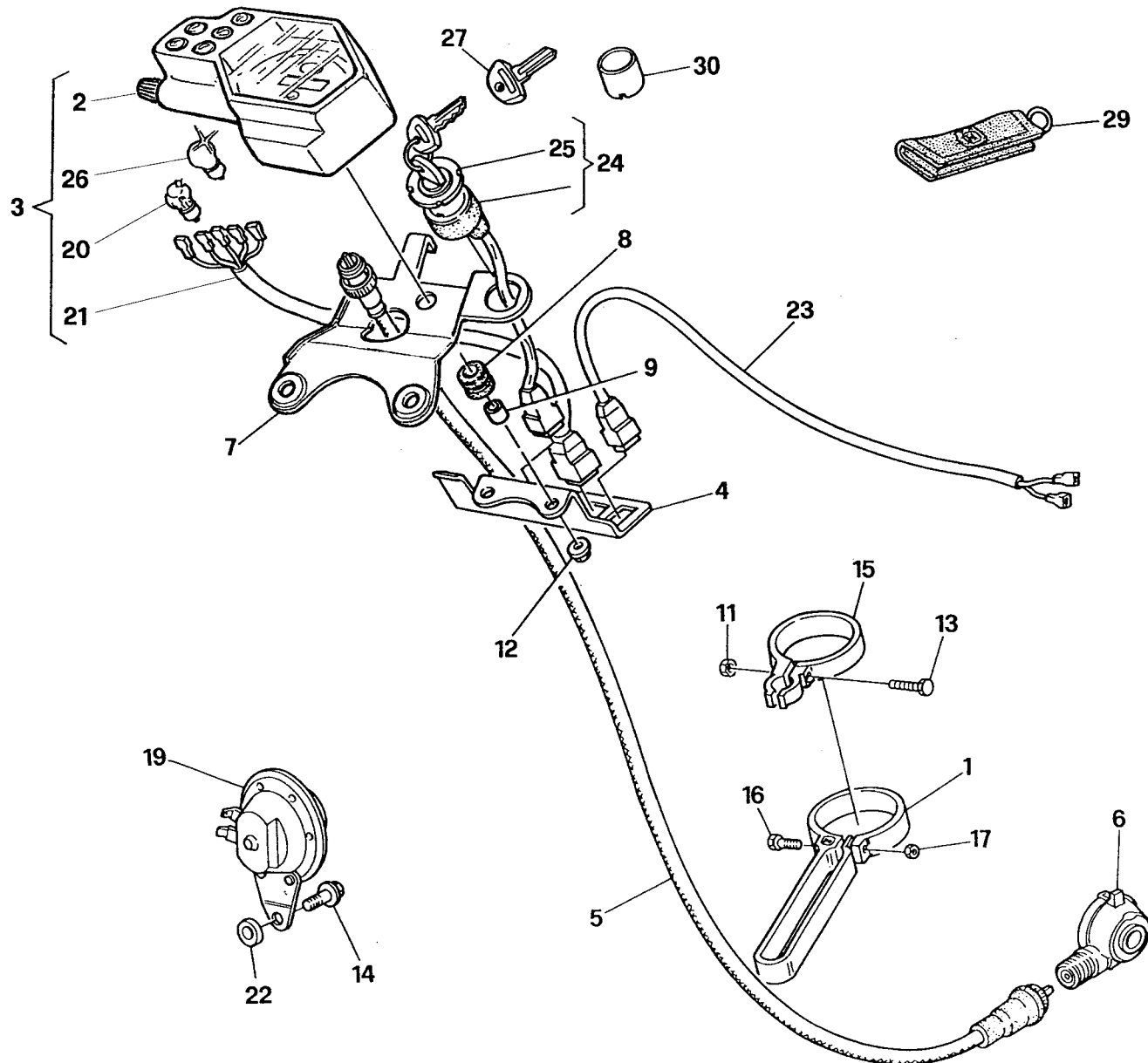

Note Notes Notes Marke Notas	Pos. No. N. Index Pos.	N. Cod. Code No. Nr. Code Code Nr N. Cod.	Q.tà Q.ty Q.te M.ge C.ad	DENOMINAZIONE	NAME	DESIGNATION	BESHREIBUNG	DENOMINACION	Validità Validity Validité Gültig Validez
	1	8AA0 65340	1	Fascetta	Clamp	Collier	Schelle	Banda	
	2	8000 87086	1	Contachilometri	Speedometer	Compteur-km	Tachometer	Cuenta-kilómetros	
	3	8000 87849	1	Ass. contachilometri	Speedometer assy	Compteur-km. compl.	Tachometer kpl.	Cuenta-kilómetros compl.	
	4	8000 69428	1	Piastra	Plate	Plaque	Platte	Placa	
	5	8C00 71759	1	Trasmissione contachilometri	Speedometer cable	Câble compteur - km	Tachokabel	Cable cuenta-kilómetros	
	6	8000 88386	1	Rinvio contachilometri	Odometer transm.	Renvoi compte-km.	Vorgelege Kilometerzähler	Reenvío cuenta-kilómetros	
	7	8000 87847	1	Piastra	Plate	Plaque	Platte	Placa	
	8	8000 62651	2	Antivibrante	Silent-block	Antivibration	Schwingungsdämpfer	Anti-vibrador	
	9	8000 25053	2	Distanziale	Spacer	Entretoise	Distanzstück	Separador	
	11	8000 56443	1	Dado	Nut	Ecrou	Mutter	Tuerca	
	12	8000 61313	2	Dado	Nut	Ecrou	Mutter	Tuerca	
	14	8000 62726	1	Vite	Screw	Vis	Schraube	Tornillo	
	15	80A0 70581	1	Fascetta	Clamp	Collier	Schelle	Banda	
	16	8B00 66525	2	Vite	Screw	Vis	Schraube	Tornillo	
	17	61N1 15192	1	Dado	Nut	Ecrou	Mutter	Tuerca	
E	19	8000 90107	1	Avvisatore acustico	Horn	Signal acoustique	Hupe	Avisador acústico	
	19	8000 70278	1	Avvisatore acustico	Horn	Signal acoustique	Hupe	Avisador acústico	
	20	8000 20602	5	Lampadina (12V/1,2W)	Lamp (12V/1,2W)	Lampe (12V/1,2W)	Lampe (12V/1,2W)	Lamparilla (12V/1,2W)	
	21	8000 87088	1	Cavi	Cable	Cable	Kabel	Cable	
	22	8000 60969	1	Rosetta	Washer	Rondelle	Scheibe	Arandela	
	23	8000 75477	1	Cavi	Cable	Cable	Kabel	Cable	
	24	8000 74259	1	Interr. accensione completo	Ignition switch assy	Interrupteur pour allum. comp.	Schalter, Kpl.	Interruptor encendido compl.	
	25	8000 74258	1	Ghiera	Ring nut	Embout	Nutmutter	Virola	
	26	8000 60033	2	Lampadina (12V/2W)	Lamp (12V/2W)	Lampe (12V/2W)	Lampe (12V/2W)	Lamparilla (12V/2W)	
	27	8000 38210	1	Chiave grezza	Raw kei	Cléf primitive	Schlüssel	Llave greggia	
	29	8000 72037	1	Porta chiavi	Key-ring	Porte-clefs	Schlüsselring	Llavero	
	30	8000 50569	1	Distanziale	Spacer	Entretoise	Distanzstück	Separador	

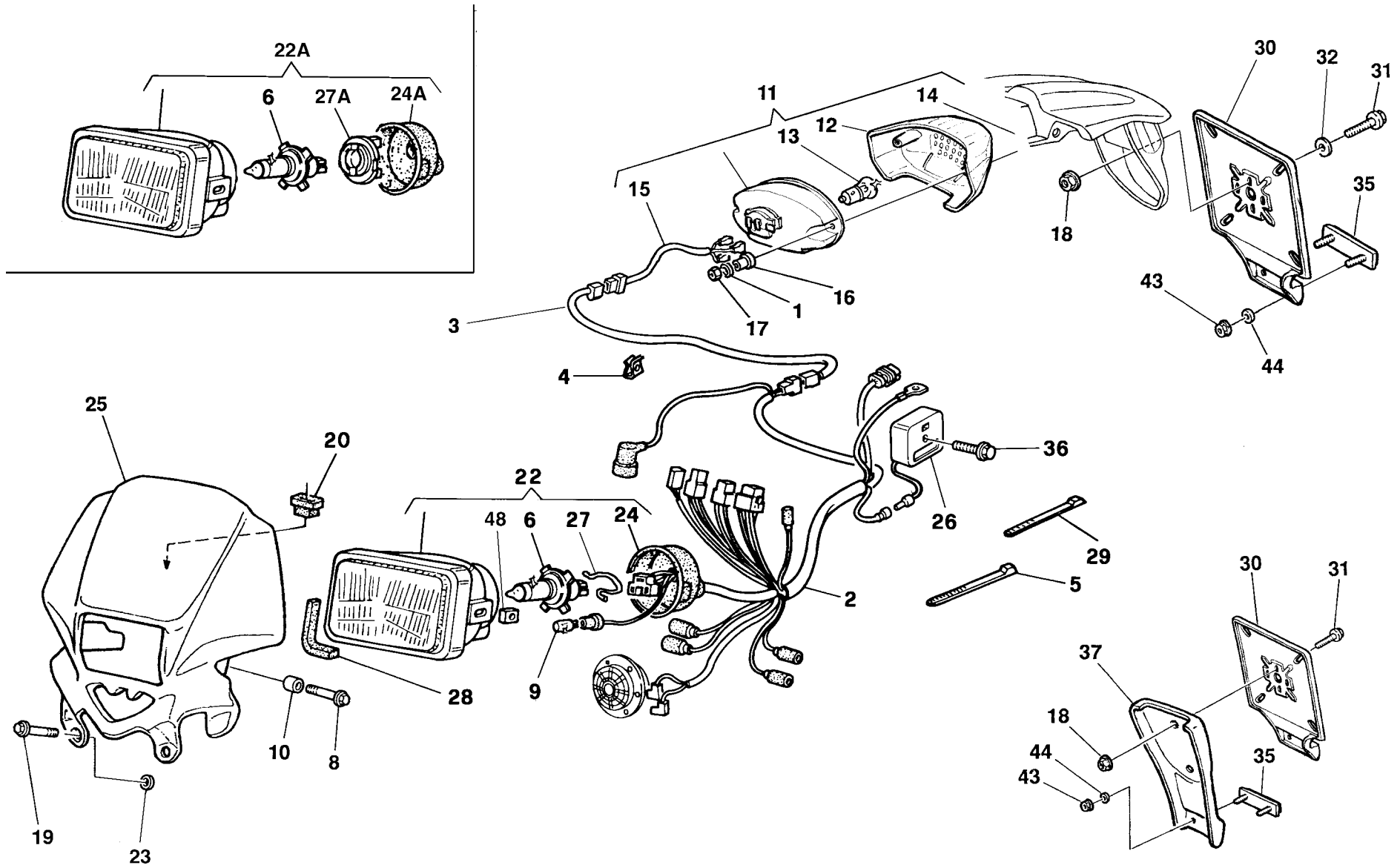



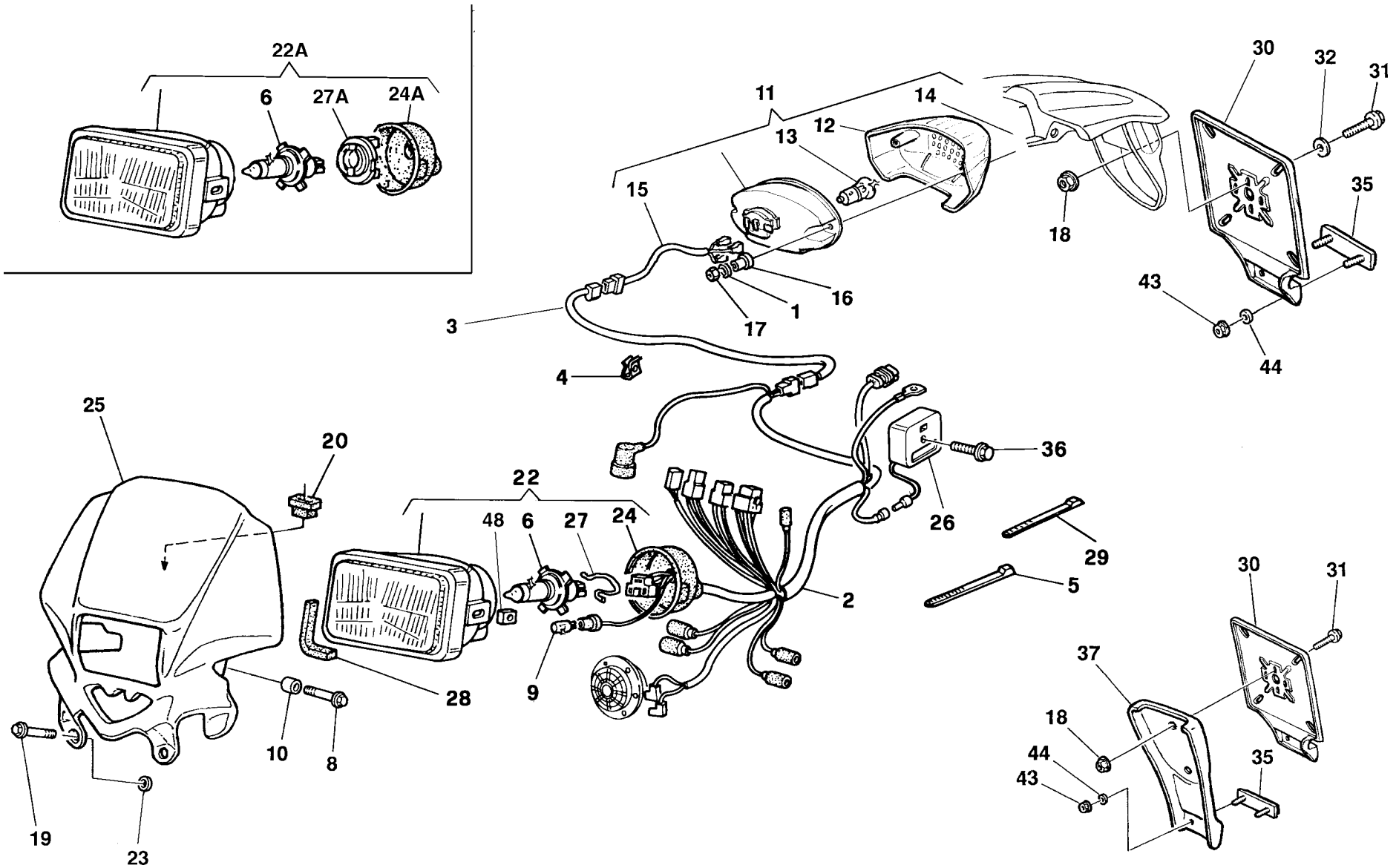





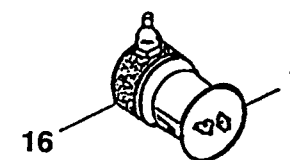
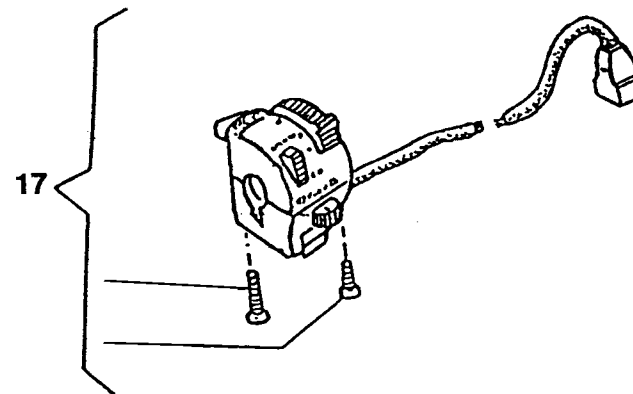
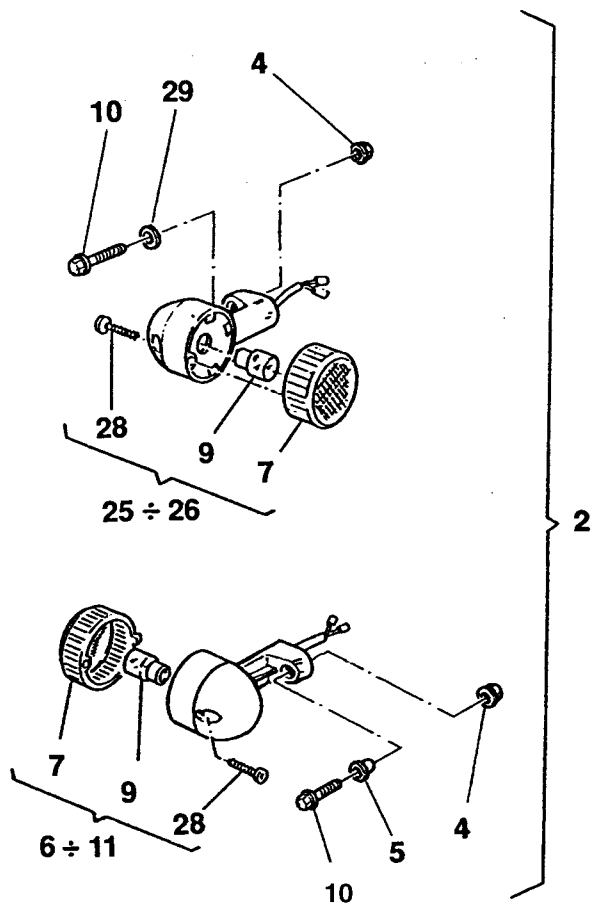



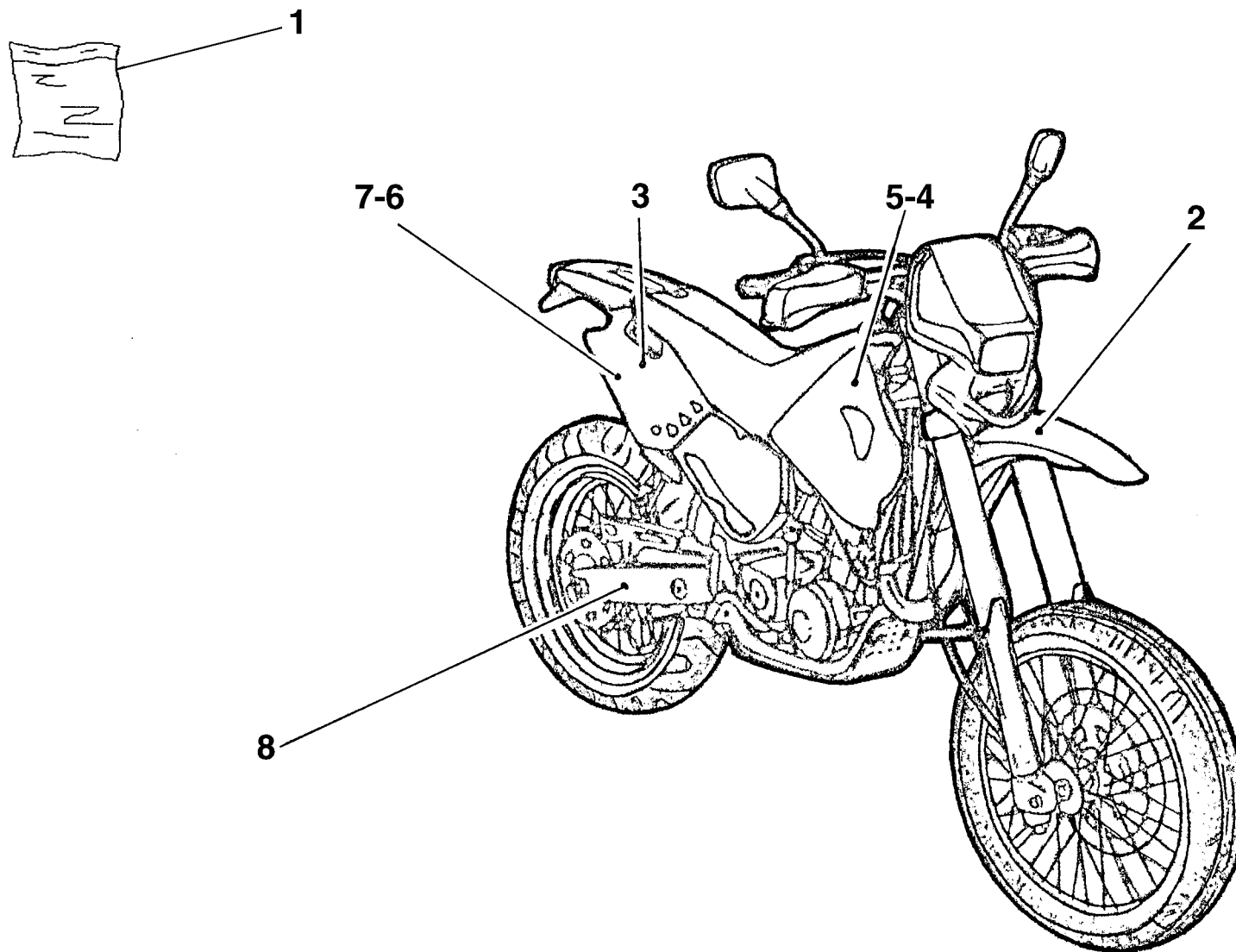



DISEGNO DRAWING DESSIN ZEICHNUNG DIBUJO	TAVOLA DRAWING TABLE BILD TABLA	INDEX NO. POS. N. INDICE	DISEGNO DRAWING DESSIN ZEICHNUNG DIBUJO	TAVOLA DRAWING TABLE BILD TABLA	INDEX NO. POS. N. INDICE	DISEGNO DRAWING DESSIN ZEICHNUNG DIBUJO	TAVOLA DRAWING TABLE BILD TABLA	INDEX NO. POS. N. INDICE	DISEGNO DRAWING DESSIN ZEICHNUNG DIBUJO	TAVOLA DRAWING TABLE BILD TABLA	INDEX NO. POS. N. INDICE	DISEGNO DRAWING DESSIN ZEICHNUNG DIBUJO	TAVOLA DRAWING TABLE BILD TABLA	INDEX NO. POS. N. INDICE
0660 49053	6	42	1611 70801	7	39	1615 14104	3	19	60N1 02557	2	35	8000 01412	16	19
1511 24901	14	19	1611 71501	8	44	1615 15601	3	10	60N1 02866	7	16	8000 02124	3	1
1511 33302	16	16	1611 71701	8	25	1615 23801	2	16	60N1 02900	7	49	8000 04103	10	48
1513 07001	12	2	1611 74601	7	38	1615 26602	3	4	60N1 02927	3	33	8000 04104	10	49
1513 41401	21	11	1611 81604	6	14	1615 27501	9	14	60N1 04134	20	7	8000 08536	2	44
1513 71301	4	4	1611 83701	8	27	1615 28801	2	11	60N1 07335	2	22	8000 08536	14	10
1513 71401	8	47	1612 35701	8	43	1615 29401	2	10	60N1 07335	7	69	8000 12029	10	22
1513 72201	6	29	1612 36101	8	49	1615 29601	2	13	60N1 07350	20	15	8000 12030	10	21
1513 72602	6	3	1612 36201	8	18	1615 30301	2	17	60N4 07335	21	6	8000 12033	10	18
1513 72602	7	19	1612 36301	8	21	1615 31502	8	3	60N4 95615	25	14	8000 12034	10	17
1513 74301	21	12	1612 36502	8	41	1615 33201	2	4	61N1 15062	8	8	8000 12045	10	27
1514 10702	21	8	1612 38401	8	33	1615 34801	7	14	61N1 15062	18	27	8000 12046	10	28
1514 13401	1	6	1612 38801	8	46	1615 35101	2	15	61N1 15191	22	35	8000 12048	10	30
1515 50601	14	34	1612 39001	8	23	1615 35801	2	3	61N1 15192	24	17	8000 12451	10	61
1515 59101	1	5	1612 41501	8	48	1615 35902	2	18	61N1 15195	2	1	8000 17810	14	21
1515 80301	11	10	1612 48001	8	20	1615 35902	7	18	61N1 15195	3	22	8000 18048	25	17
1517 94701	1	1	1612 48101	8	19	1615 38201	9	4	62N0 15682	6	43	8000 18422	2	32
1517 94902	1	8	1612 69901	8	39	1615 38301	9	10	62N1 15503	10	57	8000 19768	6	25
1519 65301	1	2	1612 84201	8	22	1615 38801	8	30	62N1 15504	6	9	8000 19789	2	49
1519 76703	19	16	1614 46901	7	58	1615 39001	10	44	62N1 15504	12	35	8000 20536	14	14
1519 80501	1	4	1614 58901	6	32	1615 39101	7	32	62N1 15506	22	36	8000 20536	14	41
1519 84701	1	13	1614 58901	7	11	1615 39301	3	15	62N1 15519	5	28	8000 20602	24	20
1519 88201	1	12	1614 59001	7	7	1615 40702	2	2	62N1 15524	14	5	8000 21375	3	29
1610 77601	7	8	1614 72801	6	8	1615 40802	3	23	62N1 15547	25	44	8000 21480	6	20
1610 77701	6	33	1615 01403	6	27	1616 36201	7	37	62N1 15567	3	37	8000 21480	18	25
1610 77701	7	10	1615 02301	2	14	1617 95501	2	37	62N1 15658	3	6	8000 21480	22	15
1611 08401	7	73	1615 02501	2	12	1619 69801	1	16	62N4 15548	9	13	8000 21535	8	16
1611 08501	7	67	1615 03601	3	17	60N1 01048	10	55	63N0 16374	8	58	8000 22551	18	3
1611 21601	7	27	1615 04201	3	13	60N1 01081	8	17	64N1 20048	12	36	8000 23110	6	37
1611 27101	7	28	1615 04301	3	8	60N1 01219	13	62	64N1 20068	12	8	8000 23979	10	13
1611 65003	7	13	1615 04501	3	11	60N1 02487	9	8	64N1 20068	18	7	8000 23981	10	9
1611 67702	7	35	1615 04901	3	7	60N1 02504	7	75	66N0 21205	7	31	8000 23983	10	20
1611 68001	7	33	1615 08401	3	27	60N1 02509	7	50	66N0 21208	7	70	8000 23985	10	16
1611 68101	7	34	1615 08501	3	28	60N1 02510	2	34	66N0 21211	6	21	8000 23990	10	33
1611 68401	7	24	1615 09501	3	12	60N1 02510	6	15	66N0 21211	8	24	8000 24319	2	48
1611 68601	7	21	1615 09601	3	9	60N1 02511	18	26	66N0 21270	22A	22	8000 25053	24	9
1611 69201	7	22	1615 09801	4	3	60N1 02512	7	47	66N0 21272	23	24	8000 26884	6	12
1611 69901	8	32	1615 10501	7	15	60N1 02513	6	6	69N4 29004	22A	9	8000 26970	7	20
1611 70101	8	40	1615 11601	6	26	60N1 02513	7	54	69N4 29005	23	7	8000 27960	7	45
1611 70401	7	61	1615 12301	3	24	60N1 02513	9	6	6BN0 21509	8	15	8000 28182	6	4
1611 70601	7	62	1615 12802	3	21	60N1 02515	6	13	8000 01199	20	6	8000 28798	10	25
1611 70801	2	8	1615 13302	1	3	60N1 02520	6	7	8000 01412	14	55	8000 28799	10	24

DISEGNO DRAWING DESSIN ZEICHNUNG DIBUJO	TAVOLA DRAWING TABLE BILD TABLA	INDEX NO. POS. N. INDICE	DISEGNO DRAWING DESSIN ZEICHNUNG DIBUJO	TAVOLA DRAWING TABLE BILD TABLA	INDEX NO. POS. N. INDICE	DISEGNO DRAWING DESSIN ZEICHNUNG DIBUJO	TAVOLA DRAWING TABLE BILD TABLA	INDEX NO. POS. N. INDICE	DISEGNO DRAWING DESSIN ZEICHNUNG DIBUJO	TAVOLA DRAWING TABLE BILD TABLA	INDEX NO. POS. N. INDICE	DISEGNO DRAWING DESSIN ZEICHNUNG DIBUJO	TAVOLA DRAWING TABLE BILD TABLA	INDEX NO. POS. N. INDICE
8000 29043	12	43	8000 40580	10	26	8000 46893	15	29	8000 57155	22	14	8000 60577	7	63
8000 30319	20	2	8000 40717	25	42	8000 47422	7	25	8000 57196	4	24	8000 60577	7	76
8000 30326	8	36	8000 40717	25	43	8000 47662	22	32	8000 57242	5	13	8000 60873	5	23
8000 31271	7	66	8000 40813	20	17	8000 47708	2	20	8000 57413	10	45	8000 60898	12	40
8000 32065	16	22	8000 41459	12	34	8000 47763	7	53	8000 57511	26	1	8000 60898	21	17
8000 32865	10	34	8000 41922	12	22	8000 47824	17	17	8000 58140	7	68	8000 60969	21	18
8000 32866	10	32	8000 42022	15	31	8000 48138	8	13	8000 58207	25	33	8000 60969	24	22
8000 32867	10	39	8000 42022	16	18	8000 48772	22A	20	8000 59289	14	24	8000 61078	18	14
8000 33109	10	7	8000 42022	16	26	8000 48773	22A	19	8000 59289	14	39	8000 61263	7	5
8000 33211	10	41	8000 42023	16	12	8000 48814	19	32	8000 59433	12	19	8000 61269	7	74
8000 33373	12	12	8000 42278	2	21	8000 48916	17	19	8000 59434	12	21	8000 61275	4	18
8000 34002	25	5	8000 42349	18	21	8000 48918	17	35	8000 59801	5	9	8000 61313	19	4
8000 34609	6	40	8000 42781	16	21	8000 49654	22	6	8000 59802	5	7	8000 61313	22	30
8000 35531	12	24	8000 42926	25	27A	8000 50322	3	47	8000 59803	5	8	8000 61313	24	12
8000 35780	8	5	8000 42946	25	6	8000 50569	24	30	8000 59839	16	5	8000 61314	13	63
8000 35781	8	6	8000 42980	10	53	8000 50798	17	3	8000 59939	3	14	8000 61355	13	53
8000 35823	8	35	8000 43391	12	23	8000 50808	25	20	8000 59940	2	36	8000 61362	20	9
8000 36137	14	26	8000 43715	5	4	8000 51957	22A	15	8000 59941	3	35	8000 62651	24	8
8000 36137	14	31	8000 43789	6	5	8000 53155	13	61	8000 59942	2	28	8000 62723	13	78
8000 36467	5	37	8000 43928	12	16	8000 53259	18	32	8000 59965	8	2	8000 62725	2	52
8000 36726	26	9	8000 43928	14	30	8000 53339	2	38	8000 59975	7	3	8000 62725	5	6
8000 36727	25	9	8000 43928	23	18	8000 53340	7	41	8000 59976	7	4	8000 62725	5	26
8000 36786	7	46	8000 44043	10	46	8000 53724	18	19	8000 59977	6	17	8000 62725	5	27
8000 36856	8	53	8000 44240	11	11	8000 54477	8	4	8000 60033	24	26	8000 62725	5	35
8000 36857	8	51	8000 44240	14	33	8000 54692	8	7	8000 60233	13	59	8000 62725	20	18
8000 37299	3	20	8000 44240	15	28	8000 55878	23	15	8000 60234	13	60	8000 62726	5	38
8000 37599	26	16	8000 44240	18	36	8000 55902	18	4	8000 60404	18	34	8000 62726	18	12
8000 37745	20	10	8000 44240	21	15	8000 55903	18	13	8000 60463	8	45	8000 62726	24	14
8000 37891	18	35	8000 44240	25	18	8000 56359	15	27	8000 60464	6	36	8000 62727	2	39
8000 37906	11	16	8000 44240	26	4	8000 56359	22	29	8000 60470	8	55	8000 62727	11	2
8000 38110	7	30	8000 45183	6	19	8000 56359	25	32	8000 60472	7	72	8000 62727	15	24
8000 38210	24	27	8000 45194	2	26	8000 56359	26	29	8000 60472	8	38	8000 62727	18	18
8000 38748	20	13	8000 45194	7	71	8000 56377	18	6	8000 60473	8	37	8000 62727	19	11
8000 38767	16	15	8000 45490	19	5	8000 56381	20	4	8000 60474	7	40	8000 62727	19	14
8000 38799	17	18	8000 45495	5	31	8000 56410	6	31	8000 60475	7	36	8000 62727	19	31
8000 38802	17	38	8000 45495	11	17	8000 56443	13	72	8000 60476	7	6	8000 62727	25	31
8000 38956	16	8	8000 45495	14	35	8000 56443	24	11	8000 60477	7	57	8000 62728	3	18
8000 38957	16	9	8000 45495	26	5	8000 56444	22	34	8000 60479	10	1	8000 62728	5	10
8000 39524	1	11	8000 46881	3	38	8000 56444	25	29	8000 60480	10	11	8000 62728	11	20
8000 40433	20	16	8000 46893	5	33	8000 56806	11	21	8000 60501	10	38	8000 62728	17	9
8000 40449	7	29	8000 46893	5	34	8000 56909	12	33	8000 60504	10	42	8000 62728	17	29
8000 40578	10	12	8000 46893	11	8	8000 57155	18	24	8000 60558	2	33	8000 62728	19	14

DISEGNO DRAWING DESSIN ZEICHNUNG DIBUJO	TAVOLA DRAWING TABLE BILD TABLA	INDEX NO. POS. N. INDICE	DISEGNO DRAWING DESSIN ZEICHNUNG DIBUJO	TAVOLA DRAWING TABLE BILD TABLA	INDEX NO. POS. N. INDICE	DISEGNO DRAWING DESSIN ZEICHNUNG DIBUJO	TAVOLA DRAWING TABLE BILD TABLA	INDEX NO. POS. N. INDICE	DISEGNO DRAWING DESSIN ZEICHNUNG DIBUJO	TAVOLA DRAWING TABLE BILD TABLA	INDEX NO. POS. N. INDICE	DISEGNO DRAWING DESSIN ZEICHNUNG DIBUJO	TAVOLA DRAWING TABLE BILD TABLA	INDEX NO. POS. N. INDICE
8000 62728	19	18	8000 66487	17	32	8000 69111	12	17	8000 72037	24	29	8000 79066	18	30
8000 62728	19	36	8000 66489	17	22	8000 69148	19	15	8000 72092	10	58	8000 79067	22	4
8000 62728	25	8	8000 66551	17	13	8000 69149	19	7	8000 72168	16	14	8000 79068	22	7
8000 62728	26	10	8000 66552	17	33	8000 69150	12	4	8000 72268	15	26	8000 79069	22	3
8000 62729	5	25	8000 66648	20	5	8000 69156	2	29	8000 72289	3	42	8000 79070	22	10
8000 62729	13	40	8000 66651	12	32	8000 69282	13	69	8000 72290	3	43	8000 79071	22	5
8000 62729	19	35	8000 66652	12	26	8000 69282	14	25	8000 72426	6	41	8000 79072	18	31
8000 62729	22	37	8000 66802	1	7	8000 69315	13	57	8000 72427	6	11	8000 79075	18	10
8000 62730	2	40	8000 66807	2	25	8000 69428	24	4	8000 72494	25	4	8000 79077	5	2
8000 62730	3	32	8000 66850	5	12	8000 69429	15	23	8000 72873	14	6	8000 79099	22	8
8000 62730	25	19	8000 67371	14	59	8000 69429	19	21	8000 72874	14	28	8000 79571	25	26
8000 62730	25	36	8000 67372	14	60	8000 69429	19	22	8000 72875	14	27	8000 79754	17	16
8000 62731	3	31	8000 67373	14	11	8000 69429	19	37	8000 72884	14	3	8000 79789	23	28
8000 62731	14	29	8000 67434	10	54	8000 69715	8	1	8000 73140	12	3	8000 80260	13	54
8000 62731	21	13	8000 67440	20	19	8000 69722	8	57	8000 73141	13	58	8000 80277	12	13
8000 62733	13	65	8000 67444	10	52	8000 69723	8	59	8000 73150	3	2	8000 81161	13	11
8000 62795	12	39	8000 67449	5	18	8000 69729	8	50	8000 73394	16	2	8000 81162	13	12
8000 62795	14	8	8000 67457	10	10	8000 69736	8	28	8000 73591	26	7	8000 83395	13	3
8000 62796	12	14	8000 67458	10	47	8000 69737	8	54	8000 73592	26	28	8000 84321	7	65
8000 62796	13	2	8000 67496	21	7	8000 69769	7	1	8000 73834	25	35	8000 84665	12	11
8000 63312	12	20	8000 67610	5	16	8000 69783	11	6	8000 74258	24	25	8000 84702	13	14
8000 63312	14	36	8000 67700	20	20	8000 70215	7	80	8000 74259	24	24	8000 85322	9	7
8000 63424	8	42	8000 67724	12	27	8000 70216	7	81	8000 75166	14	9	8000 85930	13	10
8000 63425	8	9	8000 67744	2	6	8000 70217	7	82	8000 75166	14	40	8000 85932	18	29
8000 63817	2	9	8000 67821	4	22	8000 70277	25	3	8000 75477	24	23	8000 86258	22	42
8000 63821	8	26	8000 67822	4	23	8000 70278	24	19	8000 75584	2	17	8000 86385	13	9
8000 63822	8	56	8000 67824	4	11	8000 70280	25	22A	8000 75672	11	15	8000 86515	22	33
8000 63830	6	22	8000 67970	11	5	8000 70282	25	24A	8000 75673	11	13	8000 86522	22	28
8000 63832	6	22	8000 67997	13	68	8000 70328	13	8	8000 76024	22	1	8000 87058	15	6
8000 64591	14	13	8000 67997	14	12	8000 70637	1	10	8000 76069	5	24	8000 87086	24	2
8000 64726	2	5	8000 68174	7	64	8000 70696	18	5	8000 76338	18	9	8000 87088	24	21
8000 64988	3	39	8000 68191	7	56	8000 71028	3	3	8000 76687	17	15	8000 87119	5	1
8000 65411	14	38	8000 68195	6	10	8000 71230	8	14	8000 76688	17	10	8000 87120	5	3
8000 65412	14	37	8000 68516	13	64	8000 71232	17	20	8000 77373	13	20	8000 87127	5	36
8000 65464	23	28	8000 68584	7	48	8000 71445	18	38	8000 77391	9	3	8000 87153	18	40
8000 65653	6	16	8000 68666	5	15	8000 71445	22	22	8000 77413	16	11	8000 87562	25	22
8000 66101	7	52	8000 68686	7	17	8000 71578	25	47	8000 77478	9	10	8000 87696	25	40
8000 66196	14	2	8000 68710	7	42	8000 71578	26	27	8000 77715	4	21	8000 87839	15	6
8000 66238	20	8	8000 68905	2	19	8000 71624	14	18	8000 77745	18	28	8000 87847	24	7
8000 66395	2	45	8000 68908	2	23	8000 71625	14	18	8000 77884	22A	14	8000 87849	24	3
8000 66427	2	27	8000 69056	12	29	8000 71787	4	12	8000 78326	18	23	8000 87859	5	17
8000 66428	2	7	8000 69056	12	30	8000 71806	22	13	8000 78915	17	31	8000 87906	15	6

DISEGNO DRAWING DESSIN ZEICHNUNG DIBUJO	TAVOLA DRAWING TABLE BILD TABLA	INDEX NO. POS. N. INDICE	DISEGNO DRAWING DESSIN ZEICHNUNG DIBUJO	TAVOLA DRAWING TABLE BILD TABLA	INDEX NO. POS. N. INDICE	DISEGNO DRAWING DESSIN ZEICHNUNG DIBUJO	TAVOLA DRAWING TABLE BILD TABLA	INDEX NO. POS. N. INDICE	DISEGNO DRAWING DESSIN ZEICHNUNG DIBUJO	TAVOLA DRAWING TABLE BILD TABLA	INDEX NO. POS. N. INDICE	DISEGNO DRAWING DESSIN ZEICHNUNG DIBUJO	TAVOLA DRAWING TABLE BILD TABLA	INDEX NO. POS. N. INDICE
8000 87907	15	6	8000 90107	24	19	8000 92961	15	22	8000 94489	14	46	80A0 67248	5	22
8000 88073	4	19	8000 90197	25	22	8000 92965	17	1	8000 94549	27	2	80A0 69551	15	32
8000 88139	25	28	8000 90231	10	8	8000 93049	21	5	8000 94595	25	30	80A0 70558	13	70
8000 88143	12	41	8000 90561	16	23	8000 93051	21	3	8000 94700	23	8	80A0 70581	24	15
8000 88216	15	6	8000 90563	16	1	8000 93052	21	2	8000 94709	22A	6	80A0 73456	14	15
8000 88231	15	21	8000 91236	15	2	8000 93064	14	43	8000 94713	23	5	80A0 74388	14	7
8000 88280	17	14	8000 91238	15	4	8000 93069	1	15	8000 94754	22A	8	80A0 74388	14	22
8000 88334	26	25	8000 91239	15	5	8000 93072	23	21	8000 94757	23	6	80A0 75671	11	9
8000 88335	26	26	8000 91240	15	13	8000 93101	17	23	8000 95263	13	74	80A0 86523	22	27
8000 88336	26	6	8000 91241	15	14	8000 93126	14	1	8000 95269	10	36	80A0 86525	22	26
8000 88337	26	11	8000 91242	15	19	8000 93216	22	16	8000 95331	13	21	80A0 89953	12	6
8000 88338	26	2	8000 91246	15	6	8000 93747	17	5	8000 95341	23	6	80A0 89962	12	7
8000 88386	24	6	8000 91288	1	9	8000 93750	17	8	8000 95411	19	33	80A0 92946	11	1
8000 88873	25	11	8000 91289	1	14	8000 93751	17	2	8000 95412	19	34	80A0 92958	19	9
8000 88887	23	14	8000 91473	13	7	8000 93752	17	21	8000 95599	22	39	80A0 92959	19	10
8000 88889	22A	21	8000 91474	13	13	8000 93753	17	4	8000 95629	22A	11	80A0 95290	27	4
8000 89085	15	7	8000 91475	13	15	8000 93754	17	6	8000 95648	25	27	80A0 95291	27	5
8000 89086	15	8	8000 91476	13	16	8000 93755	17	7	8000 95649	25	24	80A0 95294	27	3
8000 89087	15	9	8000 91477	13	17	8000 93916	21	4	8000 95650	25	48	80B0 43928	12	10
8000 89089	15	11	8000 91478	13	18	8000 93917	21	16	8000 95682	15	1	80B0 43928	12	44
8000 89096	15	15	8000 91479	13	19	8000 94008	9	1	8000 95683	22	11	80B0 66630	20	1
8000 89097	15	16	8000 91480	13	48	8000 94034	25	2	8000 95684	19	3	80B0 75766	2	24
8000 89098	15	17	8000 91497	13	39	8000 94060	22	41	8000 95696	13	66	80B0 84173	3	25
8000 89099	15	18	8000 91506	13	6	8000 94098	20	3	8000 95698	13	50	80B0 84174	3	16
8000 89572	23	26	8000 91519	13	55	8000 94108	15	10	8000 95699	13	49	80C0 05761	10	59
8000 89829	7	78	8000 91607	13	74	8000 94109	15	12	8000 95702	13	4	80C0 24058	10	60
8000 89882	12	9	8000 91608	13	74	8000 94110	15	20	8000 95703	13	1	80C0 53018	17	14
8000 89895	4	10	8000 91609	13	74	8000 94119	25	12	8000 95712	27	6	80C0 60559	9	5
8000 89897	4	9	8000 91610	13	74	8000 94120	25	16	8000 95713	27	7	80C0 69338	13	67
8000 89899	6	35	8000 91611	13	74	8000 94121	25	15	8000 95715	27	1	80C0 69981	13	51
8000 89899	7	12	8000 91743	6	18	8000 94267	19	24	8000 95751	22A	16	80C0 87059	19	3
8000 89908	4	16	8000 92149	26	17	8000 94322	12	31	8000 95751	15	3	80C0 87060	25	25
8000 89910	2	42	8000 92218	17	12	8000 94323	12	37	8000 96571	13	5	80H0 87061	5	19
8000 89919	26	17	8000 92309	17	11	8000 94342	25	37	8000 96643	13	22	80H0 87062	5	20
8000 89920	26	17	8000 92792	22A	23	8000 94354	12	25	8000 96645	13	25	80R0 94242	27	8
8000 90050	2	42	8000 92797	22A	12	8000 94401	21	1	8000 96646	13	25	8A00 01815	12	5
8000 90052	7	60	8000 92797	23	11	8000 94411	22	20	8000 96647	13	41	8A00 07001	19	17
8000 90054	7	23	8000 92920	2	41	8000 94412	22	18	8000 97749	13	77	8A00 15960	2	47
8000 90055	2	46	8000 92931	12	18	8000 94413	22	24	8000 97750	13	76	8A00 15960	2	53
8000 90056	7	79	8000 92939	19	2	8000 94414	22	19	80A0 12032	10	6	8A00 15960	3	34
8000 90057	7	77	8000 92944	7	51	8000 94415	22	38	80A0 66202	14	17	8A00 15960	3	34
8000 90104	22	12	8000 92947	11	7	8000 94488	14	45	80A0 66222	2	50	8A00 18246	25	13
									80A0 67248	5	21	8A00 20373	25	1



DISEGNO DRAWING DESSIN ZEICHNUNG DIBUJO	TAVOLA DRAWING TABLE BILD TABLA	INDEX NO. POS. N. INDICE	DISEGNO DRAWING DESSIN ZEICHNUNG DIBUJO	TAVOLA DRAWING TABLE BILD TABLA	INDEX NO. POS. N. INDICE	DISEGNO DRAWING DESSIN ZEICHNUNG DIBUJO	TAVOLA DRAWING TABLE BILD TABLA	INDEX NO. POS. N. INDICE	DISEGNO DRAWING DESSIN ZEICHNUNG DIBUJO	TAVOLA DRAWING TABLE BILD TABLA	INDEX NO. POS. N. INDICE	DISEGNO DRAWING DESSIN ZEICHNUNG DIBUJO	TAVOLA DRAWING TABLE BILD TABLA	INDEX NO. POS. N. INDICE
8A00 26846	23	20	8A00 72621	23	19	8B00 91498	23	16	8Q00 27910	10	2			
8A00 28182	7	2	8A00 75153	16	3	8C00 24058	10	3						
8A00 28183	4	2	8A00 75153	16	20	8C00 26846	23	20						
8A00 35794	3	5	8A00 75764	7	44	8C00 27690	7	59						
8A00 36022	6	38	8A00 78765	2	31	8C00 28183	4	2						
8A00 37003	7	26	8A00 79072	18	31	8C00 36022	6	38						
8A00 38350	8	52	8A00 86526	22	25	8C00 50322	3	47						
8A00 39651	22A	13	8A00 86938	23	9	8C00 61121	14	20						
8A00 40877	10	51	8A00 88966	8	11	8C00 65442	23	27						
8A00 45395	4	25	8A00 89882	12	42	8C00 67545	19	20						
8A00 48137	8	10	8A00 91498	23	16	8C00 67997	9	11						
8A00 48188	6	1	8A00 92413	23	12	8C00 67997	14	23						
8A00 50322	3	47	8A00 92876	22A	17	8C00 68934	17	34						
8A00 55532	6	2	8A00 92942	19	1	8C00 69112	12	15						
8A00 59964	9	2	8A00 92957	12	1	8C00 69285	16	4						
8A00 60415	2	51	8A00 92968	1	18	8C00 71027	4	17						
8A00 60652	11	19	8A00 92969	1	17	8C00 71759	24	5						
8A00 62644	14	58	8A00 93066	14	42	8C00 72621	23	19						
8A00 62797	12	28	8A00 94060	22	40	8C00 88856	19	12						
8A00 62797	15	30	8A00 94696	22A	10	8C00 91498	23	16						
8A00 62797	16	17	8AA 73426	14	16	8CA0 50798	22	31						
8A00 63644	2	43	8AA0 65340	24	1	8D00 26846	23	10						
8A00 64708	18	1	8AI0 12041	10	4	8D00 28183	4	2						
8A00 65442	23	27	8AL0 12041	10	4	8D00 36022	6	38						
8A00 65503	13	56	8AN0 12041	10	4	8D00 67545	3	30						
8A00 66525	6	44	8AP0 12041	10	4	8D00 70034	25	46						
8A00 66661	14	32	8B00 26846	23	10	8D00 70379	21	10						
8A00 66851	5	14	8B00 36022	6	38	8D00 75042	22A	18						
8A00 67194	7	43	8B00 38110	7	30	8D00 75753	20	21						
8A00 67216	7	55	8B00 38752	20	12	8D00 91498	23	16						
8A00 67545	15	25	8B00 40796	23	17	8E00 30053	8	29						
8A00 67932	10	43	8B00 42029	14	4	8E00 67545	3	26						
8A00 67997	13	52	8B00 42029	16	10	8E00 67545	21	14						
8A00 67997	25	38	8B00 50322	3	47	8E00 69056	12	38						
8A00 68196	6	30	8B00 66525	13	71	8E00 74372	16	6						
8A00 68201	6	28	8B00 66525	24	16	8F00 10789	3	46						
8A00 69138	16	13	8B00 68934	17	34	8F00 28183	4	2						
8A00 69282	14	57	8B00 69429	25	10	8F00 38110	7	30						
8A00 69429	19	23	8B00 70379	21	9	8F00 56515	11	14						
8A00 70266	18	20	8B00 78437	2	30	8GA0 05761	10	5						
8A00 72284	5	32	8B00 82879	22A	3	8H00 28183	4	2						
8A00 72425	6	39	8B00 82879	23	3	8PA0 05761	10	5						