

SPAREPARTSCATALOG

ENGINE

ART.-NR.: 3CM0893310EN

FC 250 2015

ENGINE CASE

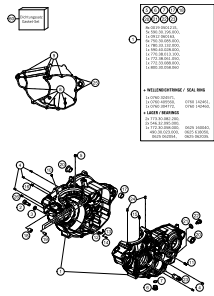

3

CLUTCH COVER

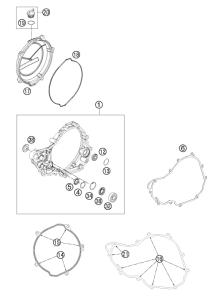

4

CYLINDER

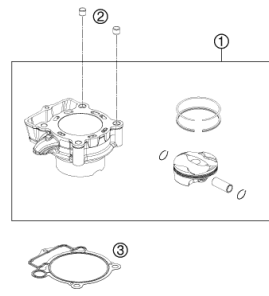

5

CRANKSHAFT, PISTON

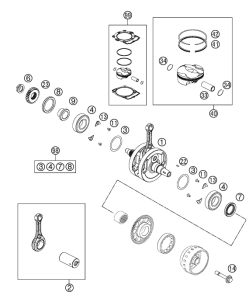

6

CLUTCH

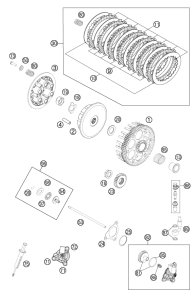

7

TRANSMISSION I - MAIN SHAFT

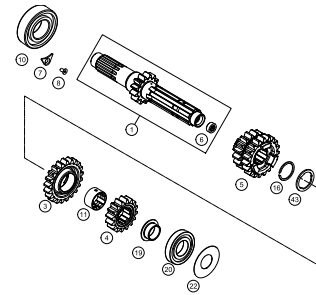

8

TRANSMISSION II - COUNTERSHAFT

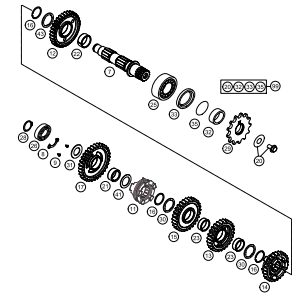

9

SHIFTING MECHANISM

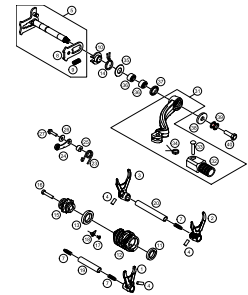

10

COOLING SYSTEM

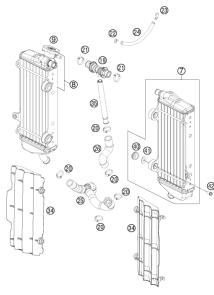

11

VALVE DRIVE

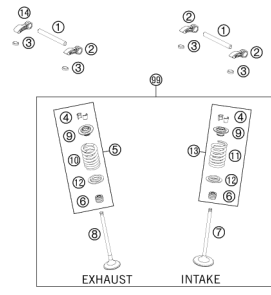

12

TIMING DRIVE

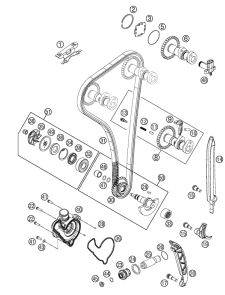

14

CYLINDER HEAD

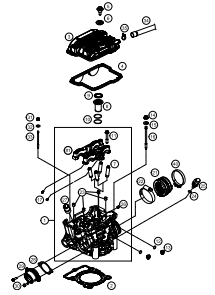

16

LUBRICATING SYSTEM

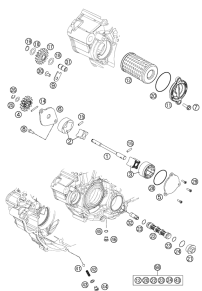

17

IGNITION SYSTEM

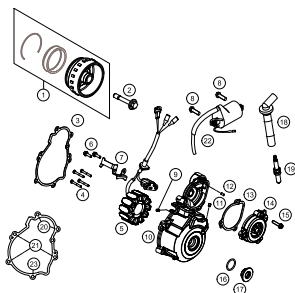

18

ELECTRIC STARTER

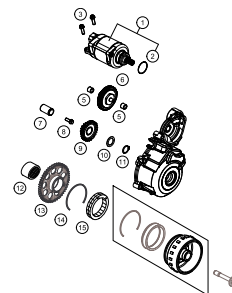

19

THROTTLE BODY

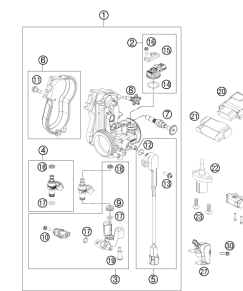

20



All information contained is without obligation. HUSQVARNA MOTORCYCLES GmbH particularly reserves the right to modify any equipment, technical specifications, prices, colors, shapes, materials, services, service work, constructions, equipment and the like so as to adapt them to local conditions or to cancel any of the above items, all without previous announcement and without giving reasons. KTM may stop manufacturing certain models without previous notice. HUSQVARNA MOTORCYCLES shall not be held liable for any deviations of availability and/or ability to deliver, illustrations, descriptions, printing and/or other errors. The illustrated models partly contain extra equipment, which is not applied to standard models.

© by HUSQVARNA MOTORCYCLES GmbH, Mattighofen AUSTRIA; All rights reserved; Reprint, also in extracts, with written allowance of HUSQVARNA MOTORCYCLES GmbH, Mattighofen only.

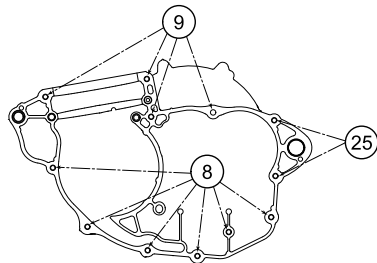
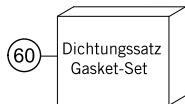

5 6 7 17 18

20 21 22 23

8x 0019 050121S,
5x 590.30.196.000,
1x 0912 060163,
6x 750.30.085.000,
1x 780.33.132.000,
1x 590.40.028.000,
1x 770.38.013.100,
1x 772.38.061.050,
1x 772.33.088.000,
1x 800.30.058.060

1

+ WELLENDICHTRINGE / SEAL RING

1x 0760 324571,
1x 0760 405560, 0760 142461,
1x 0760 304772, 0760 142460,

+ LAGER / BEARINGS

2x 773.30.082.200,
2x 546.32.095.000,
1x 772.30.058.000, 0625 160040,
490.30.023.000, 0625 618050,
0625 062054, 0625 062035.

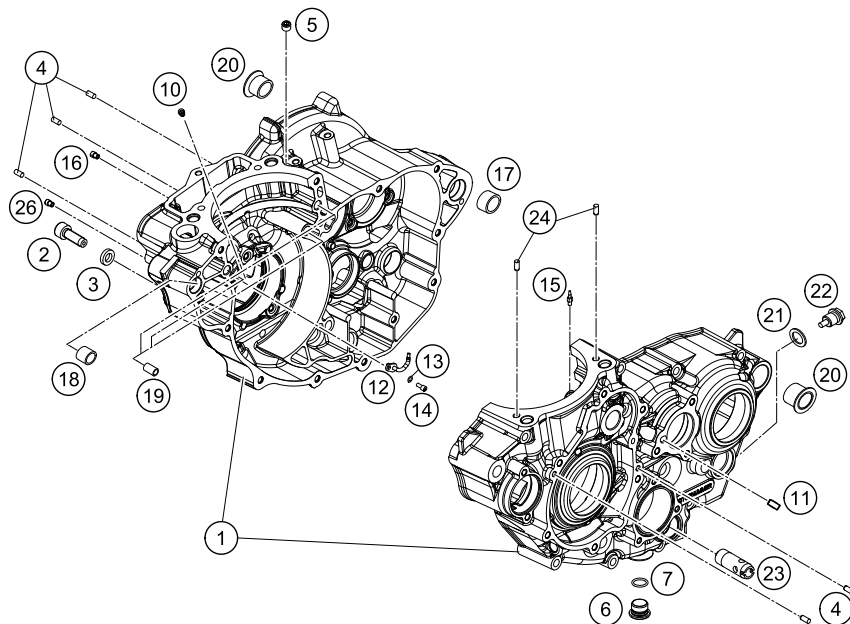

147773010

POS	PARTNUMBER	PARTNAME	PIECE
1	77730100033	ENGINE CASE CPL.	1
2	77730080000	LOCATING SCREW M8 L=25	1
3	58030081000	CU-SEAL RING 8 X 14 X 3	1
4	0402040980	NEEDLE ROL.DIN5402 NRB 4X9,8	5
5	0906100100	PLUG DIN0906-M10X1	2
6	78036081000	HOLDING BOLT M14X1,5	1
7	0770110015	O-RING 1,5x11 SILICON	1
8	0025060556	HH COLLAR SCREW M6X55 TX30	6
9	0025060656	HH COLLAR SCREW M6X65 TX30	4
10	80030058060	OIL JET "60" M4	1
11	77230066000	THROTTLE M5X10X0,5	1
12	81230164050	OIL JET ANGLED 50	1
13	0770035020	O-RING 3,5X2,00 NBR	1
14	0912040103	AH.SCREW DIN0912-M 4X10	1
15	60030063050	OIL JET 50 05	1
16	59030058000	JET 100 BING(44-031/180) M4	1
17	59030024000	DOWEL 17 X 19 X 12	1
18	54630027000	DOWEL BUSHING 13,8X11X12	1
19	59030023000	DOWEL 6X8X11,5	3
20	75030010100	CASE BUSH	2
21	58038022000	CU-SEAL RING DIN7603-12X18X1,5	1
22	58030021000	OILDRAIN PLUG W.MAG. M 12X1,5	1
23	77038022000	OIL INTAKEPIPE	1
24	0402050080	CYLINDER ROLLER ZRO 5X8	2
25	0025060856	HH COLLAR SCREW M6X85 TX30	2
26	77030058150	JET 44-031/150	1
60	77730099000	GASKET SET 250 SX-F	1

C147773011

* NEW PART

X ON DEMAND

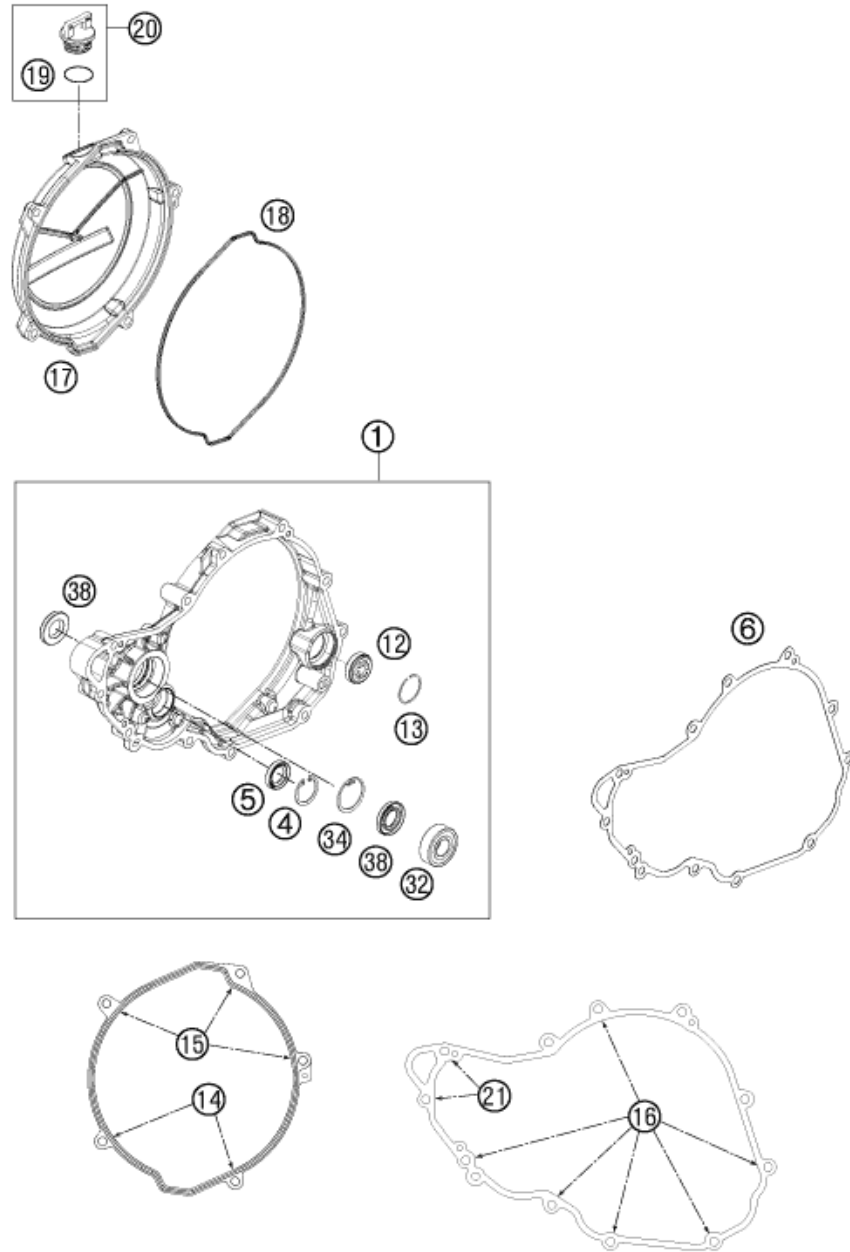

POS	PARTNUMBER	PARTNAME	PIECE
1	77730001144	CLUTCH COVER CPL.	1
4	0472024120	CIRCLIP DIN0472-24X1.2	1
5	0760142450	SHAFT SEAL RING 14X24X5 VITON	1
6	77730025000	CLUTCH COVER GASKET	1
12	59030019100	OIL LEVEL GLASS	1
13	61030019050	CIRCLIP OIL LEVEL GLASS 03	1
14	0025060206	HH COLLAR SCREW M6X20 TX30	2
15	0025060456	HH COLLAR SCREW M6X45 TX30	3
16	0025060256	HH COLLAR SCREW M6X25 TX30	8
17	77230626000KA	OUTER CLUTCH COVER "HQV"	1
18	77230027000	GASKET FOR OUTER CLUTCH COVER	1
19	0770191015	O-RING 19,00X3,00 NBR	1
20	58030120000	OIL FILLER CAP M24x3 WITH O-R	1
21	0025060406	HH COLLAR SCREW M6X40 TX30	2
32	0625062022	BALL BEARING 6202 C0 2	1
34	0472300120	CIRCLIP 30X1,2	1
38	07601530451	SHAFT SEAL RING 15X30X4.5 BAUD	2

137783020

C147773022

* NEW PART

X ON DEMAND

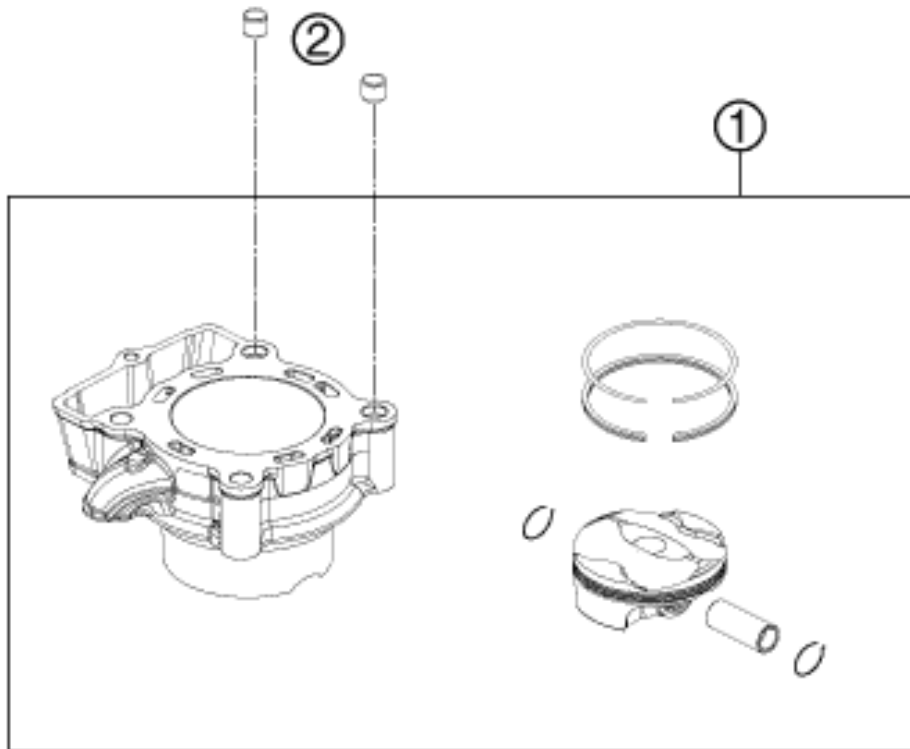

POS	PARTNUMBER	PARTNAME	PIECE
1	77730038000	CYLINDER AND PISTON	1
2	58530014100	DOWEL BUSHING 10,2X12,5X10	2
3	77230035000	CYLINDER BASE GASKET	1

137773040

C147773041

* NEW PART

X ON DEMAND

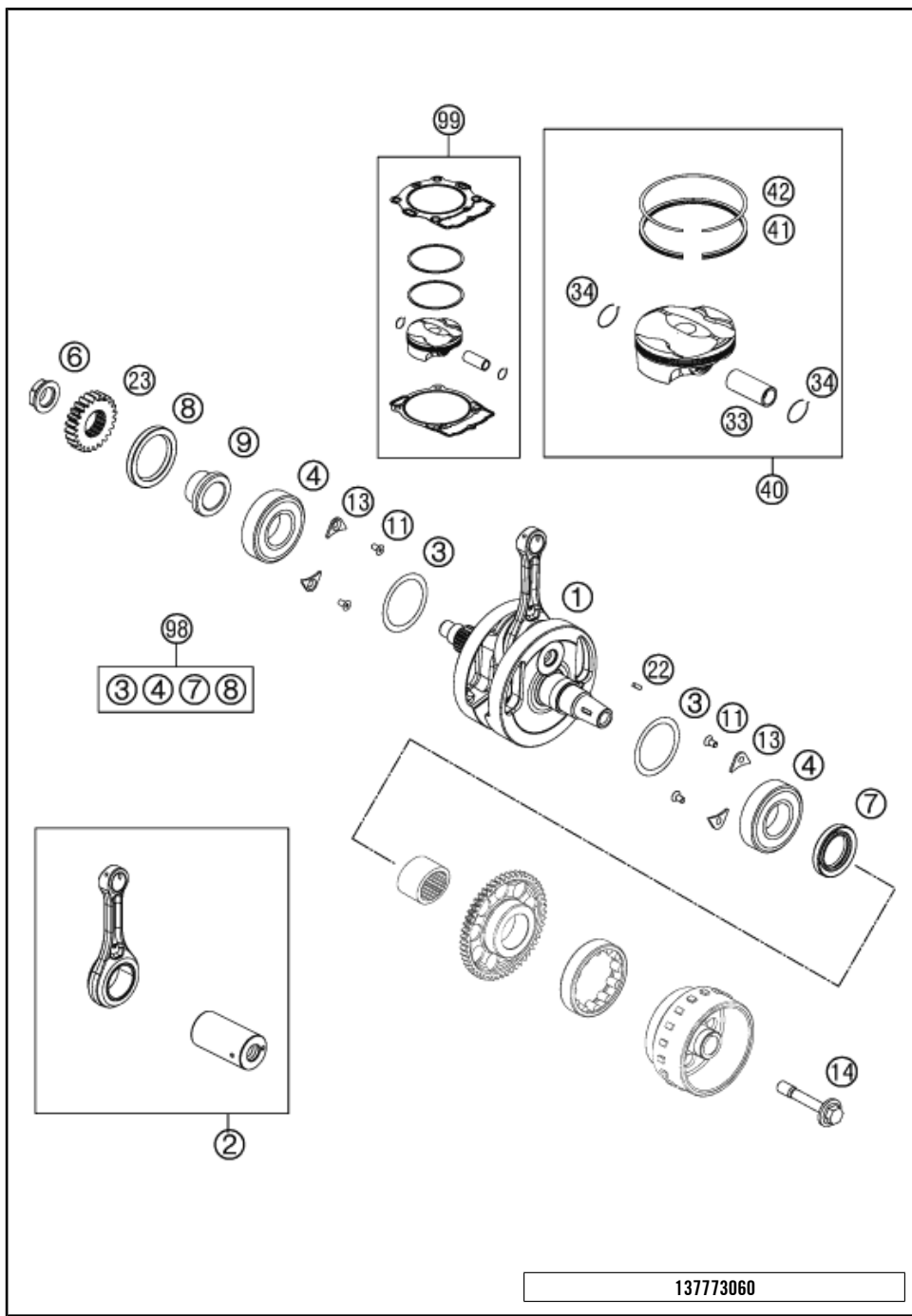

POS	PARTNUMBER	PARTNAME	PIECE
1	77730018100	CRANKSHAFT CPL.	1
2	77730015144	CONNECTING ROD REPAIR SET	1
3	0988324510	THRUST WASHER 988ST 32X0,1	x
3	0988324515	THRUST WASHER 988ST 32X0,15	x
3	0988324530	THRUST WASHER 988ST 32X0,30	x
4	77330082200	BEARING NJ 206 ECP/HN3C4HVA624	2
6	77230029000	NUT PRIMARY WHEEL	1
7	0760304772	SH.SEAL RING 30X47X7 BSL VITON	1
8	0760405560	SHAFT SEAL RING A40x55x6 VITON	1
9	77232022000	SPACER BUSHING PRIMARY GEAR	1
11	0019050106S	INT. TORX FLAT HEAD M5X10 10.9	4
13	75030085000	RETAINING PLATE F. CS BEARING	4
14	77339010100	FLYWHEEL SCREW	1
22	0888030037	WOODRUFF KEY DIN6888-3X3,7	1
23	77232023024	PRIMARY GEAR 24T.	1
33	77730033200	PISTON PIN	1
34	77730074000	CIRCLIP 16X1.4 MM	2
40	77730007100 I	PISTON I CPL. 250	x
40	77730007100 II	PISTON II CPL. 250	x
41	77730032000	SCRAPER RING 250	1
42	77730030000	COMPRESSIONRING 250	1
98	00050002311	CRANKSHAFT REP. KIT SX-F 13-15	x
99	00050000222	PISTON KIT GR.I 250 SX-F13-14	x
99	00050000223	PISTON KIT GR.II 250 SX-F 13	x

13773060

C14773061

* NEW PART X ON DEMAND

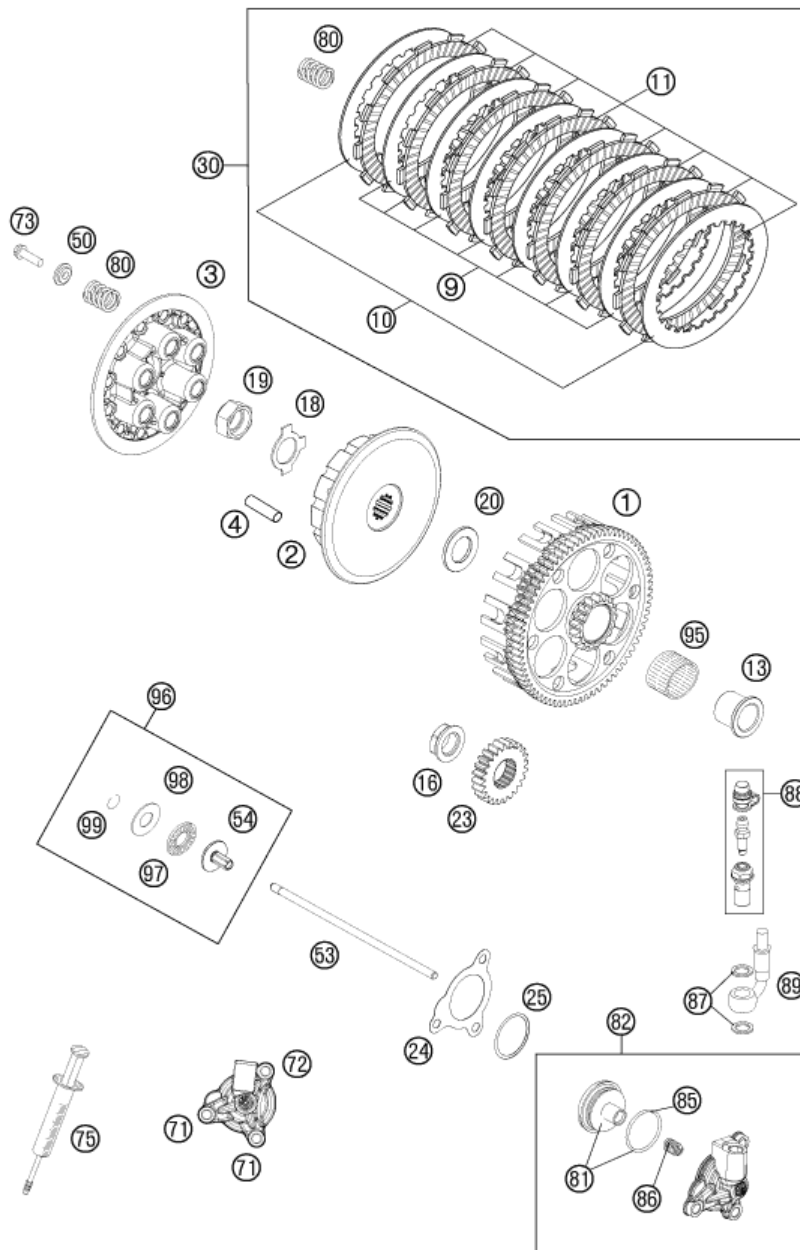

POS	PARTNUMBER	PARTNAME	PIECE
1*	77232001173	OUTER CLUTCH HUB	1
2	77232002000	INNER CLUTCH HUB	1
3	77232003000	PRESSURE PLATE	1
4	77232004000	DRIVING SLEEVE D=7,95 L=38	12
9	59032010200	INTERMEDIATE DISC 1,4MM 2002	7
10	59032010100	INTERMEDIATE DISC 1MM 2002	2
11	59032011100	LINING DISC 2MM 04	8
13	77232015000	INNER RING	1
16	77230029000	NUT PRIMARY WHEEL	1
18	77232018000	SHEET METAL LOCK	1
19	77232019000	HEXAGON NUT M18X1,5	1
20	77232009100	WASHER 21,8 X 37 X 3	1
23	77232023024	PRIMARY GEAR 24T.	1
24	77232062000	GASKET F. OUTPUT CYLINDER	1
25	0770300015	O-RING 30,00X1,50 NBR 70	1
30	78132010010	CLUTCH KIT 350 SX-F 11-15	1
50	59032006000	SPRING RETAINER 6,2X12X18X3,6	6
53	77232054000	PUSH ROD	1
54	78032057000	PRESSURE PIECE	1
71	0025060166	HH COLLAR SCREW M6X16 TX30	2
72	0025060356	HH COLLAR SCREW M6X35 TX30	1
73	0025060256	HH COLLAR SCREW M6X25 TX30	6
75	50329050000	VENT INJEKTION HYDR. CLUTCH	1
80	52332005000	CLUTCH SPRING 2,4X40 200'98	6
81	77232066000	PISTON CPL.	1
82	77232061044	OUTPUT CYLINDER CPL.	1
85	54832067000	O-RING	1
86	54832069000	PRESSURE SPRING	1
87	42013226000	CU-SEAL RING DIN7603-10X16X1	2
88	62513020000	BLEEDER SCREW CPL. 05	1
89	54832063000	CLUTCH PIPE 06	1
95	56532095000	NEEDLE BEARING K26X30X22ZW.KSE	1
96	78032057044	PRESSURE PIECE CPL. 08	1
97	54637097200	AXIAL NEEDLE BEARING AXK 1226	1
98	54637098200	AXIAL WASHER AS1226 12X26X1	1
99	0993012000	CIRCLIP DIN7993-RW12	1

117723210

C157773210

* NEW PART X ON DEMAND

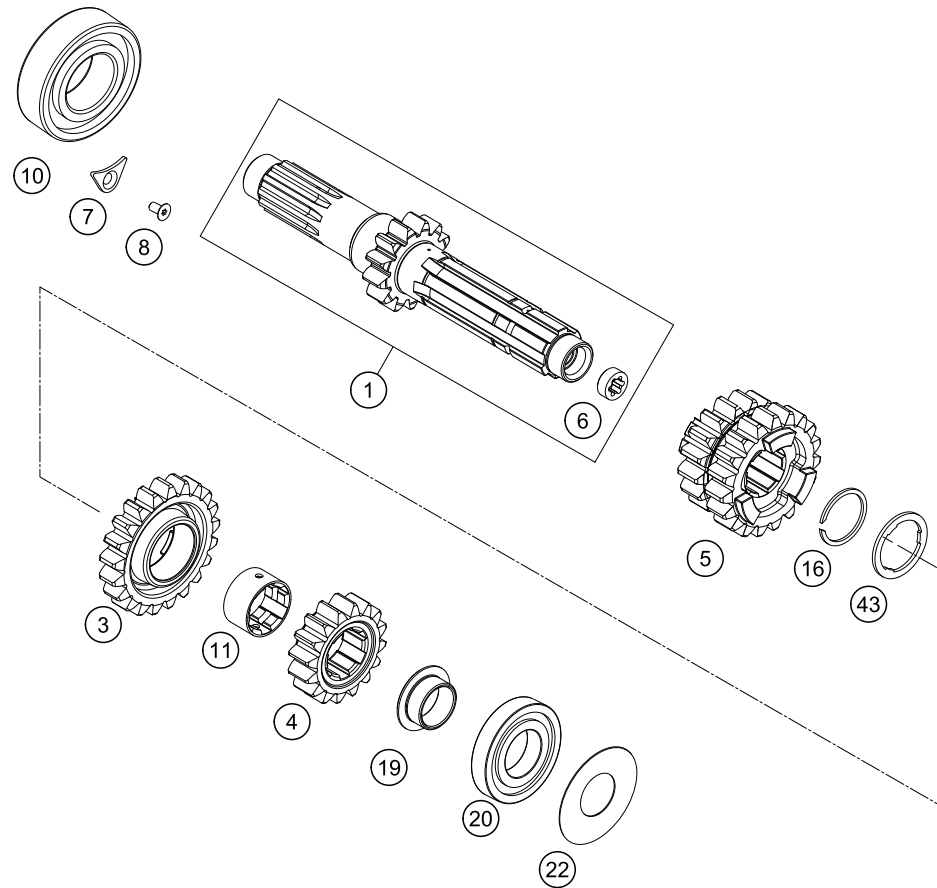

POS	PARTNUMBER	PARTNAME	PIECE
1	77733301000	MAIN SHAFT CPL. 13T.	1
3	77733005000	IDLER GEAR 5TH G. T=21	1
4	77733002000	SOLID GEAR 2ND G. T=16	1
5	77733303000	SLIDING GEAR 3./4.G Z=17/19	1
6	78033001110	BUSHING	1
7	75030085000	RETAINING PLATE F. CS BEARING	1
8	0019050106S	INT. TORX FLAT HEAD M5X10 10.9	1
10	0625062054	BALL BEARING 6205 C3 NTN	1
11	77733024000	IDLER GEAR BUSHING	1
16	50133090000	LOCK RING 22X1,2	1
19	77733027000	BUSHING	1
20	0625160040	GROOVED BALL BEAR. TM 16004 C3	1
22	77233088000	SPACER SHIM 21X42X0.2	1
43	77733021000	STOP DISC	1

147773330

C147773332

* NEW PART

X ON DEMAND

TRANSMISSION II - COUNTERSHAFT

FC 250 2015

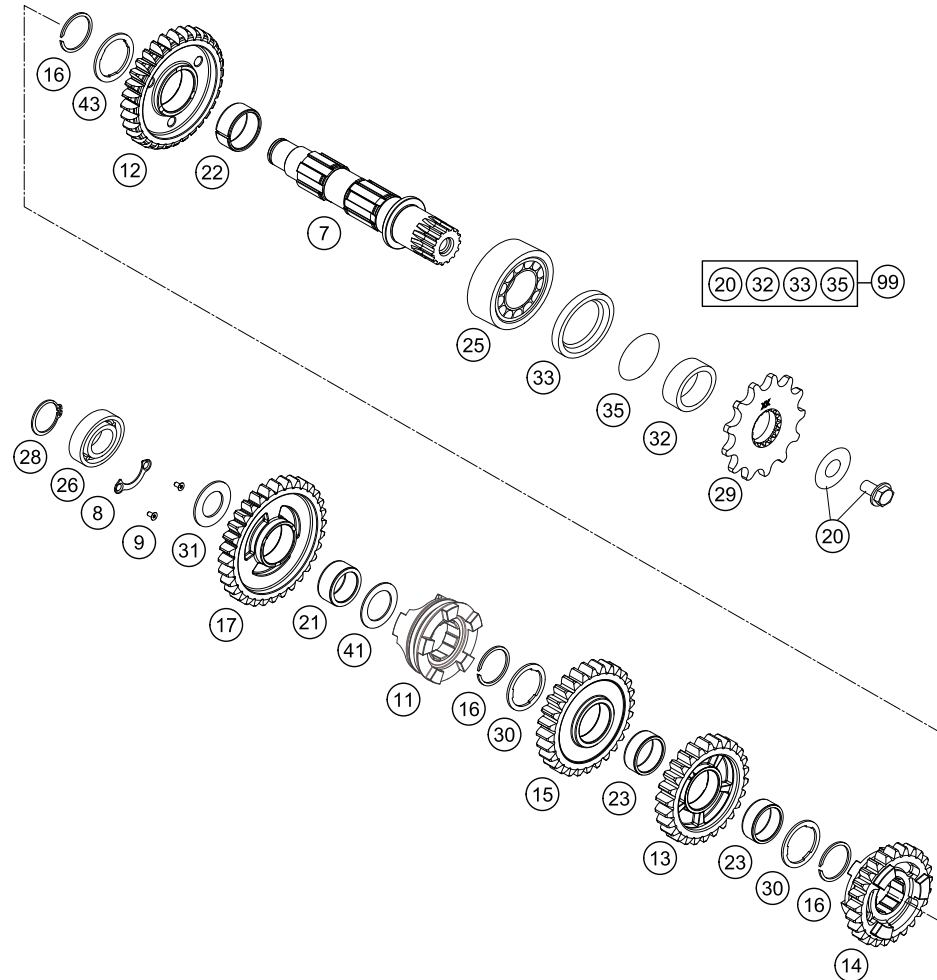

POS	PARTNUMBER	PARTNAME	PIECE
7	77733110000	COUNTERSHAFT	1
8	78033132000	TAB WASHER BEARING COUNT.SHAFT	1
9	0019050106S	INT. TORX FLAT HEAD M5X10 10.9	2
11	77733316000	SHIFT COLLAR	1
12	77733012000	IDLER GEAR 2ND G. T=32	1
13	77733214000	IDLER GEAR 4.G. Z=26	1
14	77733215000	SLIDING GEAR 5.G.,Z=25	1
15	77733213000	IDLER GEAR 3.G. Z=28	1
16	0417024000	CIRCLIP WS24	3
17	77733011000	IDLER GEAR 1ST G. T=32	1
20	59033034044	SCREW 10.9+SPRING WASHER	1
21	0405202612	NEEDLE BEARING K 20X26X12	1
22	0405242812	NEEDLE BEAR. K24X28X11,9 DIV.	1
23	0405222611	NEEDLE BEAR.K 22X26X10 DIVIDED	2
25	49030023000	CYL.ROLL BEARING NJ205	1
26	0625062035	BALL BEARING 6203 JR2 C3	1
28	0471170015	CIRCLIP DIN 0471-17X1, 5	1
29	50033029013	FRONT SPROCKET 13-T	1
29	50033029014	FRONT SPROCKET 14-T	x
30	77733043000	STOP DISC 23,4X31X1,5	2
31	77233020000	STOP DISK 17,2X30X1,3	1
32	54633014100	SPACER BUSHING 12MM	1
33	0760324571	SHAFT SEAL RING 32X45X7 BSLNBR	1
35	0770020220	O-RING 25,12X1,78 NBR70	1
41	54833080000	STOP DISC 20,2X30X1	1
43	77733044000	STOP DISC 24X32X1,5	1
99	00050000941	COUNTER SHAFT REP.KIT 4 STROKE	x

147773360

C147773362

* NEW PART

X ON DEMAND

SHIFTING MECHANISM

FC 250 2015

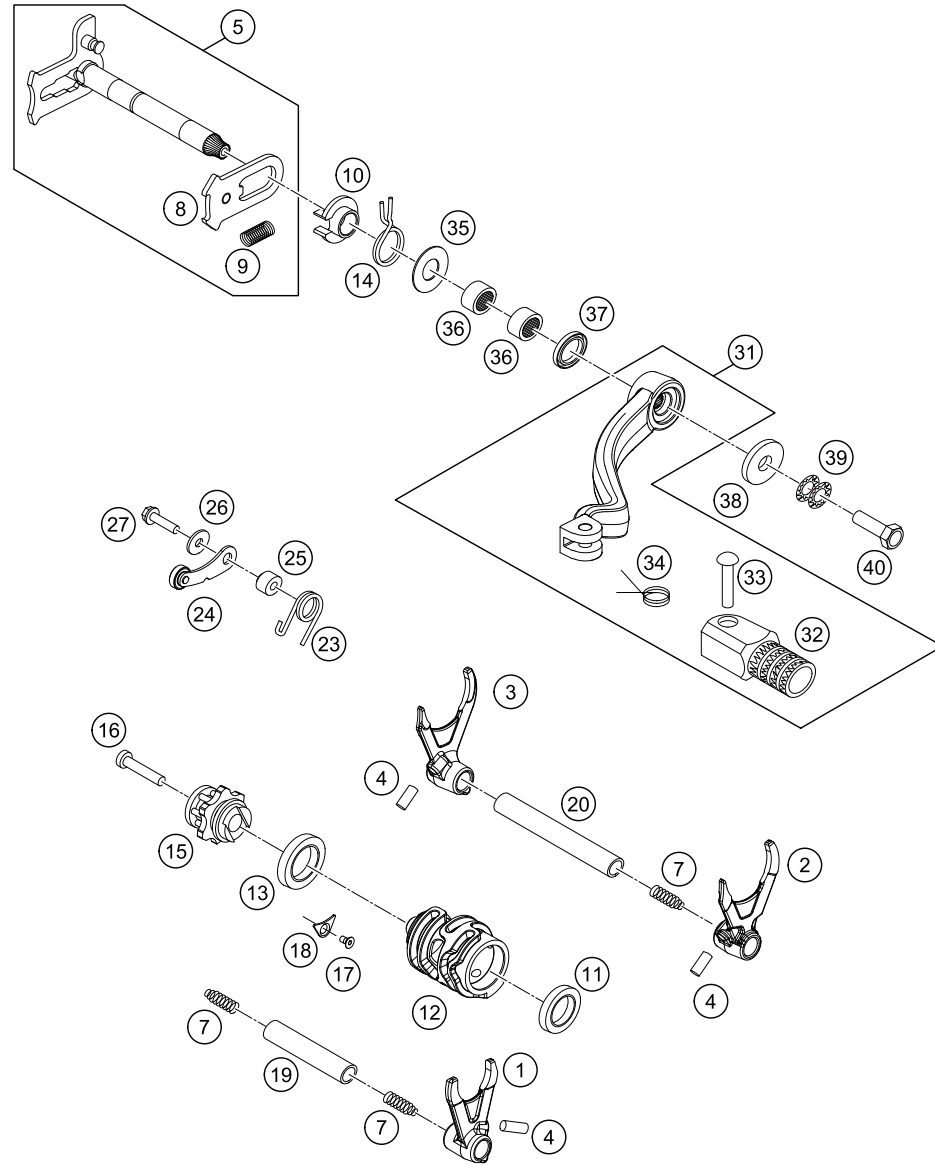

POS	PARTNUMBER	PARTNAME	PIECE
1	77734001000	SHIFTING FORK 5TH/6TH GEAR	1
2	54834202000	SHIFT FORK 2./4.G.	1
3	54834203000	SHIFT FORK 1./3. G.	1
4	0402061480	NEEDLE ROLLER DIN5402 6X14,8	3
5	54834005144	SHIFT SHAFT CPL.	1
7	58038023200	PRESSURE SPRING 0,9MM	3
8	54634008044	% SLIDING PLATE CPL.	1
9	56534013100	TENSIONING SPRING 0,8MM	1
10	54634020000	SPRING GUIDE	1
11*	0625069030	% GOOVED BALL BEAR. 6903 JR C4	1
12*	77734112100	SHIFT ROLLER 5G	1
13	0625618050	BALL BEARING 61805 C3	1
14	54834014000	RETURN SPRING 03	1
15	77234015000	SHIFT LOCATING DRUM CPL.	1
16	0912060353	AH SCREW DIN0912-M 6X35	1
17	0019050106S	INT. TORX FLAT HEAD M5X10 10.9	1
18	75030085000	RETAINING PLATE F. CS BEARING	1
19	54834019000	SHIFT. RAIL MAIN SHAFT 250/300	1
20	54834020000	SHIFT. RAIL C. SHAFT 250/300	1
23	60034023000	ARRESTING LEVER SPRING 03	1
24	50334024144	LOCATING LEVER CPL. 08	1
25	54634052300	SLEEVE FOR LOCKING LEVER	1
26	0021050003	WASHER DIN9021-A 5,3	1
27	0025050206	HH COLLAR SCREW M5X20 TX30	1
31	54734031000	SHIFT LEVER CPL. 2-STROKE 2001	1
32	54634131000	STEP PLATE FOR SHIFT LEVER 250	1
33	54634031050	BOLT 6X25 FOR SHIFT LEVER	1
34	54634032100	SHIFTING LEVER SPRING 250	1
35	54634050000	STOP DISK 14X30X1	1
36	54632095000	NEEDLE BEAR.HK 1412 14X20X12	2
37	0760142460	SHAFT SEAL RING 14X24X6 B	1
38	50232050001	STEEL WASHER 6,4X17X3	1
39	50233041000	PAIR OF WASHERS M 6 NORDLOCK	1
40*	0025060166S	HH COLLAR SCREW M6X16 ISA 30	1

147773410

C157773411

* NEW PART

X ON DEMAND

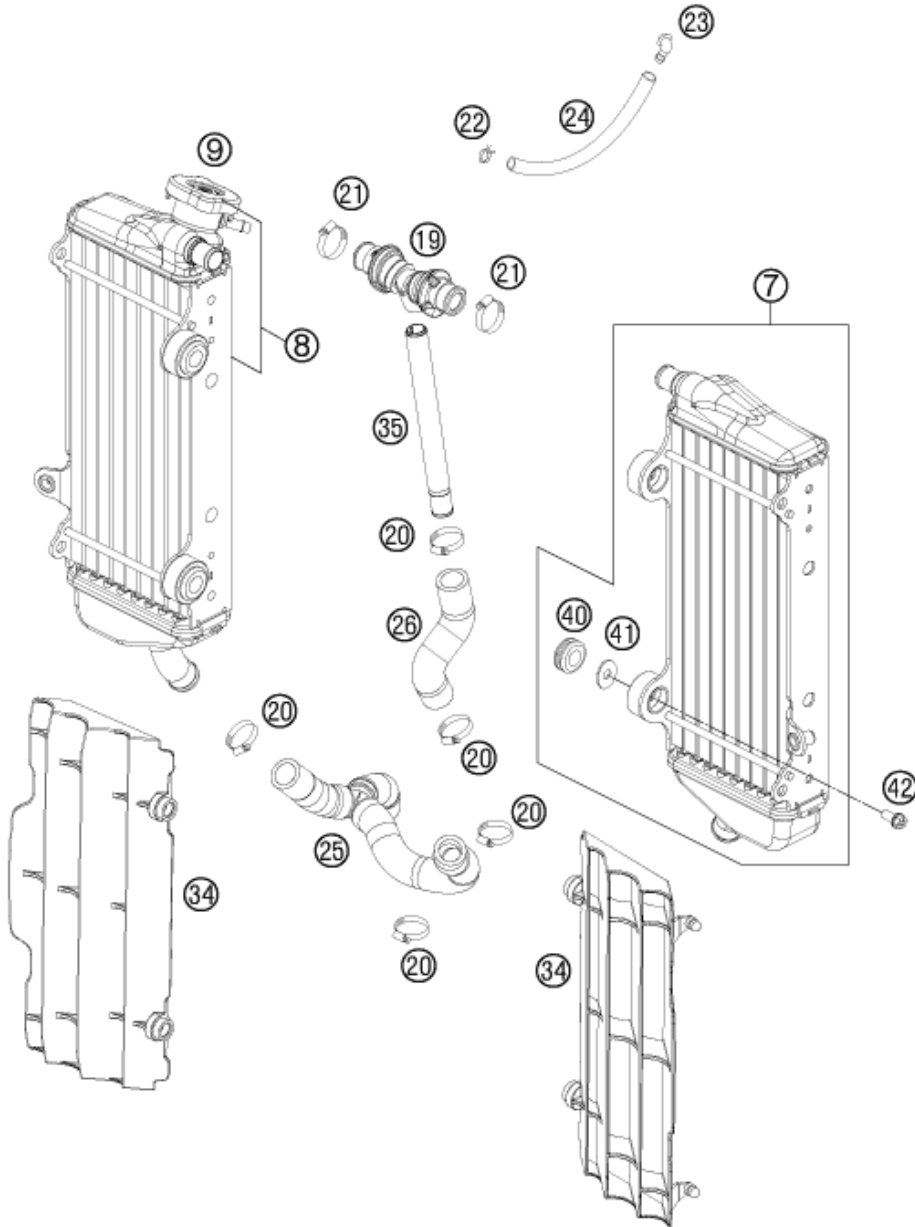

POS	PARTNUMBER	PARTNAME	PIECE
7	77035007300	% RADIATOR L/S "55623U" 12	1
8	77235008100	% RADIATOR R/S "55637U" 13	1
9	77335016000	RADIATOR CAP SMALL 1,8 BAR	1
19	77235071044	Y-CONNECTOR CPL.	1
20	10001020000	HOSE CLAMP GEMI 18-29	5
21	42013037400	HOSE CLAMP NORMA 14/24	2
22	59007017000	CLAMP YDNAC 10096F (9,6MM)	1
23	50303089000	ANGLE PIECE '97	1
24	50335030001	PVC-HOSE 6X9	x
25	77235025033	RADIATOR HOSE CPL.+Y-CONNECT.	1
26	77235024000	PREFORMED HOSE ENG. Y-CONNECT.	1
34	7733503400030	RADIATOR PROTECTION BLACK 07	x
35	77235073000	HOSE CONNECTOR L=172,5	1
40	41001052000	RUBBER SLEEVE D=12MM	4
41	77335001000	WASHER FOR RADIATOR 08	4
42	0023060123	COLLAR SCREW M6X12 TX	4

127723530

C147773532

* NEW PART

X ON DEMAND

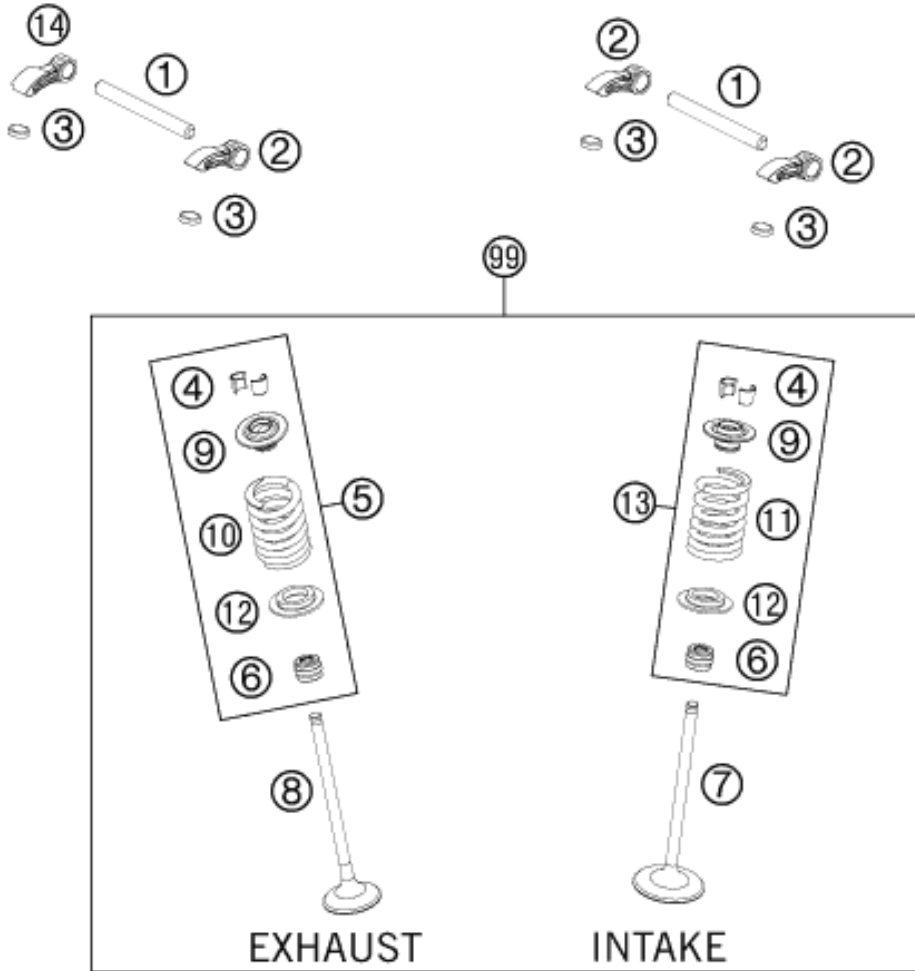

POS	PARTNUMBER	PARTNAME	PIECE
1	77236056000	VALVE LEVER SHAFT	2
2	77236060000	VALVE LEVER	3
3	77036035172	SHIM D=8,9/1,72	X
3	77036035176	SHIM D=8,9/1,76	X
3	77036035180	SHIM D=8,9/1,80	X
3	77036035184	SHIM D=8,9/1,84	X
3	77036035188	SHIM D=8,9/1,88	X
3	77036035192	SHIM D=8,9/1,92	X
3	77036035196	SHIM D=8,9/1,96	X
3	77036035200	SHIM D=8,9/2,00	X
3	77036035204	SHIM D=8,9/2,04	X
3	77036035208	SHIM D=8,9/2,08	X
3	77036035212	SHIM D=8,9/2,12	X
3	77036035216	SHIM D=8,9/2,16	X
3	77036035220	SHIM D=8,9/2,20	X
3	77036035224	SHIM D=8,9/2,24	X
3	77036035228	SHIM D=8,9/2,28	X
3	77036035232	SHIM D=8,9/2,32	X
3	77036035236	SHIM D=8,9/2,36	X
3	77036035240	SHIM D=8,9/2,40	X
3	77036035244	SHIM D=8,9/2,44	X
3	77036035248	SHIM D=8,9/2,48	X
3	77036035252	SHIM D=8,9/2,52	X
3	77036035256	SHIM D=8,9/2,56	X
3	77036035260	SHIM D=8,9/2,60	X
4	77036033000	VALVE COLLET 05	8
5	77736128144	VALVE SPRING KIT EXHAUST	1
6	77036027000	VALVE-STEM SEALING 05	4
7	77736030000	INTAKE VALVE	2
8	77736031000	EXHAUST VALVE	2
9	77736032000	VALVE SPRING PLATE	4
10	77736028100	VALVE SPRING NHK HUB 11MM AL YELLOW / ORANGE	2
11	77736028200	VALVE SPRING NHK HUB 11MM EL GREEN	2
12	77736036000	VALVE SPRING HOLDER	4
13	77736128044	VALVE SPRING KIT INTAKE	1

137773610

C147773611

* NEW PART

X ON DEMAND

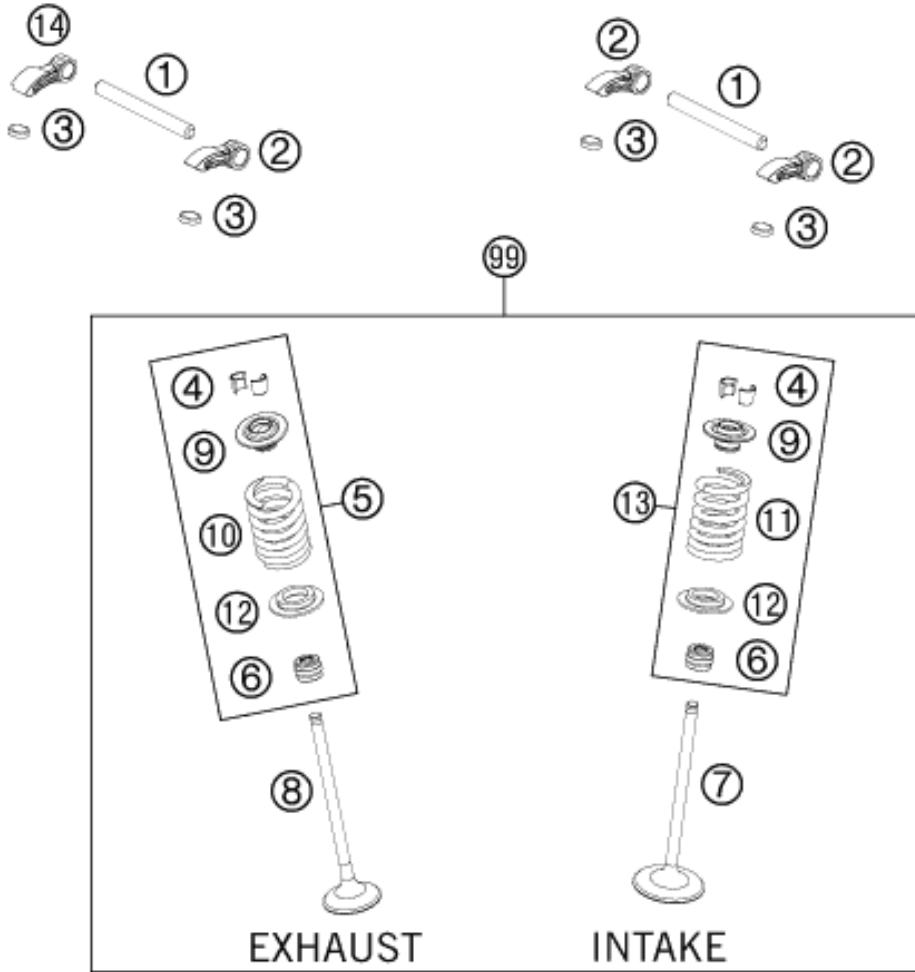

POS	PARTNUMBER	PARTNAME	PIECE
14	77736060000	VALVE LEVER	1
99	77736030010	VALVE KIT 250 SX-F 13-15	1

137773610

C147773611

* NEW PART

X ON DEMAND

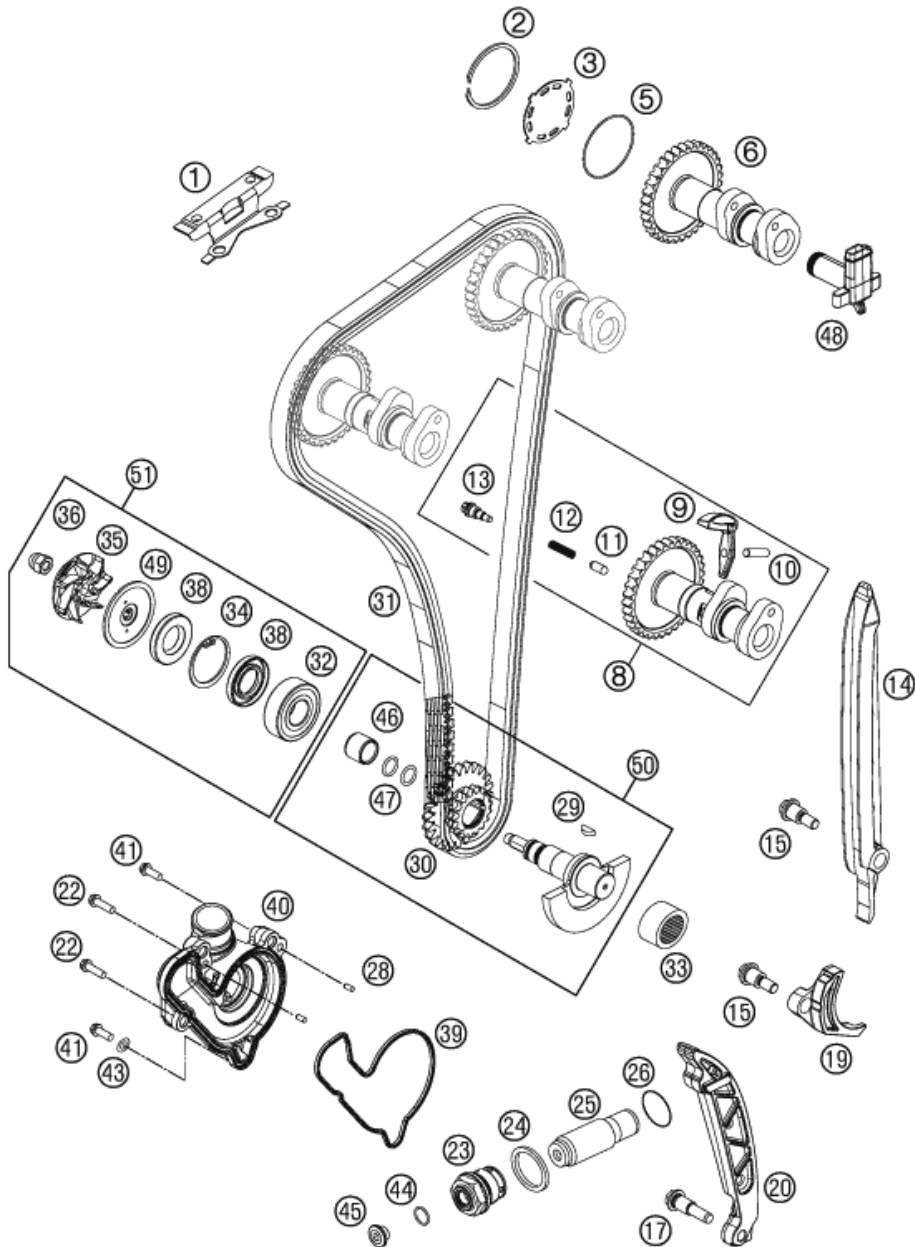

137773620

POS	PARTNUMBER	PARTNAME	PIECE
1	77736004000	% TIMING CHAIN GUIDE TOP	1
2	0472042150	COPPER WASHER SB42	1
3	77736082000	BREATHER PLATE	1
5	0770400010	O-RING 40,00X1,00 VITON	1
6	77736009000	CAMSHAFT INTAKE	1
8	77736010044	CAMSHAFT EXHAUST CPL.	1
9	77736016000	DECOMPRESSION LEVER CPL.	1
10	0402051880	NEEDLE ROLLER NRB 5X18,8 G2	1
11	77336016055	DECO SPRING PIN L=10,6 07	1
12	77336017030	SPRING FOR AUTO DECOMPR.	1
13	77336017050	DECO SCREW PLUG	1
14	77236001000	TIMING CHAIN GUIDE	1
15	77236001160	BUSHING SCREW M6	2
17	77236002160	BUSHING SCREW M8	1
19	77236005000	SECURING PROTECTION	1
20	77236002000	TENSIONING RAIL	1
22	0025060406	HH COLLAR SCREW M6X40 TX30	2
23	77336008000	HOLDING BOLT M24X1,5	1
24	0603242920	CU SEAL-RING DIN7603 A24X29X2	1
25	77036003000	CHAIN ADJUSTER HYD. 05	1
26	0770180020	O-RING 18,00X2,00 NBR 70	1
28	0402040980	NEEDLE ROL.DIN5402 NRB 4X9,8	2
29	0888030037	WOODRUFF KEY DIN6888-3X3,7	1
30	77236076000	TIMING VALVE TWIN WHEEL	1
31	77236013000	TIMING CHAIN	1
32	0625062022	BALL BEARING 6202 C0 2	1
33	77230058000	NEEDLE BEARING NK16/16	1
34	0472300120	CIRCLIP 30X1,2	1
35	81235055020	WATER PUMP ROTOR	1
36	61230045000	CAP NUT M6 STAINLESS STEEL	1
38	07601530451	SHAFT SEAL RING 15X30X4.5 BAUD	2
39	77735053000	WATER PUMP COVER GASKET	1
40	77735052000	WATERPUMP COVER	1
41	0025060256	HH COLLAR SCREW M6X25 TX30	2
43	0603061001	CU-SEAL RING DIN7603-6X10X1	1
44	0770010010	O-RING 10,00X1,00 NBR 70 SH	1
45	77236080000	SCREW PLUG	1
46	77236072020	WEAR BUSHING WAPU	1

C147773624

* NEW PART

X ON DEMAND

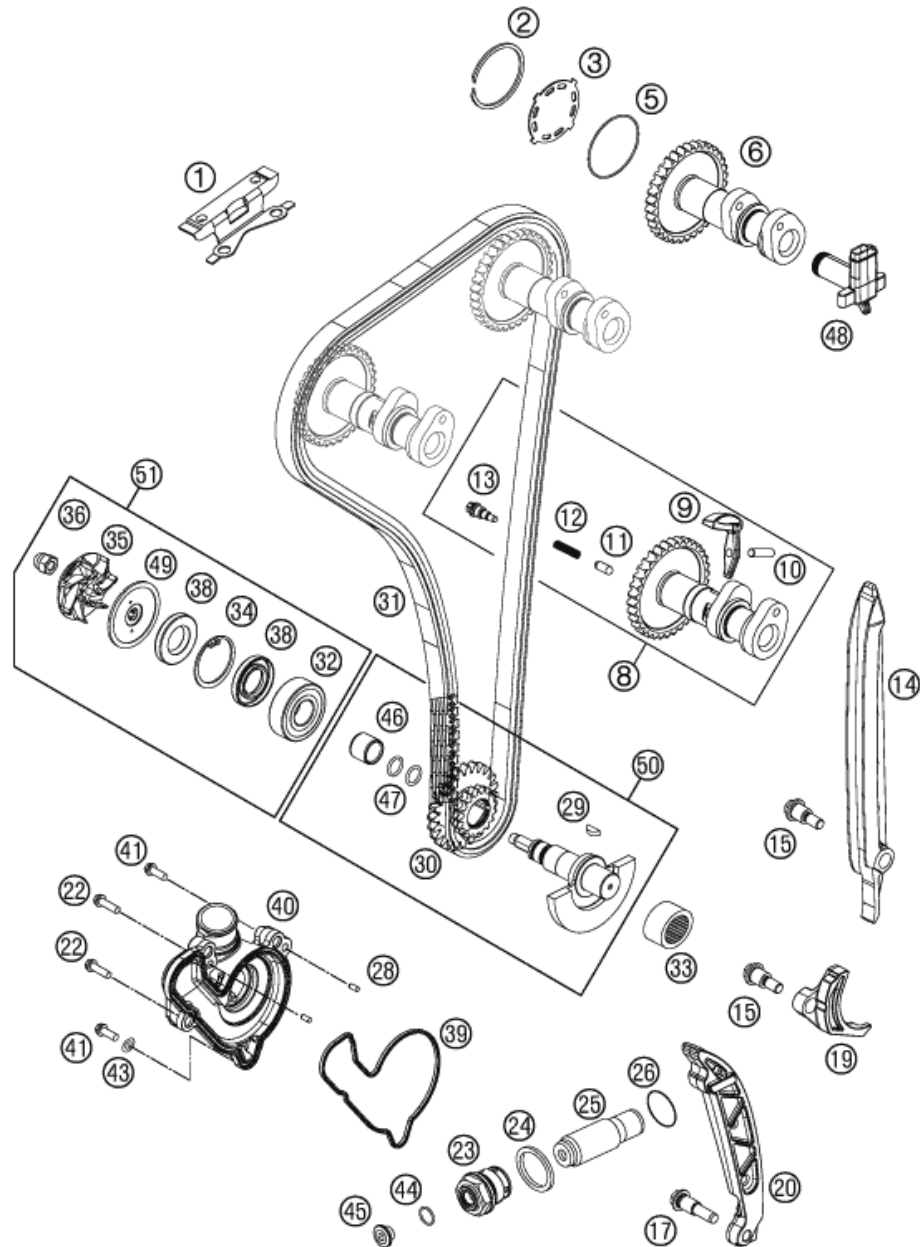

POS	PARTNUMBER	PARTNAME	PIECE
47	07700900151	O-RING 9x1,5 V80 SH	2
48	77236081000	ANGLE PIECE F. BREATHER SYSTEM	1
49	81235055110	DISC WATER PUMP	1
50	77536072033	BALANCER SHAFT CPL.	1
51	77235055010	WATER PUMP REP. KIT 11-14	x

137773620

C147773624

* NEW PART

X ON DEMAND

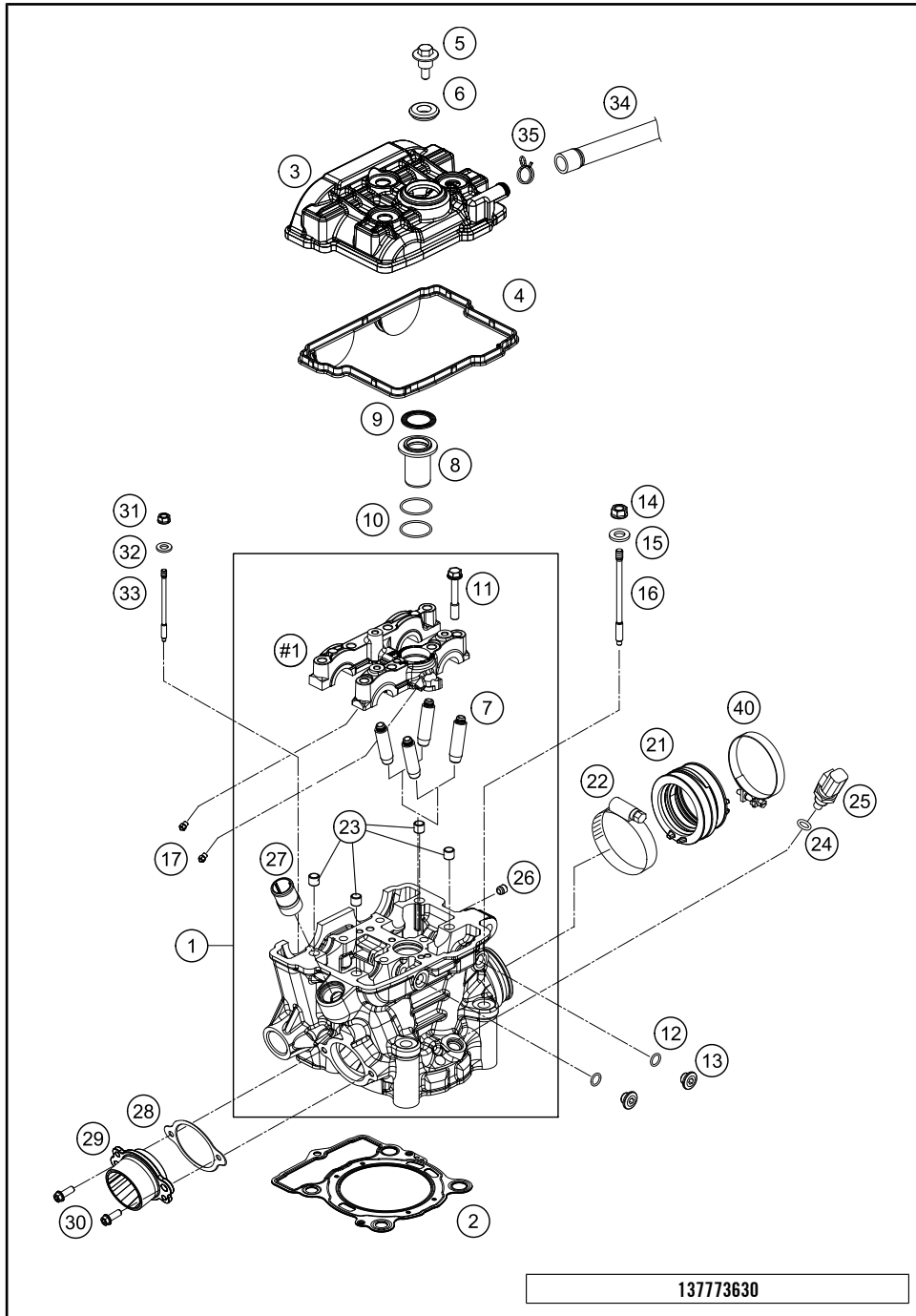

POS	PARTNUMBER	PARTNAME	PIECE
1	77736020044	CYLINDER HEAD CPL.	1
2	77730036085	CYLINDER HEAD GASKET	1
3	77736052000DA	VALVE COVER	1
4	77736053000	VALVE COVER GASKET	1
5	77336054150	VALVE COVER SCREW	3
6	77036054050	RUBBER GASKET FOR SCREW 05	3
7	77136026001	VALVE GUIDE OUTLET	4
8	77736075000	INSERT SPARK-PLUG SHAFT	1
9	77336053050	GASKET SPARK-PLUG SHAFT	1
10	0770260015	O-RING 1,5x26	2
11	77330067142	HH COLLAR SCREW M7X1X42	8
12	07700900151	O-RING 9x1,5 V80 SH	2
13	77236080000	SCREW PLUG	2
14	77336088210	COLLAR NUT M10X1,25 SW13	4
15	77336089010	WASHER 19X10,5X2,5	4
16	77230044000	STUD SCREW M10X1,25	4
17	60030063050	OIL JET 50 05	4
21	77736044000	RUBBER BOOT EFI	1
22	61036047000	HOSE CLAMP GEMI 63MM 05	1
23	77036090000	DOWEL(BUSH BRIDGE)7/9/8 05	4
24	0770100020	O-RING 10,00X2,00 SILCONE	1
25	60011252000	TEMPERAT.-SENSOR WATER LC8 02	1
26	59030296000	SCREW PLUG	1
27	58030010200	SCREW IN NOZZLE M20X1,5	1
28	77236041000	GASKET EXHAUST FLANGE	1
29	77736039000	ENGINEFLANGE	1
30	0025060166S	HH COLLAR SCREW M6X16 ISA 30	2
31	77336088106	COLLAR NUT M6X1 SW8	1
32	0125060003	WASHER DIN0125-A 6,4	1
33	77330043000	STUD SCREW M6	1
34	59031050100	ENGINE BREATHER TUBE 00	1
35	58431082300	CLAMP YDNAC 10173 (18MM)	1
40	77236048000	HOSE CLAMP GEMI 58MM	1

137773630

C147773634

* NEW PART

X ON DEMAND

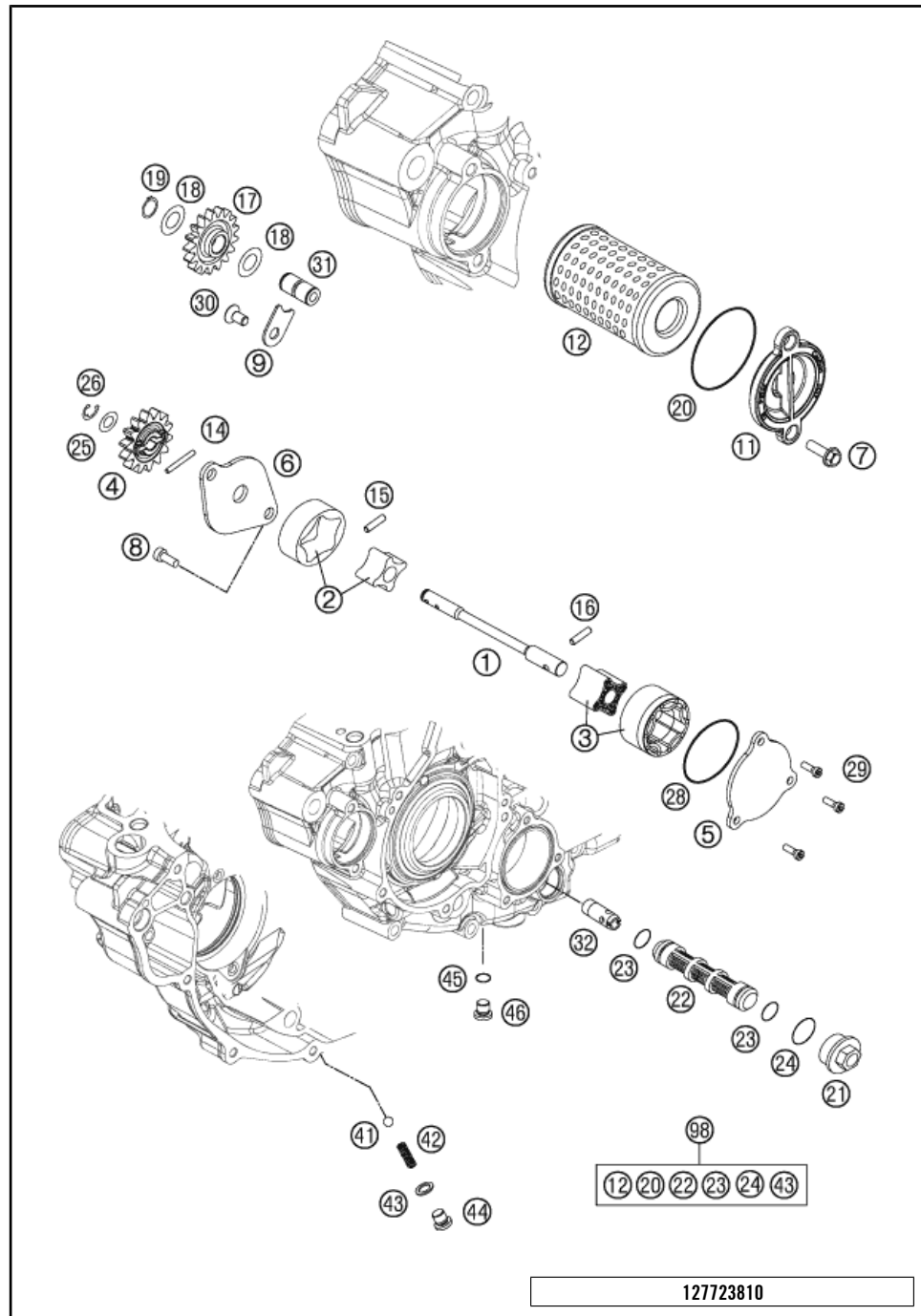

POS	PARTNUMBER	PARTNAME	PIECE
1	77238102000	OIL PUMP SHAFT	1
2	59038011012	OILPUMP ROTOR 12MM G-95R/003	1
3	61238111000	ROTOR-SET CPL. 22MM	1
4	77038001100	OIL PUMP GEAR 14T 08	1
5	78038004000	OIL PUMP COVER SUCTION PUMP	1
6	77238003100	OIL PUMP COVER R/S	1
7	0025060166	HH COLLAR SCREW M6X16 TX30	2
8	0984050123S	CYLIND. SCR. DIN6912 M5X12 8.8	2
9	77238061050	AXIAL-CIRCLIP	1
11	77338041200	OIL FILTER COVER 08	1
12	77338005100	OIL FILTER	1
14	0402251980	NEEDLEROL.DIN5402 NRA 2,5X19,8	1
15	0402251180	NEEDLE ROLLER DIN5402 2,5X11,8	1
16	0402041580	NEEDLE ROLLER NRB 4X15,8 G2	1
17	77038006100	OILPUMP IDLER GEAR 08	1
18	0988121805	SHIM WASHER DIN0988-12X18X0,50	2
19	0471120010	CIRCLIP DIN0471-12X1	1
20	07703305178	O-RING 33,05X1,78	1
21	59038017000	PLUG M20X1,5 WS=13	1
22	59038016100	OIL SCREEN	1
23*	07701250151	O-RING 12,5X1,5 VITON V75	2
24	0770020170	O-RING 17,17X1,78 GLO	1
25	58038007755	STOP DISK 8,1 X 15 X 0,5	1
26	0799060000	TAB WASHER DIN6799-RS 6,0	1
28	0770440020	O-RING 44,00X2,00 VITON	1
29	0984050163S	CYL. SCREW DIN6912 M5X16 8.8	3
30	0018050103	INT. TORX OVAL HEAD M 5X10 8.8	1
31	77038013100	BUSHING PIN	1
32	77038022000	OIL INTAKEPIPE	1
41	0401090003	BALL DIN5401-9	1
42	58038023300	PRESSURE SPRING L=25MM D=1MM	1
43	58038022000	CU-SEAL RING DIN7603-12X18X1,5	1
44	0908120153	PLUG DIN0908-M12X1,5	1
45	0770110015	O-RING 1,5X11 SILICON	1
46	78036081000	HOLDING BOLT M14X1,5	1
98	00050000083	OILFILTER-GASKET SET 350 SX-F	x

127723810

C157773810

* NEW PART

X ON DEMAND

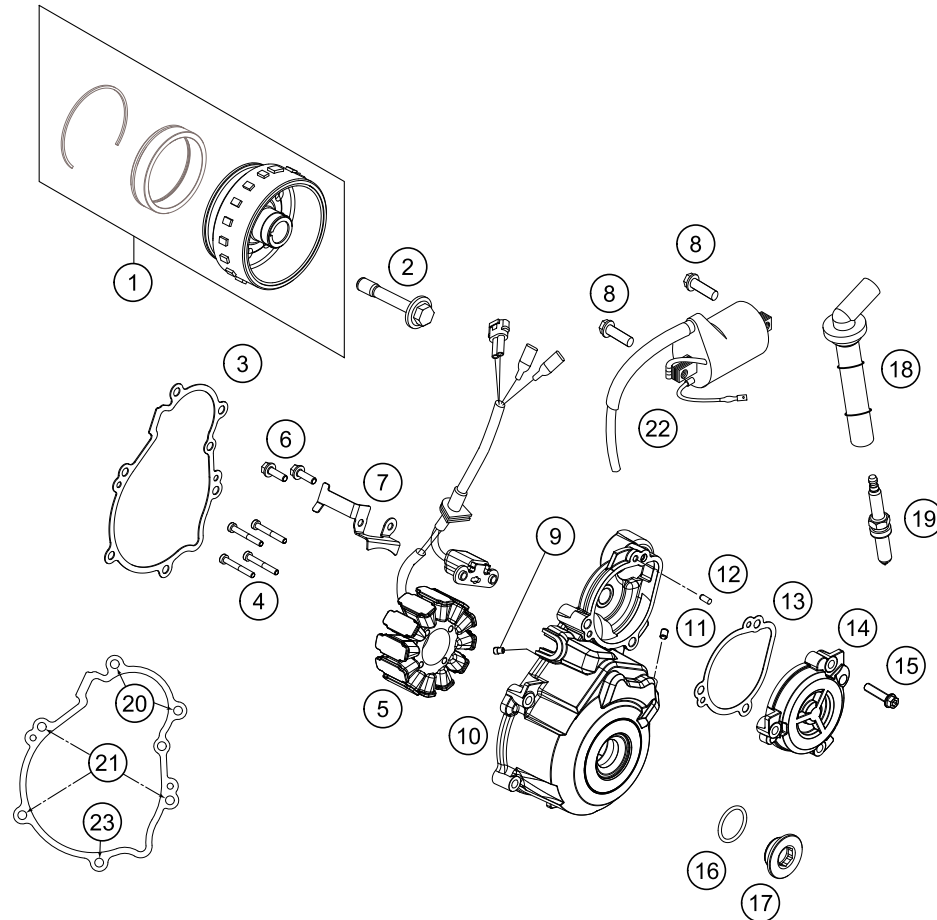

POS	PARTNUMBER	PARTNAME	PIECE
1	77839005044	ROTOR EFI CPL.	1
2	77339010100	FLYWHEEL SCREW	1
3	77530040000	IGNITION COVER GASKET	1
4	0012040303	AH SCREW DIN6912 M4x30	4
5	77239004000	STATOR	1
6	0025050166	HH COLLAR SCREW M5X16 TX30	2
7	77230002050	WIRING RETAINING BRACKET	1
8	0025060166	HH COLLAR SCREW M6X16 TX30	2
9	80030058060	OIL JET "60" M4	1
10	77230002000KA	IGNITION COVER	1
11	0913050063	THREAD PIN DIN 913 M5X6	1
12	0402040980	NEEDLE ROL.DIN5402 NRB 4X9,8	2
13	77240043000	GASKET TORQUE LIMITER	1
14	77230002010KA	COVER TORQUE LIMITER	1
15	0025060256	HH COLLAR SCREW M6X25 TX30	1
16	07700240251	O-RING 24X2,5 VITON	1
17	7723000206068	IGNITION COVER PLUG M24X1,5	1
18	77739090000	SPARK PLUG CONNECTOR	1
19	77239093000	PLUG NGK LMAR9AI - 8	1
20	0025060506	HH COLLAR SCREW M6X50 TX30	2
21	0025060306	HH COLLAR SCREW M6X30 TX30	3
22	58439006000	IGNITIONCOIL IG3826 KOKUSAN'96	1
23	0025060406	HH COLLAR SCREW M6X40 TX30	1

147773910

C147773914

* NEW PART

X ON DEMAND

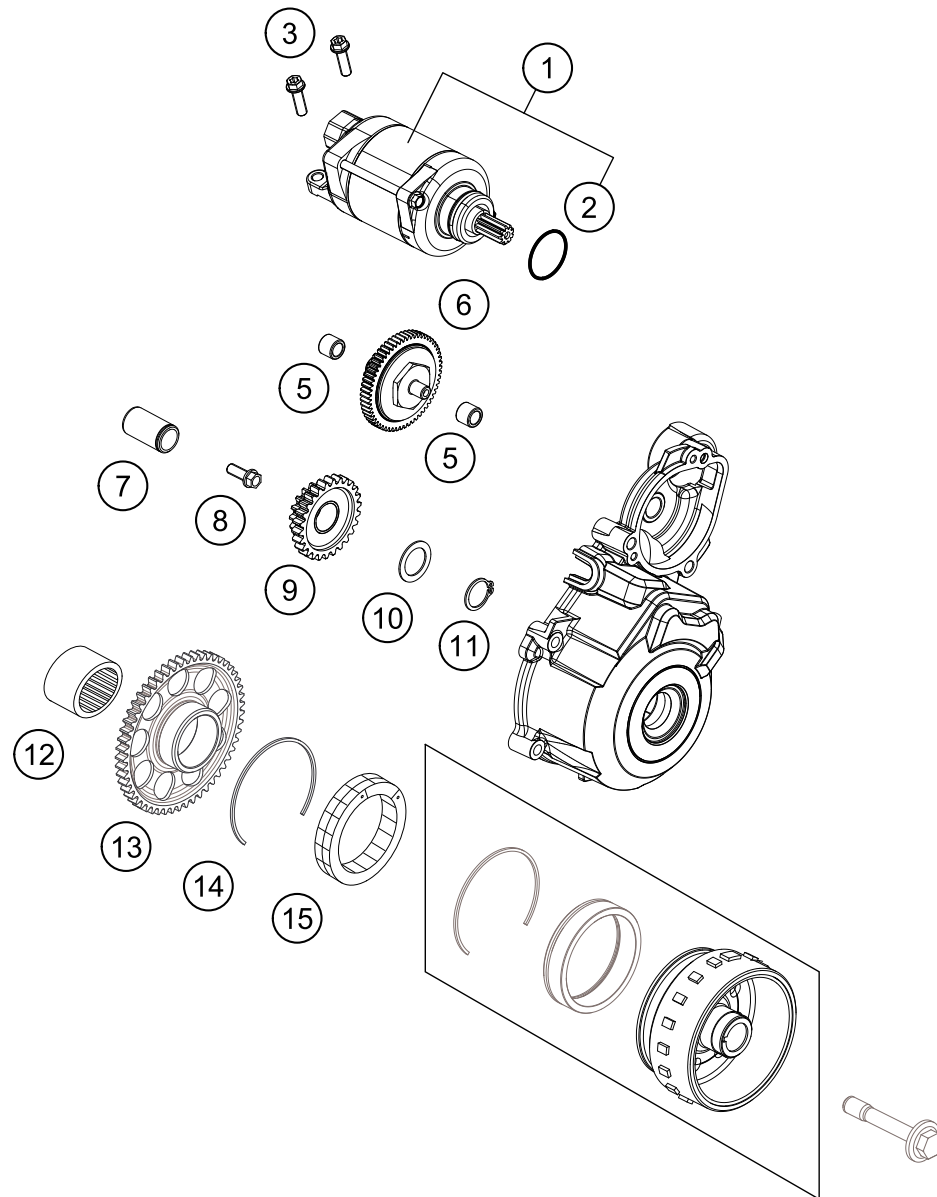

POS	PARTNUMBER	PARTNAME	PIECE
1	77240001100	E-STARTER ENGINE CPL.	1
2	0770250030	O-RING 25,00X3,00 NBR 70	1
3	0025060256	HH COLLAR SCREW M6X25 TX30	2
5	0618081210	NEEDLE BUSH HK 0810 DIN 618	2
6	77240016000	TORQUE LIMITER	1
7	59040028000	BUSHING PIN	1
8	0015060163	HH COLLAR SCREW M 6X16 WS=8	1
9	77240022000	INTERMEDIATE STARTING GEAR	1
10	54633090000	STOP DISK 17,2X25X1	1
11	0471170010	CIRCLIP DIN0471-17X1	1
12	0618253216	NEEDLE BUSH HK2516 25/32/16 02	1
13	77840020000	FREEWHEEL GEAR	1
14	0472057150	CIRCLIP DIN0472-57X1,50	1
15	80040026000	FREE WHEEL 03	1

147774010

C147774011

* NEW PART

X ON DEMAND

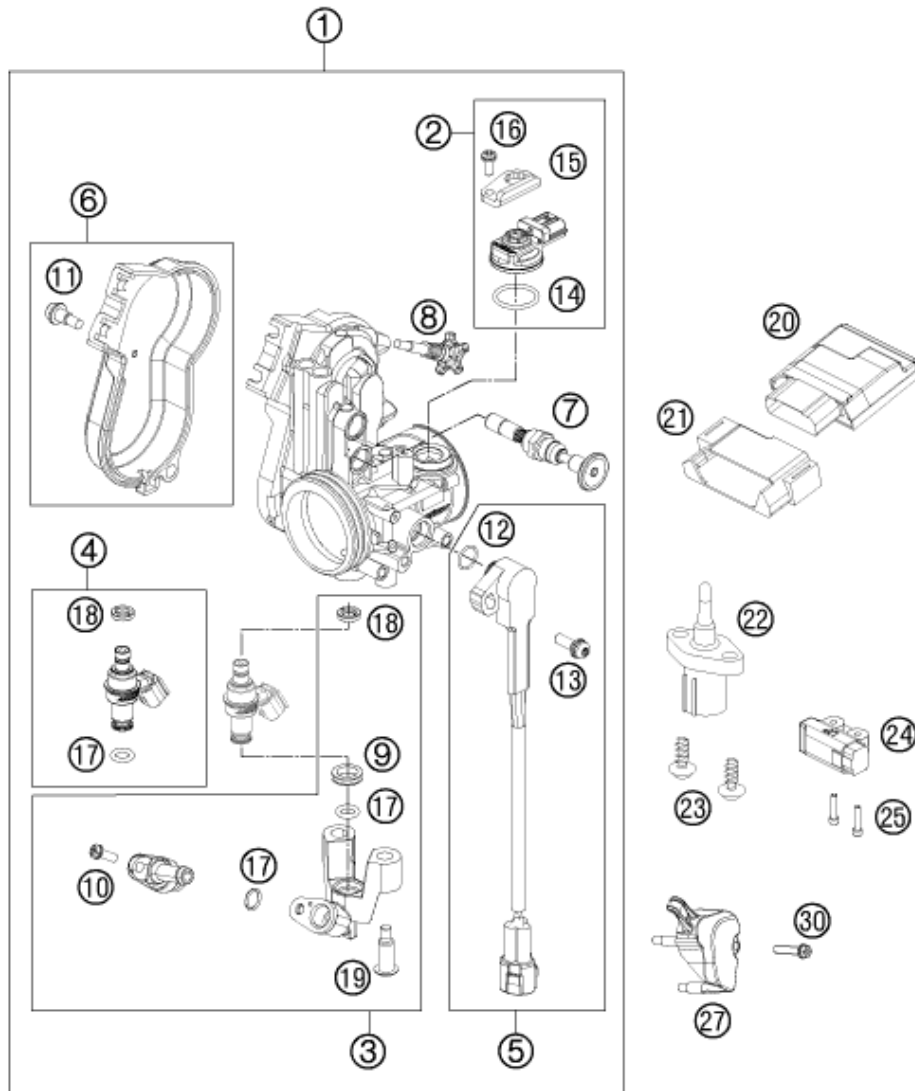

POS	PARTNUMBER	PARTNAME	PIECE
1	77741001000	THROTTLE BODY	1
2	75041085044	MAP SENSOR CPL. 07	1
3	77741013044	FUEL RAIL CPL.	1
4	77741023044	INJECTOR KIT CPL.	1
5	77741077044	TPS CPL.	1
6	81241056044	THROTTLE COVER CPL. 09	1
7	77741070000	STARTER VALVE COMP.	1
8	77741060044	IDLING ADJUSTING SCREW CPL.	1
9	77741023030	SEAL RING	1
10	75041013010	SCREW SHOULDER	1
11	81241056020	SPECIAL SCREW AH	2
12	61041077010	O-RING THROTTLE POS. SENSOR	1
13	81241077030	SPECIAL SCREW	1
14	75041085010	O-RING	1
15	77741085020	PLATE	1
16	81241085030	SPECIAL SCREW	1
17	75041023020	O-RING 7,2x2,2	2
18	75041023010	SEAL RING	1
19	75041013060	SCREW SHOULDER	2
20	81241031000	% TIMING CHARGER EFI	1
21	77241035050	ECU SAFETY COVER	1
22	61041080000	AMBIENT-AIR TEMPERATURE SENSOR	1
23	0025050166	HH COLLAR SCREW M5X16 TX30	2
24	61041088000	ROLLOVER SENSOR 05	1
25	0025060206	HH COLLAR SCREW M6X20 TX30	2
27	77741077050	PROTECTION CAP TPS	1
30	0025050256	HH COLLAR SCREW M5X25 ISA30	1

137894110

C147774112

* NEW PART

X ON DEMAND



3CM0893310EN



Husqvarna Motorcycles GmbH
Stallhofnerstraße 3 | 5230 Mattighofen | Austria
www.husqvarna-motorcycles.com



THE PIONEERS OF MOTOCROSS