



Husqvarna®

TC 449/2012



INFORMAZIONI GENERALI

Il presente catalogo serve per richiedere con esattezza le parti di ricambio
Nelle ordinazioni indicare:

- 1) il numero di codice dei particolari seguito dalla descrizione;
 - 2) il colore per i pezzi verniciati o comunque colorati;
 - 3) il numero di matricola del motociclo, stampigliato sul canotto di sterzo.
- Le indicazioni destra e sinistra si riferiscono ai lati del veicolo rispetto al senso di marcia;

GENERAL INFORMATION

The present spare parts list enables one to order exactly the right spare parts.
When ordering specify:

- 1) the part's code number followed by its description;
 - 2) indicate colour for painted or coloured parts;
 - 3) the motorcycle's serial number, stamped on the steering head.
- References to right and left apply to the vehicle in terms of its direction of movement.

INFORMATIONS GENERALES

Ca catalogue permet de commander correctement les pièces de rechange.
Les commandes doivent être passées en indiquant:

- 1) le numéro de code des pièces détachées suivi de leur description;
 - 2) le couleur des pièces peintes ou colorés;
 - 3) le matricule de la moto, estampillé sur la tige du guidon.
- Droite et gauche sont les côtés du véhicule par rapport au sens de la marche.

ALLGEMEINE HINWEISE

Dieser Ersatzteilkatalog dient zur genauen Angabe der Teile bei Ersatzteilbestellungen.

- Bei Ersatzbestellung ist folgendes anzugeben:
- 1) Die Bestellnummer der Ersatzteile mit der entsprechenden Beschreibung;
 - 2) Farbe für lackierte und farbige Teile angeben;
 - 3) Die Sseriennummer des Motorrads, die am Lenkrohr eingepägt ist.
- Die Angaben rechts und links beziehen sich auf das Fahrzeug in Fahrriichtung.

INFORMACIONES GENERALES

El presente catálogo sirve para pedir con exactitud las partes de recambio.
En los pedidos se debe indicar:

- 1) el número de código de la parte y a continuación la descripción;
 - 2) el color para las piezas barnizadas o coloreadas;
 - 3) el número de matrícula de la motocicleta, estampado en le tubo de dirección.
- Las indicaciones derecha e izquierda se refieren a los lados del vehículo respecto del sentido de marcha.

NOTE - LIST - NOTES - NOTE - NOTAS:

- A** : In alternativa - In alternative - En alternative - Wahlweise - En alternativa
- D** : In dotazione - To issue - En nécessaire - Ausrüstungsteile - En dotación
- E** : Ad esaurimento - To fell out - A' finir - Erschöpfung - A agotamiento
- F** : Fornire assieme - Supply unitedly - Fournir ensemble - Wird zusammen geliefert Equipar juntos
- H** : Potenziamento per uso sportivo su circuito di gara - Powering for racing use on circuit - Augmentation de la puissance pour usage sportif sur piste - Potenzierung für wettkämpferischen Gebrauch des Motorrad - Aumento de la potencia para uso agonístico sobre circuito de competición
- N** : Non fornito - Not supplied - Ne pas fournir - Keine Gelieferende - No equiparado
- R** : A richiesta - Upon request - Sur demande - Auf anfrage - a pedimento
- S** : Di serie - Supplied - De sèrie - Standard - De serie
- U** : Solo per U.S.A - Only for U.S.A. - Seulement pour U.S.A - Nur für U.S.A - Solo por U.S.A
- Z** : n° denti, number of teeth, numéro dents, Zähne nummer - número dientes

- A** : Austria, Austria, Autriche, Österreich, Austria
- AUS** : Australia, Australia, Australie, Australien, Australia
- B** : Belgio, Belgium, Belgique, Belgien, Bélgica
- BR** : Brasile, Brazil, Brasile, Brasilien, Brasil
- CDN** : Canada, Canada, Canada, Kanada, Canadá
- CH** : Svizzera, Switzerland, Suisse, Schweizer, Suiza
- D** : Germania, Germany, Allemagne, Deutschland, Alemania
- E** : Spagna, Spain, Espagne, Spanien, España
- F** : Francia, France, France, Frankreich, Francia
- GB** : Gran Bretagna, Great Britain, Grand Bretagne, Groos Britan, Gran Bretaña
- I** : Italia, Italy, Italie, Italien, Italia
- J** : Giappone, Japan, Japon, Japan, Japón
- SF** : Finlandia, Finald, Finlande, Finnland, Finlandia
- USA** : Stati Uniti d'America, United States of America, Etats Units d'Amérique, Vereinigte Staaten von Amerika, Estados Unidos

Dati indicativi soggetti a modifiche senza impegno di preavviso.
All data are subject to modification without prior notice.
Données indicatif sujet au modifications sans obligation de préavis.
Anderungen Vorbehalten.
Datos indicativos sujetos a modificaciones sin compromiso de preaviso.

N° DI MATRICOLA INIZIALE - INITIAL SERIAL NUMBER - MATRICULE INITIAL - BEGINNTERIENNUMMER - MATRICULA INICIAL	
MODELLO - MODEL MODELE - MODELL MODELO	MATRICOLA - SERIAL NUMBER MATRICULE - SERIENNUMMER MATRICULA
TC 449/EUR	ZKHA600AACV050001
TC 449/USA	ZKHTC453*CV000001

Tavola Drawing Table Bild Tabla	Denominazione	Description	Designation	Bezeichnung	Denominacion	Pagina Page Page Seite Paja
1	ATTREZZI DI ASSISTENZA, MANUALI E CATALOGHI	SERVICE TOOLS, MANUALS AND CATALOGS	OUTILS D'ASSISTANCE, MANUELS ET CATALOGUES	HILFAUSRUSTUNG, HANDBUCH UND KATALOG	HERRAMIENTAS DE ASISTENCIA, MANUALES Y CATALOGOS	13
2	SEMICARTER 1/2	HALF CRANKCASE 1/2	CARTER 1/2	GEHAUSEDECKEL 1/2	BANCADA 1/2	15
3	SEMICARTER 2/2	HALF CRANKCASE 2/2	CARTER 2/2	GEHAUSEDECKEL 2/2	BANCADA 2/2	17
4	COPERCHI SEMICARTER SX	L.H. HALF CRANKCASE COVERS	COUVERCLES CARTER G.	GEHAUSEDECKEL L.	TAPAS BANCADA IZQ.	19
5	COPERCHI SEMICARTER DX	R.H. HALF CRANKCASE COVERS	COUVERCLES CARTER D.	GEHAUSEDECKEL R.	TAPAS BANCADA DER.	21
6	ALBERO DI COMPENSAZIONE	BALANCE SHAFT	ARBRE DE COMPENSATION	COMPENSATIONSWELLE	EJE DE COMPENSACION	23
7	LIMITATORE DI COPPIA PRIMARIO	PRIMARY TORQUE LIMITER	LIMITEUR DE COUPLE PRIMAIRE	PRIMÄRER DREHMOMENTBEGRENZER	LIMITADOR DE PAR PRIMARIO	25
8	CILINDRO, PISTONE	CYLINDER, PISTON	CYLINDRE, PISTON	ZYLINDER, KOLBEN	CILINDRO, PISTON	27
9	TESTA CILINDRO 1/2	CYLINDER HEAD 1/2	CULASSE 1/2	ZYLINDERKOPF 1/2	CULATA 1/2	29
10	TESTA CILINDRO 2/2	CYLINDER HEAD 2/2	CULASSE 2/2	ZYLINDERKOPF 2/2	CULATA 2/2	31
11	MANOVELLISMO	CRANKSHAFT	VILEBREQUIN	KURBELWELLE	CIGÜEÑAL	33
12	DISTRIBUZIONE	VALVE TIMING	DISTRIBUTION	VENTILSTEUERUNG	DISTRIBUCION	35
13	ALBERO A CAMME ASPIRAZIONE-SCARICO	INTAKE-EXHAUST CAMSHAFT	ARBRE DISTRIBUTION ADMISSION-ECHAPPEMENT	NOCKENWELLE ANSAUGSEITE-AUSPUFFSEITE	EJE DISTRIBUCIÓN ASPIRACION-DESCARGA	37
14	VALVOLA ASPIRAZIONE-SCARICO	INLET-EXHAUST VALVE	SOUPAPE ADMISSION-D'ECHAPPEMENT	EINLASS-AUSLASS VENTIL	VÁLVULA ASPIRACIÓN-DE ESCAPE	39
15	FILTRO OLIO	OIL FILTER	FILTER HUILE	ÖLFILTER	FILTRO ACEITE	43
16	LUBRIFICAZIONE 1/2	OIL PUMP 1/2	PUMPE HUILE 1/2	MOTORSCHMIERUNG 1/2	LUBRICACION 1/2	45
17	LUBRIFICAZIONE 2/2	OIL PUMP 2/2	PUMPE HUILE 2/2	MOTORSCHMIERUNG 2/2	LUBRICACION 2/2	47
18	POMPA ACQUA	WATER PUMP	POMPE À EAU	WASSERPUMPE	BOMBA DE AGUA	49
19	ALTERNATORE	ALTERNATOR	ALTERNATEUR	LICHTMASCHINE	ALTERNADOR	51
20	MOTORINO AVVIAMENTO	START MOTOR	MOTEUR DÉMARRAGE	ELEKTR ANLASSER	MOTOR DE ARRANQUE	53
21	FRIZIONE	CLUTCH	EMBAYAGE	KUPPLUNG	EMBRAGUE	55
22	COMANDO CAMBIO	GEARSHIFT MECHANISM	COMMANDE DE VITESSE	GANGSCHALTUNG	MANDO CAMBIO	57
23	TRASMISSIONE PRIMARIA	PRIMARY DRIVE	TRANSMISSION PRIMAIRE	PRIMÄRÜBERSETZUNG	TRANSMISION PRIMARIA	59
24	FILTRO ARIA	AIR FILTER	FILTRE AIRE	LUFTFILTER	FILTRO DE AIRE	63
24A	CORPO FARFALLATO	THROTTLE BODY	CORP PAPILLON	DROSSELKLAPPENKÖRPER	CUERPO OSCILANTE	65
25	IMPIANTO DI RAFFREDAMENTO	COOLING SYSTEM	INSTALLATION RAFROIDISSEMENT	SCHMIERUNGSSYSTEM	EQUIPO DE ENFRIAMIENTO	67
26	TELAIO, PEDANE	FRAME, FOOT RESTS	CADRE, REPOSE PIEDS	RAHMEN, FUSSBRETT	BASTIDOR, REPOSAPIES	69
27	SOSPENSIONE ANTERIORE 1/2	FRONT FORK ASSEMBLY 1/2	SUSPENSION AVANT 1/2	VORDETELESKOPGABEL 1/2	SUSPENSION DELANTERA 1/2	71
27A	SOSPENSIONE ANTERIORE 2/2	FRONT FORK ASSEMBLY 2/2	SUSPENSION AVANT 2/2	VORDETELESKOPGABEL 2/2	SUSPENSION DELANTERA 2/2	73
28	FORCELLONE POSTERIORE	REAR SWING ARM	FOURCHE ARRIERE	HINTERGABEL	HORQUILLA TRASERA	75
29	LEVRAGGI SOSPENSIONI POSTERIORE	REAR SUSPENSION LINKAGE	LEVIER SUSPENSION ARRIERE	HEBELWERK HINTERHAUFHANGUNG	PALANCA SUSPENSION TRASERA	79
30	AMMORTIZZATORE POSTERIORE	REAR SUSPENSION	SUSPENSION ARRIERE	HINTERHAUFHANGUNG	SUSPENSION TRASERA	81

Tavola Drawing Table Bild Tabla	Denominazione	Description	Designation	Bezeichnung	Denominacion	Pagina Page Page Seite Paja
31	MANUBRIO E COMANDI	HANDLEBAR AND CONTROLS	GUIDON ET COMMANDES	LENKER UND STEUERORGANE	MANILLAR Y MANDOS	83
32	PANNELLI, PARAFANGHI, SELLA	PANEL, FENDERS, SEAT,	PANNEAU, GARDE-BOUES, SIEGE,	STREIFEN, KOTFLUGEL, SATTEL	PANELO, GUARDABARROS, SILLIN	85
33	SERBATOIO CARBURANTE	GAS TANK	RESERVOIR CARBURANT	KRAFTSTOFFBEHALTER	DEPOSITO GASOLINA	89
34	SCARICO	EXHAUST SYSTEM	TUYAU D'ECHAPPEMENT	AUSPUFFROHR	TUBO DE ESCAPE	91
35	FRENO IDRAULICO ANTERIORE	FRONT HYDRAULIC BRAKE	FREIN HYDRAULIQUE AVANT	VORDERBREMSE	FRENO HIDRAULICO DELANTERO	93
36	FRENO IDRAULICO POSTERIORE	REAR HYDRAULIC BRAKE	FREIN HYDRAULIQUE ARRIERE	HINTERBREMSE	FRENO HIDRAULICO TRASERO	95
37	RUOTA ANTERIORE	FRONT WHEEL	ROUE AVANT	VORTERRAD	RUEDA DELANTERA	97
38	RUOTA POSTERIORE	REAR WHEEL	ROUE ARRIERE	HINTERRAD	RUEDA TRASERA	99
39	GRUPPO CAVI, PARTI ELETTRICHE	MAIN WIRING HARNESS, ELECTRICAL PARTS	CABLES PRINCIPAL, PARTIES ELECTRIQUES	KABEL, ELEKTRISCHE KOMPONENTE	GRUPO PRINCIPAL CABLES PARTES ELECTRICAS	101
40	DECALCOMANIE	TRANSFER	DECALCOMANIE	ABZIEHBILD	CALCOMANIA	103
-	INDICE NUMERICO PROGRESSIVO	NUMERICAL INDEX	INDEX NUMERIQUE	NUMMERNVERZEICHNIS	ÍNDICE NUMÉRICO PROGRESIVO	104

Tavola - Drawing - Table - Bild - Tabla

1

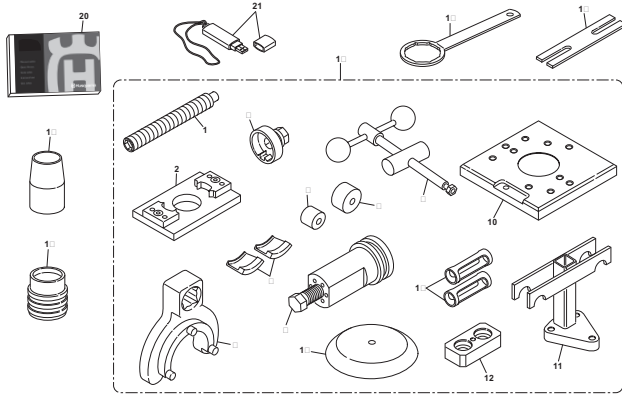

Pagina - Page - Page - Seite - Paja

12

Tavola - Drawing - Table - Bild - Tabla

2

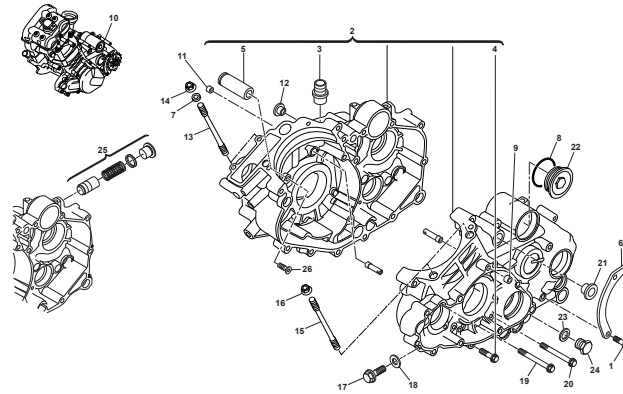

Pagina - Page - Page - Seite - Paja

14

Tavola - Drawing - Table - Bild - Tabla

3

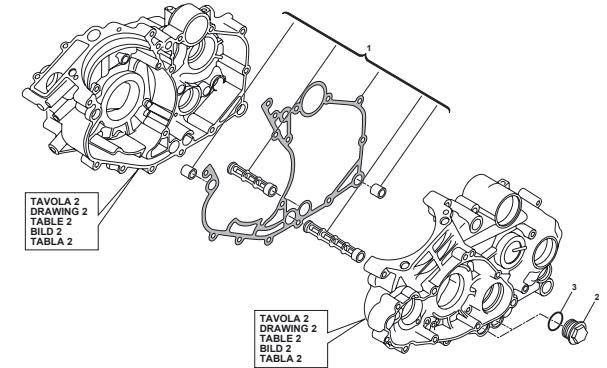

Pagina - Page - Page - Seite - Paja

16

Tavola - Drawing - Table - Bild - Tabla

4

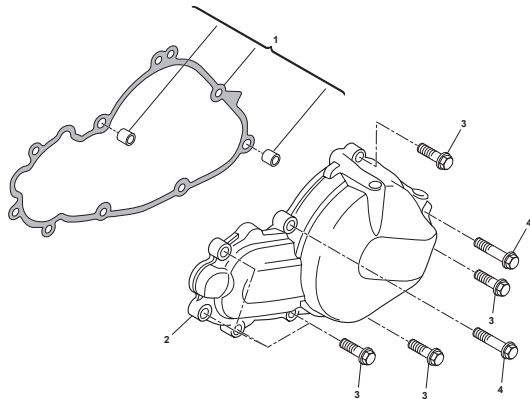

Pagina - Page - Page - Seite - Paja

18

Tavola - Drawing - Table - Bild - Tabla

5

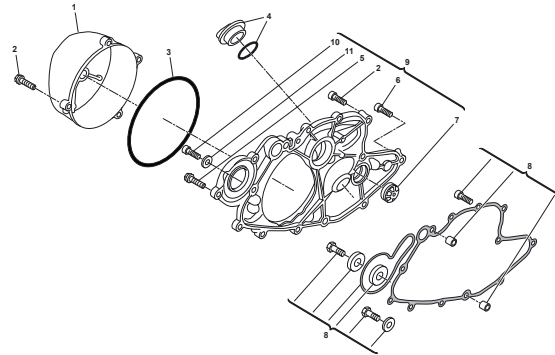

Pagina - Page - Page - Seite - Paja

20

Tavola - Drawing - Table - Bild - Tabla

6

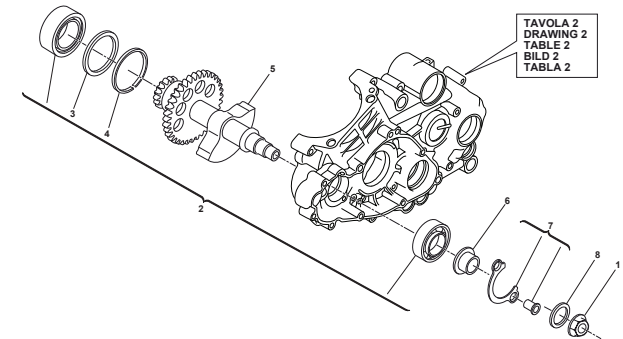

Pagina - Page - Page - Seite - Paja

22

<p>Tavola - Drawing - Table - Bild - Tabla</p> <p style="text-align: right;">7</p>  <p>Pagina - Page - Page - Seite - Paja</p> <p style="text-align: right;">24</p>	<p>Tavola - Drawing - Table - Bild - Tabla</p> <p style="text-align: right;">8</p>  <p>Pagina - Page - Page - Seite - Paja</p> <p style="text-align: right;">26</p>	<p>Tavola - Drawing - Table - Bild - Tabla</p> <p style="text-align: right;">9</p>  <p>Pagina - Page - Page - Seite - Paja</p> <p style="text-align: right;">28</p>
<p>Tavola - Drawing - Table - Bild - Tabla</p> <p style="text-align: right;">10</p>  <p>Pagina - Page - Page - Seite - Paja</p> <p style="text-align: right;">30</p>	<p>Tavola - Drawing - Table - Bild - Tabla</p> <p style="text-align: right;">11</p>  <p>Pagina - Page - Page - Seite - Paja</p> <p style="text-align: right;">32</p>	<p>Tavola - Drawing - Table - Bild - Tabla</p> <p style="text-align: right;">12</p>  <p>Pagina - Page - Page - Seite - Paja</p> <p style="text-align: right;">34</p>

Tavola - Drawing - Table - Bild - Tabla

13

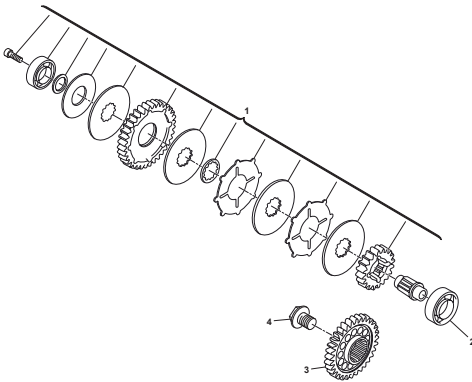
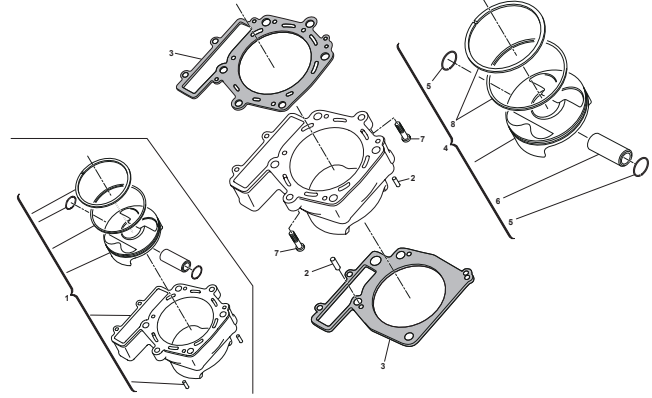
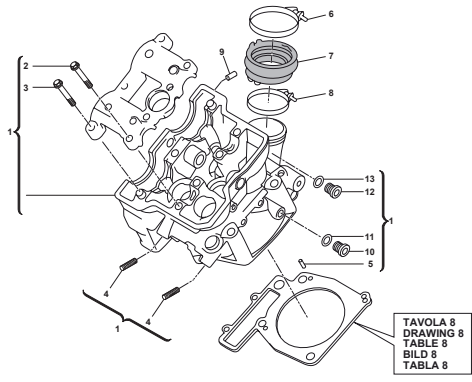
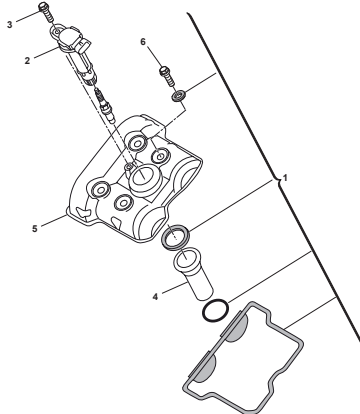
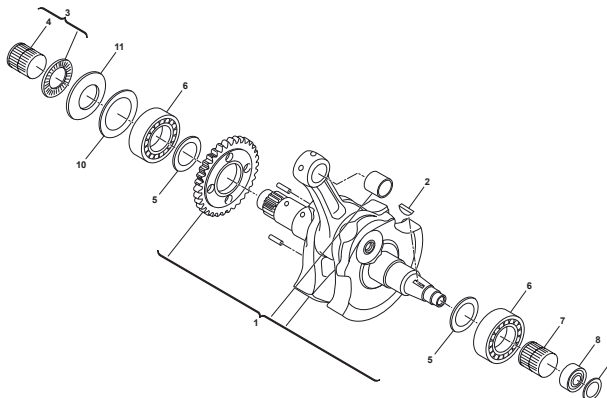
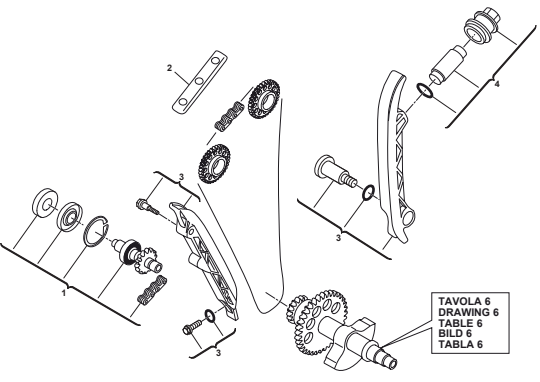
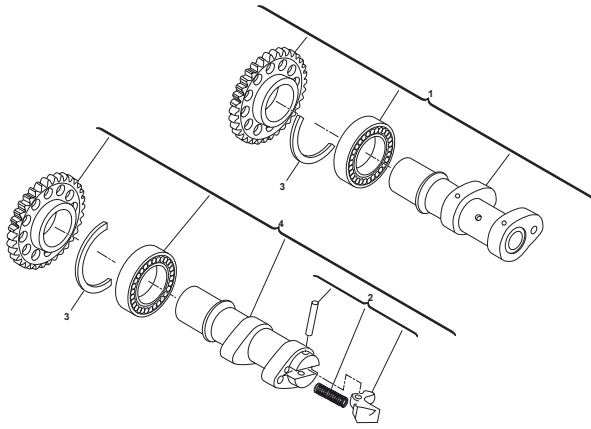

Pagina - Page - Page - Seite - Paja

36

Tavola - Drawing - Table - Bild - Tabla

14

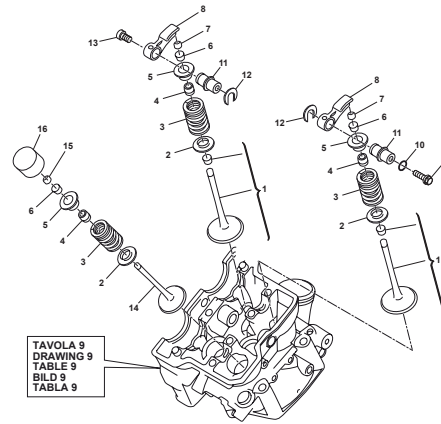

Pagina - Page - Page - Seite - Paja

38

Tavola - Drawing - Table - Bild - Tabla

15

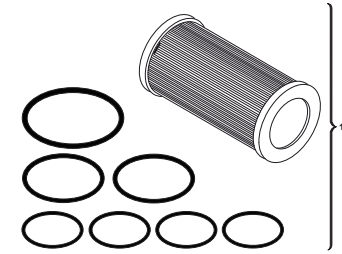

Pagina - Page - Page - Seite - Paja

42

Tavola - Drawing - Table - Bild - Tabla

16

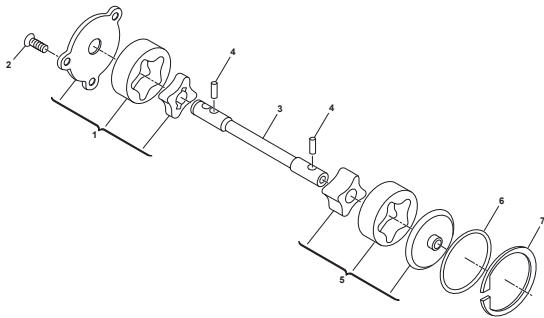

Pagina - Page - Page - Seite - Paja

44

Tavola - Drawing - Table - Bild - Tabla

17

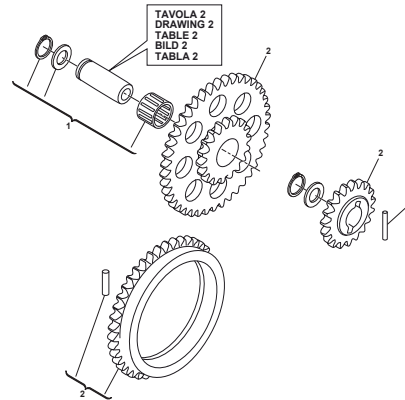

Pagina - Page - Page - Seite - Paja

46

Tavola - Drawing - Table - Bild - Tabla

18

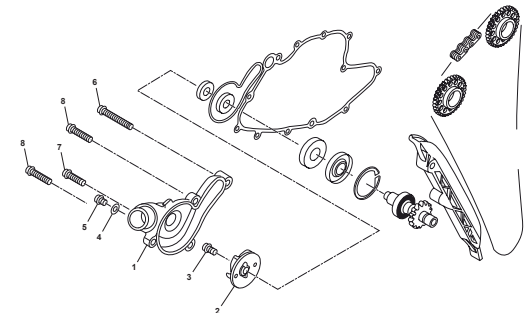

Pagina - Page - Page - Seite - Paja

48

Tavola - Drawing - Table - Bild - Tabla

19

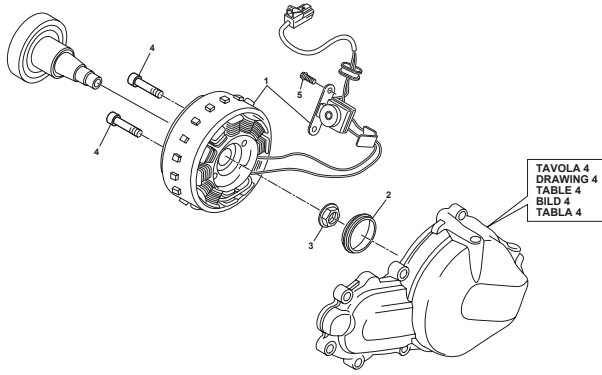

Pagina - Page - Page - Seite - Paja

50

Tavola - Drawing - Table - Bild - Tabla

20

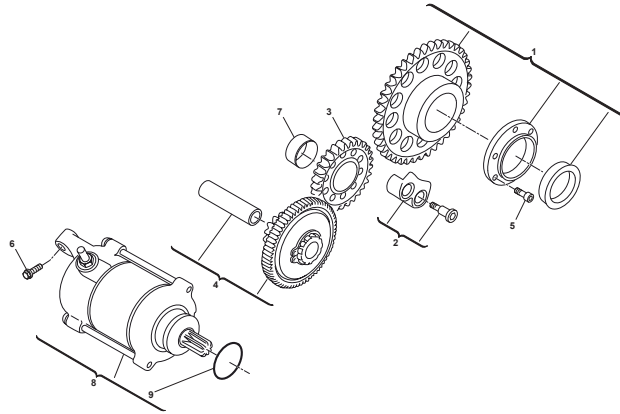

Pagina - Page - Page - Seite - Paja

52

Tavola - Drawing - Table - Bild - Tabla

21

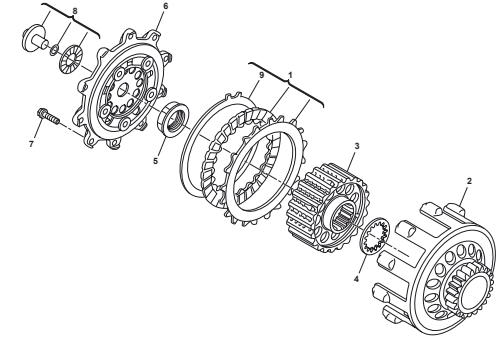

Pagina - Page - Page - Seite - Paja

54

Tavola - Drawing - Table - Bild - Tabla

22

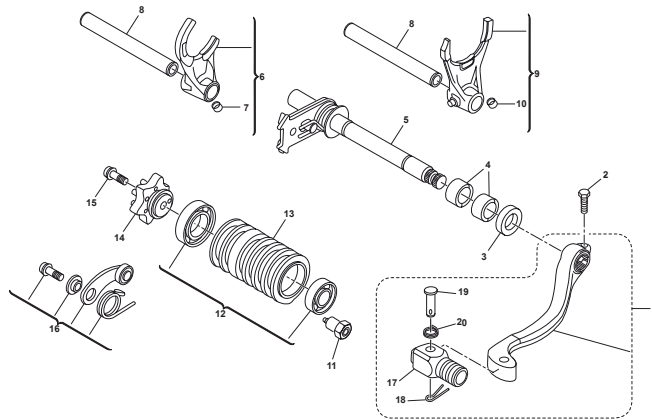

Pagina - Page - Page - Seite - Paja

56

Tavola - Drawing - Table - Bild - Tabla

23

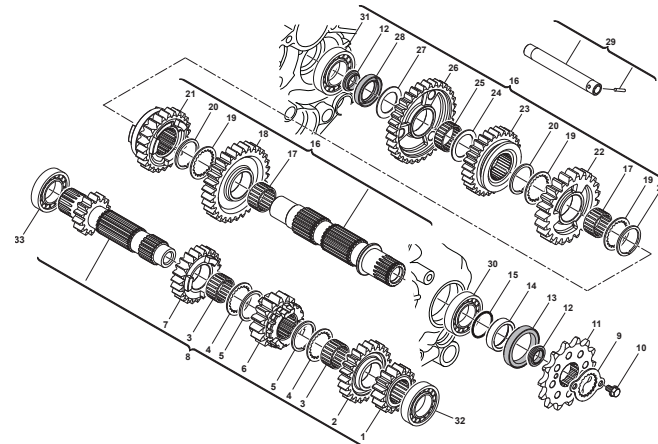

Pagina - Page - Page - Seite - Paja

58

Tavola - Drawing - Table - Bild - Tabla

24

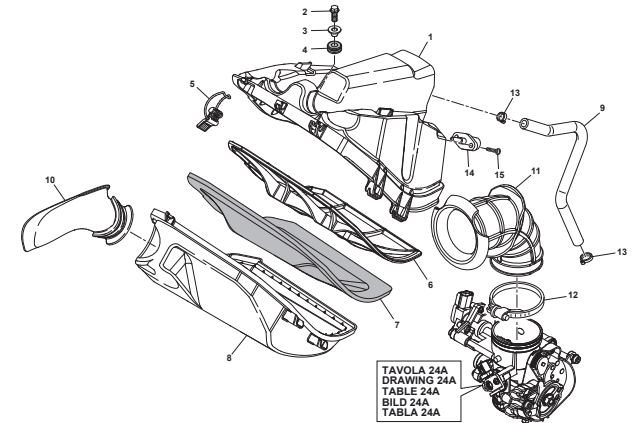

Pagina - Page - Page - Seite - Paja

62

Tavola - Drawing - Table - Bild - Tabla

24A

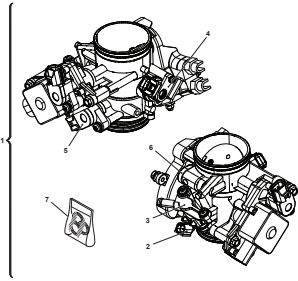

Pagina - Page - Page - Seite - Paja

64

Tavola - Drawing - Table - Bild - Tabla

25

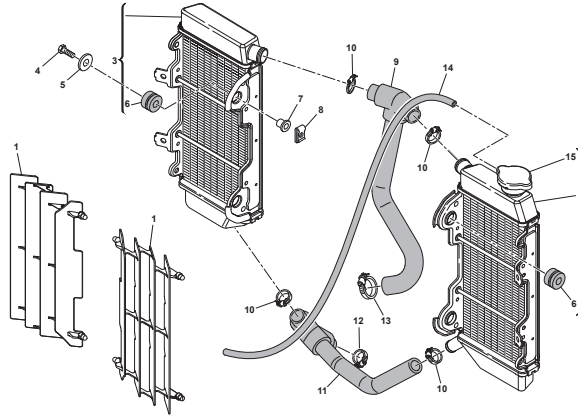

Pagina - Page - Page - Seite - Paja

66

Tavola - Drawing - Table - Bild - Tabla

26

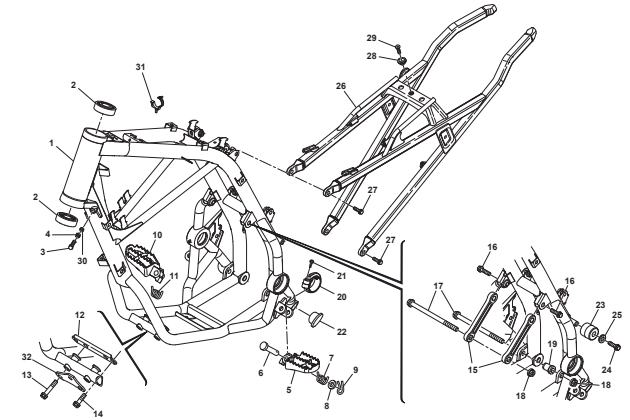

Pagina - Page - Page - Seite - Paja

68

Tavola - Drawing - Table - Bild - Tabla

27

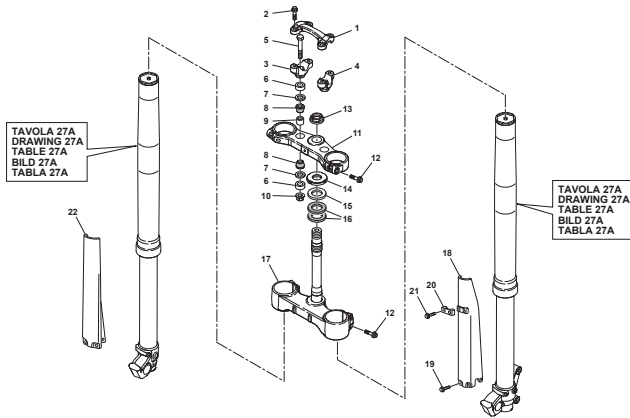

Pagina - Page - Page - Seite - Paja

70

Tavola - Drawing - Table - Bild - Tabla

27A

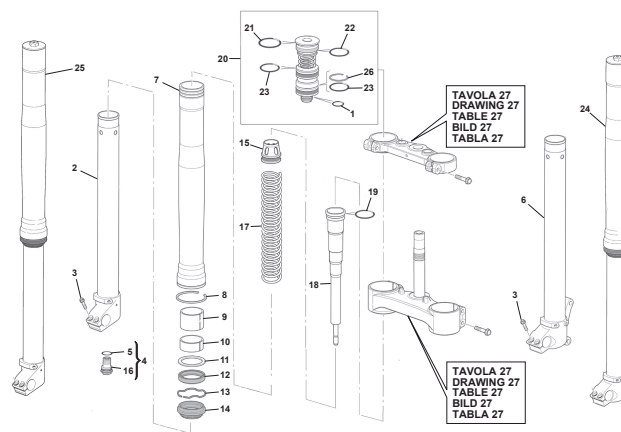

Pagina - Page - Page - Seite - Paja

72

Tavola - Drawing - Table - Bild - Tabla

28

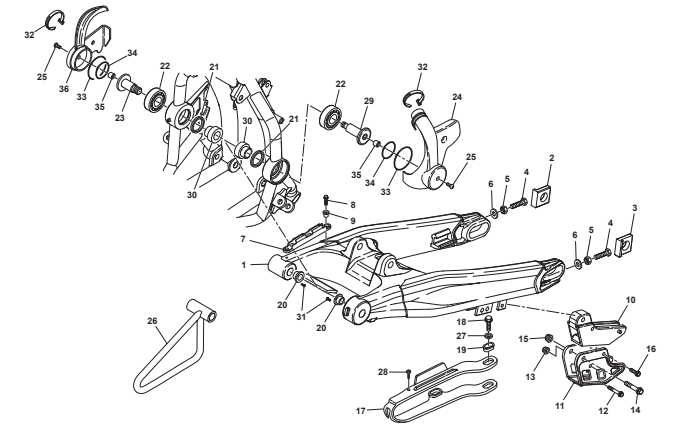

Pagina - Page - Page - Seite - Paja

74

Tavola - Drawing - Table - Bild - Tabla

29



Tavola - Drawing - Table - Bild - Tabla

30

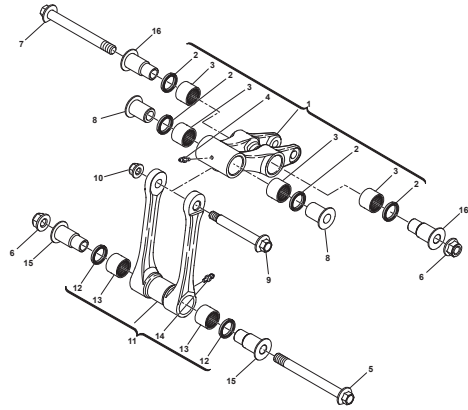

TAVOLA 29
DRAWING 29
TABLE 29
BILD 29
TABLA 29

Tavola - Drawing - Table - Bild - Tabla

31

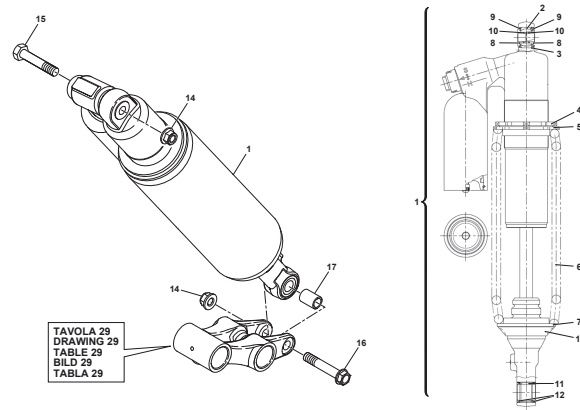
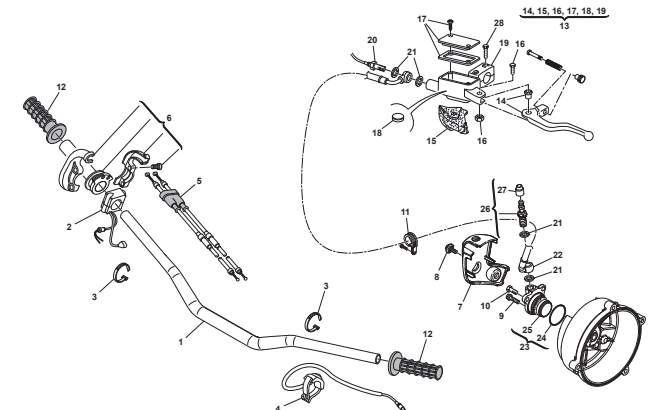

Pagina - Page - Page - Seite - Paja

78

Pagina - Page - Page - Seite - Paja

80

Pagina - Page - Page - Seite - Paja

82

Tavola - Drawing - Table - Bild - Tabla

32



Tavola - Drawing - Table - Bild - Tabla

33

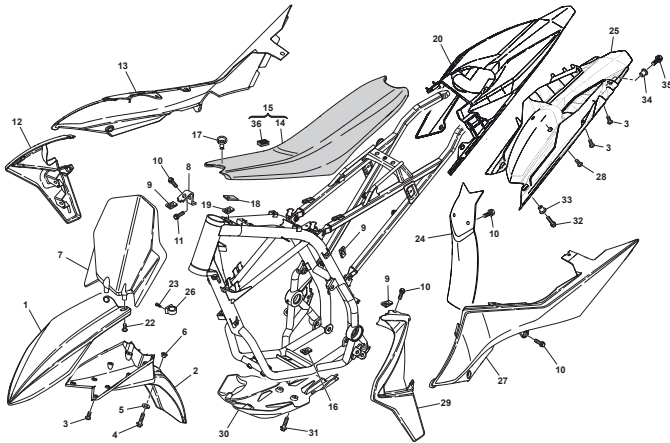

TAVOLA 24A
DRAWING 24A
TABLE 24A
BILD 24A
TABLA 24A

Tavola - Drawing - Table - Bild - Tabla

34

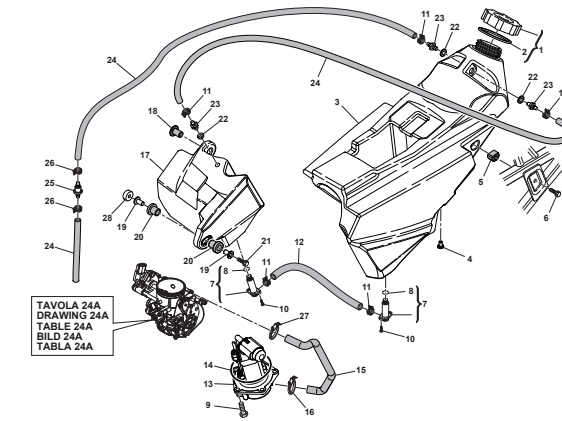
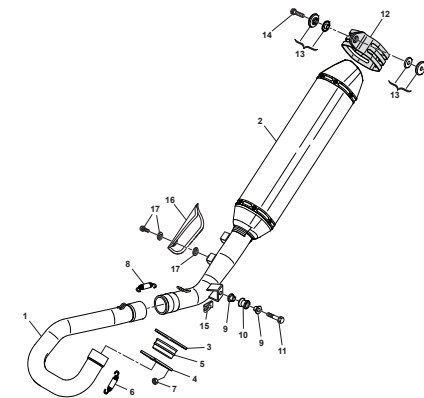

Pagina - Page - Page - Seite - Paja

84

Pagina - Page - Page - Seite - Paja

88

Pagina - Page - Page - Seite - Paja

90

Tavola - Drawing - Table - Bild - Tabla

35

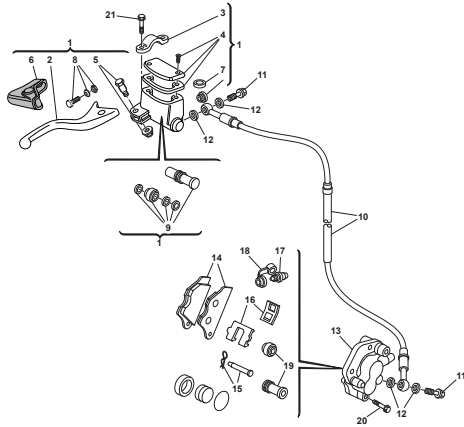

Pagina - Page - Page - Seite - Paja

92

Tavola - Drawing - Table - Bild - Tabla

36

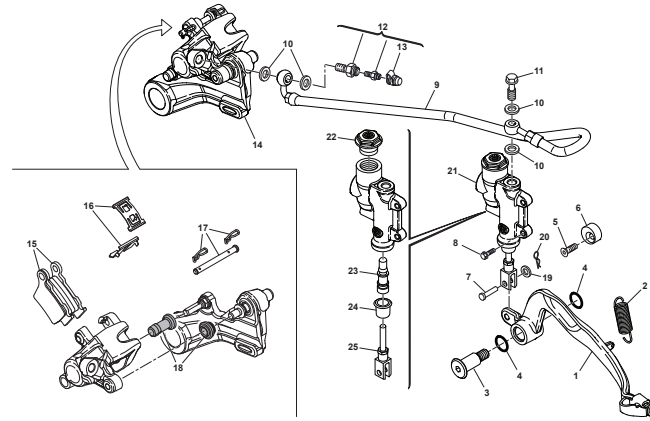

Pagina - Page - Page - Seite - Paja

94

Tavola - Drawing - Table - Bild - Tabla

37

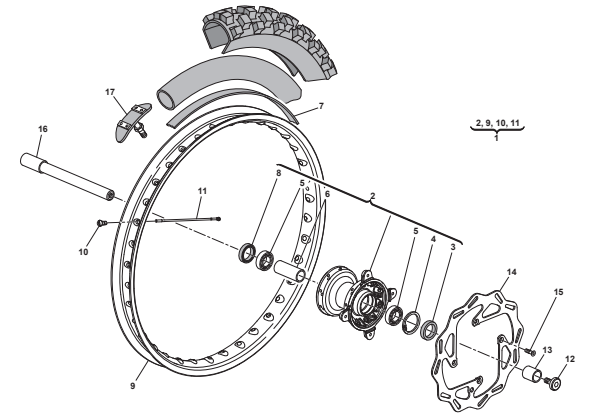

Pagina - Page - Page - Seite - Paja

96

Tavola - Drawing - Table - Bild - Tabla

38

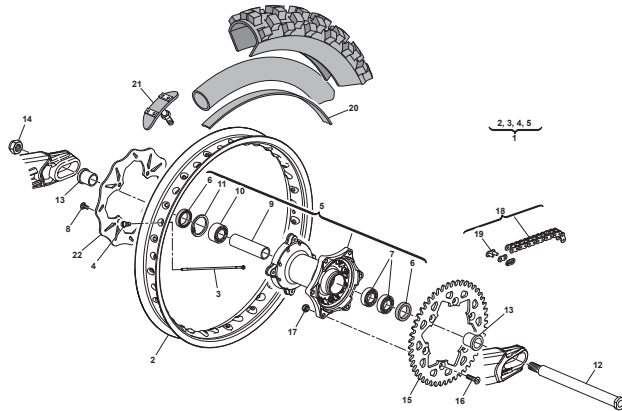

Pagina - Page - Page - Seite - Paja

98

Tavola - Drawing - Table - Bild - Tabla

39

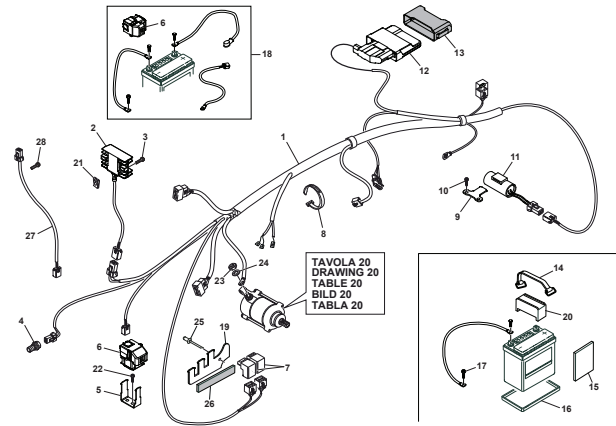

Pagina - Page - Page - Seite - Paja

100

Tavola - Drawing - Table - Bild - Tabla

40

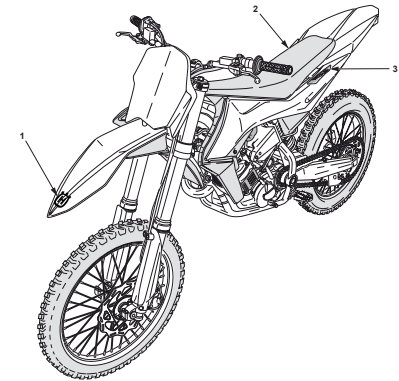

Pagina - Page - Page - Seite - Paja

102

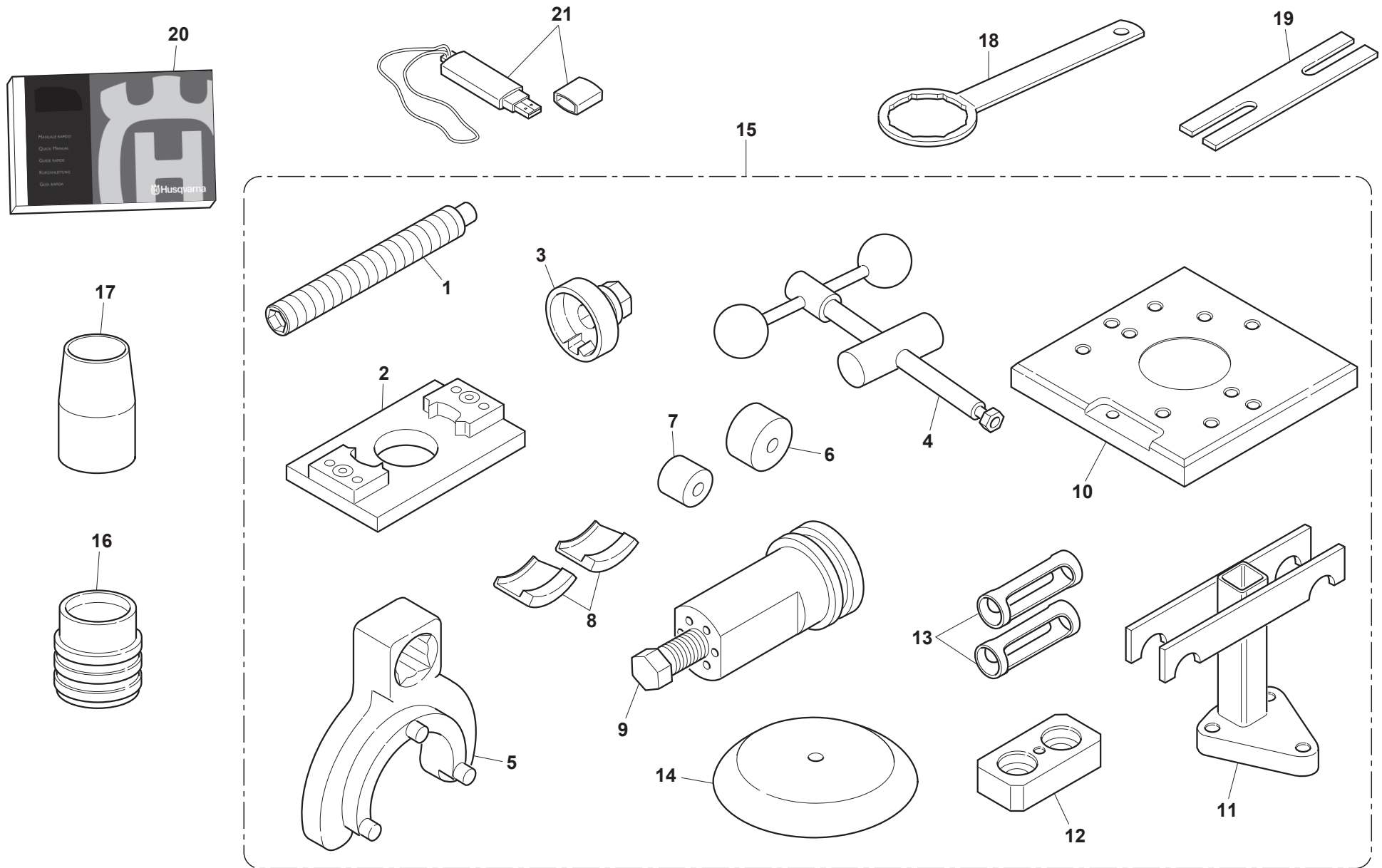

ATTREZZI DI ASSISTENZA, MANUALI E CATALOGHI - SERVICE TOOLS, MANUALS AND CATALOGS
OUTILS D'ASSISTANCE, MANUELS ET CATALOGUES - HILFAUSRUSTUNG, HANDBUCH UND KATALOG
HERRAMIENTAS DE ASISTENCIA, MANUALES Y CATALOGOS

TAVOLA - DRAWING
TABLE - BILD - TABLA

1

Note Notes Marke Notas	Pos. No. Index Pos.	N. Cod. Code No. Nr. Code Code Nr N. Cod.	Q.tà Q.ty M.ge C.ad	DENOMINAZIONE	NAME	DESIGNATION	BESHREIBUNG	DENOMINACION	Validità Validity Validité Gültig Validez
	1	8000H5009	1	VITE BLOCCAGGIO ALBERO MOTORE	SCREW, CRANKSHAFT LOCKING	VIS DE BLOCAGE VILEBREQUIN	SCHRAUBE, KURBELWELLENFESTSTELLUNG	TORNILLO BLOQUEO CIGUENAL	
	2	8000H5020	1	PIASTRA CONTROLLO LIMITATORE DI COPPIA	TORQUE LIMITER CHECK PLATE	PLAQUE DE CONTROLE LIMITEUR DE COUPLE	PLATTE FUR DREHZAHLBEGRENZERKONTROLLE	PLACA CONTROL LIMITADOR DE PAR	
	3	8000H5767	1	CHIAVE SPECIALE	KEY, SPECIAL	CLE SPECIAL	SPEZIAL SCHLUESSEL	LLAVE ESPECIAL	
	4	8000H5016	1	SPINGIMOLLE	SPRING PRESSER	PRESSE-RESSORTS	FEDERDRUCHSCHEIBE	PLATO DE PRESION MUELLES	
	5	8000H5010	1	CHIAVE BLOCCAGGIO INGRANAGGIO	GEAR LOCKING WRENCH	CLE DE BLOCAGE ENGRENAGE	ZAHNRADKLEMMSCHLUSSEL	LLAVE BLOQUEO ENGRANAJE	
	6	8000H5014	1	INSERTO PER PRESSIONE 25 MM	25 MM PRESSURE INSERT	INSERT POUR PRESSION 25 MM	DRUCKMESSEINSATZ 25 MM	INSERTO PARA PRESION 25 MM	
	7	8000H5013	1	INSERTO PER PRESSIONE 18 MM	18 MM PRESSURE INSERT	INSERT POUR PRESSION 18 MM	DRUCKMESSEINSATZ 18 MM	INSERTO PARA PRESION 18 MM	
	8	8000H5012	2	UNGHIE PER ESTRATTORE	PULLER CHISELS	ONGLETS POUR EXTRACTEUR	ABZIEHERKRALLEN	CARRIL PARA EXTRACTOR	
	9	8000H5011	1	ESTRATTORE	PULLER	EXTRACTEUR	ABZIEHER	EXTRACTOR	
	10	8000H5015	1	PIASTRA SUPPORTO SMONTAGGIO VALVOLE	VALVE DISASSEMBLY HOLDER PLATE	PLAQUE DE SUPPORT	AUFLAGEFLAECH FUR VENTILAUSBAU	PLACA SOPORTE PARA DESMONTAJE VALVULAS	
	11	8000H5017	1	SUPPORTO SMONTAGGIO VALVOLE	VALVE DISASSEMBLY SUPPORT	SUPPORT DEPOSE SOUPAPES	AUFLAGE FUR VENTILAUSBAU	SOPORTE DESMONTAJE VALVULAS	
	12	8000H5019	1	PIASTRA SPINGIMOLLE	SPRING PRESSURE PLATE	PLAQUE PRESSE-RESSORTS	FEDERDRUCKPLATTE	PLACA DISCO DE EMPUJE	
	13	8000H5018	2	GABBIA SPINGIMOLLE	SPRING PRESSURE CAGE	CAGE PRESSE-RESSORTS	FEDERDRUCKBUCHSE	JAULA DISCO DE EMPUJE	
	14	8000H5042	1	INSERTO	INSERT	INSERTION	EINSATZ	INSERTADO	
	15	8000H6080	1	GRUPPO ATTREZZI SPECIALI MOTORE	ENGINE SPECIAL TOOL KIT	GROUPE OUTILS SPECIAUX POUR MOTEUR	SPEZIALWERKZEUG GRUPPE FUR MOTOR	GRUPO HERRAMIENTAS ESPECIALES MOTOR	
	16	8000H5149	1	ATTREZZO MONTAGGIO PARAOLIO 48 MM	48 MM OIL SEAL DRIFT	OUTIL DE FIXATION JOINT D'HUILE 48 MM	SETZWERKZEUG FUR OLDICHRING 48 MM	HERRAMIENTA FIJACION RETEN 48 MM	
	17	8000H5150	1	ATTREZZO INSERIMENTO PARAOLIO 48 MM	48 MM OIL SEAL ASSEMBLING TOOL	OUTIL DE MONTAGE JOINT D'HUILE 48 MM	EINSETZWERKZEUG FUR OLDICHRING 48 MM	HERRAMIENTA INSERCIÓN RETEN 48 MM	
	18	8000H5151	1	CHIAVE TAPPO FODERO 49 MM	49 MM SLIDER PLUG KEY	CLE POUR BOUCHON FOURREAU 49 MM	SCHLUSSEL FUR GLEITROHRVERSCHLUSS 49 MM	LLAVE PARA TAPON BOTELLA 49 MM	
	19	8000H5152	1	ATTREZZO BLOCCAGGIO ASTA POMPANTE	DAMPER LOCKING TOOL	OUTIL DE BLOCAGE TIGE AMORTISSEUR	KLEMMWERKZEUG FUR PUMPELEMENTSTAB	HERRAMIENTA BLOQUEO VARILLA DE BOMBEO	
	20	8000H7606	1	MANUALE RAPIDO	QUICK MANUAL	GUIDE RAPIDE	KURZANLEITUNG	GUIA RAPIDA	
	21	8000H7607	1	CHIAVETTA USB	PENDRIVE USB	CLE' USB	USB MASSENSPEICKER-STICK	LLAVERO USB	
USA	21	8000H7575	1	CHIAVETTA USB	PENDRIVE USB	CLE' USB	USB MASSENSPEICKER-STICK	LLAVERO USB	

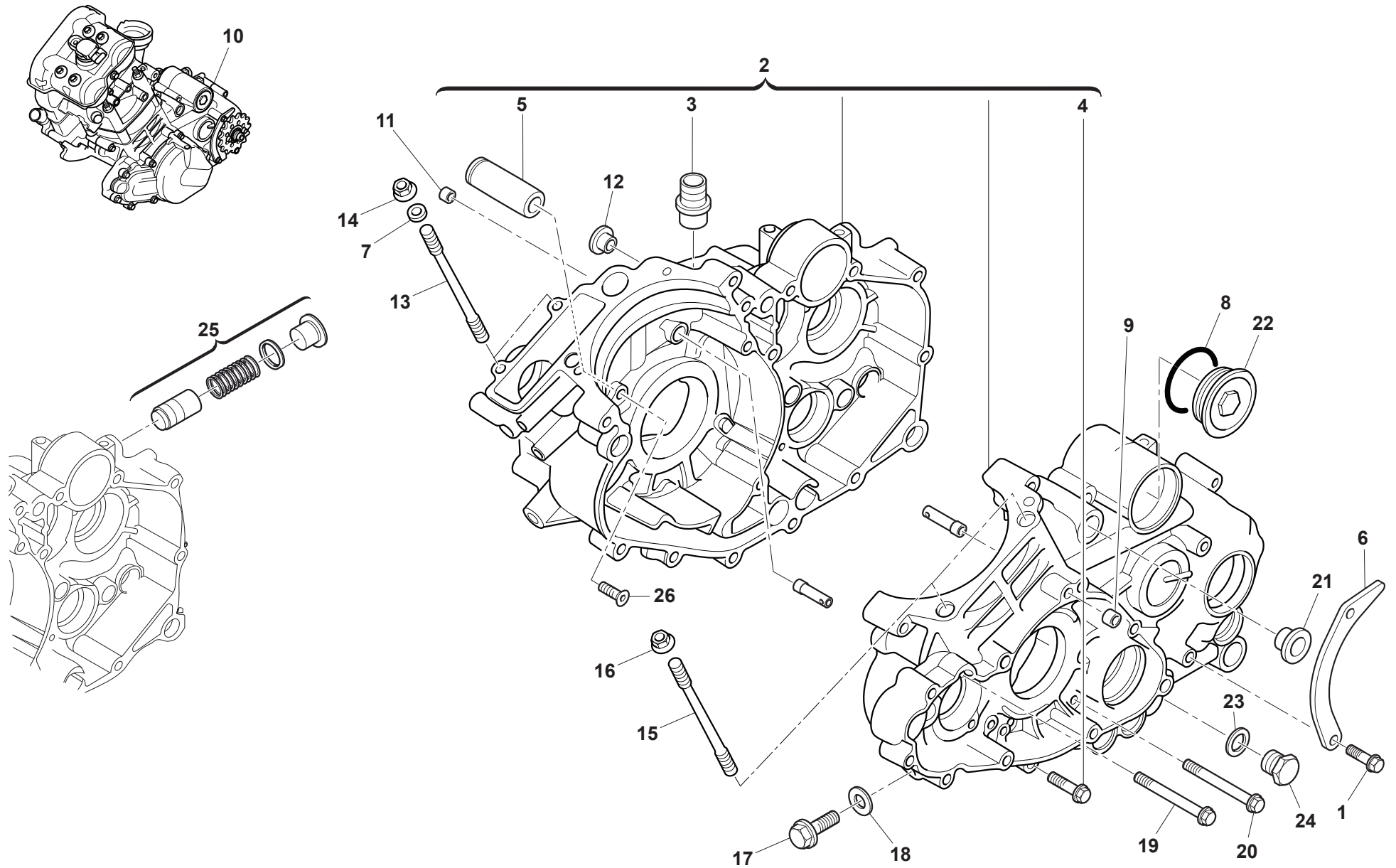

SEMICARTER 1/2 - HALF CRANKCASE 1/2
CARTER 1/2 - GEHAUSEDECKEL 1/2
BANCADA 1/2

TAVOLA - DRAWING
TABLE - BILD - TABLA

2

Note Notes Marke Notas	Pos. No. N. Index Pos.	N. Cod. Code No. Nr. Code Code Nr N. Cod.	Q.tà Q.ty Q.te M.ge C.ad	DENOMINAZIONE	NAME	DESIGNATION	BESHREIBUNG	DENOMINACION	Validità Validity Validité Gültig Validez
	1	Z00062727	2	VITE TE M6X1X16 CH8	SCREW TE M6X1X16 CH8	VIS TE M6X1X16 CH8	SCHRAUBE TE M6X1X16 CH8	TORNILLO TE M6X1X16 CH8	
	2	8527735	1	CARTER MOTORE	CRANKCASE SET	CARTER MOTEUR	KURBELWELLENGEHAUSE	CARTER MOTOR	
	3	7717725	1	RACCORDO SFIATO	JOINT, BREATHER	RACCORD, RENIFLARD	ROHR, BELUFTUNG	TUBO RESPIRADERO	
	4	7707165	12	VITE M6X50	SCREW M6X50	VIS M6X50	SCHRAUBE M6X50	TORNILLO M6X50	
	5	8520263	1	PERNO	PIN	PIVOT	BOLZEN	PERNO	
	6	8000H4771	1	GUIDACATENA	GUIDE, CHAIN	GUIDE CHAINE	KETTENFUEHRUNG	GUIA CADENA	
	7	9905990	2	RONDELLA	WASHER	RONDELLE	SCHEIBE	ARANDELA	
	8	9906611	1	ANELLO O-RING	O-RING	JOINT TORIQUE	O-RING	JUNTA TORICA	
	9	7727538	1	GETTO OLIO 2,5 MM	JET, OIL 2,5 MM	GICLEUR HUILE 2,5 MM	OELDUESE 2,5 MM	CHICLE' ACEITE 2,5 MM	
	10	8000H6670	1	MOTORE	ENGINE	MOTEUR	MOTOR	MOTOR	
	11	7719441	1	RACCORDO	JOINT	RACCORD	ANSCHLUSS	EMPALME	
	12	8521139	1	BOCCOLA	BUSH	DOUILLE	BUCHSE	BUJE	
	13	7707008	2	PRIGIONIERO	BOLT, STUD	GOUJON	STIFTSCHRAUBE	ESPARRAGO	
	14	9904882	2	DADO	NUT	ECROU	MUTTER	TUERCA	
	15	7707006	4	PRIGIONIERO	BOLT, STUD	GOUJON	STIFTSCHRAUBE	ESPARRAGO	
	16	7707007	4	DADO	NUT	ECROU	MUTTER	TUERCA	
	17	7706412	1	VITE M8X16	SCREW M8X16	VIS M8X16	SCHRAUBE M8X16	TORNILLO M8X16	
	18	7707109	1	RONDELLA 8X16X1,6 AL	WASHER 8X16X1,6 AL	RONDELLE 8X16X1,6 AL	DICHTSCHEIBE 8X16X1,6 AL	ARANDELA 8X16X1,6 AL	
	19	7707167	1	VITE M6X75	SCREW M6X75	VIS M6X75	SCHRAUBE M6X75	TORNILLO M6X75	
	20	7707166	2	VITE M6X70	SCREW M6X70	VIS M6X70	SCHRAUBE M6X70	TORNILLO M6X70	
	21	7713164	1	BOCCOLA	BUSH	DOUILLE	BUCHSE	BUJE	
	22	7707101	1	COPERCHIO FILTRO OLIO	COVER, OIL ELEMENT	COUVERCLE FILTRE A HUILE	DECKEL, OELFILTER	CUBIERTA FILTRO ACEITE	
	23	9963252	1	RONDELLA ALLUMINIO	WASHER, ALUMINIUM	RONDELLE EN ALUMINIUM	ALUMINIUM SCHEIBE	ARANDELA ALUMINIO	
	24	7717724	1	VITE MAGNETICA M16	SCREW, MAGNETIC M16	VIS MAGNETIQUE M16	MAGNETISCH SCHRAUBE M16	TORNILLO MAGNETICO M16	
	25	7707102	1	VALVOLA SOVRAPRESSIONE OLIO	VALVE, OIL PRESSURE RELIEF	SOUPAPE SURPRESSION HUILE	OELUEBERDRUCKVENTIL	VALVULA SOBREPRESION ACEITE	
	26	7719439	26	VITE	SCREW	VIS	SCHRAUBE	TORNILLO	



TAVOLA 2
DRAWING 2
TABLE 2
BILD 2
TABLA 2

TAVOLA 2
DRAWING 2
TABLE 2
BILD 2
TABLA 2



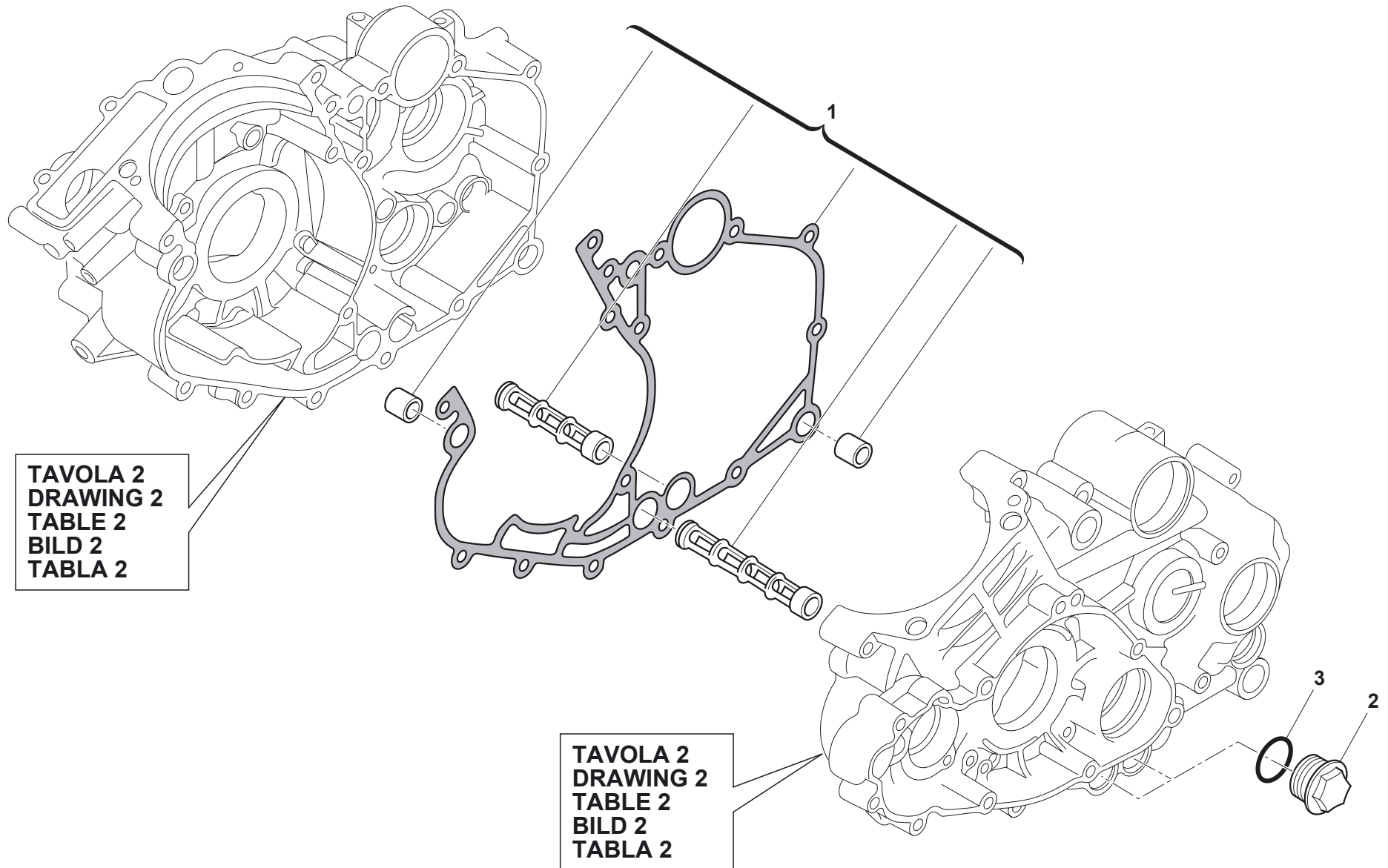
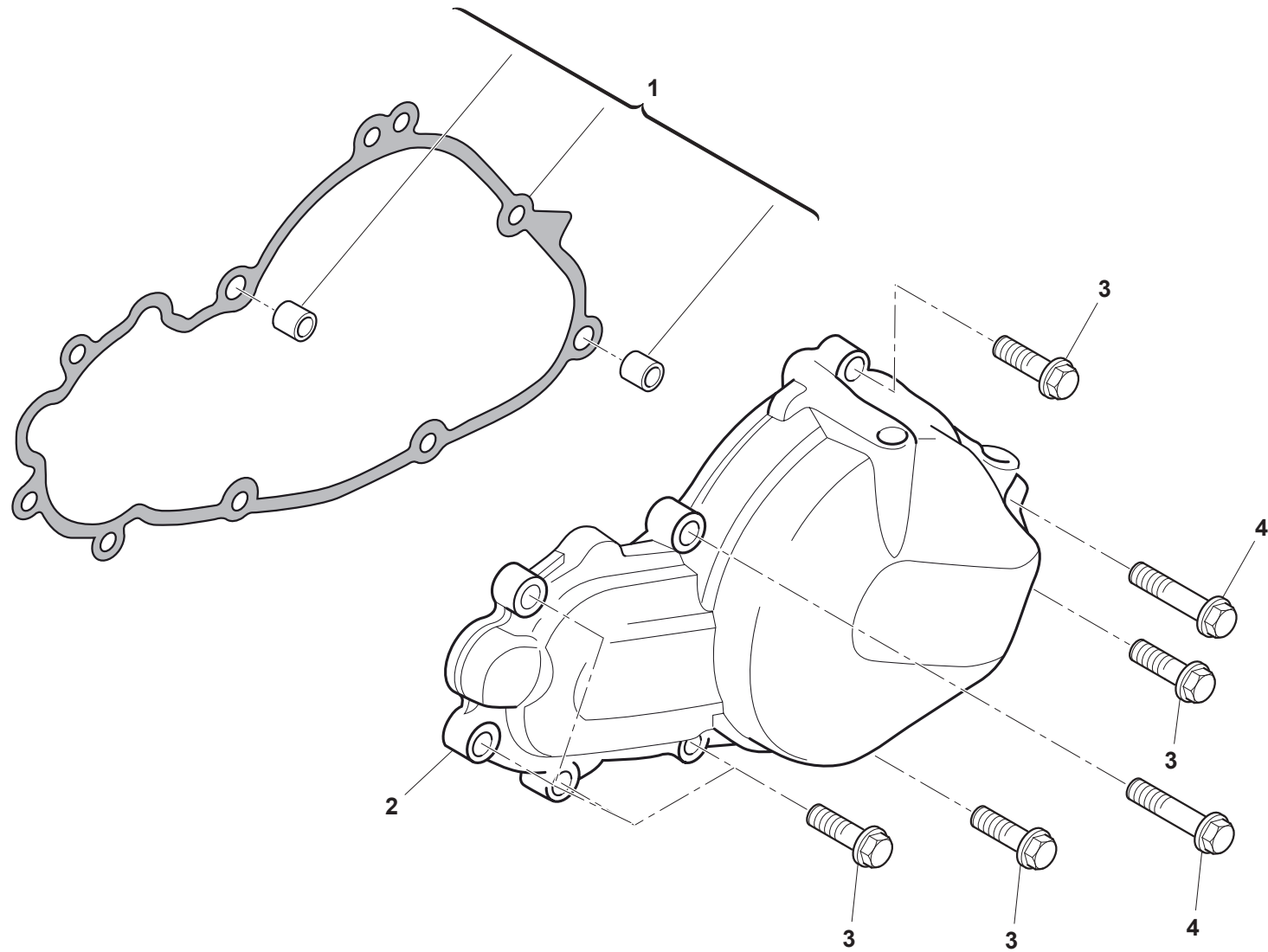
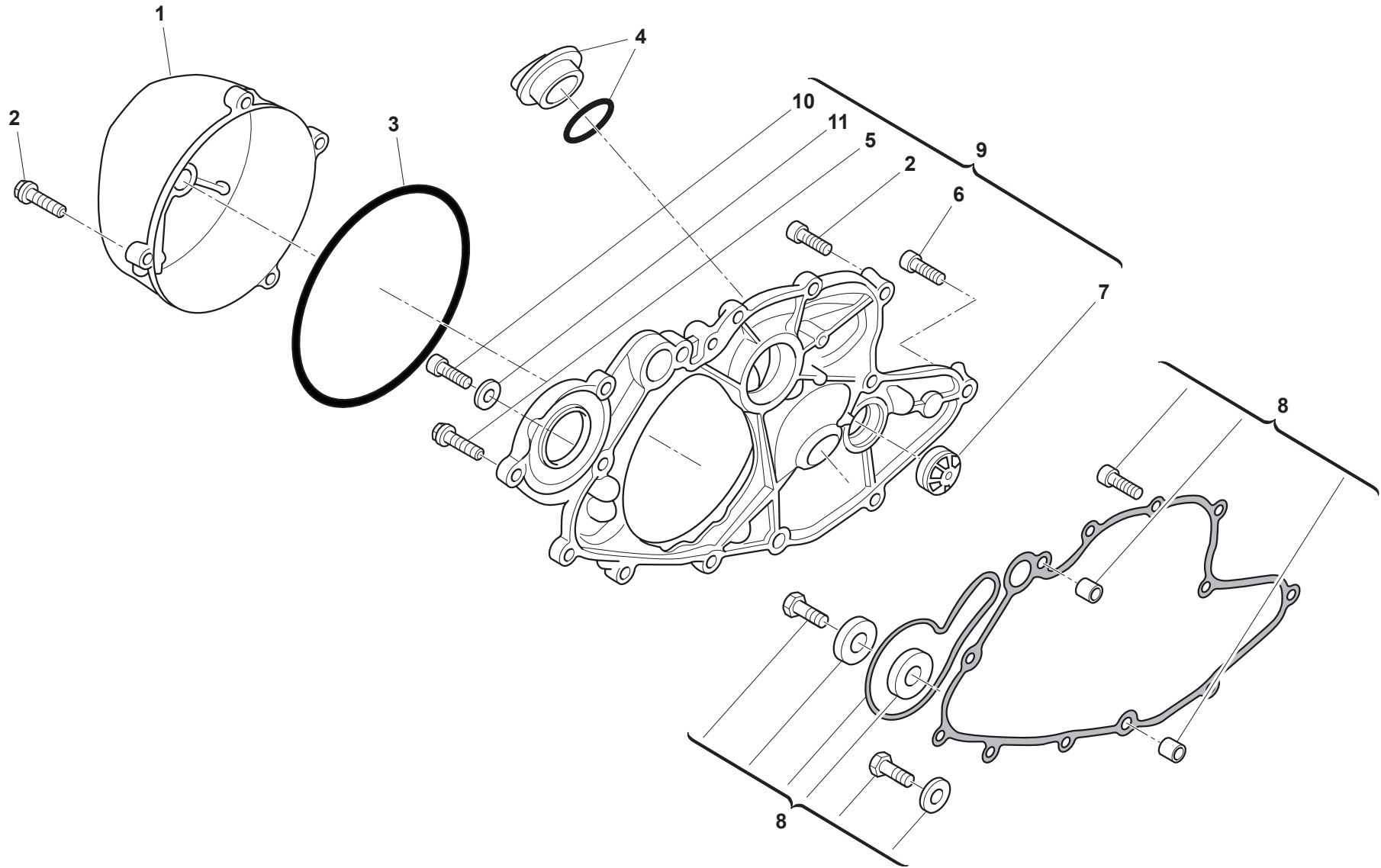

**COPERCHI SEMICARTER DX - R.H. HALF CRANKCASE
COVERS COUVERCLES CARTER D. - GEHAUSEDECKEL R.
TAPAS BANCADA DER.**



Note Notes Marke Notas	Pos. No. N. Index Pos.	N. Cod. Code No. Nr. Code Code Nr N. Cod.	Q.tà Q.ty M.ge C.ad	DENOMINAZIONE	NAME	DESIGNATION	BESHREIBUNG	DENOMINACION	Validità Validity Validité Gültig Validez
	1	7729380	1	COPERCHIO FRIZIONE ESTERNO	CLUTCH COVER, OUTER	COUVERCLE EMBRAYAGE EXTERIEUR	AUSSEREKUPPLUNGSDECKEL	CUBIERTA EMBRAGUE EXTERIOR	
	2	7707183	6	VITE M6X25	SCREW M6X25	VIS M6X25	SCHRAUBE M6X25	TORNILLO M6X25	
	3	7707126	1	GUARNIZIONE COPERCHIO FRIZIONE ESTERNO	GASKET, CLUTCH COVER OUTER	JOINT COUVERCLE EMBRAYAGE EXTERIEUR	DICHTUNG, AUSSEREKUPPLUNGSDECKEL	JUNTA CUBIERTA EMBRAGUE EXTERIOR	
	4	7715430	1	TAPPO ALIMENTAZIONE OLIO	CAP, OIL FILLER	BOUCHON REMPLISSEMENT HUILE	STOEPSSEL OELEINFUELL	TAPON INTRUDUCCION ACEITE	
	5	7707184	1	VITE M6X30	SCREW M6X30	VIS M6X30	SCHRAUBE M6X30	TORNILLO M6X30	
	6	7726674	3	VITE TCEI M6X16	SCREW TCEI M6X16	VIS TCEI M6X16	SCHRAUBE TCEI M6X16	TORNILLO TCEI M6X16	
	7	7707100	1	VETRINO SPIA LIVELLO OLIO	WINDOW, OIL LEVEL CHECK	HUBLOT NIVEAU HUILE	SCHAUGLAS, OELKONTROLL	MIRILLA NIVEL ACEITE	
	8	7715428	1	GUARNIZIONE COPERCHIO FRIZIONE	GASKET, CLUTCH COVER	JOINT COUVERCLE EMBRAYAGE	DICHTUNG KUPPLUNGSDECKEL	JUNTA CUBIERTA EMBRAGUE	
	9	8527744	1	COPERCHIO FRIZIONE	COVER, CLUTCH	COUVERCLE EMBRAYAGE	KUPPLUNGSDECKEL	CUBIERTA EMBRAGUE	
	10	9906627	1	VITE	SCREW	VIS	SCHRAUBE	TORNILLO	
	11	9963037	1	GUARNIZIONE	GASKET	JOINT	DICHTUNG	JUNTA	

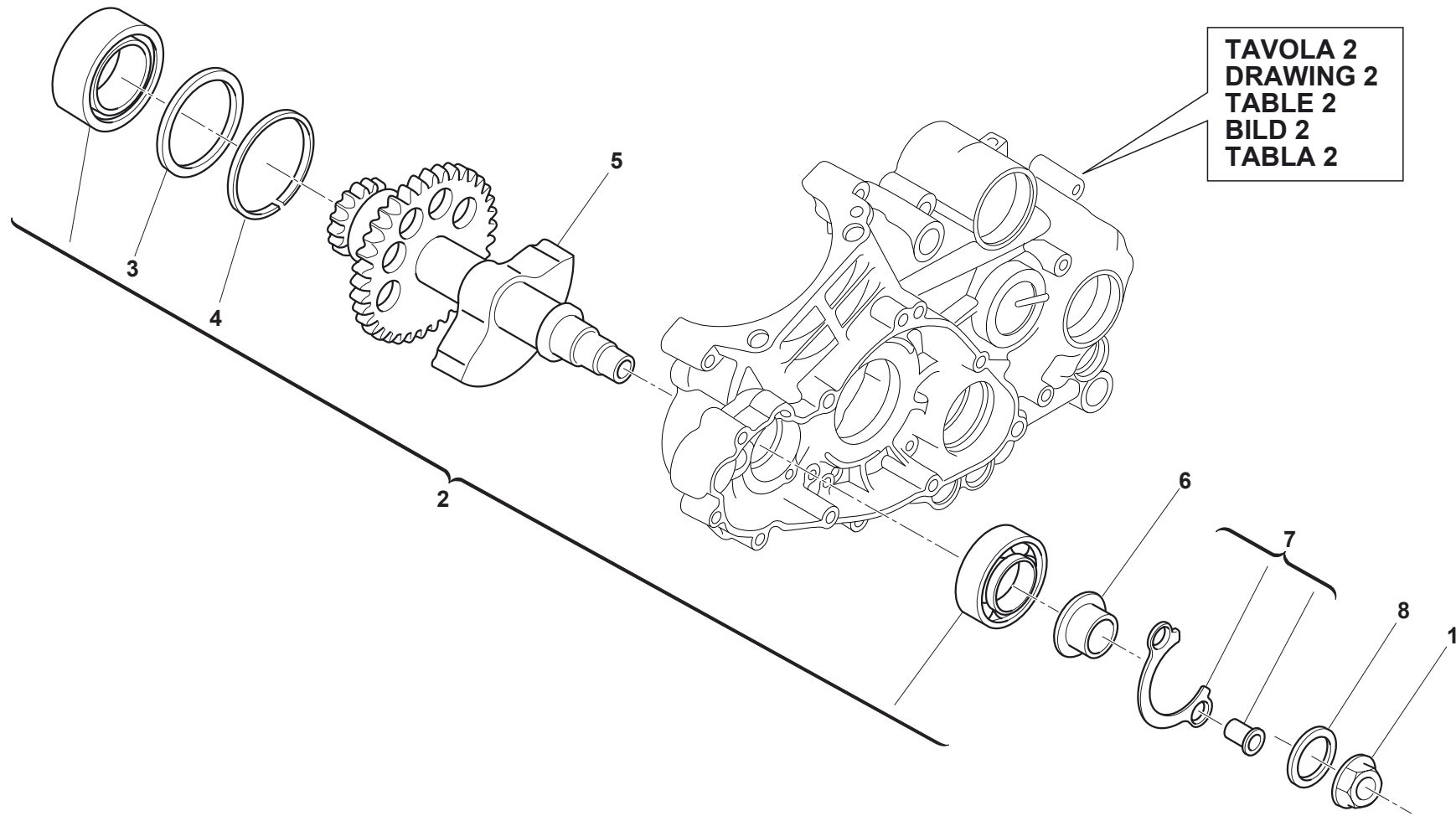

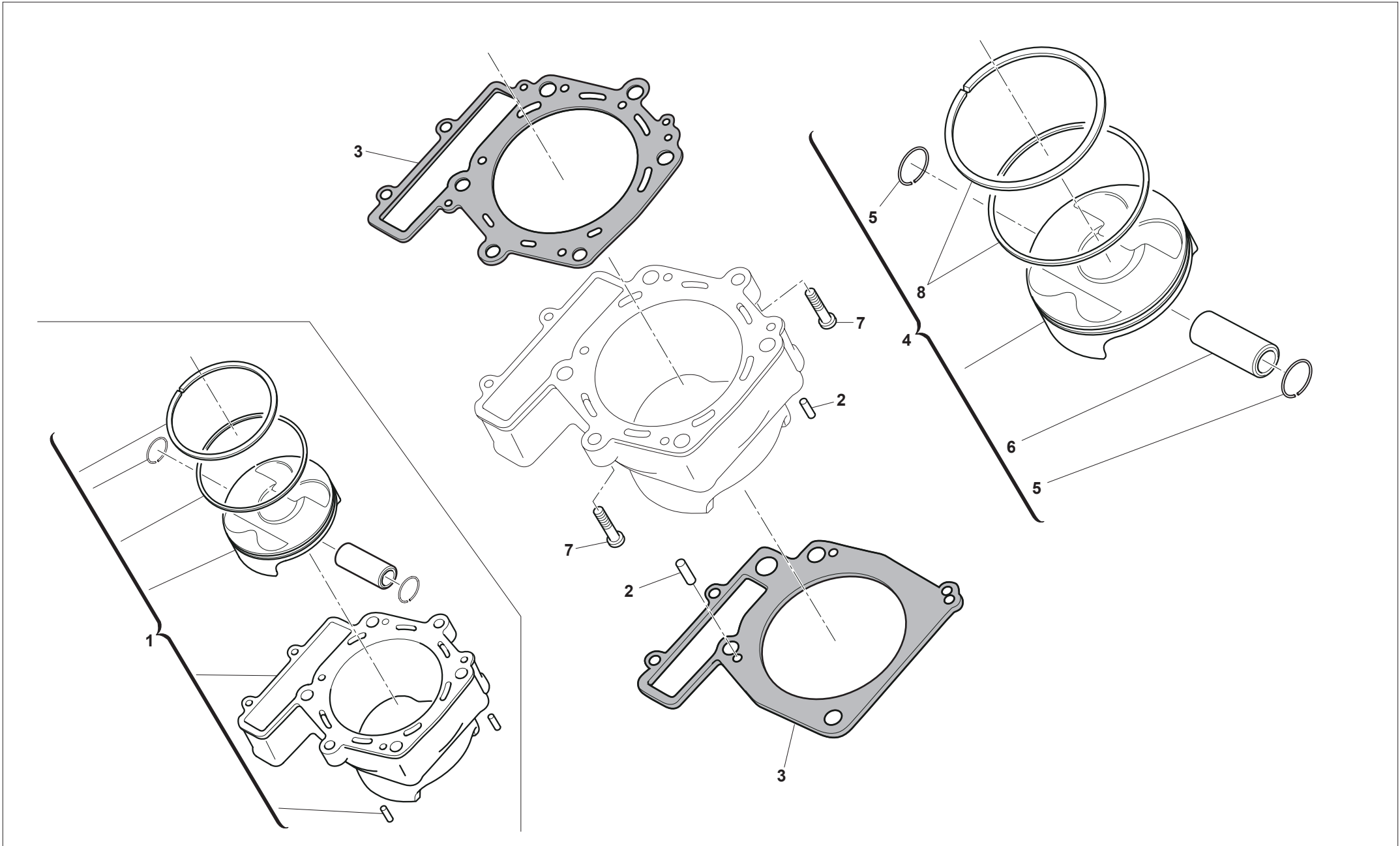



TAVOLA 8
DRAWING 8
TABLE 8
BILD 8
TABLA 8





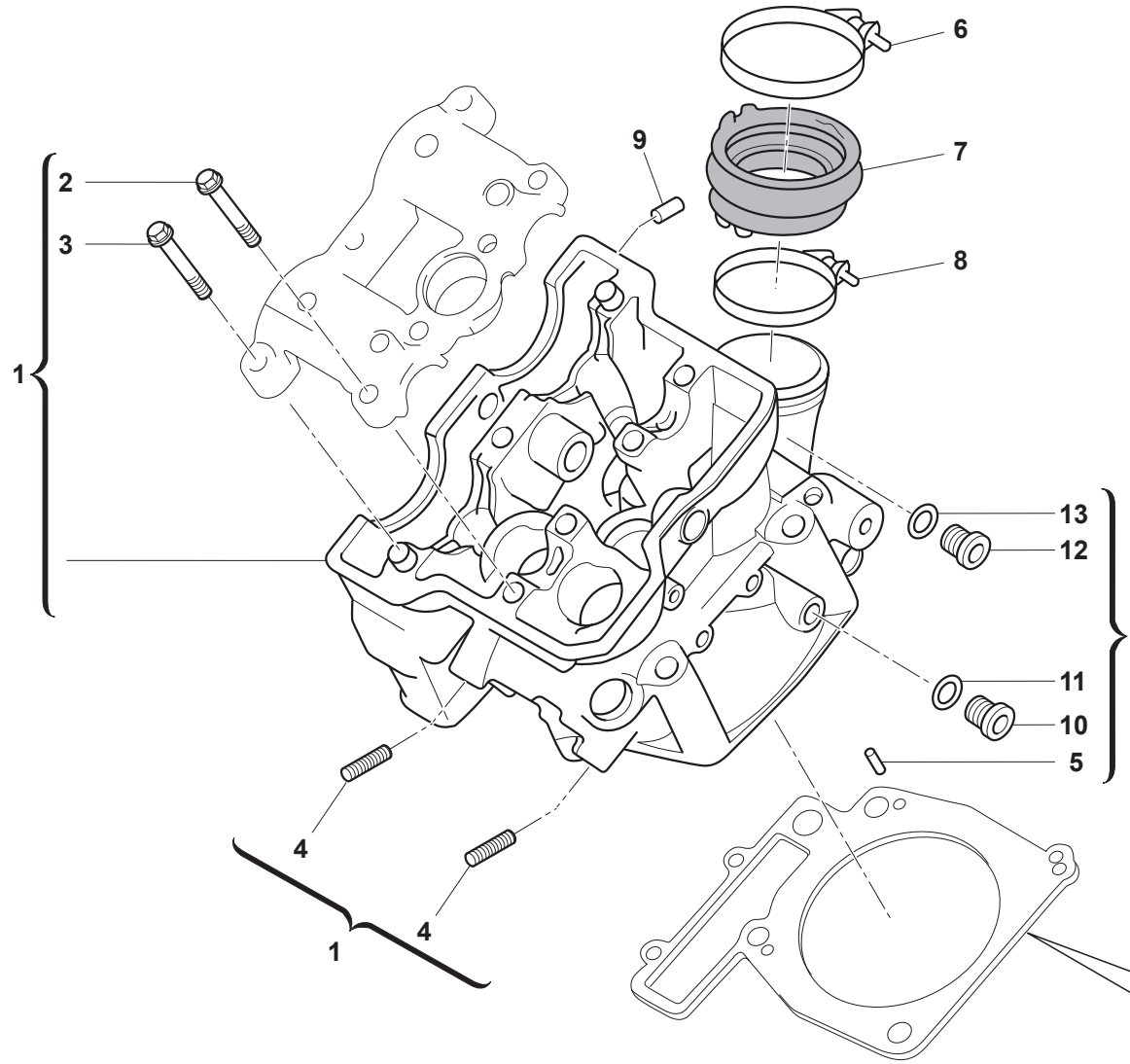
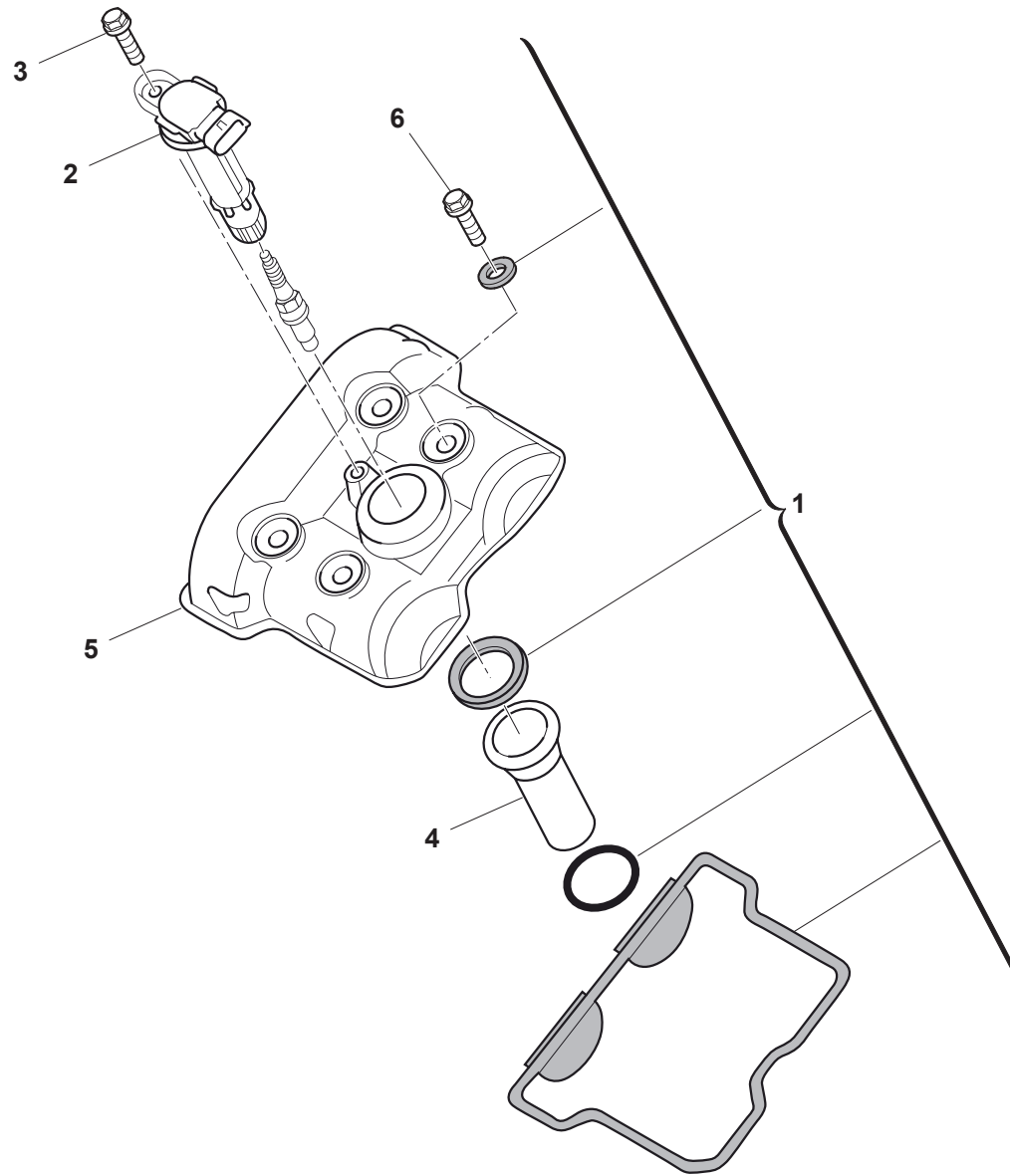
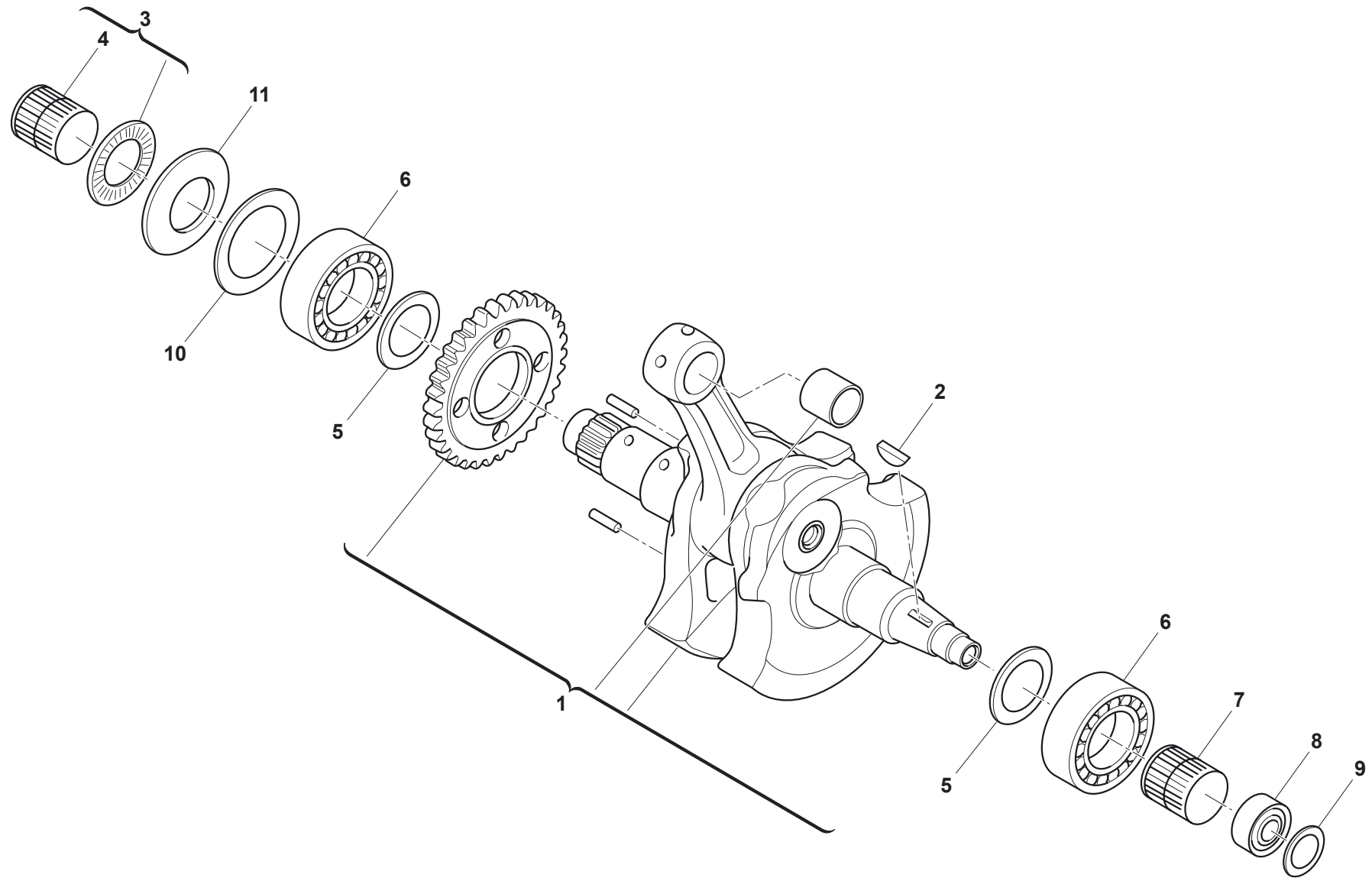

TAVOLA 6
DRAWING 6
TABLE 6
BILD 6
TABLA 6



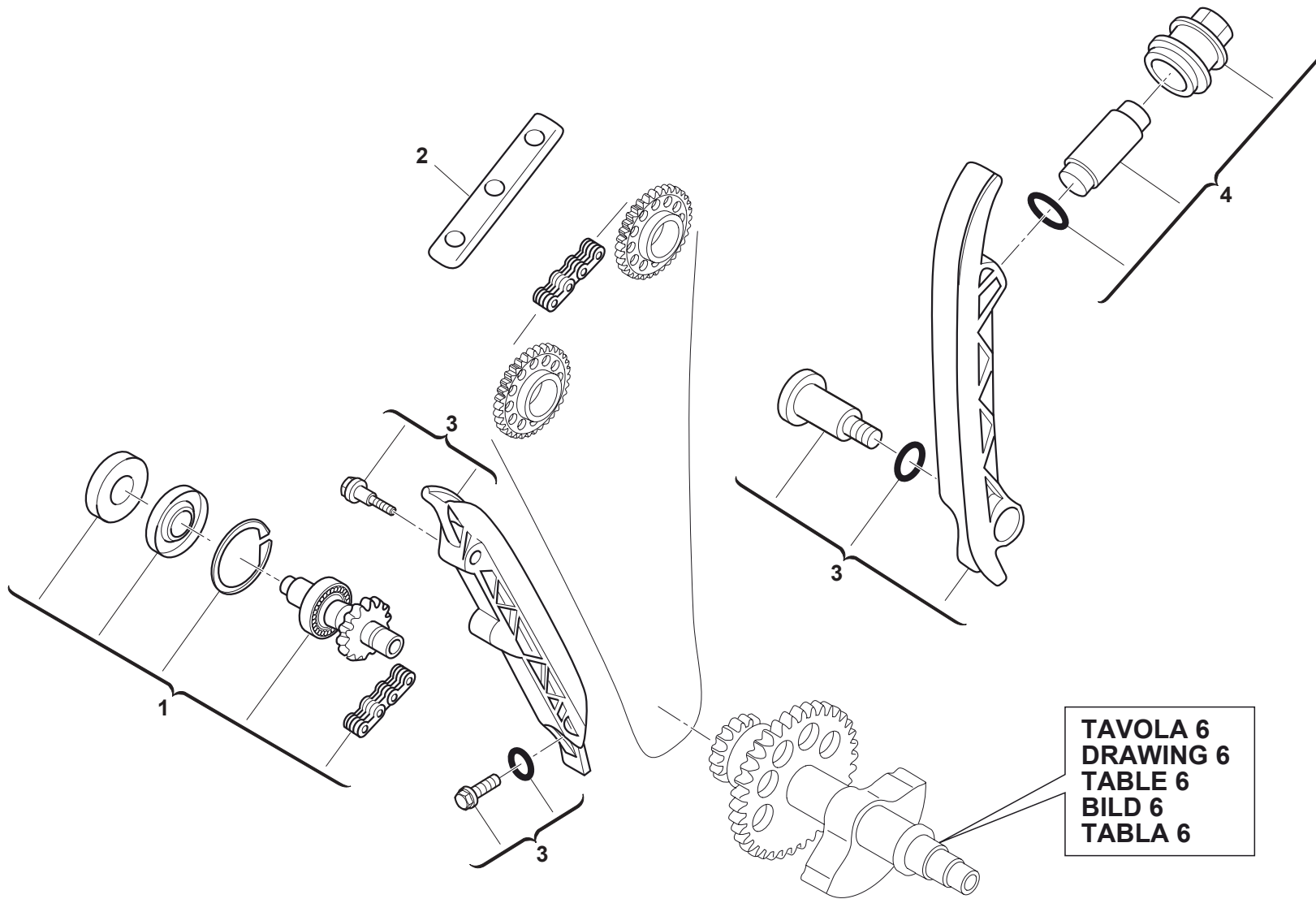
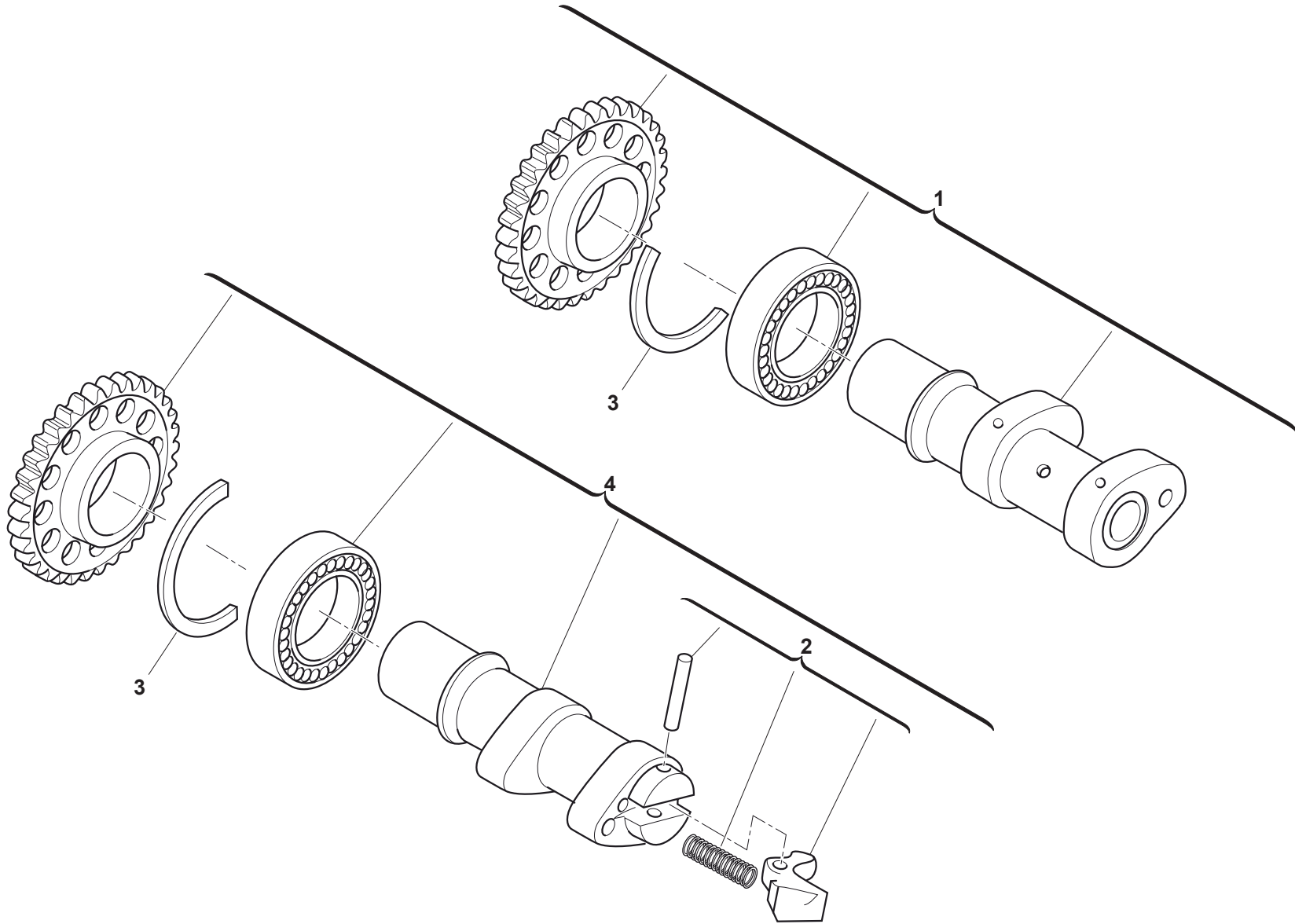

TAVOLA 9
DRAWING 9
TABLE 9
BILD 9
TABLA 9

VALVOLA ASPIRAZIONE-SCARICO - INLET-EXHAUST VALVE
SOUPAPE ADMISSION-D'ECHAPPEMENT - EINLASS-AUSLASS VENTIL
VÁLVULA ASPIRACIÓN-DE ESCAPE

TAVOLA - DRAWING
TABLE - BILD - TABLA

14

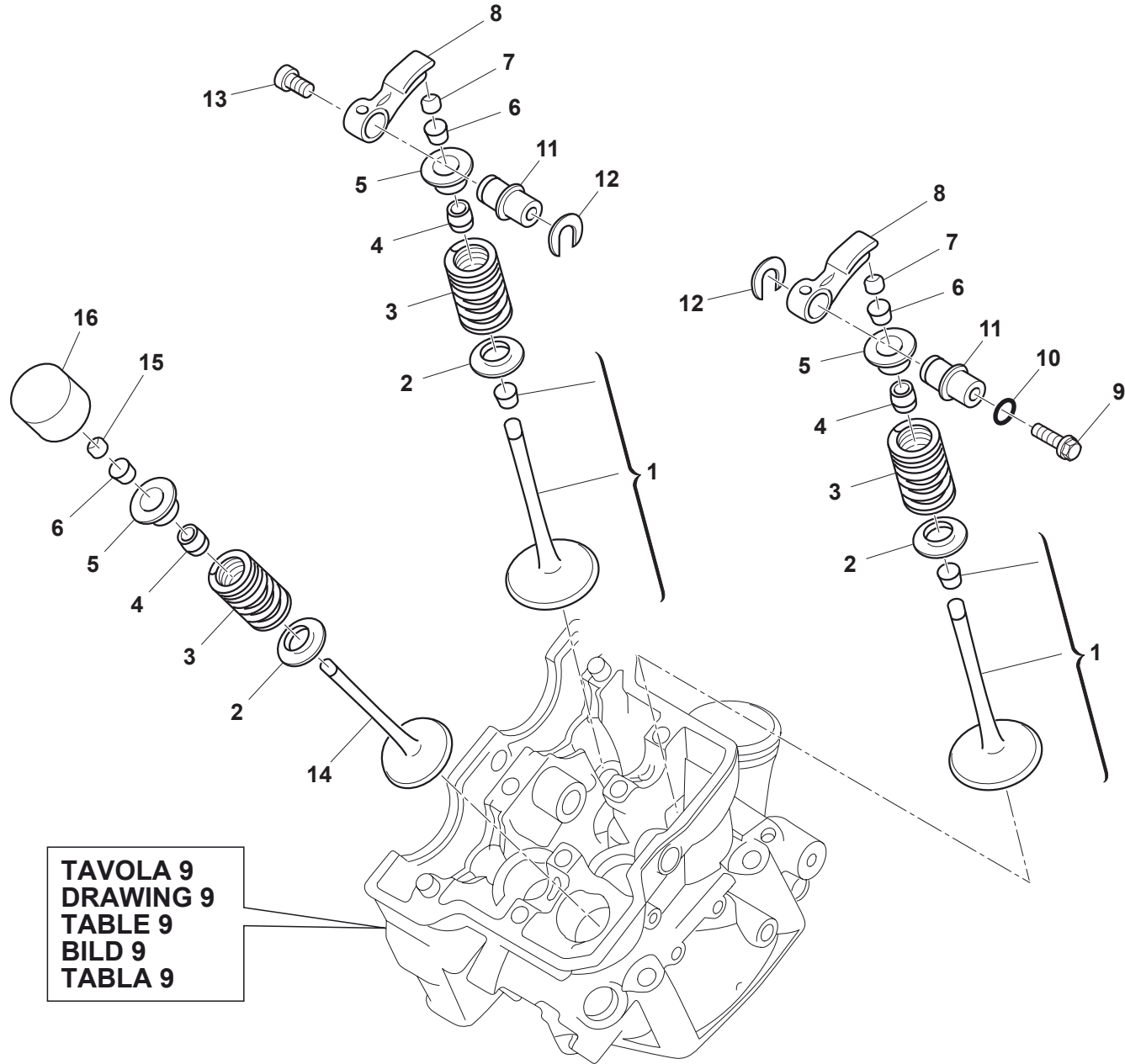
Note Notes Marke Notas	Pos. No. Index Pos.	N. Cod. Code No. Nr. Code Code Nr N. Cod.	Q.tà Q.ty M.ge C.ad	DENOMINAZIONE	NAME	DESIGNATION	BESHREIBUNG	DENOMINACION	Validità Validity Validité Gültig Validez
	1	7724767	1	VALVOLA ASPIRAZIONE	VALVE, INTAKE	SOUPAPE ADMISSION	EINLASSVENTIL	VALVULAADMISION	
	2	7706961	4	SEDE MOLLA VALVOLA	SEAT, VALVE SPRING	SIEGE, RESSORT SOUPAPE	SITZ, VENTILFEDER	ASIENTO MUELLE VALVULA	
	3	7716275	4	MOLLA VALVOLA	SPRING, VALVE	RESSORT SOUPAPE	VENTILFEDER	MUELLE PARA VALVULA	
	4	1461679	4	PARAOLIO VALVOLA	SEAL, VALVE STEM	BAGUE D'ETANCHEITE GUIDE-SOUPAPE	VENTILSCHFTDICHTUNG	RETEN ACEITE GUIA VALVULA	
	5	7706964	4	SCODELLINO MOLLA VALVOLA	RETAINER, VALVE SPRING	FIXATION RESSORT SUPAPE	HALTER, VENTILFEDER	RETEN FIJO, RESORTE VALVULA	
	6	7706965	8	SEMICONO	COTTER, VALVE	CLAVETTE SOUPAPE	VENTILKEIL	SEGURO VALVULA	
	7	7676535	2	SEMISFERA 5,60 MM	HALFBALL 5.60 MM	DEMIBILLE 5,60 MM	HALBKUGEL 5,60 MM	SEMIESFERA 5,60 MM	
	7	7676527	2	SEMISFERA 5,20 MM	HALFBALL 5.20 MM	DEMIBILLE 5,20 MM	HALBKUGEL 5,20 MM	SEMIESFERA 5,20 MM	
	7	7676528	2	SEMISFERA 5,25 MM	HALFBALL 5.25 MM	DEMIBILLE 5,25 MM	HALBKUGEL 5,25 MM	SEMIESFERA 5,25 MM	
	7	7676529	2	SEMISFERA 5,30 MM	HALFBALL 5.30 MM	DEMIBILLE 5,30 MM	HALBKUGEL 5,30 MM	SEMIESFERA 5,30 MM	
	7	7676530	2	SEMISFERA 5,35 MM	HALFBALL 5.35 MM	DEMIBILLE 5,35 MM	HALBKUGEL 5,35 MM	SEMIESFERA 5,35 MM	
	7	7676537	2	SEMISFERA 5,70 MM	HALFBALL 5.70 MM	DEMIBILLE 5,70 MM	HALBKUGEL 5,70 MM	SEMIESFERA 5,70 MM	
	7	7676532	2	SEMISFERA 5,45 MM	HALFBALL 5.45 MM	DEMIBILLE 5,45 MM	HALBKUGEL 5,45 MM	SEMIESFERA 5,45 MM	
	7	7676534	2	SEMISFERA 5,55 MM	HALFBALL 5.55 MM	DEMIBILLE 5,55 MM	HALBKUGEL 5,55 MM	SEMIESFERA 5,55 MM	
	7	7676536	2	SEMISFERA 5,65 MM	HALFBALL 5.65 MM	DEMIBILLE 5,65 MM	HALBKUGEL 5,65 MM	SEMIESFERA 5,65 MM	
	7	7676526	2	SEMISFERA 5,15 MM	HALFBALL 5.15 MM	DEMIBILLE 5,15 MM	HALBKUGEL 5,15 MM	SEMIESFERA 5,15 MM	
	7	7676531	2	SEMISFERA 5,40 MM	HALFBALL 5.40 MM	DEMIBILLE 5,40 MM	HALBKUGEL 5,40 MM	SEMIESFERA 5,40 MM	
	7	7676524	2	SEMISFERA 5,05 MM	HALFBALL 5.05 MM	DEMIBILLE 5,05 MM	HALBKUGEL 5,05 MM	SEMIESFERA 5,05 MM	
	7	7676523	2	SEMISFERA 5,00 MM	HALFBALL 5.00 MM	DEMIBILLE 5,00 MM	HALBKUGEL 5,00 MM	SEMIESFERA 5,00 MM	
	7	7676522	2	SEMISFERA 4,95 MM	HALFBALL 4.95 MM	DEMIBILLE 4,95 MM	HALBKUGEL 4,95 MM	SEMIESFERA 4,95 MM	
	7	7676521	2	SEMISFERA 4,90 MM	HALFBALL 4.90 MM	DEMIBILLE 4,90 MM	HALBKUGEL 4,90 MM	SEMIESFERA 4,90 MM	
	7	7676520	2	SEMISFERA 4,85 MM	HALFBALL 4.85 MM	DEMIBILLE 4,85 MM	HALBKUGEL 4,85 MM	SEMIESFERA 4,85 MM	
	7	7676519	2	SEMISFERA 4,80 MM	HALFBALL 4.80 MM	DEMIBILLE 4,80 MM	HALBKUGEL 4,80 MM	SEMIESFERA 4,80 MM	
	7	7676518	2	SEMISFERA 4,75 MM	HALFBALL 4.75 MM	DEMIBILLE 4,75 MM	HALBKUGEL 4,75 MM	SEMIESFERA 4,75 MM	
	7	7676517	2	SEMISFERA 4,70 MM	HALFBALL 4.70 MM	DEMIBILLE 4,70 MM	HALBKUGEL 4,70 MM	SEMIESFERA 4,70 MM	
	7	7676516	2	SEMISFERA 4,65 MM	HALFBALL 4.65 MM	DEMIBILLE 4,65 MM	HALBKUGEL 4,65 MM	SEMIESFERA 4,65 MM	
	7	7676515	2	SEMISFERA 4,60 MM	HALFBALL 4.60 MM	DEMIBILLE 4,60 MM	HALBKUGEL 4,60 MM	SEMIESFERA 4,60 MM	
	7	7676533	2	SEMISFERA 5,50 MM	HALFBALL 5.50 MM	DEMIBILLE 5,50 MM	HALBKUGEL 5,50 MM	SEMIESFERA 5,50 MM	
	7	7676525	2	SEMISFERA 5,10 MM	HALFBALL 5.10 MM	DEMIBILLE 5,10 MM	HALBKUGEL 5,10 MM	SEMIESFERA 5,10 MM	
	8	7711887	2	BILANCIERE VALVOLA	ARM VALVE ROCKER	CULBUTEUR SOUPAPE	KIPPHEBEL, VENTIL	BALANCIN VALVULA	
	9	7706978	1	VITE M6	SCREW M6	VIS M6	SCHRAUBE M6	TORNILLO M6	
	10	9906614	1	ANELLO O-RING 9X1,5	O-RING 9X1.5	JOINT TORIQUE 9X1,5	O-RING 9X1,5	JUNTA TORICA 9X1,5	
	11	7706977	2	ASSE BILANCIERE VALVOLA	AXLE, VALVE ROCKER ARM	AXE CULBUTEUR	ACHSE, KIPPHEBEL	EJE BALANCIN	

VALVOLA ASPIRAZIONE-SCARICO - INLET-EXHAUST VALVE
SOUPAPE ADMISSION-D'ECHAPPEMENT - EINLASS-AUSLASS VENTIL
VÁLVULA ASPIRACIÓN-DE ESCAPE

TAVOLA - DRAWING
TABLE - BILD - TABLA

14

Note Notes Marke Notas	Pos. No. Index Pos.	N. Cod. Code No. Nr. Code Code Nr N. Cod.	Q.tà Q.ty Q.te M.ge C.ad	DENOMINAZIONE	NAME	DESIGNATION	BESHREIBUNG	DENOMINACION	Validità Validity Validité Gültig Validez
	12	9932872	2	ANELLO ELASTICO	SPRING RING	ANNEAU ARRET	SPRENGRING	ANILLO RETENCION	
	13	9906625	1	VITE M6X16	SCREW M6X16	VIS M6X16	SCHRAUBE M6X16	TORNILLO M6X16	
	14	7706967	2	VALVOLA SCARICO	VALVE, EXHAUST	SOUPAPE ECHAPPEMENT	AUSLASSVENTIL	VALVULA ESCAPE	
	15	7675719	2	PASTIGLIA VALVOLA 2,70 MM	PAD, VALVE ADJUSTING 2.70 MM	PASTILLE REGLAGE CULBETEUR 2,70 MM	VENTILKAEPPOCHEN 2,70 MM	REGISTRO BALANCIN 2,70 MM	
	15	7675785	2	PASTIGLIA VALVOLA 2,95 MM	PAD, VALVE ADJUSTING 2.95 MM	PASTILLE REGLAGE CULBETEUR 2,95 MM	VENTILKAEPPOCHEN 2,95 MM	REGISTRO BALANCIN 2,95 MM	
	15	7675783	2	PASTIGLIA VALVOLA 2,90 MM	PAD, VALVE ADJUSTING 2.90 MM	PASTILLE REGLAGE CULBETEUR 2,90 MM	VENTILKAEPPOCHEN 2,90 MM	REGISTRO BALANCIN 2,90 MM	
	15	7675781	2	PASTIGLIA VALVOLA 2,85 MM	PAD, VALVE ADJUSTING 2.85 MM	PASTILLE REGLAGE CULBETEUR 2,85 MM	VENTILKAEPPOCHEN 2,85 MM	REGISTRO BALANCIN 2,85 MM	
	15	7675779	2	PASTIGLIA VALVOLA 2,80 MM	PAD, VALVE ADJUSTING 2.80 MM	PASTILLE REGLAGE CULBETEUR 2,80 MM	VENTILKAEPPOCHEN 2,80 MM	REGISTRO BALANCIN 2,80 MM	
	15	7675711	2	PASTIGLIA VALVOLA 2,50 MM	PAD, VALVE ADJUSTING 2.50 MM	PASTILLE REGLAGE CULBETEUR 2,50 MM	VENTILKAEPPOCHEN 2,50 MM	REGISTRO BALANCIN 2,50 MM	
	15	7675777	2	PASTIGLIA VALVOLA 2,75 MM	PAD, VALVE ADJUSTING 2.75 MM	PASTILLE REGLAGE CULBETEUR 2,75 MM	VENTILKAEPPOCHEN 2,75 MM	REGISTRO BALANCIN 2,75 MM	
	15	7675787	2	PASTIGLIA VALVOLA 3,00 MM	PAD, VALVE ADJUSTING 3.00 MM	PASTILLE REGLAGE CULBETEUR 3,00 MM	VENTILKAEPPOCHEN 3,00 MM	REGISTRO BALANCIN 3,00 MM	
	15	7675713	2	PASTIGLIA VALVOLA 2,55 MM	PAD, VALVE ADJUSTING 2.55 MM	PASTILLE REGLAGE CULBETEUR 2,55 MM	VENTILKAEPPOCHEN 2,55 MM	REGISTRO BALANCIN 2,55 MM	
	15	7675709	2	PASTIGLIA VALVOLA 2,45 MM	PAD, VALVE ADJUSTING 2.45 MM	PASTILLE REGLAGE CULBETEUR 2,45 MM	VENTILKAEPPOCHEN 2,45 MM	REGISTRO BALANCIN 2,45 MM	
	15	7675707	2	PASTIGLIA VALVOLA 2,40 MM	PAD, VALVE ADJUSTING 2.40 MM	PASTILLE REGLAGE CULBETEUR 2,40 MM	VENTILKAEPPOCHEN 2,40 MM	REGISTRO BALANCIN 2,40 MM	
	15	7675542	2	PASTIGLIA VALVOLA 2,35 MM	PAD, VALVE ADJUSTING 2.35 MM	PASTILLE REGLAGE CULBETEUR 2,35 MM	VENTILKAEPPOCHEN 2,35 MM	REGISTRO BALANCIN 2,35 MM	
	15	7675540	2	PASTIGLIA VALVOLA 2,30 MM	PAD, VALVE ADJUSTING 2.30 MM	PASTILLE REGLAGE CULBETEUR 2,30 MM	VENTILKAEPPOCHEN 2,30 MM	REGISTRO BALANCIN 2,30 MM	
	15	7675715	2	PASTIGLIA VALVOLA 2,60 MM	PAD, VALVE ADJUSTING 2.60 MM	PASTILLE REGLAGE CULBETEUR 2,60 MM	VENTILKAEPPOCHEN 2,60 MM	REGISTRO BALANCIN 2,60 MM	
	15	7675717	2	PASTIGLIA VALVOLA 2,65 MM	PAD, VALVE ADJUSTING 2.65 MM	PASTILLE REGLAGE CULBETEUR 2,65 MM	VENTILKAEPPOCHEN 2,65 MM	REGISTRO BALANCIN 2,65 MM	
	16	7728383	2	BICCHIERINO VALVOLA	TAPPET, VALVE	COUPELLE RETOUR SOUPAPE	VENTILEINSTELLSTOESSEL	TAQUE' RETORNO VALVULA	

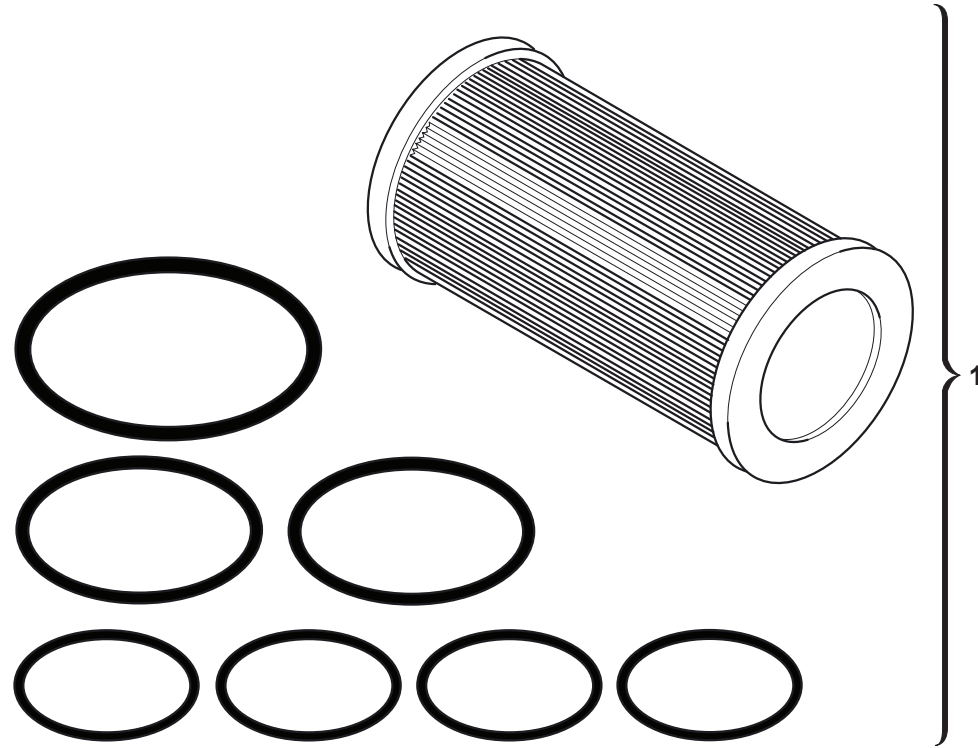



TAVOLA 2
DRAWING 2
TABLE 2
BILD 2
TABLA 2





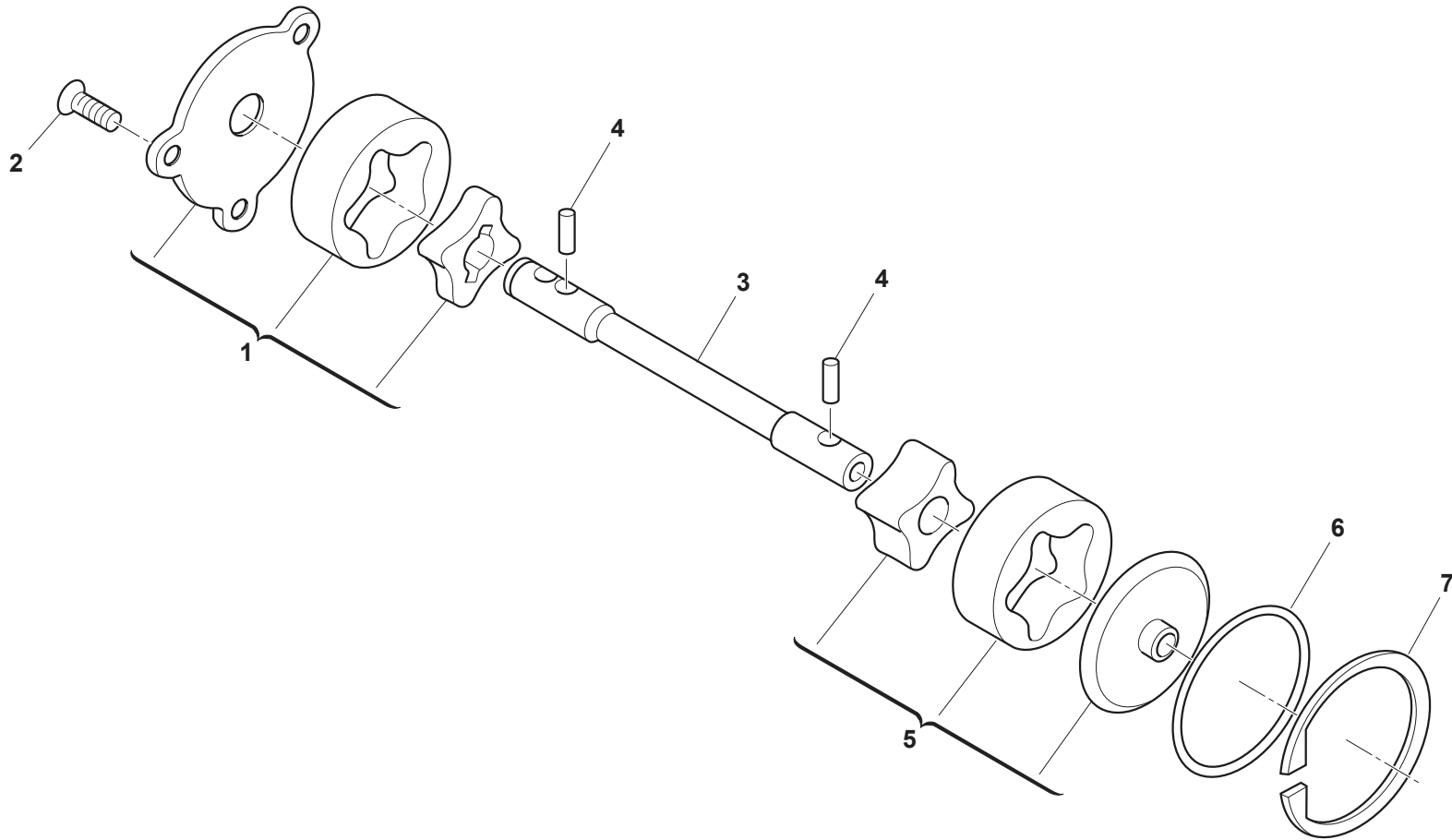
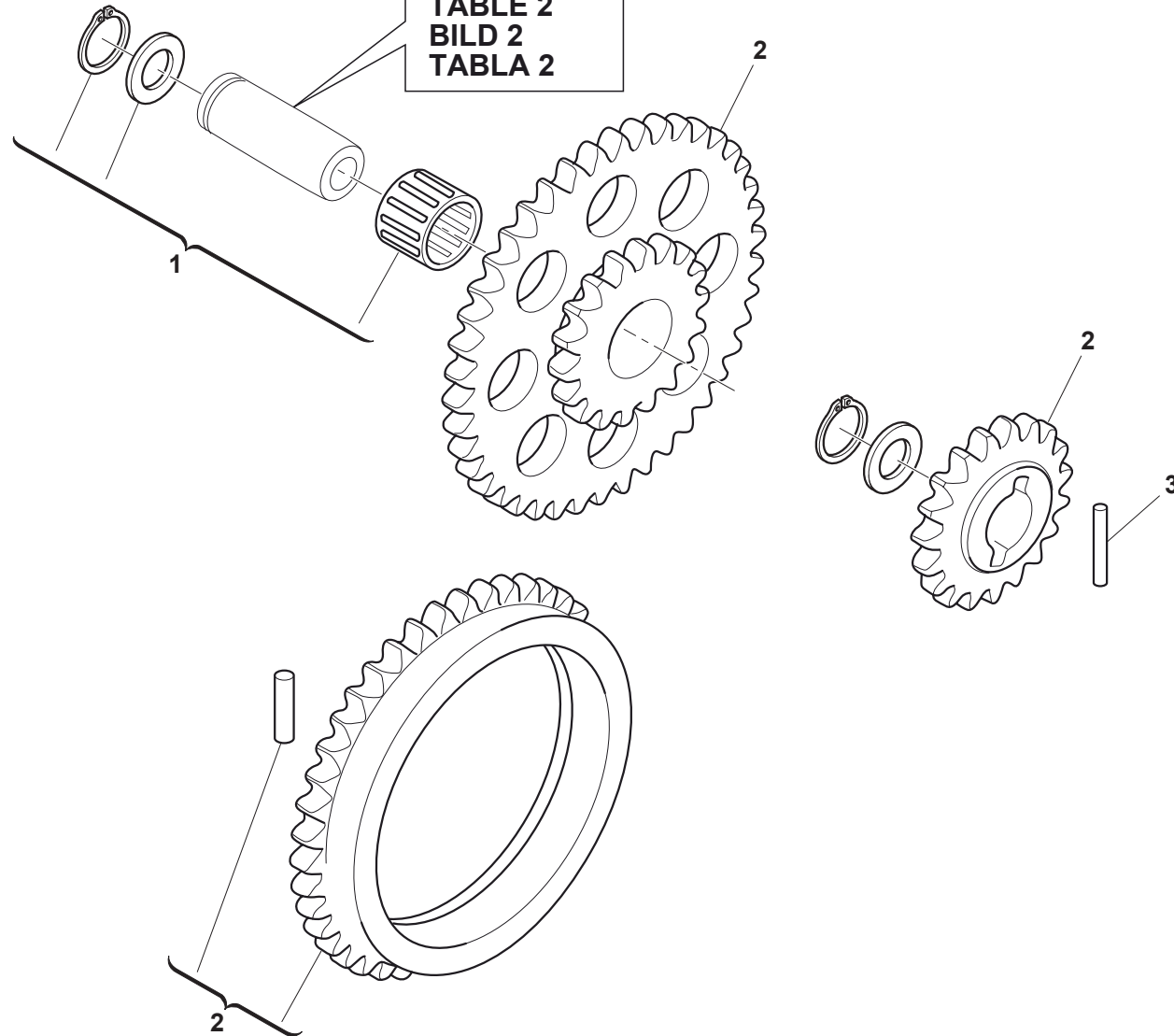
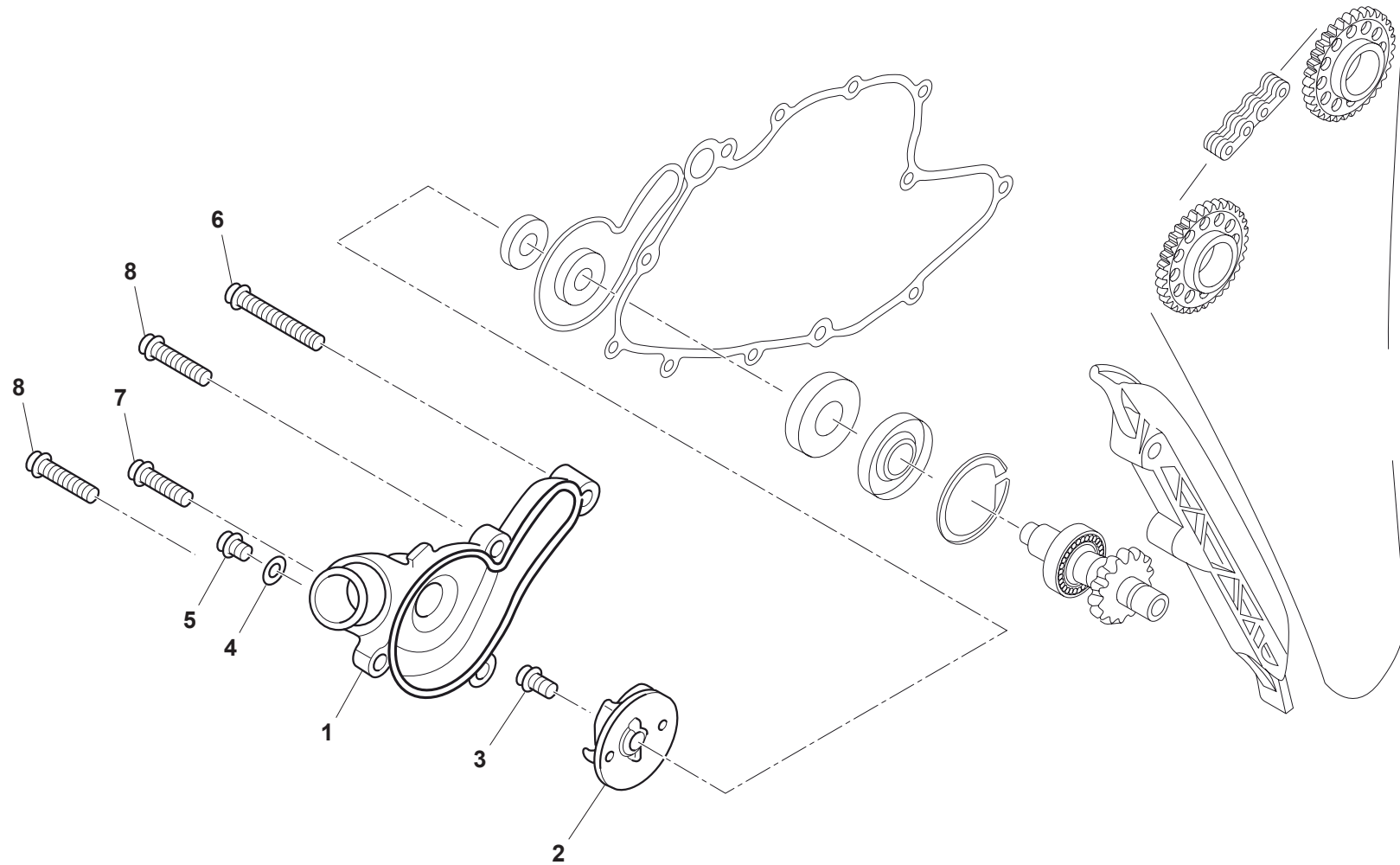

TAVOLA 4
DRAWING 4
TABLE 4
BILD 4
TABLA 4





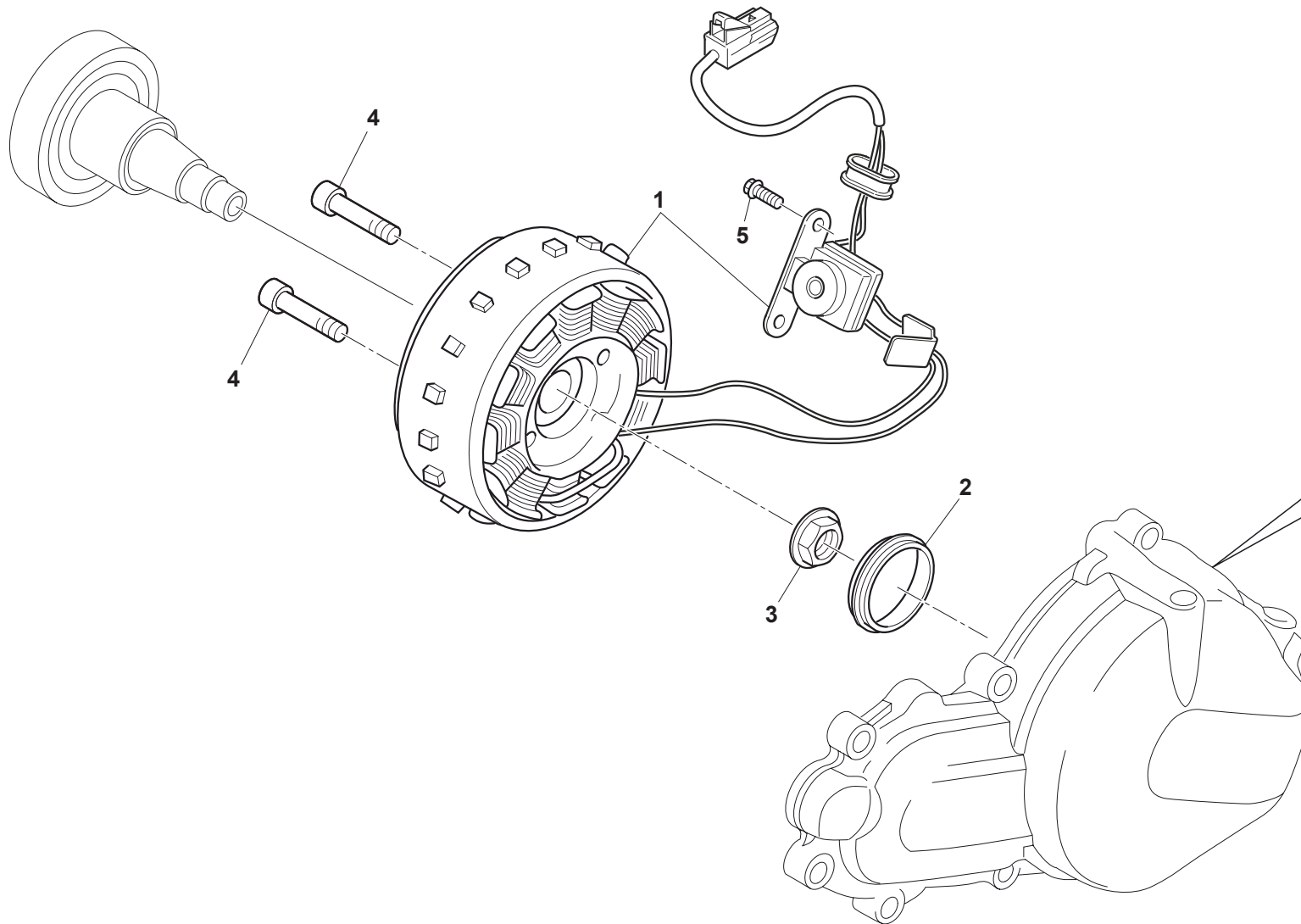
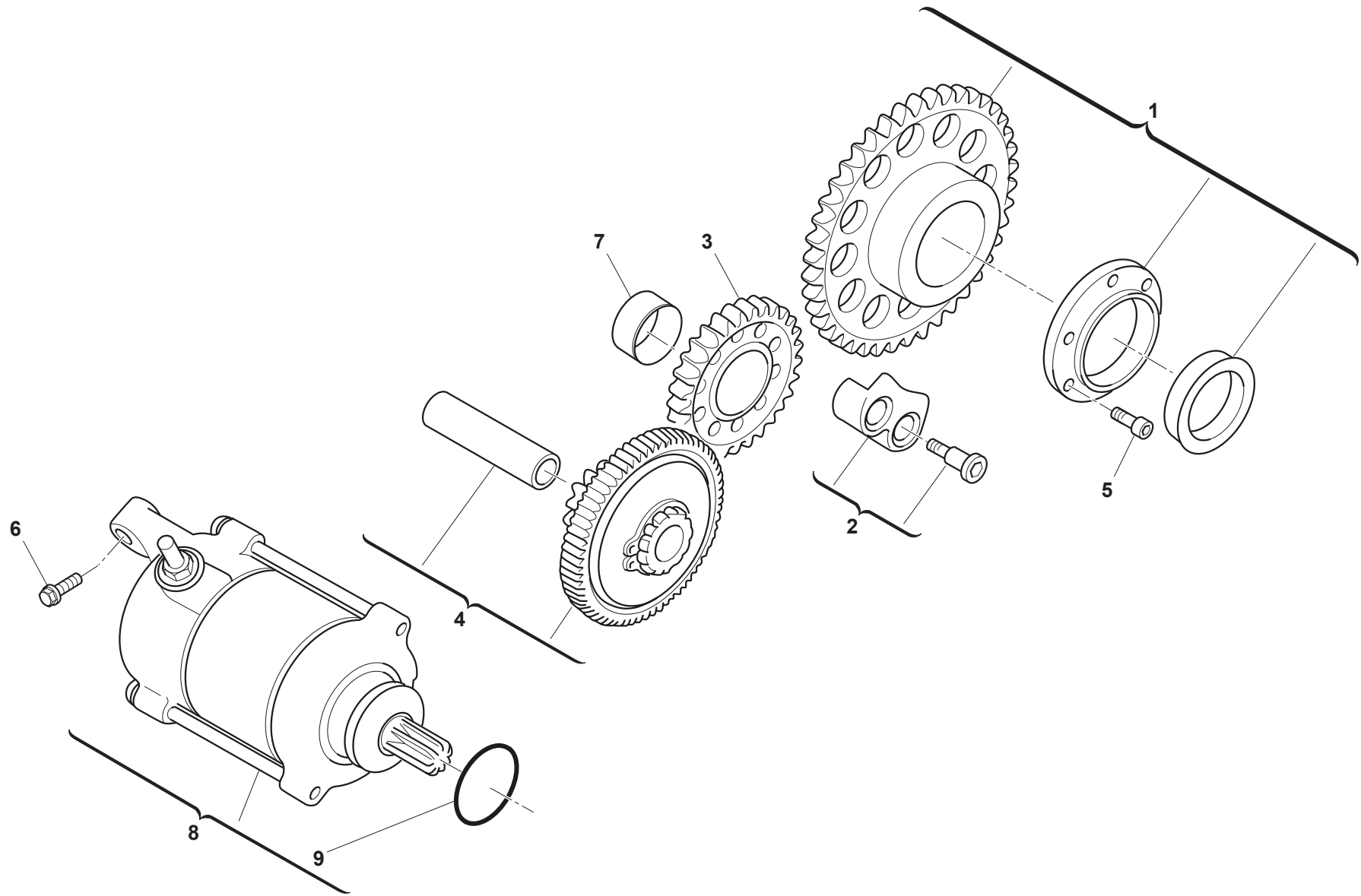
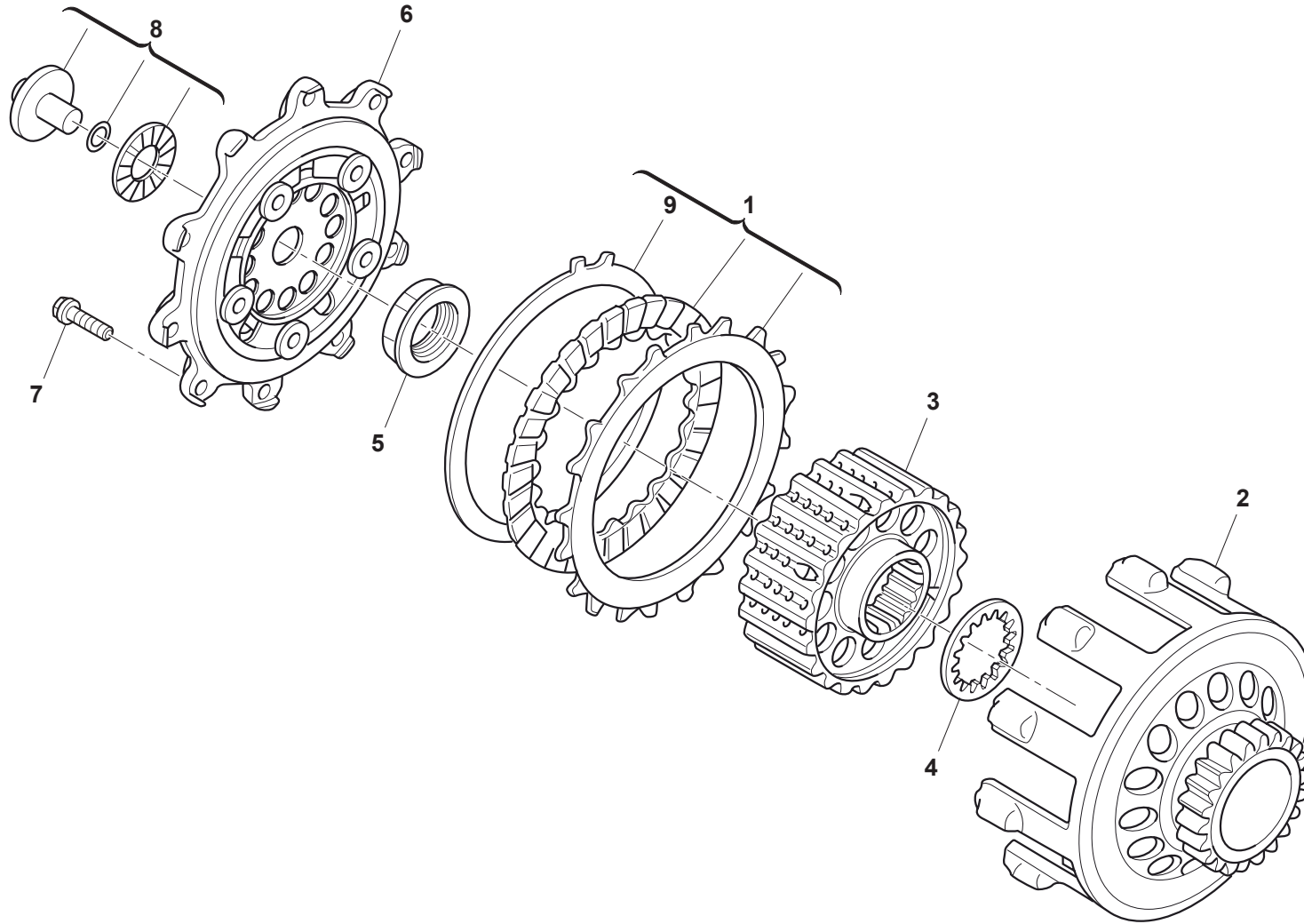
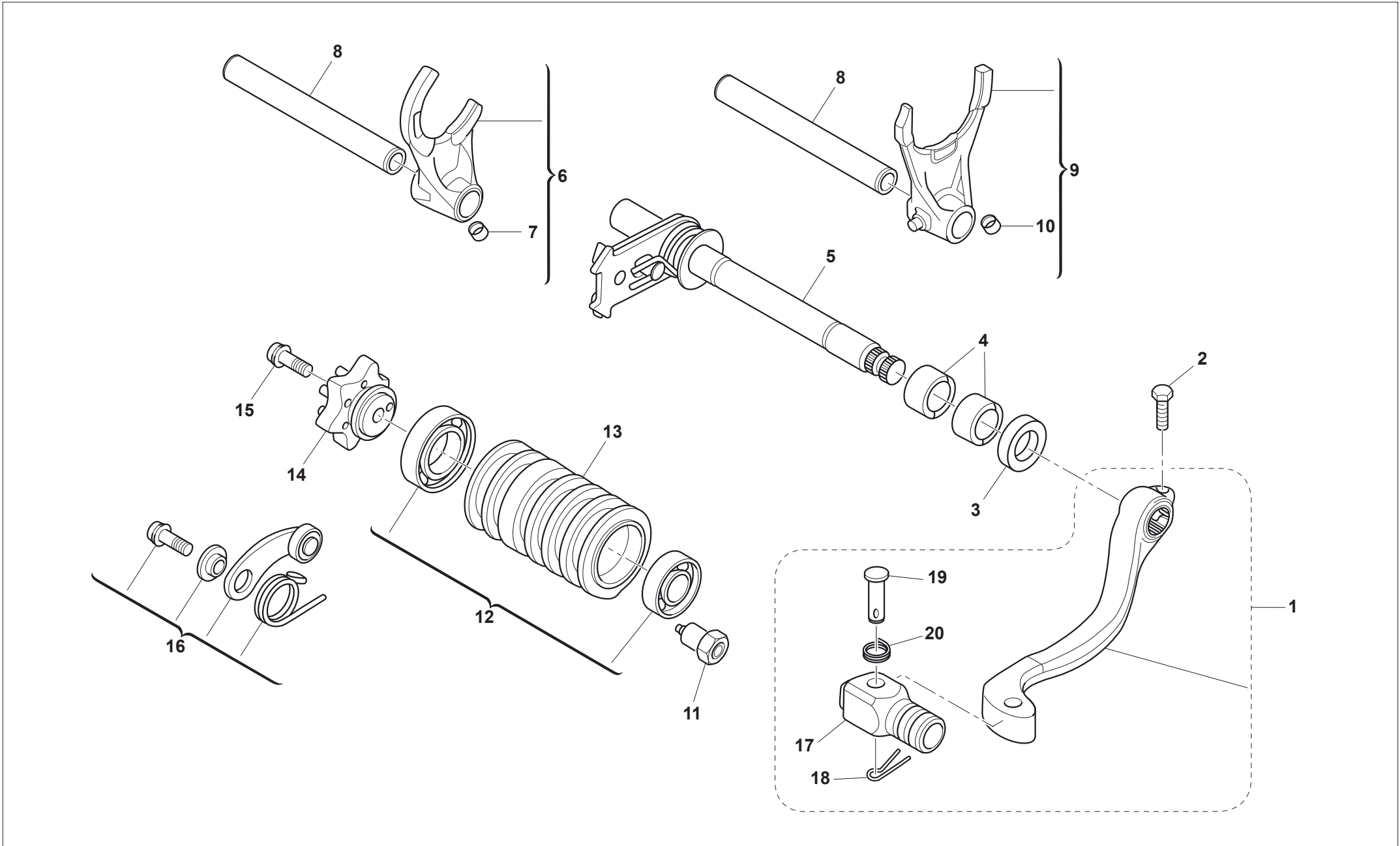

COMANDO CAMBIO - GEARSHIFT MECHANISM
COMMANDE DE VITESSE - GANGSCHALTUNG
MANDO CAMBIO
TAVOLA - DRAWING
TABLE - BILD - TABLA

22

Note Notes Marke Notas	Pos. No. Index Pos.	N. Cod. Code No. Nr. Code Code Nr N. Cod.	Q.tà Q.ty Q.te M.ge C.ad	DENOMINAZIONE	NAME	DESIGNATION	BESHREIBUNG	DENOMINACION	Validità Validity Validité Gültig Validez
	1	8000H2302	1	PEDALE CAMBIO	PEDAL, GEAR CHANGE	PEDALE CHANGEMENT VITESSE	SCHALTPEDAL	PEDAL, CAMBIO VELOCIDADES	
	2	8528881	1	VITE TCEI M6X20 CL.10.9	SCREW TCEI M6X20 CL.10.9	VIS TCEI M6X20 CL.10,9	SCHRAUBE TCEI M6X20 CL.10,9	TORNILLO TCEI M6X20 CL.10,9	
	3	7707478	1	PARAOLIO 14X24X6	SEAL, OIL 14X24X6	BAGUE D'ETANCHEITE 14X24X6	WELLENDICHTRING 14X24X6	RETEN ACEITE 14X24X6	
	4	9906600	2	CUSCINETTO A RULLI	BEARING, NEEDLE	ROULEMENT A ROULEAUX	ROLLENLAGER	COJINETE DE RODILLOS	
	5	7729352	1	ALBERO SELETTORE CAMBIO	GEAR SELECTOR SHAFT	ARBRE SELECTEUR DE VITESSES	SCHALTWELLE	ARBOL SELECTOR CAMBIO	
	6	7719434	1	FORCHETTA SELETTORE CAMBIO 4A-5A	SHIFT FORK 4TH-5TH	FOURCHE ENGRENEMENT 4EME-5EME	SCHALTGABEL 4,-5,	HORQUILLA SELECTOR 4A-5A	
	7	7707052	1	BOCCOLA	BUSH	DOUILLE	BUCHSE	BUJE	
	8	7707045	2	PERNO	PIN	PIVOT	BOLZEN	PERNO	
	9	7719437	2	FORCHETTA SELETTORE CAMBIO 2A-3A	FORK, GEAR SHIFTING 2ND-3RD	FOURCHE ENGRENEMENT 2EME-3EME	SCHALTGABEL 2,-3,	HORQUILLA SELECTOR 2NDA-3ERA	
	10	7707052	2	BOCCOLA	BUSH	DOUILLE	BUCHSE	BUJE	
	11	7726739	1	INTERRUTTORE FOLLE	SWITCH, NEUTRAL	INTERRUPTEUR TEMOIN POINT MORT	SCHALTER LEERLAUFLEUCHTE	INTERRUPTOR PUNTO MUERTO	
	12	7715465	1	GRUPPO CUSCINETTI	BEARING SET	GROUPE ROULEMENT	LAGERGRUPPE	GRUPO COJINETE	
	13	7707210	1	TAMBURO DESMODROMICO	CAM, GEAR SHIFT	TAMBOUR DESMODROMIQUE	VERSCHIEBENOCKEN	TAMBOR CAMBIO	
	14	7719669	1	ROCCHETTO DESMODROMICO	CAM-CHANGE DRUM	PIGNION DESMODROMIQUE	VERSCHIEBENOCKENRITZEL	PINION TAMBOR CAMBIO	
	15	7714603	1	VITE FLANGIATA	BOLT FLANGE	VIS A EMBASE	GEFLANSCHSCHRAUBE	TORNILLO CON VALONA	
	16	7700409	1	SALTARELLO FISSAMARCE	STOPPER, SHIFT CAM	CLIQUET	SPERRKLINKE	TRINQUETE FIJO MARCHAS	
	17	7712692	1	PEDALINO	PEDAL	PEDALE	PEDAL	PEDAL	
	18	9905447	1	COPIGLIA	PIN, COTTER	GOUPILLE, FENDUE	SPLINT	GRUPILLA	
	19	7716120	1	PERNO	PIN	PIVOT	BOLZEN	PERNO	
	20	7701614	1	MOLLA	SPRING	RESSORT	FEDER	MUELLE	

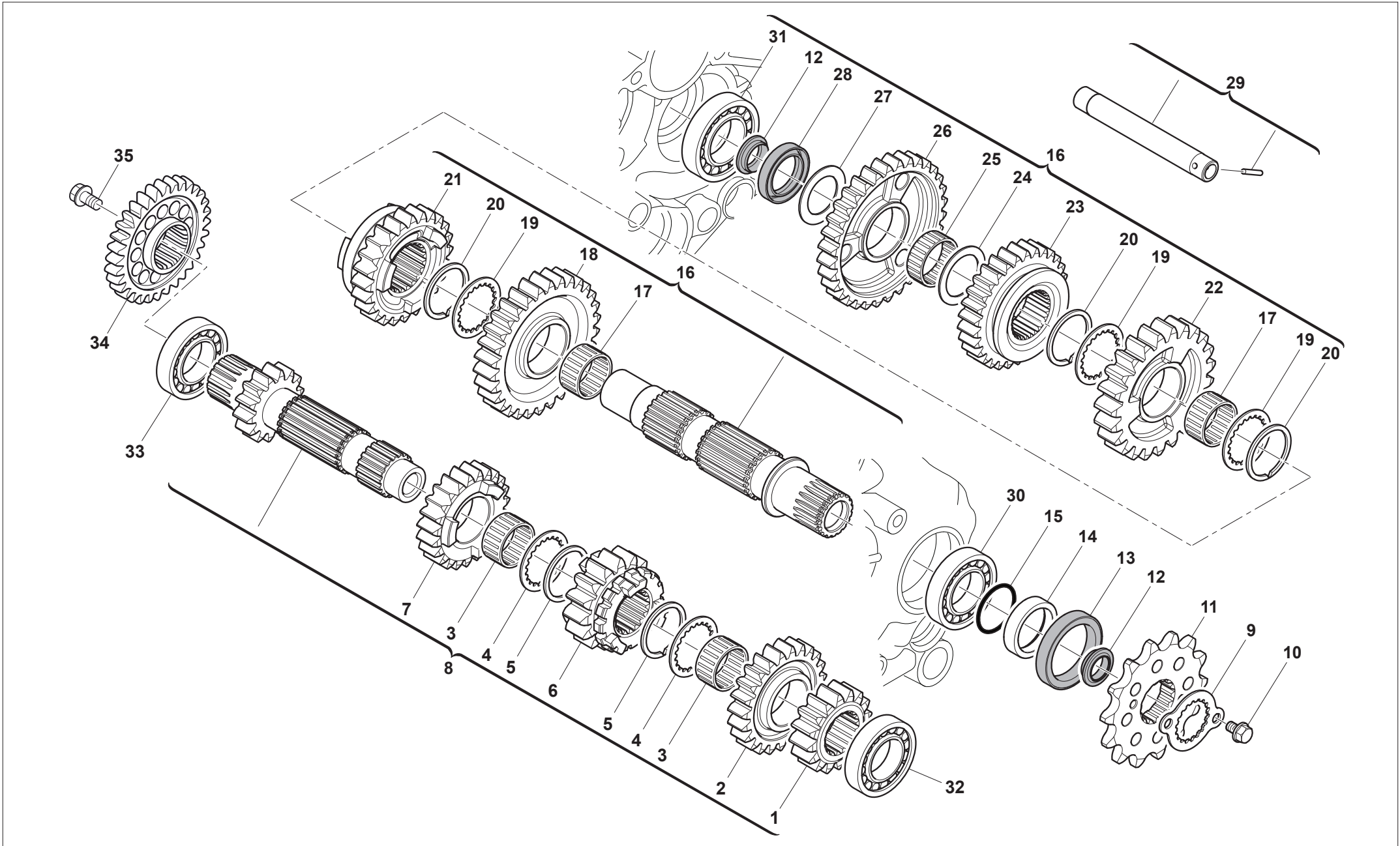

TRASMISSIONE PRIMARIA - PRIMARY DRIVE
TRANSMISSION PRIMAIRE - PRIMÄRÜBERSETZUNG
TRANSMISION PRIMARIA

TAVOLA - DRAWING
TABLE - BILD - TABLA

23

Note Notes Marke Notas	Pos. No. Index Pos.	N. Cod. Code No. Nr. Code Code Nr N. Cod.	Q.tà Q.ty M.ge C.ad	DENOMINAZIONE	NAME	DESIGNATION	BESHREIBUNG	DENOMINACION	Validità Validity Validité Gültig Validez
	1	7729340	1	INGRANAGGIO CONDUTTORE 2A Z16	GEAR INPUT 2ND 16T	ENGRENAGE MENANT 2EME VITESSE D16	TREIBENDES ZAHNRAD 2, GESCHWIND. Z16	ENGRANAJE CONDUCTOR 2NDA VELOCIDAD D16	
	2	7729331	1	INGRANAGGIO CONDUTTORE 5A Z23	GEAR DRIVE 5TH SPEED T23	ENGRENAGE MENANT 5EME VITESSE D23	TREIBENDES ZAHNRAD 5, GESCHWIND. Z23	ENGRANAJE CONDUCTOR 5A VELOCIDAD D23	
	3	7717729	2	CUSCINETTO A RULLI	BEARING, NEEDLE	ROULEMENT A ROULEAUX	ROLLENLAGER	COJINETE DE RODILLOS	
	4	7707142	2	RONDELLA RASAMENTO	WASHER, THRUST	RONDELLE BUTEE	DISTANZSCHEIBE	ARANDELA SEPARACION	
	5	7719438	2	ANELLO ELASTICO	SPRING RING	ANNEAU ARRET	SPRENGRING	ANILLO RETENCION	
	6	7729346	1	INGRANAGGIO CONDUTTORE 3A Z15	GEAR DRIVE 3RD SPEED T15	ENGRENAGE MENANT 3EME VITESSE D15	TREIBENDES ZAHNRAD 3, GESCHWIND. Z15	ENGRANAJE CONDUCTOR 3ERA VELOCIDAD D15	
	7	7729333	1	INGRANAGGIO CONDUTTORE 4A Z23	GEAR, 4TH DRIVE NT:23	ENGRENAGE MENANT 4EME VITESSE D23	TREIBENDES ZAHNRAD 4, GESCHWINDIGK.Z23	ENGRANAJE CONDUCTOR 4A VELOCIDAD D23	
	8	8527731	1	ALBERO PRIMARIO Z14	AXLE MAIN 14T	ARBRE PRIMAIRE D14	HAUPTWELLE Z14	ARBOL PRIMARIO CAMBIO D14	
	9	7706942	1	PIASTRINA FISSAGGIO PIGNONE	PLATE, SPROCKET	PLAQUE FIXATION PIGNON COMMANDE	FIXIERPLATTE, ANTRIEBSKETTENRAD	PLACA, FIJACION PINON DENTA	
	10	7714712	2	VITE M5X8	SCREW M5X8	VIS M5X8	SCHRAUBE M5X8	TORNILLO M5X8	
	11	7714723	1	PIGNONE Z13	SPROCKET, CHAIN 13T	PIGNON CHAINE D13	KETTENRITZEL Z13	PINON CADENA D13	
	11	7714722	1	PIGNONE Z14	SPROCKET, CHAIN T14	PIGNON CHAINE Z14	KETTENRITZEL Z14	PINON CADENA Z14	
STD	11	7706939	1	PIGNONE Z15	SPROCKET, CHAIN T15	PIGNON CHAINE Z15	KETTENRITZEL Z15	PINON CADENA Z15	
	12	7706945	2	GUARNIZIONE	GASKET	JOINT	DICHTUNG	JUNTA	
	13	7707480	1	PARAOLIO	SEAL, OIL	BAGUE D'ETANCHEITE	WELLENDICHRING	RETEN ACEITE	
	14	7706958	1	DISTANZIALE	SPACER	ENTRETOISE	ABSTANDHALTER	DISTANCIADOR	
	15	9906608	1	ANELLO O-RING	O-RING	JOINT TORIQUE	O-RING	JUNTA TORICA	
	16	8527732	1	ALBERO SECONDARIO	COUNTER SHAFT	ARBRE SECONDAIRE	ANTRIEBSWELLE	ARBOL SECONDARIO	
	17	7717723	2	CUSCINETTO A RULLI	BEARING, NEEDLE	ROULEMENT A ROULEAUX	ROLLENLAGER	COJINETE DE RODILLOS	
	18	7729355	1	INGRANAGGIO CONDOTTO 2A Z30	DRIVEN GEAR 2ND SPEED T30	ENGRENAGE ENTRAINE 2EME VITESSE D30	ANGETRIEBENES ZAHNRAD 2, GESCHWIND.Z30	ENGRANAJE ACCIONADO 2NDA VELOCIDAD D30	
	19	7707461	3	RONDELLA RASAMENTO	WASHER, THRUST	RONDELLE BUTEE	DISTANZSCHEIBE	ARANDELA SEPARACION	
	20	7719440	3	ANELLO ELASTICO	SPRING RING	ANNEAU ARRET	SPRENGRING	ANILLO RETENCION	
	21	7729351	1	INGRANAGGIO CONDOTTO 5A Z24	DRIVEN GEAR 5TH SPEED 24T	ENGRENAGE ENTRAINE 5EME VITESSE D24	ANGETRIEBENES ZAHNRAD 5, GESCHWIND. Z24,	ENGRANAJE ACCIONADO 5A VELOCIDAD D24	
	22	7729364	1	INGRANAGGIO CONDOTTO 3A Z23	DRIVEN GEAR 3RD SPEED T23	ENGRENAGE ENTRAINE 3EME VITESSE D23	ANGETRIEBENES ZAHNRAD 3, GESCHWIND. Z23	ENGRANAJE ACCIONADO 3ERA VELOCIDAD D23	
	23	7729363	1	INGRANAGGIO CONDOTTO 4A Z29	DRIVEN GEAR 4TH SPEED 29T	ENGRENAGE ENTRAINE 4EME VITESSE D29	ANGETRIEBENES ZAHNRAD 4, GESCHWIND. Z29	ENGRANAJE ACCIONADO 4A VELOCIDAD D29	
	24	7707472	1	RONDELLA	WASHER	RONDELLE	SCHEIBE	ARANDELA	
	25	8520641	1	CUSCINETTO A RULLI KD24X28X1	BEARING, NEEDLE KD24X28X1	ROULEMENT A ROULEAUX KD24X28X1	ROLLENLAGER KD24X28X1	COJINETE DE RODILLOS KD24X28X1	
	26	7729349	1	INGRANAGGIO CONDOTTO 1A Z32	DRIVEN GEAR 1ST SPEED T32	ENGRENAGE ENTRAINE 1ERE VITESSE D32	ANGETRIEBENES ZAHNRAD 1, GESCHWINDIG.Z32	ENGRANAJE ACCIONADO 1ERA VELOCIDAD D32	
	27	7707463	1	RONDELLA	WASHER	RONDELLE	SCHEIBE	ARANDELA	
	28	7707479	1	PARAOLIO	SEAL, OIL	BAGUE D'ETANCHEITE	WELLENDICHRING	RETEN ACEITE	
	29	7707182	1	TUBO LUBRIFICAZIONE CAMBIO	PIPE, GEAR LUBRICATION	TUYAU GRASSAGE BOITE VITESSES	SCHMIERLEITUNG, GETRIEBE	TUBO LUBRICACION CAMBIO	
	30	9900365	1	CUSCINETTO	BEARING	ROULEMENT	LAGER	COJINETE	
	31	9906630	1	CUSCINETTO	BEARING	ROULEMENT	LAGER	COJINETE	

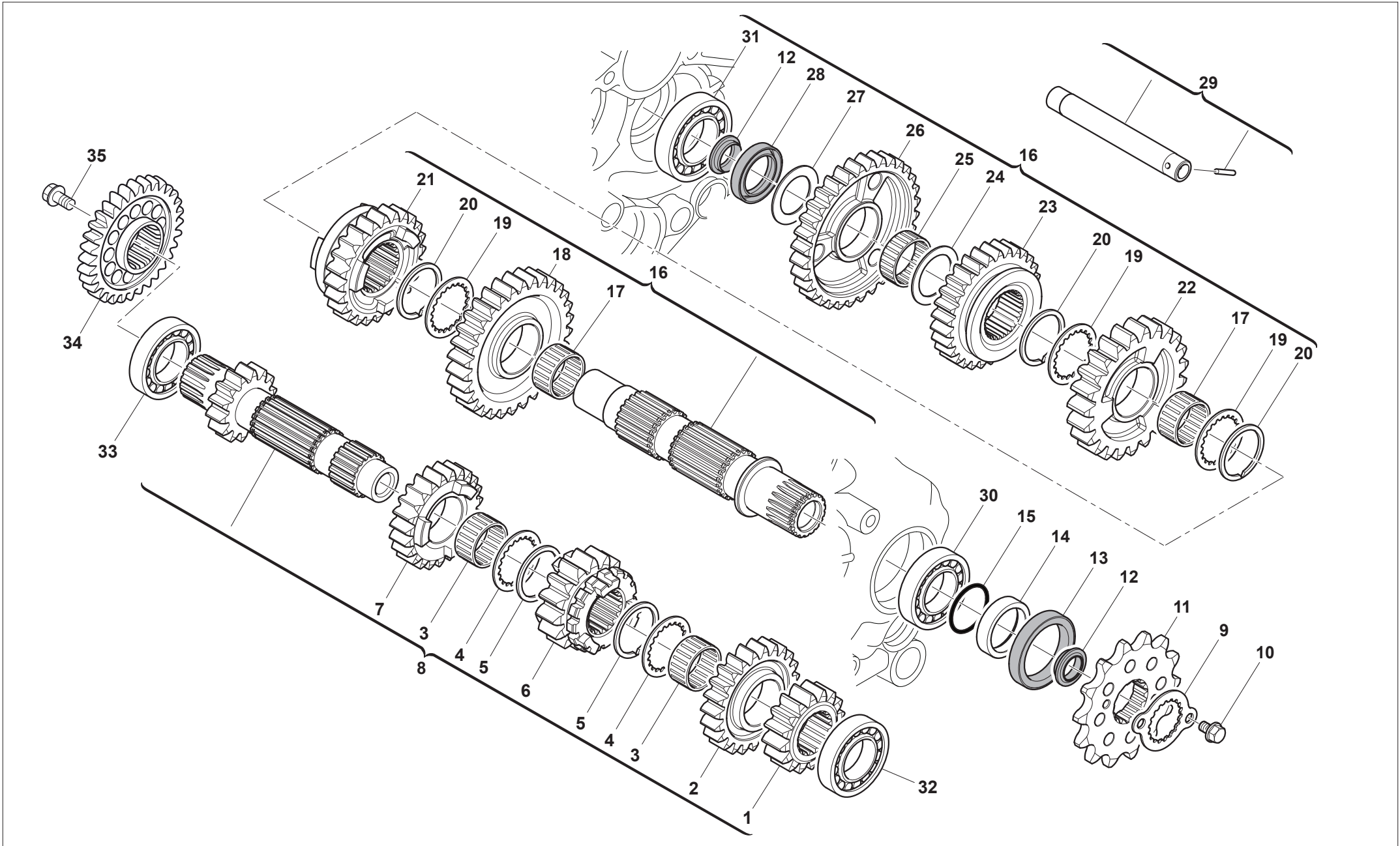



TAVOLA 24A
DRAWING 24A
TABLE 24A
BILD 24A
TABLA 24A

FILTRO ARIA - AIR FILTER
FILTRE AIRE - LUFTFILTER
FILTRO DE AIRE
TAVOLA - DRAWING
TABLE - BILD - TABLA

24

Note Notes Marke Notas	Pos. No. N. Index Pos.	N. Cod. Code No. Nr. Code Code Nr N. Cod.	Q.tà Q.ty Q.te M.ge C.ad	DENOMINAZIONE	NAME	DESIGNATION	BESHREIBUNG	DENOMINACION	Validità Validity Validité Gültig Validez
	1	8000H3097	1	CASSETTA FILTRO ARIA	CASE, AIR CLEANER	BOITE FILTRE A AIR	LUFTFILTERGEHAUSE	CAJA FILTRO AIRE	
	2	Z00062727	3	VITE TE M6X1X16 CH8	SCREW TE M6X1X16 CH8	VIS TE M6X1X16 CH8	SCHRAUBE TE M6X1X16 CH8	TORNILLO TE M6X1X16 CH8	
	3	8000B2799	3	DISTANZIALE 8X6,2X8,5	SPACER 8X6.2X8.5	ENTRETOISE 8X6,2X8,5	ABSTANDHALTER 8X6,2X8,5	DISTANCIADOR 8X6,2X8,5	
	4	8000H3731	3	PASSACAVO	GUIDE, CABLE	PASSE-CABLE	KABELDURCHGANG	PASACABLES	
	5	8000H3152	2	GANCIO	HOOK	CROCHET	HAKEN	GANCHO	
	6	8000H3151	1	SUPPORTO FILTRO ARIA	STAY, AIR CLEANER	APPUI FILTRE A AIR	STUETZE, LUFTFILTEREINSATZ	SOPORTE FILTRO AIRE	
	7	8000H3150	1	FILTRO ARIA	FILTER, AIR	FILTRE A AIR	LUFTFILTER	FILTRO AIRE	
	8	8000H7800	1	COPERCHIO CASSETTA FILTRO ARIA	COVER, AIR FILTER CASE	COUVERCLE BOITE FILTRE AIR	DECKEL LUFTFILTERGEHAUSE	CUBIERTA CAJA FILTRO AIRE	
	9	8000H3995	1	TUBO BLOW-BY	HOSE, BLOW-BY	TUYAU BLOW-BY	SCHLAUCH, BLOW-BY	TUBO BLOW-BY	
	10	8000H3153	1	PRESA ARIA	AIR INTAKE	CANALISATION PRISE AIR	LUFTANSAUGUNGSLEITUNG	TOMA AIRE	
	11	8000H6679	1	MANICOTTO CASSETTA FILTRO	TUBE, AIR CLEANER JOINT	RACCORD BOITE FILTRE A AIR	VERBINDUNGS, LUFTFILTERGEHAUSE	MANGUERA, CAJA FILTRO AIRE	
	12	8000H4201	1	FASCETTA	CLAMP	COLLIER	KLAMMER	ABRAZADERA	
	13	8A0092249	2	FASCETTA CLIC R 96-175 MM	HOSE CLAMP R 96-175 MM	COLLIER CLIC R 96-175 MM	SCHLAUCHSCHELLE R 96-175 MM	ABRAZADERA CLIC R 96-175 MM	
	14	8000H3646	1	SENSORE TEMPERATURA ARIA	SENSOR, AIR TEMPERATURE	CAPTEUR TEMPERATURE AIR	LUFTTEMPERATURFUEHLER	SENSOR TEMPERATURA AIRE	
	15	ZA0084658	2	VITE AUTOFILETTANTE	SCREW, TAPPING	VIS TARAUD	GEWINDESCHRAUBE	TORNILLO AUTOROSCANTE	

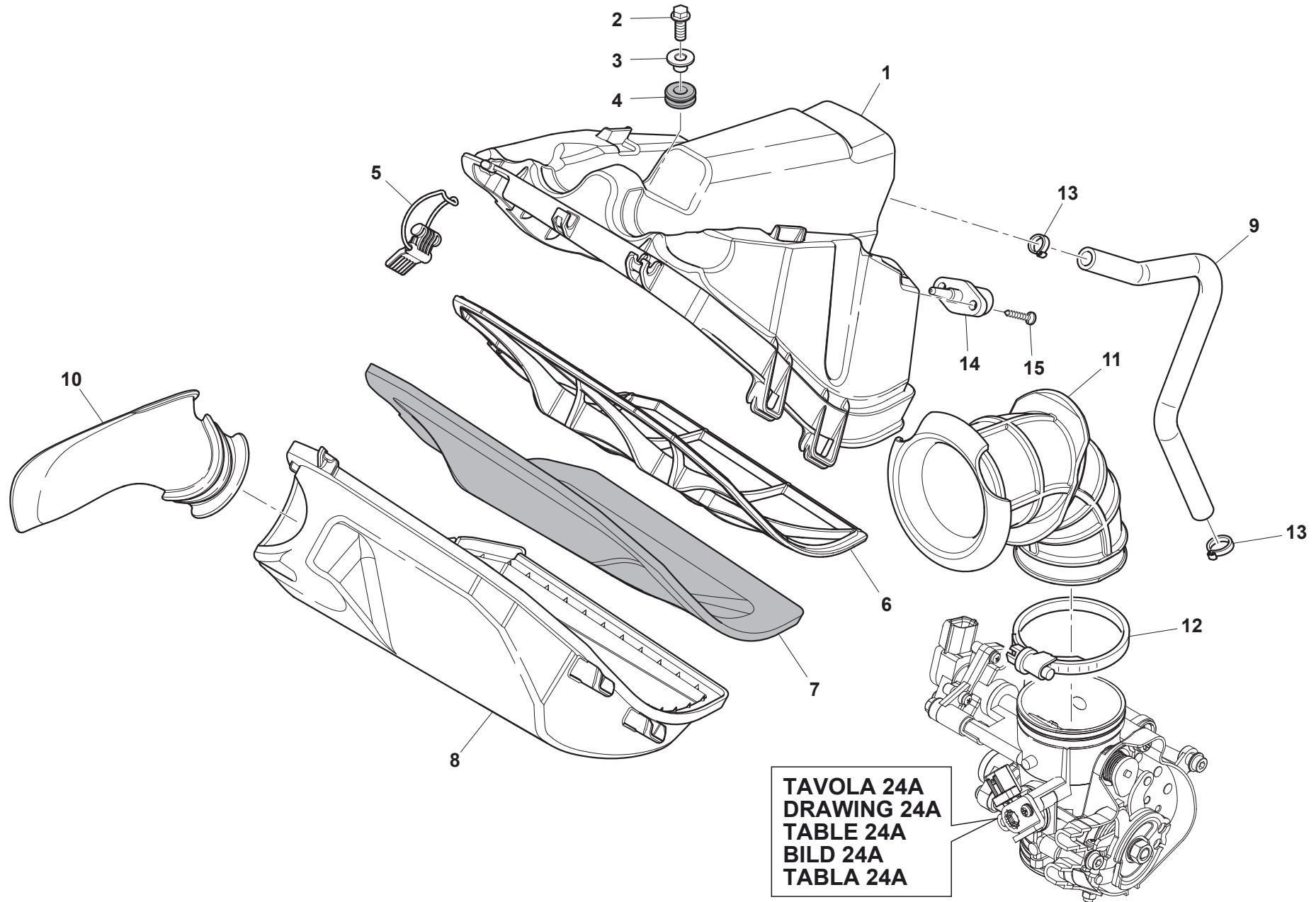
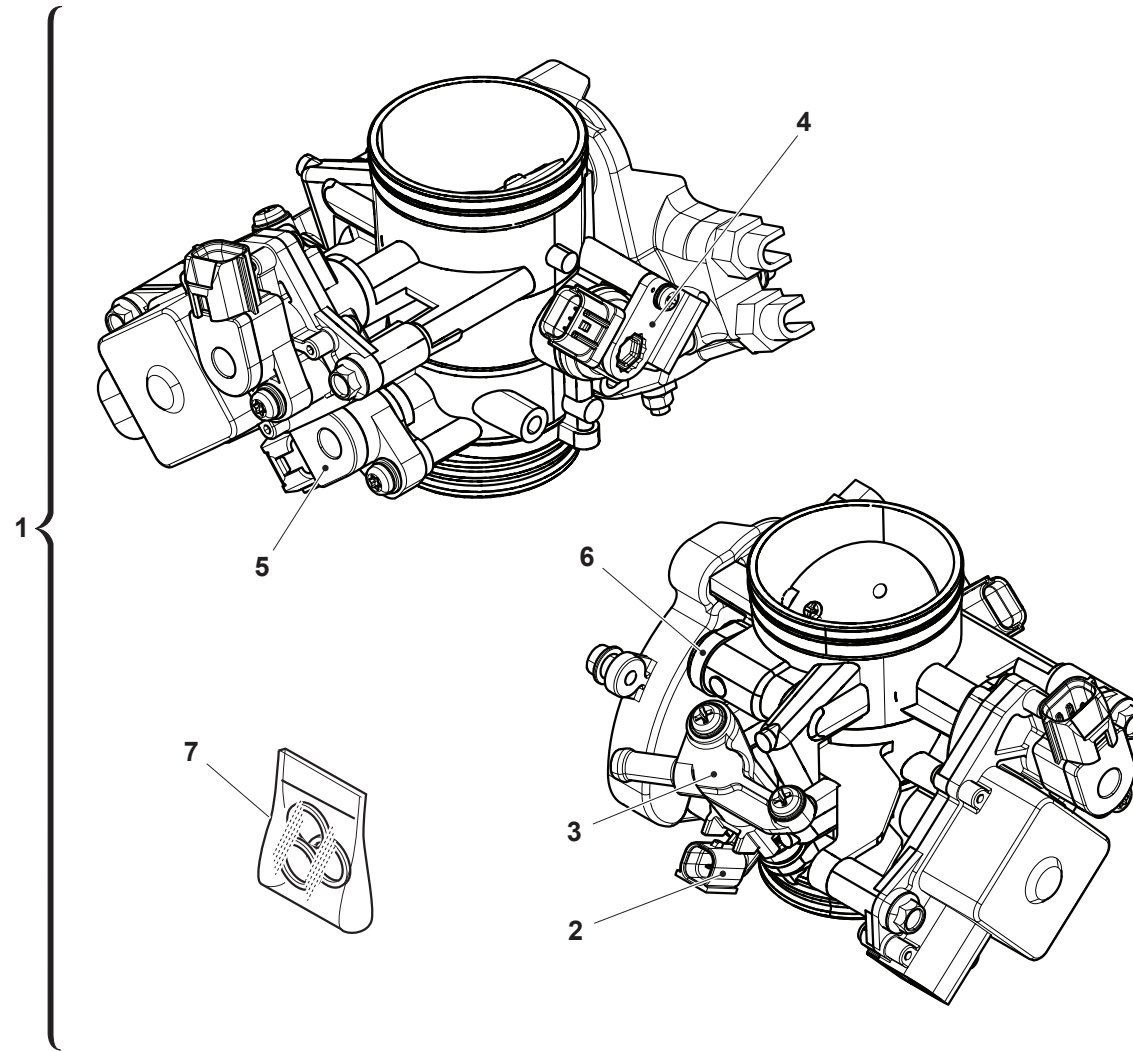

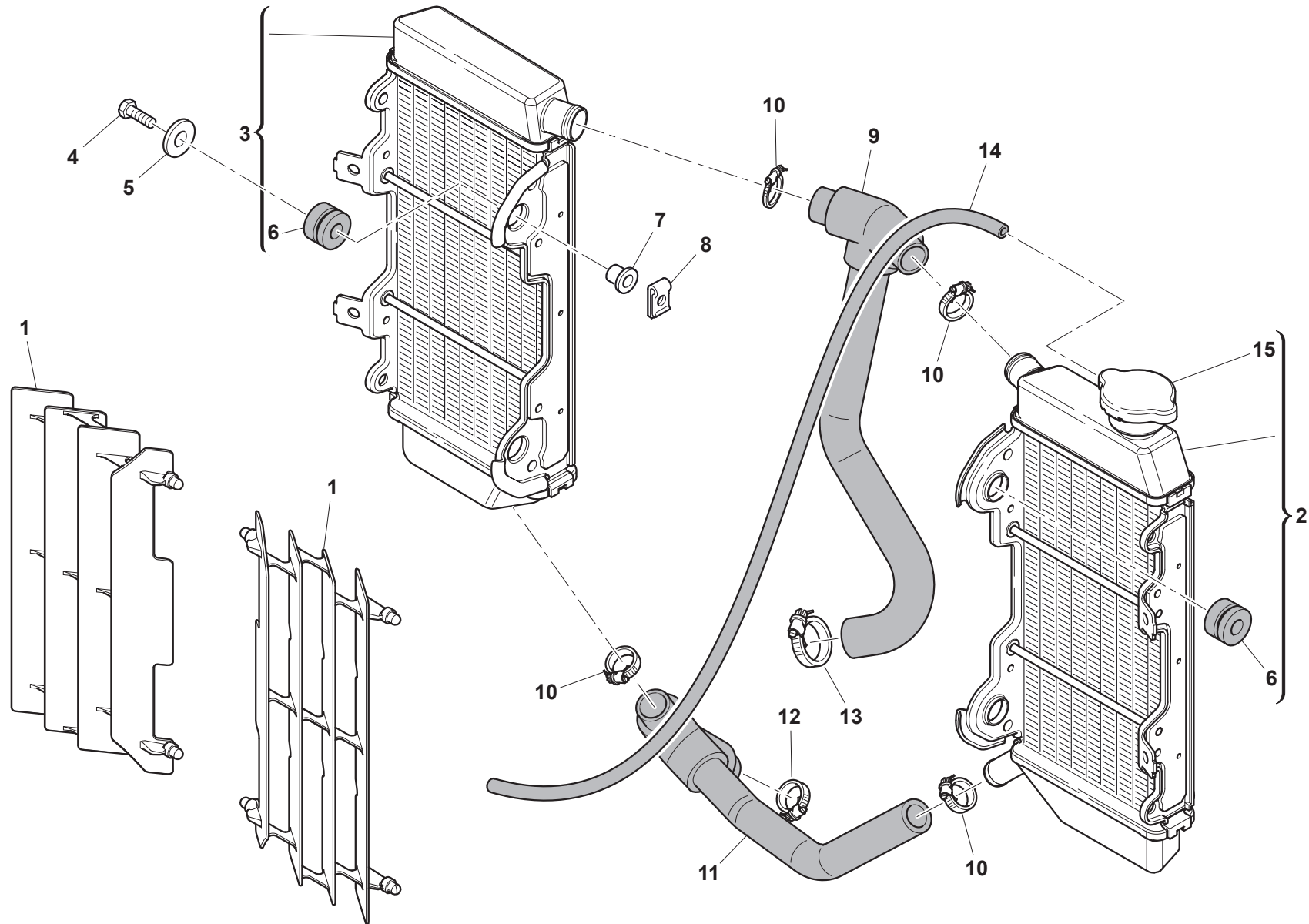

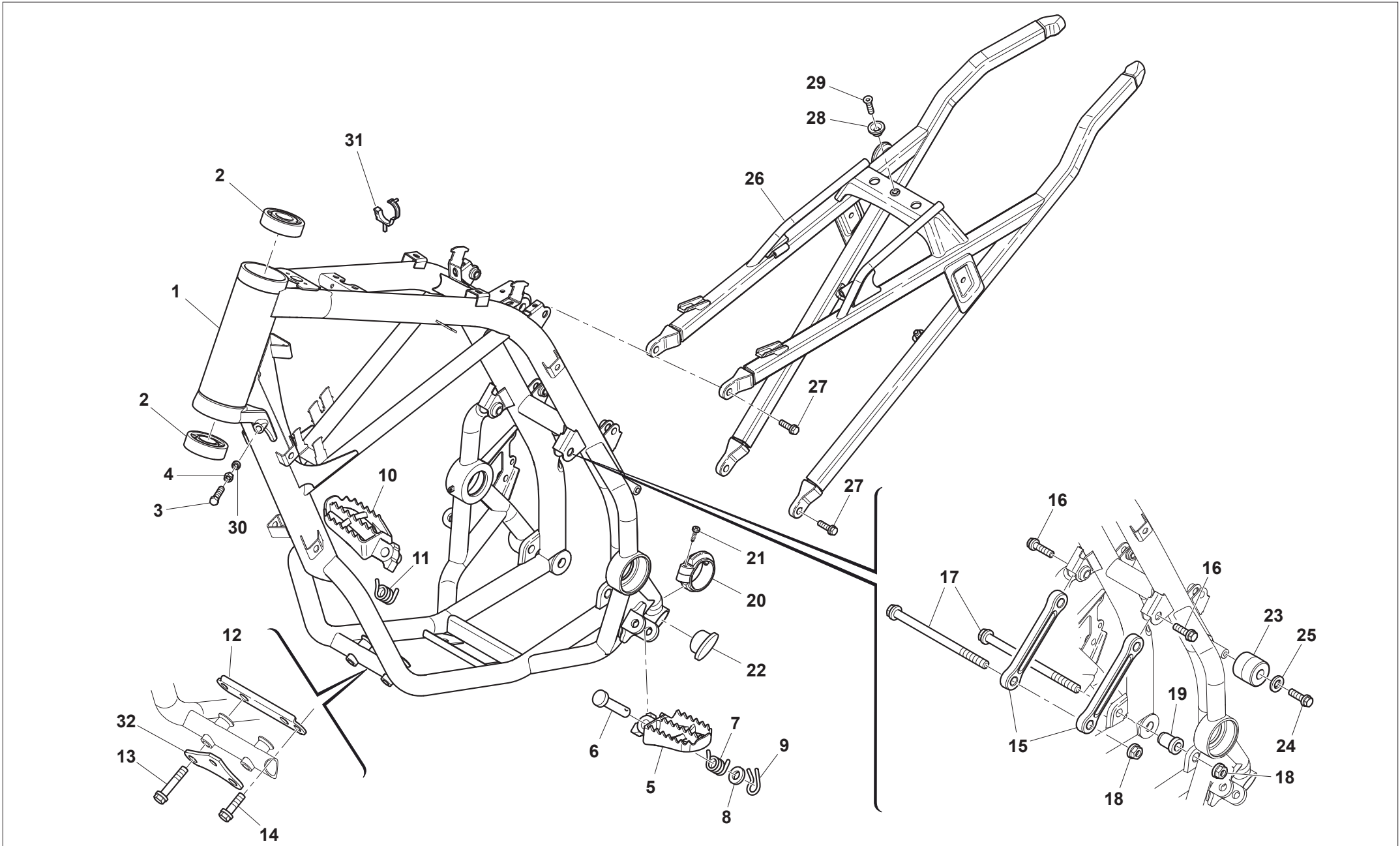

**TELAIO, PEDANE - FRAME, FOOT RESTS
CADRE, REPOSE PIEDS - RAHMEN, FUSSBRETT
BASTIDOR, REPOSAPIES**

TAVOLA - DRAWING
TABLE - BILD - TABLA

26

Note Notes Marke Notas	Pos. No. Index Pos.	N. Cod. Code No. Nr. Code Code Nr N. Cod.	Q.tà Q.ty M.ge C.ad	DENOMINAZIONE	NAME	DESIGNATION	BESHREIBUNG	DENOMINACION	Validità Validity Validité Gültig Validez
	1	8C00H2241	1	TELAIO	FRAME	CADRE	RAHMEN	BASTIDOR	
	2	800087243	2	CUSCINETTO A RULLI CONICI 29-48-17,5	CONICAL ROLLERS BEARING 29-48-17,5	ROULEMENT A ROULEAUX CONIQUES 29-48-17,5	KEGELROLLENLAGER 29-48-17,5	COJINETE DE RODILLOS CONICO 29-48-17,5	
	3	8B0092876	2	VITE TTEI M8X30	SCREW TTEI M8X30	VIS TTEI M8X30	SCHRAUBE TTEI M8X30	TORNILLO TTEI M8X30	
	4	Z00017810	2	DADO M8X1,25 H8 CH12	NUT M8X1.25 H8 CH12	ECROU M8X1,25 H8 CH12	MUTTER M8X1,25 H8 CH12	TUERCA M8X1,25 H8 CH12	
	5	80A089962	1	PEDANA ANTERIORE SINISTRA	FOOTREST, FRONT LH	REPOSE-PIEDS AVANT GAUCHE	VERDER FUSSRASTE LINKS	ESTRIBO DELANTERO IZQUERDO	
	6	Y00073140	2	PERNO PEDANA	PIN, FOOTREST	PIVOT REPOSE-PIEDS	BOLZEN, FUSSREST	PERNO ESTRIBO	
	7	800096907	1	MOLLA PEDANA SINISTRA	SPRING, FOOTREST LH	RESSORT REPOSE-PIEDS GAUCHE	FEDER, FUSSRASTE LINKS	MUELLE ESTRIBO IZQUERDO	
	8	ZA0001815	2	RONDELLA 16X10,5X1	WASHER 16X10,5X1	RONDELLE 16X10,5X1	SCHEIBE 16X10,5X1	ARANDELA 16X10,5X1	
	9	64ND20068	2	COPIGLIA 1,8X18	PIN, COTTER 1.8X18	GOUPILLE FENDUE 1,8X18	SPLINT 1,8X18	GRUPILLA 1,8X18	
	10	80A089953	1	PEDANA ANTERIORE DESTRA	FOOTREST, FRONT RH	REPOSE-PIEDS AVANT DROIT	VORNE FUSSRASTE, RECHTS	ESTRIBO DELANTERO DERECHO	
	11	800096908	1	MOLLA PEDANA DESTRA	SPRING, FOOTREST, RH	RESSORT REPOSE-PIEDS DROIT	FEDER, FUSSRASTE RECHTS	MUELLE ESTRIBO DERECHO	
	12	8000H2891	1	PIASTRINA SUPPORTO MOTORE	BRACKET, ENGINE MOUNT	SUPPORT MOTEUR	MOTORHALTERUNG	SOPORTE MOTOR	
	13	Z00062795	2	VITE TEF M8X1,25X50 CH12	SCREW TEF M8X1,25X50 CH12	VIS TEF M8X1,25X50 CH12	SCHRAUBE TEF M8X1,25X50 CH12	TORNILLO TEF M8X1,25X50 CH12	
	14	8000B1959	2	VITE TEF M8X1,25X25 CH10	SCREW TEF M8X1,25X25 CH10	VIS TEF M8X1,25X25 CH10	SCHRAUBE TEF M8X1,25X25 CH10	TORNILLO TEF M8X1,25X25 CH10	
	15	8000H2646	2	SUPPORTO MOTORE POSTERIORE	BRACKET, REAR MOUNTING	SUPPORT MOTEUR ARRIERE	MOTORKONSOLE, HINTEN	SOPORTE MOTOR TRASERO	
	16	ZF0062797	2	VITE TEF M10X1,25X30	SCREW TEF M10X1,25X30	VIS TEF M10X1,25X30	SCHRAUBE TEF M10X1,25X30	TORNILLO TEF M10X1,25X30	
	17	8000H3914	2	VITE TEF M10X1,25X153	SCREW TEF M10X1,25X153	VIS TEF M10X1,25X153	SCHRAUBE TEF M10X1,25X153	TORNILLO TEF M10X1,25X153	
	18	Z00042022	2	DADO M10X1,25 H10 CH14	NUT M10X1.25 H10 CH14	ECROU M10X1,25 H10 CH14	MUTTER M10X1,25 H10 CH14	TUERCA M10X1,25 H10 CH14	
	19	8A0069282	1	DISTANZIALE 14X7X5,25 MM	SPACER 14X7X5,25 MM	ENTRETOISE 14X7X5,25 MM	ABSTANDHALTER 14X7X5,25 MM	DISTANCIADOR 14X7X5,25 MM	
	20	8000H3093	1	PATTINO CATENA	CHAIN SHOE	DOIGT CHAINE	GLEITAUFLAGE	PATIN CADENA	
	21	8000H4036	1	VITE AUTOFILETTANTE 6X25 CH8	SCREW SELF-TAPPING 6X25 CH8	VIS TARAUD 6X25 CH8	GEWINDESCHRAUBE 6X25 CH8	TORNILLO AUTOROSCANTE 6X25 CH8	
	22	8000H2982	2	TAPPO 27 MM	PLUG 27 MM	BOUCHON 27 MM	VERSCHLUSS 27 MM	TAPON 27 MM	
	23	800056800	1	RULLO TENDICATENA	ROLLER, CHAIN TENSIONER	ROULEAU, TENDEUR CHAINE	ROLLE, KETTENSANNER	RODILLO, TENSIONADOR CADENA	
	24	8B00A8423	1	VITE FLANGIATA M6X16	BOLT FLANGE M6X16	VIS A EMBASE M6X16	GEFLANSCHSCHRAUBE M6X16	TORNILLO CON VALONA M6X16	
	25	Z00030319	1	RONDELLA 20X6,4X2,5	WASHER 20X6,4X2,5	RONDELLE 20X6,4X2,5	SCHEIBE 20X6,4X2,5	ARANDELA 20X6,4X2,5	
	26	8A00H2243	1	TELAIO POSTERIORE	REAR FRAME	CADRE ARRIERE	HINTERER RAHMEN	BASTIDOR TRASERO	
	27	Z00069056	4	VITE TEF M8X1,25X20 CH12	SCREW TEF M8X1,25X20 CH12	VIS TEF M8X1,25X20 CH12	SCHRAUBE TEF M8X1,25X20 CH12	TORNILLO TEF M8X1,25X20 CH12	
	28	8A0066238	1	DISTANZIALE	SPACER	ENTRETOISE	ABSTANDHALTER	DISTANCIADOR	
	29	60ND04134	1	VITE TSCI M6X1X20	SCREW TSCI M6X1X20	VIS TSCI M6X1X20	SCHRAUBE TSCI M6X1X20	TORNILLO TSCI M6X1X20	
	30	Z00008536	2	RONDELLA 13X8,4X2	WASHER 13X8,4X2	RONDELLE 13X8,4X2	SCHEIBE 13X8,4X2	ARANDELA 13X8,4X2	
	31	800058207	1	FASCETTA FERMACAVO 15 MM	GUIDE, CABLE 15 MM	PASSE-CABLE 15 MM	KABELDURCHGANG 15 MM	PASACABLES 15 MM	
	32	8000H4197	1	PIASTRA	PLATE	PLAQUE	PLATTE	PLACA	

TAVOLA 27A
DRAWING 27A
TABLE 27A
BILD 27A
TABLA 27A

22



TAVOLA 27A
DRAWING 27A
TABLE 27A
BILD 27A
TABLA 27A



SOSPENSIONE ANTERIORE 1/2 - FRONT FORK ASSEMBLY 1/2
SUSPENSION AVANT 1/2 - VORDERTELESKOPGABEL 1/2
SUSPENSION DELANTERA 1/2

TAVOLA - DRAWING
TABLE - BILD - TABLA

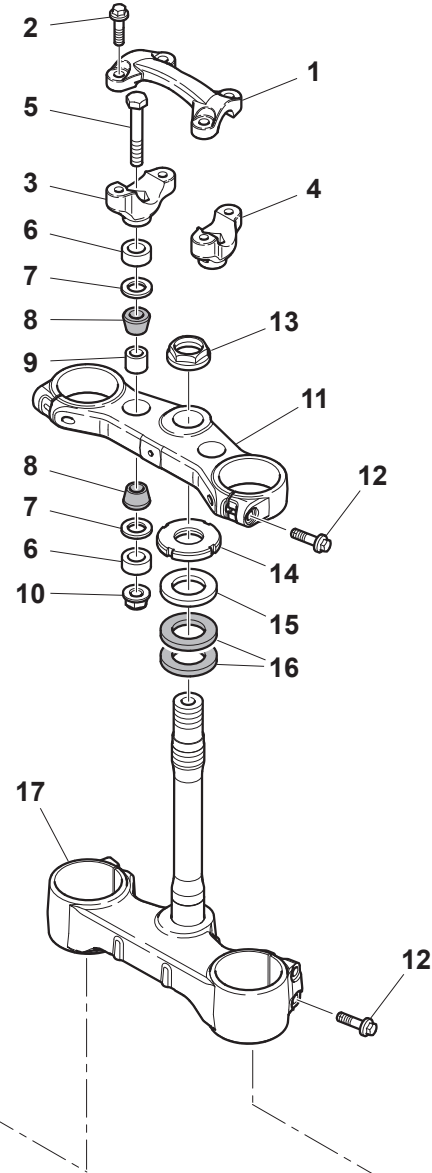
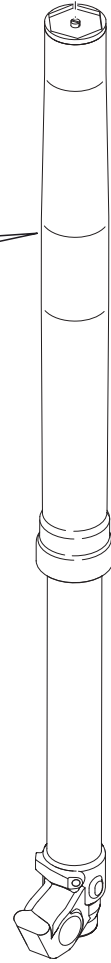
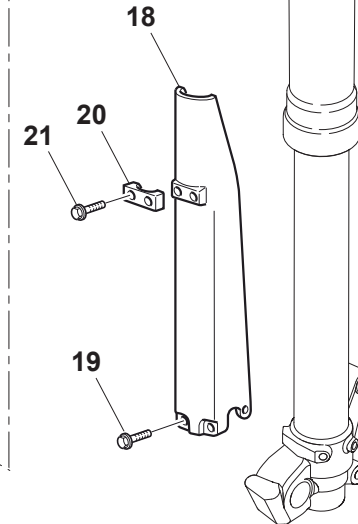
27

Note Notes Marke Notas	Pos. No. Index Pos.	N. Cod. Code No. Nr. Code Code Nr N. Cod.	Q.tà Q.ty Q.te M.ge C.ad	DENOMINAZIONE	NAME	DESIGNATION	BESHREIBUNG	DENOMINACION	Validità Validity Validité Gültig Validez
	1	8000H1358	1	CAVALLOTTO MANUBRIO SUPERIORE	HANDLEBAR BRACKET, UPPER	BRIDE GUIDON, SUPERIEURE	LENKER BUEGELBOLZEN, OBERE	PUENTE MANILLAR, SUPERIOR	
	2	8A00B1959	4	VITE TEF M8X1,25X30 CH10	SCREW TEF M8X1.25X30 CH10	VIS TEF M8X1,25X30 CH10	SCHRAUBE TEF M8X1,25X30 CH10	TORNILLO TEF M8X1,25X30 CH10	
	3	8000H1715	1	CAVALLOTTO MANUBRIO INFERIORE DESTRO	HANDLEBAR BRACKET, LOWER RH	BRIDE GUIDON, INFERIEUR DROIT	LENKER BUEGELBOLZEN, UNTEN RECHTS	PUENTE MANILLAR, INFERIOR DERECHO	
	4	8000H1357	1	CAVALLOTTO MANUBRIO INFERIORE SINISTRO	HANDLEBAR BRACKET, LOWER LH	BRIDE GUIDON, INFERIEUR GAUCHE	LENKER BUEGELBOLZEN, UNTEN LINKS	PUENTE MANILLAR, INFERIOR IZQUERDO	
	5	60ND01219	2	VITE TE M10X1,5X65	SCREW TE M10X1.5X65	VIS TE M10X1,5X65	SCHRAUBE TE M10X1,5X65	TORNILLO TE M10X1,5X65	
	6	8A00A6683	4	DISTANZIALE 32X10X13,5 MM	SPACER 32X10X13.5 MM	ENTRETOISE 32X10X13,5 MM	ABSTANDHALTER 32X10X13,5 MM	DISTANCIADOR 32X10X13,5 MM	
	7	800060234	4	RONDELLA 28X22X10,5X2,5 MM	WASHER 28X22X10.5X2.5 MM	RONDELLE 28X22X10,5X2,5 MM	SCHEIBE 28X22X10,5X2,5 MM	ARANDELA 28X22X10,5X2,5 MM	
	8	8000H1385	4	SILENTBLOCK	DAMPER	SILENTBLOC	SCHWINGUNGSDAEMPFER	CASQUILLO ELASTICO	
	9	8000H1714	2	DISTANZIALE 12X10 MM	SPACER 12X10 MM	ENTRETOISE 12X10 MM	ABSTANDHALTER 12X10 MM	DISTANCIADOR 12X10 MM	
	10	Z00061314	2	DADO AUTOBLOCCANTE M10X1,5	NUT, SELF LOCKING M10X1.5	ECROU AUTOBLOQUANT M10X1,5	SELBSTSPERRENDE MUTTE M10X1,5	TUERCA AUTOBLOQUEANTE M10X1,5	
	11	8000H1286	1	PIASTRA FORCELLA SUPERIORE	HEAD, STEERING STEM	TETE DIRECTION	GABELKOPF	TIJA SUPERIOR	
	12	8E00B1959	4	VITE TEF M8X1,25X40 CH12	SCREW TEF M8X1.25X40 CH12	VIS TEF M8X1,25X40 CH12	SCHRAUBE TEF M8X1,25X40 CH12	TORNILLO TEF M8X1,25X40 CH12	
	13	8A0069315	1	DADO CANNOTTO M26X1 CH30	NUT, STEERING STEM M26X1 CH30	ECROU FOURCHE M26X1 CH30	GABELMUTTER M26X1 CH30	TUERCA HORQUILLA M26X1 CH30	
	14	8A0087717	1	GHIERA CANNOTTO STERZO	BOLT STEERING HEAD TOP	ECROU SUPERIEUR TETE DIRECTION	OBER-GEWINDE, STEUERKOPF	TUERCA SUPERIOR CABEZAL DIRECCION	
	15	Z00087736	1	RONDELLA 40,5X29,5X2	WASHER 40.5X29.5X2	RONDELLE 40,5X29,5X2	SCHEIBE 40,5X29,5X2	ARANDELA PLANA 40,5X29,5X2	
	16	800087745	2	GUARNIZIONE	GASKET	JOINT	DICHTUNG	JUNTA	
	17	8000H1354	1	PIASTRA FORCELLA INFERIORE	STEM, STEERING	SOCLE DIRECTION	GABELBRUECKE, UNTEN	BASE DIRECCION	
	18	80A0A8481	1	PROTEZIONE STELO FORCELLA SINISTRO	GUARD FORK TUBE, LH	PROTECTION TIGE FOURCHE GAUCHE	GABELSTANGENSCHUTZ LINKS	PROTECCION VARILLA IZQUERDA	
	19	8000A8423	6	VITE FLANGIATA M6X8	BOLT, FLANGE M6X8	VIS A EMBASE M6X8	GEFLANSCHSCHRAUBE M6X8	TORNILLO CON VALONA M6X8	
	20	80A0A0633	1	FERMACAVO	CLAMP, WIRE	COLLIER, CORDON	KABELKLEMME	GRAMPA CORDON	
	21	ZA0084658	2	VITE AUTOFILETTANTE	SCREW, TAPPING	VIS TARAUD	GEWINDESCHRAUBE	TORNILLO AUTOROSCANTE	
	22	80A0A8482	1	PROTEZIONE STELO FORCELLA DESTRO	GUARD FORK TUBE, RH	PROTECTION TIGE FOURCHE DROITE	GABELSTANGENSCHUTZ RECHTS	PROTECCION VARILLA DERECHA	



TAVOLA 27
DRAWING 27
TABLE 27
BILD 27
TABLA 27

TAVOLA 27
DRAWING 27
TABLE 27
BILD 27
TABLA 27

SOSPENSIONE ANTERIORE 2/2 - FRONT FORK ASSEMBLY 2/2
SUSPENSION AVANT 2/2 - VORDERTELESKOPGABEL 2/2
SUSPENSION DELANTERA 2/2

TAVOLA - DRAWING
TABLE - BILD - TABLA

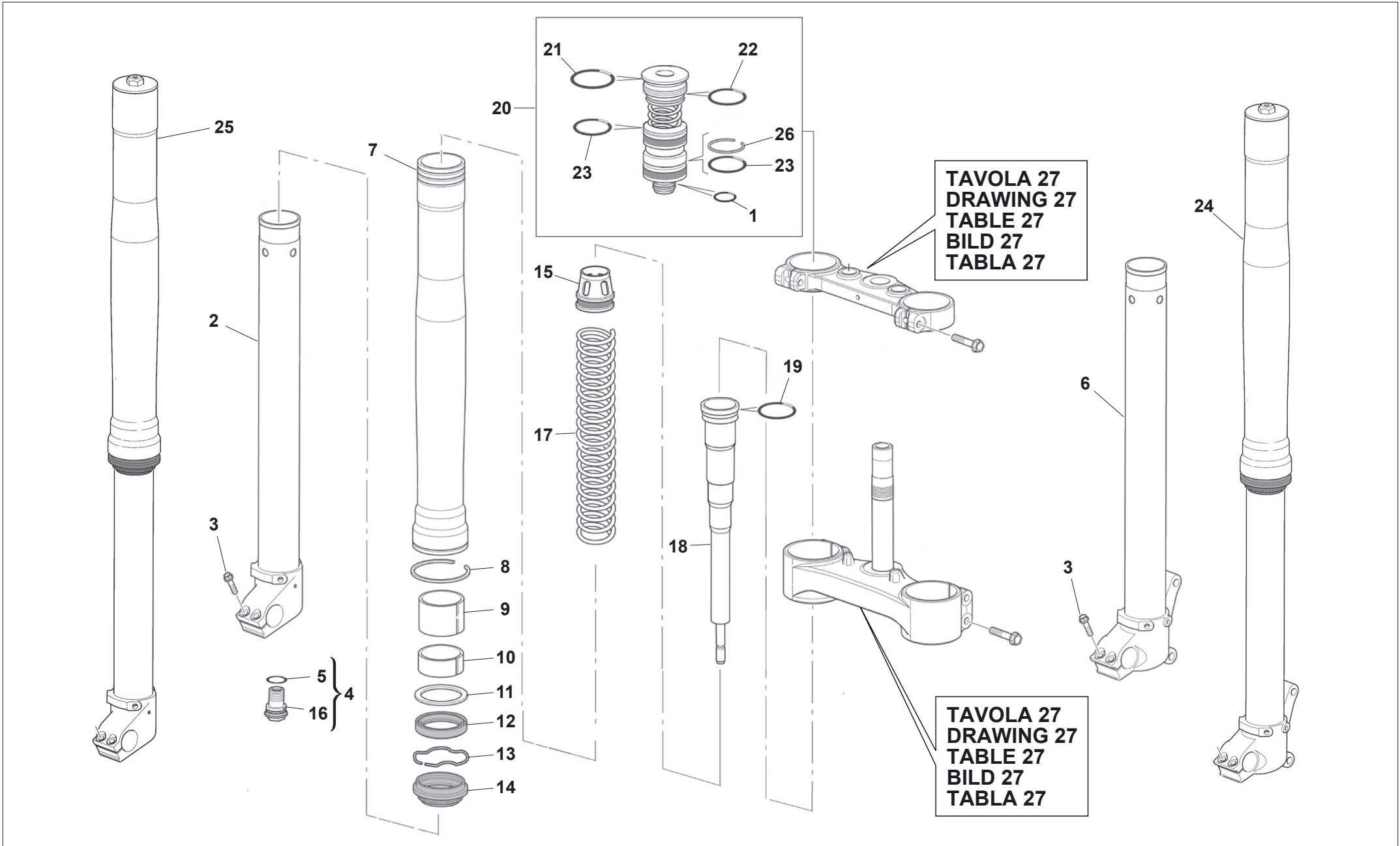
27A

Note Notes Marke Notas	Pos. No. Index Pos.	N. Cod. Code No. Nr. Code Code Nr N. Cod.	Q.tà Q.ty Q.te M.ge C.ad	DENOMINAZIONE	NAME	DESIGNATION	BESHREIBUNG	DENOMINACION	Validità Validity Validité Gültig Validez
	1	8000H2679	2	ANELLO O-RING	O-RING	JOINT TORIQUE	O-RING	JUNTA TORICA	
	2	8000H2658	1	STELO FORCELLA DESTRO	FORK INNER TUBE RH	TIGE FOURCHE DROITE	GABELSTANGE, RECHTS	CANA HORQUILLA DERECHO	
	3	8000H2671	4	VITE	SCREW	VIS	SCHRAUBE	TORNILLO	
	4	8000H2670	2	REGISTRO ESTENSIONE	EXTENTION ADJUSTER	REGLAGE	GLEITREGISTER	REGULATION EXTENSION	
	5	8000H2678	2	ANELLO O-RING	O-RING	JOINT TORIQUE	O-RING	JUNTA TORICA	
	6	8000H2657	1	STELO FORCELLA SINISTRO	FORK INNER TUBE LH	TIGE FOURCHE GAUCHE	GABELSTANGE, LINKS	CANA HORQUILLA IZQUERDO	
	7	8000H2656	2	FODERO FORCELLA	FORK OUTER TUBE	FOURREAU FOURCHE	GABEL HUELSE	FUNDA HORQUILLA	
	8	8000H2672	2	ANELLO DI FERMO	RING, STOPPER	BAGUE ARRET	STOPRING	ANILLO TOPE	
	9	8000H2659	2	BOCCOLA SCORRIMENTO	BUSHING-FRONT FORK, SLIDE	DOUILLE COULISSEMENT	GLEITBUCHSE	CASQUILLO DESLIZAMIENTO	
	10	8000H2660	2	BOCCOLA SCORRIMENTO	BUSHING-FRONT FORK, SLIDE	DOUILLE COULISSEMENT	GLEITBUCHSE	CASQUILLO DESLIZAMIENTO	
	11	8000H2661	2	RONDELLA	WASHER	RONDELLE	SCHEIBE	ARANDELA	
	12	8000H2662	2	PARAOLIO FORCELLA	SEAL OIL, FORK	BAGUE D'ETANCHEITE, FOURCHE	GABELDICHRING	RETEN ACEITE, HORQUILLA	
	13	8000H2663	2	ANELLO DI FERMO	RING, STOPPER	BAGUE ARRET	STOPRING	ANILLO TOPE	
	14	8000H2664	2	PARAPOLVERE FORCELLA	SEAL, DUST FRONT FORK	COIFFE CACHE-POUSSIÈRE FOURCHE	STAUBSCHUTZHAUBE, GABEL	CAPUCHON GUARDAPOLVO HORQUILLA	
	15	8000H7701	2	BOCCOLA	BUSH	DOUILLE	BUCHSE	BUJE	
	16	8000H2676	2	MOZZETTO	BOSS	MOYEU	NABE	CUBO	
	17	8000H2685	2	MOLLA FORCELLA K=4,8 N/MM	SPRING, FRONT FORK	RESSORT FOURCHE	FEDER, VORDERGABEL	MUELLE HORQUILLA	
	18	8000H7699	2	POMPANTE FORCELLA	CYLINDER COMP FRONT FORK	CARTUOCHE AMORTISSEMENT	DAEMPFUNGSSELEMENT	CARTUCHO AMORTIGUACION	
	19	8000H2673	2	ANELLO O-RING	O-RING	JOINT TORIQUE	O-RING	JUNTA TORICA	
	20	8000H7700	2	VALVOLA COMPRESIONE	VALVE COMPRESSION	SOUPAPE COMPRESSION	KOMPRESSION VENTIL	VALVULA COMPRESION	
	21	8000H2674	2	ANELLO O-RING	O-RING	JOINT TORIQUE	O-RING	JUNTA TORICA	
	22	8000H2677	2	ANELLO O-RING	O-RING	JOINT TORIQUE	O-RING	JUNTA TORICA	
	23	8000H2683	4	ANELLO O-RING	O-RING	JOINT TORIQUE	O-RING	JUNTA TORICA	
	24	8000H7053	1	GAMBA FORCELLA SINISTRA	FRONT CUSHION ASSY LEFT	JAMBE FOURCHE GAUCHE	GABELBEIN, LINKS	PIERNA HORQUILLA IZQUERDA	
	25	8000H7054	1	GAMBA FORCELLA DESTRA	FRONT CUSHION ASSY RIGHT	JAMBE FOURCHE DROIT	GABELBEIN, RECHTS	PIERNA HORQUILLA DERECHA	
	26	8000H2681	2	ANELLO DI FERMO	RING, STOPPER	BAGUE ARRET	STOPRING	ANILLO TOPE	

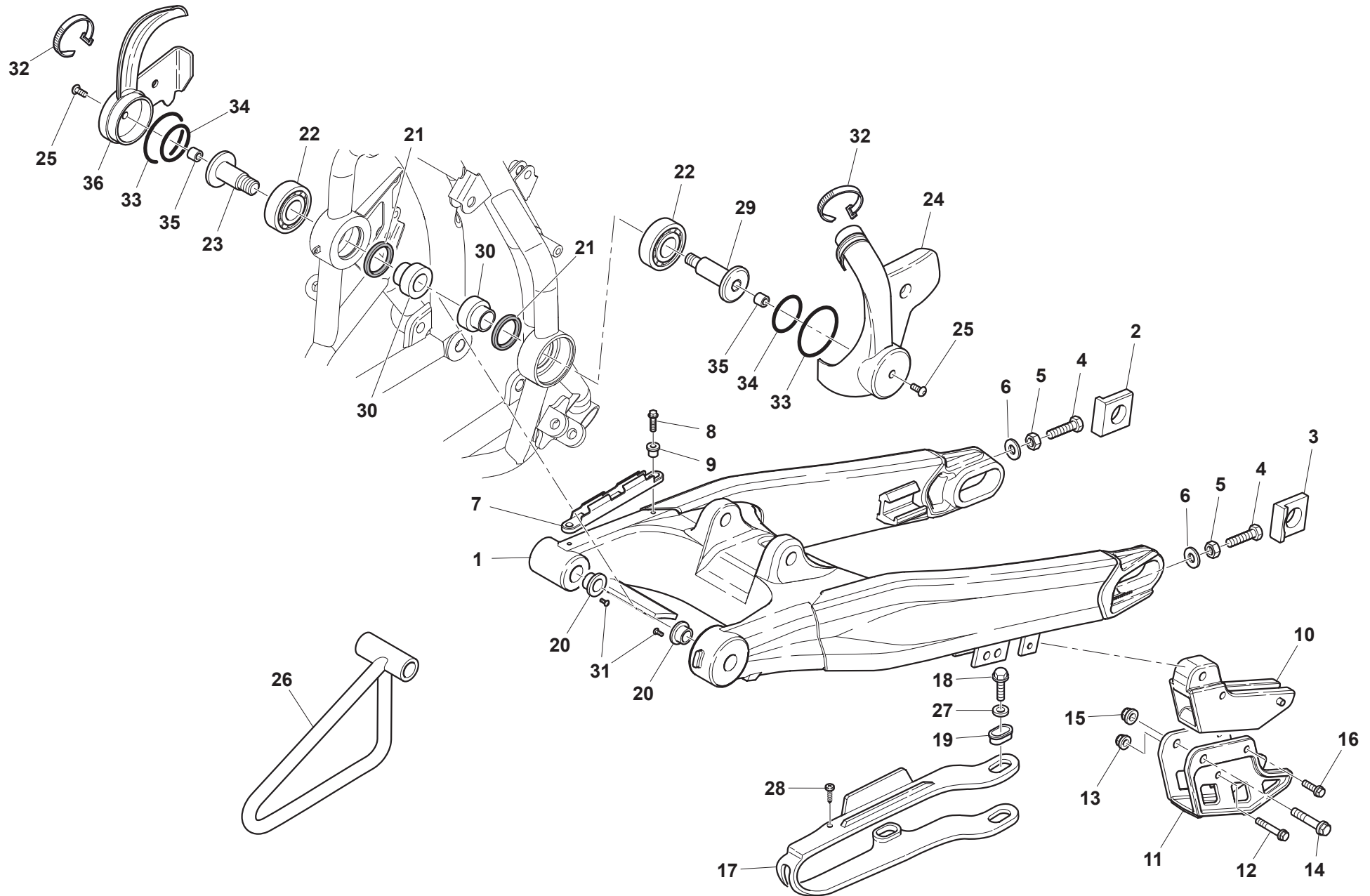

**FORCELLONE POSTERIORE- REAR SWING ARM-
FOURCHE ARRIERE - HINTERGABEL
HORQUILLA TRASERA**
TAVOLA - DRAWING
TABLE - BILD - TABLA

28

Note Notes Marke Notas	Pos. No. N. Index Pos.	N. Cod. Code No. Nr. Code Code Nr N. Cod.	Q.tà Q.ty M.ge C.ad	DENOMINAZIONE	NAME	DESIGNATION	BESHREIBUNG	DENOMINACION	Validità Validity Validité Gültig Validez
	1	8000H3158	1	FORCELLONE	REAR SWING ARM	BRAS OSCILLANT	HINTERE SCHWINGARM	BASCULANTE	
	2	800096944	1	TENDICATENA DESTRO	ADJUSTER, CHAIN RH	TENDEUR CHAINE DROIT	KETTENSPELLER RECHTS	TENSIONADOR CADENA DERECHO	
	3	800096941	1	TENDICATENA SINISTRO	ADJUSTER, CHAIN LH	TENDEUR CHAINE GAUCHE	KETTENSPELLER LINKS	TENSIONADOR CADENA IZQUERDO	
	4	ZC0061121	2	VITE TE M8X1,25	SCREW TE M8X1.25	VIS TE M8X1,25	SCHRAUBE TE M8X1,25	TORNILLO TE M8X1,25	
	5	Z00017810	2	DADO M8X1,25 H8 CH12	NUT M8X1.25 H8 CH12	ECROU M8X1,25 H8 CH12	MUTTER M8X1,25 H8 CH12	TUERCA M8X1,25 H8 CH12	
	6	Z00008536	2	RONDELLA 13X8,4X2	WASHER 13X8.4X2	RONDELLE 13X8,4X2	SCHEIBE 13X8,4X2	ARANDELA 13X8,4X2	
	7	8000B1166	1	GUIDA TUBO FRENO	CLAMP, BRAKE HOSE	GUIDE TUYAU FREIN	FUEHRUNG, BREMSSCHLAUCH	GUIA MANGUERA FRENO	
	8	Z00020536	2	VITE AUTOFILETTANTE 4,8X13	SCREW SELF-TAPPING 4.8X13	VIS TARAUD 4,8X13	GEWINDESCHRAUBE 4,8X13	TORNILLO AUTOROSCANTE 4,8X13	
	9	800069282	2	BOCCOLA 14X7X5,25 MM	BUSH 14X7X5.25 MM	DOUILLE 14X7X5,25 MM	BUCHSE 14X7X5,25 MM	CASQUILLO 14X7X5,25 MM	
	10	800072868	1	CRUNA CATENA	GUIDE, CHAIN	GUIDE CHAINE	KETTENFUEHRUNG	GUIA CADENA	
	11	8000H3161	1	SUPPORTO CRUNA CATENA	COVER, THRUST	SUPPORT GUIDE CHAINE	HALTER, KETTENFUEHRUNG	SOPORTE GUIA CADENA	
	12	Z00062731	1	VITE TEF M6X1X45	SCREW TEF M6X1X45	VIS TEF M6X1X45	SCHRAUBE TEF M6X1X45	TORNILLO TEF M6X1X45	
	13	Z00044240	1	DADO AUTOBLOCCANTE M6X1 CH10	NUT, SELF LOCKING M6X1 CH10	ECROU AUTOBLOQUANT M6X1 CH10	SELBSTSPERRENDE MUTTER M6X1 CH10	TUERCA AUTOBLOQUEANTE M6X1 CH10	
	14	Z00062795	1	VITE TEF M8X1,25X50 CH12	SCREW TEF M8X1.25X50 CH12	VIS TEF M8X1,25X50 CH12	SCHRAUBE TEF M8X1,25X50 CH12	TORNILLO TEF M8X1,25X50 CH12	
	15	Y00043928	1	DADO AUTOBLOCCANTE M8X1,25 H8 CH12	NUT, SELF LOCKING M8X1.25	ECROU AUTOBLOQUANT M8X1,25	SELBSTSPERRENDE MUTTER M8X1,25	TUERCA AUTOBLOQUEANTE M8X1,25	
	16	Z00062725	1	VITE TEF M6X1X10 CH8	SCREW TEF M6X1.00X10 CH8	VIS TEF M6X1,00X10 CH8	SCHRAUBE TEF M6X1,00X10 CH8	TORNILLO TEF M6X1,00X10 CH8	
	17	8000H6253	1	PATTINO SCORRICATENA FORCELLONE	BUFFER, CHAIN TOUCH DEFENSE	PATIN PROTECTEUR BRAS OSCILLANT	KETTENGLEITFUEHRUNG	PATIN DESLIZAMIENTO CADENA	
	18	ZB0020536	4	VITE AUTOFILETTANTE TE 5X20	SCREW SELF-TAPPING TE 5X20	VIS TARAUD TE 5X20	GEWINDESCHRAUBE TE 5X20	TORNILLO AUTOROSCANTE TE 5X20	
	19	8000H3033	4	SCODELLINO	CUP	COUPELLE	EINSTELLE	COPELA	
	20	8000H3932	2	BOCCOLA FILETTATA M12X1,25	THREATED BUSH M12X1,25	DOUILLE FILETEE M12X1,25	GEWINDBUECHSE M12X1,25	CASQUILLO FILETADO M12X1,25	
	21	800086137	2	PARAOLIO 34X26X4	SEAL, OIL 34X26X4	BAGUE D'ETANCHEITE 34X26X4	WELLENDICHRING 34X26X4	RETEN ACEITE 34X26X4	
	22	8000H3080	2	CUSCINETTO A RULLI	BEARING, NEEDLE	ROULEMENT A ROULEAUX	ROLLENLAGER	COJINETE DE RODILLOS	
	23	8000H3931	1	PERNO FORCELLONE DESTRO	AXLE REAR SWING ARM RH	AXE BRAS OSCILLANT DROIT	SCHWINGENACHSE, RECHTS	PERNO BASCULANTE DERECHO	
	24	8000H3983	1	PROTEZIONE TELAIO SINISTRA	GUARD, FRAME LH	PROTECTION CADRE GAUCHE	RAHMENSCHUTZ LINKS	PROTECCION BASTIDOR IZQUERDA	
	25	Y00053876	2	VITE TSPEI M6X1X25	SCREW TSPEI M6X1X25	VIS TSPEI M6X1X25	SCHRAUBE TSPEI M6X1X25	TORNILLO TSPEI M6X1X25	
	26	800074016	1	CAVALLETTO DI SERVIZIO	STAND	SUPPORT	STAENDER	CABALLETE	
	27	Z00036137	4	RONDELLA 11X5,5X1,5 MM	WASHER 11X5.5X1,5 MM	RONDELLE 11X5,5X1,5 MM	SCHEIBE 11X5,5X1,5 MM	ARANDELA 11X5,5X1,5 MM	
	28	ZE0084658	1	VITE AUTOFILETTANTE TE 5X40	SCREW SELF-TAPPING TE 5X40	VIS TARAUD TE 5X40	GEWINDESCHRAUBE TE 5X40	TORNILLO AUTOROSCANTE TE 5X40	
	29	8A00H3931	1	PERNO FORCELLONE SINISTRO	AXLE REAR SWING ARM LH	AXE BRAS OSCILLANT GAUCHE	SCHWINGENACHSE, LINKS	PERNO BASCULANTE IZQUERDO	
	30	8000H2650	2	BOCCOLA FORCELLONE	BUSHING, SWING ARM	DOUILLE, BRAS OSCILLANT	HULSE, SCHWINGE	COLLAR BASCULANTE	
	31	8000H5785	2	VITE TSEI M4X12	SCREW TSEI M4X12	VIS TSEI M4X12	SCHRAUBE TSEI M4X12	TORNILLO TSEI M4X12	
	32	800056444	2	FASCETTA 188 MM	CLAMP 188 MM	COLLIER 188 MM	SHELLE 188 MM	ABRAZADERA 188 MM	
	33	8000H5082	2	ANELLO O-RING 44,17X1,78	O-RING 44,17X1,78	JOINT TORIQUE 44,17X1,78	O-RING 44,17X1,78	JUNTA TORICA 44,17X1,78	

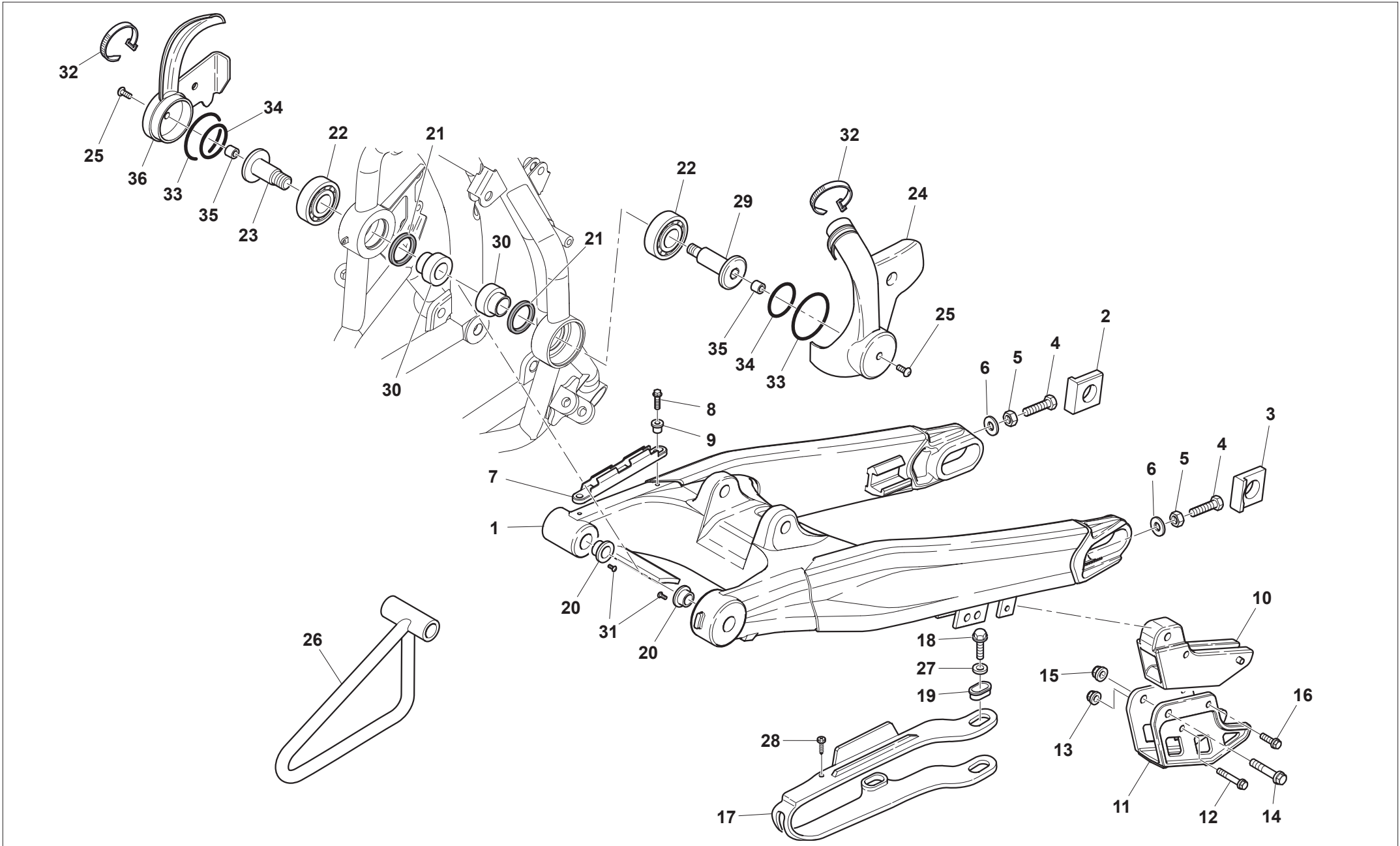

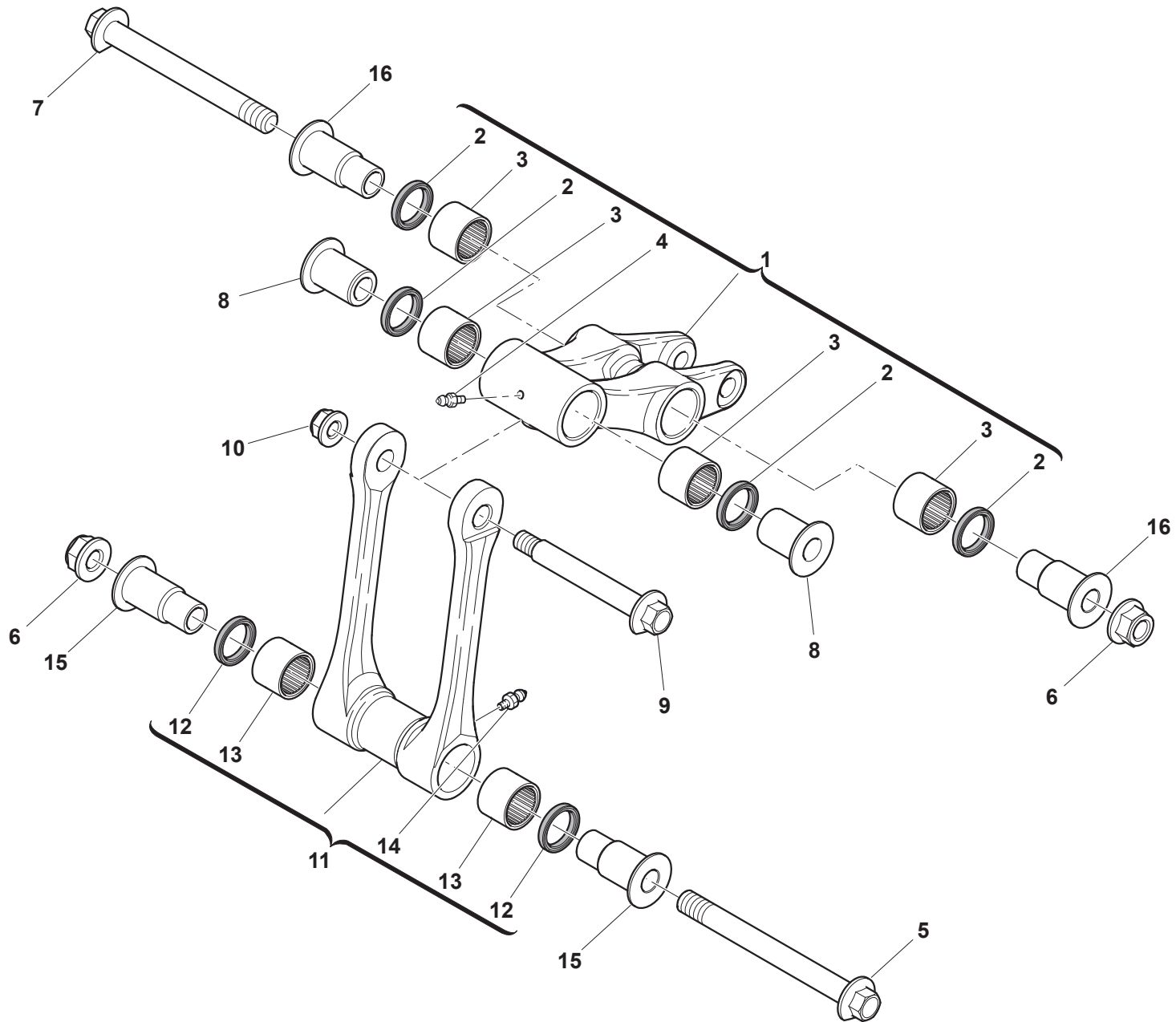

LEVERAGGI SOSPENSIONE POSTERIORE - REAR SUSPENSION LINKAGE
LEVIER SUSPENSION ARRIERE - HEBELWERK HINTERHAUFHANGUNG
PALANCA SUSPENSION TRASERA

TAVOLA - DRAWING
TABLE - BILD - TABLA

29

Note Notes Marke Notas	Pos. No. N. Index Pos.	N. Cod. Code No. Nr. Code Code Nr N. Cod.	Q.tà Q.ty Q.te M.ge C.ad	DENOMINAZIONE	NAME	DESIGNATION	BESHREIBUNG	DENOMINACION	Validità Validity Validité Gültig Validez
	1	8000H2365	1	BILANCIERE SOSPENSIONE POSTERIORE	SWINGARM, CUSHION RELAY	CULBUTEUR SUSPENSION ARRIERE	KIPPSCHWINGE, HINTEN FEDERUNG	BRAZO SUSPENSION TRASERO	
	2	800032065	4	PARAOLIO 26X20X4	SEAL, OIL 26X20X4	BAGUE D'ETANCHEITE 26X20X4	WELLENDICHTRING 26X20X4	RETEN ACEITE 26X20X4	
	3	800042781	4	ASTUCCIO A RULLI HK2020	BEARING, NEEDLE HK2620	ROULEMENT A AIGUILLES HK2620	NADELLAGER HK2620	COJINETE DE AGUJAS HK2620	
	4	800001412	1	INGRASSATORE M6X1	NIPPLE, GREASE M6X1	GRAISSEUR M6X1	SCHMIERNIPPEL M6X1	NIPLE GRASERA M6X1	
	5	Y000B0240	1	VITE M12X1,25X122	SCREW M12X1,25X122	VIS M12X1,25X122	SCHRAUBE M12X1,25X122	TORNILLO M12X1,25X122	
	6	Z00042023	2	DADO M12X1,25	NUT M12X1,25	ECROU M12X1,25	MUTTER M12X1,25	TUERCA M12X1,25	
	7	YB00B0240	1	VITE M12X1,25X115	SCREW M12X1,25X115	VIS M12X1,25X115	SCHRAUBE M12X1,25X115	TORNILLO M12X1,25X115	
	8	8000B0288	2	SPINOTTO	PIN	GOUJON	BOLZEN	EJE	
	9	8000H3678	1	VITE M10X1,25X92	SCREW M10X1,25X92	VIS M10X1,25X92	SCHRAUBE M10X1,25X92	TORNILLO M10X1,25X92	
	10	Z00042022	1	DADO M10X1,25 H10 CH14	NUT M10X1,25 H10 CH14	ECROU M10X1,25 H10 CH14	MUTTER M10X1,25 H10 CH14	TUERCA M10X1,25 H10 CH14	
	11	8000H3615	1	BIELLA SOSPENSIONE POSTERIORE	ARM RELAY, REAR CUSHION LEVER	BIELLE SUSPENSION ARRIERE	PLEUELSTANGE HINTEN FEDERUNG	BIELA SUSPENSION TRASERA	
	12	800032065	2	PARAOLIO 26X20X4	SEAL, OIL 26X20X4	BAGUE D'ETANCHEITE 26X20X4	WELLENDICHTRING 26X20X4	RETEN ACEITE 26X20X4	
	13	800042781	2	ASTUCCIO A RULLI HK2020	BEARING, NEEDLE HK2620	ROULEMENT A AIGUILLES HK2620	NADELLAGER HK2620	COJINETE DE AGUJAS HK2620	
	14	800001412	1	INGRASSATORE M6X1	NIPPLE, GREASE M6X1	GRAISSEUR M6X1	SCHMIERNIPPEL M6X1	NIPLE GRASERA M6X1	
	15	8000B0241	2	SPINOTTO	PIN	GOUJON	BOLZEN	EJE	
	16	8A00B0241	2	SPINOTTO	PIN	GOUJON	BOLZEN	EJE	



TAVOLA 29
DRAWING 29
TABLE 29
BILD 29
TABLA 29



AMMORTIZZATORE POSTERIORE- REAR SUSPENSION
SUSPENSION ARRIERE- HINTERHAUFHANGUNG
SUSPENSION TRASERA

TAVOLA - DRAWING
TABLE - BILD - TABLA

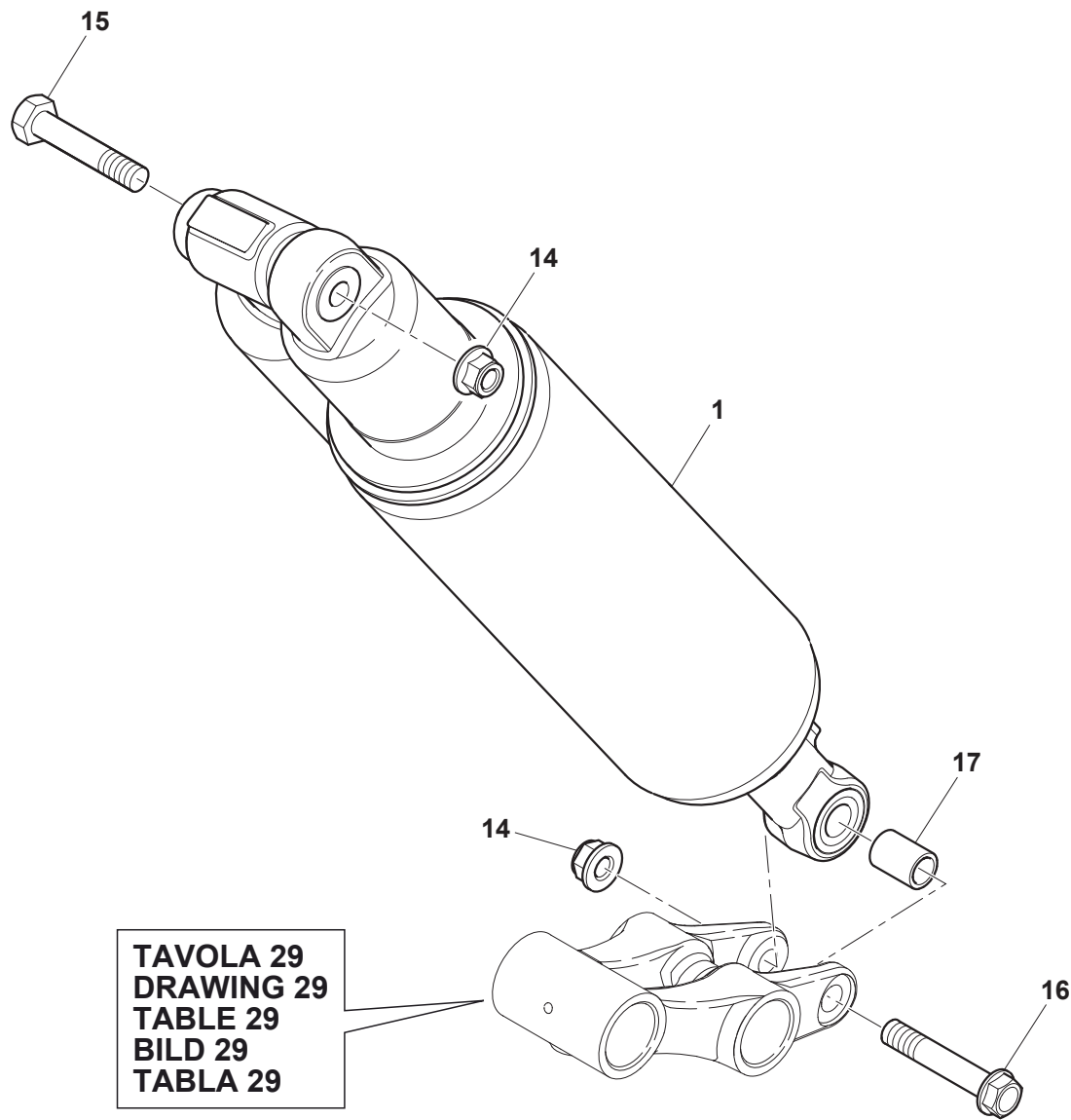
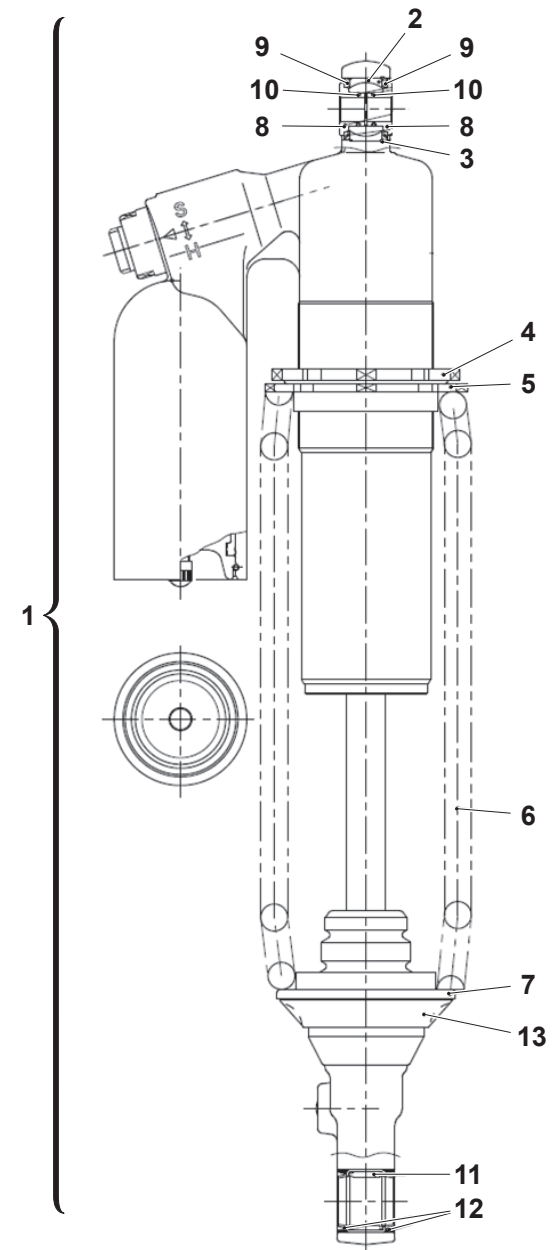
30

Note Notes Marke Notas	Pos. No. N. Index Pos.	N. Cod. Code No. Nr. Code Code Nr N. Cod.	Q.tà Q.ty Q.te M.ge C.ad	DENOMINAZIONE	NAME	DESIGNATION	BESHREIBUNG	DENOMINACION	Validità Validity Validité Gültig Validez
	1	8000H6676	1	AMMORTIZZATORE POSTERIORE	SHOCK ABSORBER, REAR	AMORTISSEUR ARRIERE	HINTERER FEDERBEIN	AMORTIGUADOR TRASERO	
	2	8000H6112	1	BUSSOLA	BUSH	DOUILLE	BUCHSE	BUJE	
	3	8000H6113	1	ANELLO DI FERMO	RING, STOPPER	BAGUE ARRET	STOPRING	ANILLO TOPE	
	4	8000H6114	1	GHIERA	RING NUT	ECROU A BAGUE	RINGMUTTER	VIROLA	
	5	8000H6115	1	CONTROGHIERA	RING NUT	ECROU A BAGUE	RINGMUTTER	VIROLA	
	6	8000H6116	1	MOLLA AMMORTIZZATORE POSTERIORE	SPRING, REAR SHOCK ABSORBER	RESSORT AMORTISSEUR ARRIERE	FEDER HINTERER FEDERBEIN	MUELLE AMORTIGUADOR TRASERO	
	7	8000H6117	1	GHIERA	RING NUT	ECROU A BAGUE	RINGMUTTER	VIROLA	
	8	8000H6118	2	BUSSOLA	BUSH	DOUILLE	BUCHSE	BUJE	
	9	8000H6119	2	PARAPOLVERE	SEAL, DUST	CACHE POUSSIERE	STAUBDICHTUNG	QUITAPOLVO	
	10	8000H6120	2	ANELLO O-RING	O-RING	JOINT TORIQUE	O-RING	JUNTA TORICA	
	11	8000H6121	1	CUSCINETTO AD AGHI	BEARING, NEEDLE	ROULEMENT A AIGUILLES	NADELLAGER	COJINETE DE RODILLOS	
	12	8000H6122	2	PARAPOLVERE	SEAL, DUST	PARE POUSSIERE	STAUBDICHTUNG	GUARDAPOLVO	
	13	8000H7711	1	FONDELLO AMMORTIZZATORE	TANK SUPPORT	SUPPORT RESERVOIR	GASTANKHALTERUNG	SOPORTE DEPOSITO	
	14	Z00042022	2	DADO M10X1,25 H10 CH14	NUT M10X1.25 H10 CH14	ECROU M10X1,25 H10 CH14	MUTTER M10X1,25 H10 CH14	TUERCA M10X1,25 H10 CH14	
	15	ZD0062797	1	VITE TE M10X1,25X47 CH14	SCREW TE M10X1.25X47 CH14	VIS TE M10X1,25X47 CH14	SCHRAUBE TE M10X1,25X47 CH14	TORNILLO TE M10X1,25X47 CH14	
	16	Z00062572	1	VITE TEF M10X1,25X55 CH14	SCREW TEF M10X1.25X55 CH14	VIS TEF M10X1,25X55 CH14	SCHRAUBE TEF M10X1,25X55 CH14	TORNILLO TEF M10X1,25X55 CH14	
	17	8000A4431	1	SPINOTTO 20X10X25,2	WRIST PIN 20X10X25.2	GOUJON 20X10X25,2	BOLZEN 20X10X25,2	PASADOR 20X10X25,2	

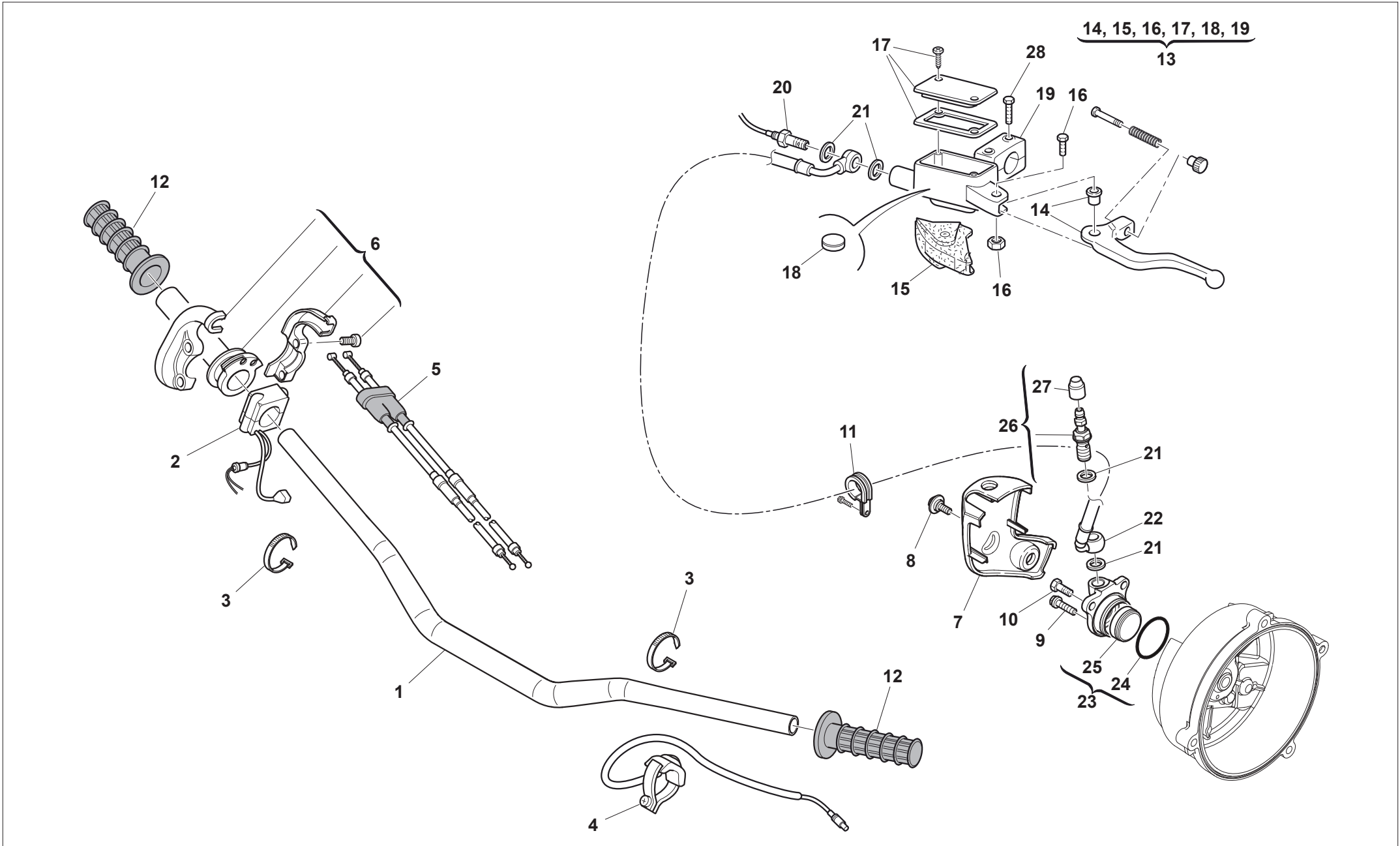

MANUBRIO E COMANDI - HANDLEBAR AND CONTROLS
GUIDON ET COMMANDES - LENKER UND STEUERORGANE
MANILLAR Y MANDOS
TAVOLA - DRAWING
TABLE - BILD - TABLA

31

Note Notes Marke Notas	Pos. No. N. Index Pos.	N. Cod. Code No. Nr. Code Code Nr N. Cod.	Q.tà Q.ty Q.te M.ge C.ad	DENOMINAZIONE	NAME	DESIGNATION	BESHREIBUNG	DENOMINACION	Validità Validity Validité Gültig Validez
	1	80B0A3612	1	MANUBRIO	HANBLEBAR	GUIDON	LENKER	MANILLAR	
	2	8000H3999	1	COMMUTATORE DESTRO	RH SWITCH	COMMUTATEUR DROIT	RECHTER LENKERSCHALTER	CONMUTADOR DERECHO	
	3	800071578	4	FASCETTA 78 MM	CLAMP 78 MM	COLLIER 78 MM	SHELLE 78 MM	ABRAZADERA 78 MM	
	4	8000H4028	1	PULSANTE ENGINE STOP	ENGINE STOP BUTTON	BOUTON ENGINE STOP	KNOPFTASTE ENGINE STOP	PULSADOR ENGINE STOP	
	5	8A00H2115	1	CAVO GAS	CABLE, THROTTLE	CABLE GAZ	GASSEIL	CABLE ACELERADOR	
	6	800098209	1	COMANDO GAS	GRIP, THROTTLE	COMMANDE GAZ	GASSCHALTUNG	MANDO ACELERADOR	
	7	8000H3075	1	COPERCHIO SPINGIFRIZIONE IDRAULICO	COVER	COUVERCLE	DECKEL	CUBIERTA	
	8	8000A8421	1	VITE FLANGIATA M5X8	BOLT, FLANGE M5X8	VIS A EMBASE M5X8	FLANSCHENSCHRAUBE M5X8	TORNILLO CON VALONA M5X8	
	9	ZH0067545	1	VITE TEF M6X1X12 CH8	SCREW TEF M6X1X12 CH8	VIS TEF M6X1X12 CH8	SCHRAUBE TEF M6X1X12 CH8	TORNILLO TEF M6X1X12 CH8	
	10	Z00062727	2	VITE TE M6X1X16 CH8	SCREW TE M6X1X16 CH8	VIS TE M6X1X16 CH8	SCHRAUBE TE M6X1X16 CH8	TORNILLO TE M6X1X16 CH8	
	11	8000H4143	1	FERMATUBO	CLAMP, PIPE	ARRET TUYAU	SCHLAUCHHALTERUNG	BLOQUEO TUBO	
	12	8000H0995	1	COPIA MANOPOLE	HANDGRIP SET	JEU POIGNEES	HANDGRIFFPAAR	JUEGO EMPUNADURAS	
	13	8A00H0884	1	POMPA FRIZIONE	CLUTCH MASTER CYLINDER	MAITRE-CYLINDRE EMBRAYAGE	KUPPLUNGSHAUPTZYLINDER	BOMBA EMBRAGUE	
	14	8000H1982	1	LEVA FRIZIONE	LEVER, CLUTCH	LEVIER EMBRAYAGE	KUPPLUNGSEBEL	PALANCA EMBRAGUE	
	15	8000H1983	1	CAPPUCCIO LEVA FRIZIONE	COVER, L. HANDLE LEVER	CAPUCHON LEVIER EMBRAYAGE	KAPPE, KUPPLUNGSEBEL	CAPUCHON PALANCA EMBRAGUE	
	16	8000H1985	1	PERNO LEVA	BOLT, PIVOT	AXE LEVIER	HEBELBOLZEN	PERNO PALANCA	
	17	8000H1984	1	TAPPO VASCHETTA	CAP, RESERVOIR	BOUCHON, RESERVOIR	TANKPFROPFEN	TAPON DEPOSITO	
	18	800079099	1	ANTIEMULSIONANTE	ANTIEMULSION	ANTIEMULSION	EMULSIONWIDRIGER	ANTIEMULSION	
	19	8000H6000	1	CAVALLOTTO POMPA FRENO	BRACKET, MASTER CYLINDER	BRIDE MAITRE CYLINDRE	KONSOLE, HAUPTBREMSZYLINDER	BRIDA BOMBA FRENO	
	20	8000H5963	1	INTERRUTTORE FRIZIONE	SWITCH, CLUTCH	INTERRUPTEUR EMBRAYAGE	KUPPLUNGSSCHALTER	INTERRUPTOR EMBRAGUE	
	21	800021480	4	RONDELLA 14X10,2X1 MM	WASHER 14X10,2X1 MM	RONDELLE 14X10,2X1 MM	SCHEIBE 14X10,2X1 MM	ARANDELA 14X10,2X1 MM	
	22	8000H5962	1	TUBO FRIZIONE	HOSE, CLUTCH	TUYAU EMBRAYAGE	KUPPLUNGSTEUERUNGSSCHLAUCH	TUBO MANDO EMBRAGUE	
	23	8000A7048	1	COMANDO FRIZIONE IDRAULICO	CYLINDER, CLUTCH PRESSURE	CYLINDRE POUSSEE EMBRAYAGE	KUPPLUNGZYLINDERDRUCH	CILINDRO EMPUJADOR EMBRAGUE	
	24	8000H6010	1	ANELLO O-RING	O-RING	JOINT TORIQUE	O-RING	JUNTA TORICA	
	25	8000H6009	1	PISTONCINO SPINGIFRIZIONE IDRAULICO	CYLINDER KIT, MASTER CLUTCH	GROUPE PISTON CYLINDRE POUSSEE EMBRAYAGE	KOLBEN, KUPPLUNGZYLINDERDRUCH	PISTON CILINDRO EMPUJADOR EMBRAGUE	
	26	8000A3975	1	VITE RACCORDO TUBO OLIO	BOLT, OIL PIPE	VIS FIXATION TUYAU HUILE	FIXIERSCHRAUBE OELSCHLAUCH	TORNILLO FIJACION TUBO ACEITE	
	27	800053259	1	CAPPUCCIO VITE SPURGO	CAP, BLEEDER SCREW	CAPUCHON VIS RENIFLARD	ENTLUEFTUNGSKAPPE	CAPUCHON TORNILLO PURGA PINZA	
	28	Z00062729	2	VITE TEF M6X1X25 CH8	SCREW TEF M6X1X25 CH8	VIS TEF M6X1X25 CH8	SCHRAUBE TEF M6X1X25 CH8	TORNILLO TEF M6X1X25 CH8	

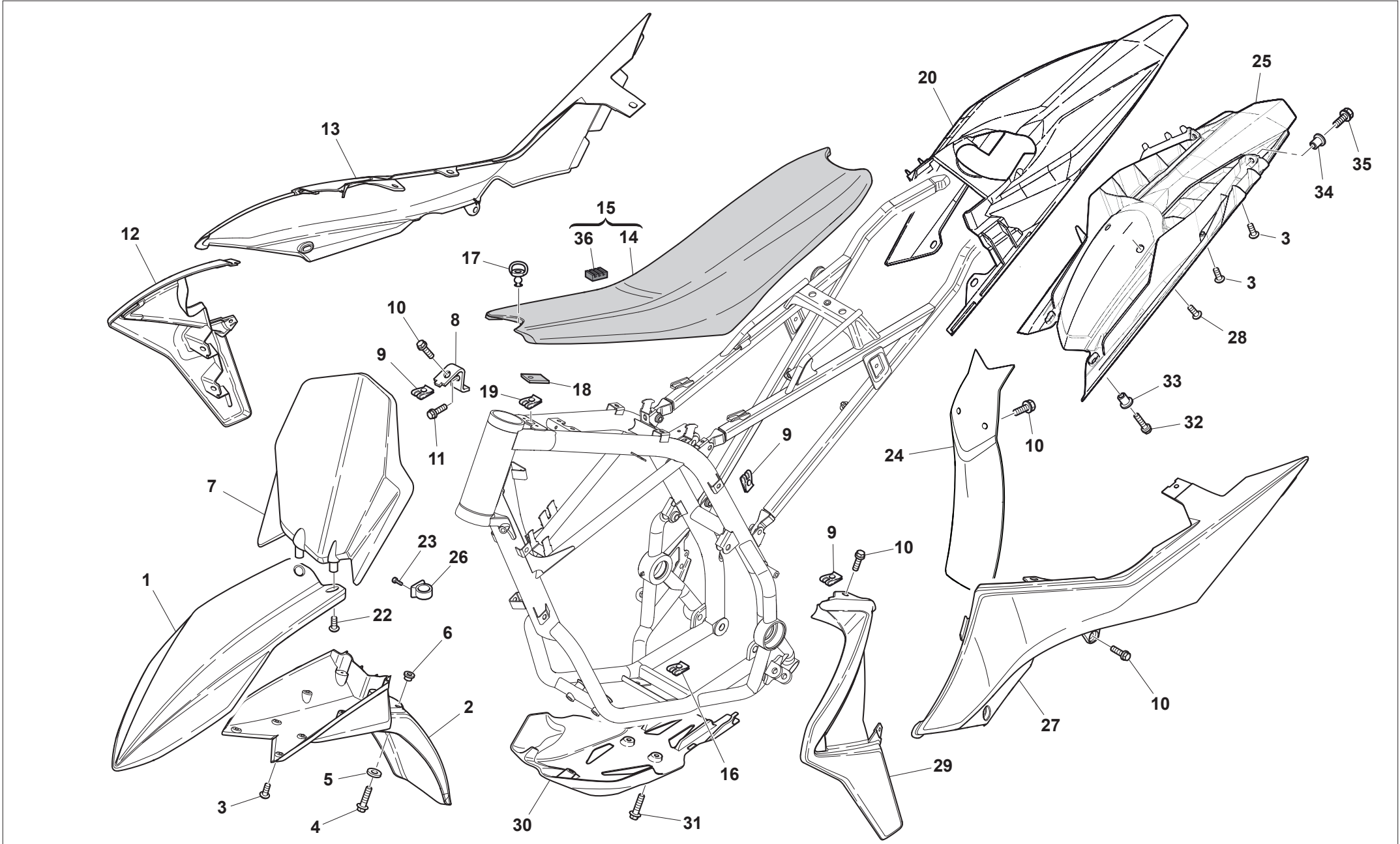

**PANNELLI, PARAFANGHI, SELLA - PANEL, FENDERS, SEAT
PANNEAU, GARDE-BOUES, SIEGE - STREIFEN, KOTFLUGEL, SATTEL
PANELO, GUARDABARROS, SILLIN**

Note Notes Marke Notas	Pos. No. Index Pos.	N. Cod. Code No. Nr. Code Code Nr N. Cod.	Q.tà Q.ty M.ge C.ad	DENOMINAZIONE	NAME	DESIGNATION	BESHREIBUNG	DENOMINACION	Validità Validity Validité Gültig Validez
	1	8000H5008	1	PARAFANGO ANTERIORE	FRONT FENDER	GARDE BOUE AVANT	KOTFLUEGEL VORNE	GUARDABARROS DELANTERO	
	2	8000H3858	1	SEMIPARAFANGO ANTERIORE	EXTENSION, FRONT FENDER	MOULURE GARDE BOUE	KOTFLUEGEL VORNE	GUARDABARROS DELANTERO	
	3	Z00084658	12	VITE AUTOFILETTANTE TCIC 5X16	SCREW SELF-TAPPING TCIC 5X16	VIS TARAUD TCIC 5X16	GEWINDESCHRAUBE TCIC 5X16	TORNILLO AUTOROSCANTE TCIC 5X16	
	4	Z00062729	4	VITE TEF M6X1X25 CH8	SCREW TEF M6X1X25 CH8	VIS TEF M6X1X25 CH8	SCHRAUBE TEF M6X1X25 CH8	TORNILLO TEF M6X1X25 CH8	
	5	Z00048814	4	RONDELLA 18X6,4X2 MM	WASHER 18X6,4X2 MM	RONDELLE 18X6,4X2 MM	SCHEIBE 18X6,4X2 MM	ARANDELA 18X6,4X2 MM	
	6	ZC0069429	4	BOCCOLA 9X7X9,5 MM	BUSH 9X7X4,8 MM	DOUILLE 9X7X4,8 MM	BUCHSE 9X7X4,8 MM	BUJE 9X7X4,8 MM	
	7	8000H3859	1	TABELLA PORTANUMERO ANTERIORE	PLATE, NUMBER	TABLIER PORTE NUMERO	VORNE NUMMERTAFEL	PORTA NUMERO DELANTERO	
	8	8000A4609	1	PIASTRINA	PLATE	PLAQUETTE	PLAETTCHEN	PLETINA	
	9	U00055134	13	DADO ELASTICO M5X0,8	NUT M5X0,8	ECROU M5X0,8	MUTTER M5X0,8	TUERCA M5X0,8	
	10	8A00A8421	18	VITE FLANGIATA M5X12	BOLT, FLANGE M5X12	VIS A EMBASE M5X12	GEFLANSCHSCHRAUBE M5X12	TORNILLO CON VALONA M5X12	
	11	ZE0067997	1	VITE TEF M5X0,8X10 CH8	SCREW TEF M5X0,8X10 CH8	VIS TEF M5X0,8X10 CH8	SCHRAUBE TEF M5X0,8X10 CH8	TORNILLO TEF M5X0,8X10 CH8	
	12	8000H3850	1	CONVOGLIATORE DESTRO	COVER, RADIATOR, RH	OUIE RADIATEUR DROIT	RECHTES LEITBLECH	PROTECTOR RADIADOR DERECHO	
	13	8A00H3852	1	FIANCHETTO DESTRO	COVER FRAME RIGHT	COUVERCLE CADRE DROIT	SEITENDECKEL, RECHTS	CUBIERTA BASTIDOR DERECHA	
	14	8000H3194	1	COPERTINA SELLA	COVER, SEAT	HOUSSE SELLE	SITZBANKUEBERZUG	CUBIERTA ASIENTO	
	15	8000H3191	1	SELLA	SEAT	SELLE	SITZBANK	ASIENTO	
	16	U00046893	3	DADO ELASTICO M6X1	CLIP NUT M6X1	JONC M6X1	KLEMME M6X1	PRESILLA M6X1	
	17	8000H1917	1	PERNO ATTACCO SELLA	PIN, SADDLE	AXE SELLE	SITZACHSE	PERNO ASIENTO	
	18	8000H6598	1	TAMPONE	CUSHION	TAMPON	DAEMPFER	TAMPON	
	19	8000H4000	1	DADO ELASTICO	CLIP NUT	ECROU D' AGRAFE	FEDERMUTTER	TUERCA DE CLIP	
	20	8000H7116	1	PARAFANGO POSTERIORE	FENDER, REAR	GARDE-BOUE ARRIERE	KOTFLUEGEL HINTEN	GUARDABARROS TRASERO	
	22	8000H4036	2	VITE AUTOFILETTANTE 6X25 CH8	SCREW SELF-TAPPING 6X25 CH8	VIS TARAUD 6X25 CH8	GEWINDESCHRAUBE 6X25 CH8	TORNILLO AUTOROSCANTE 6X25 CH8	
	23	ZA0037283	2	VITE AUTOFILETTANTE AB 3,5X13	SCREW SELF-TAPPING AB 3,5X13	VIS TARAUD AB 3,5X13	GEWINDESCHRAUBE AB 3,5X13	TORNILLO AUTOROSCANTE AB 3,5X13	
	24	8000H7117	1	PROTEZIONE AMMORTIZZATORE	COVER, SHOCK ABSORBER	PROTECTION AMORTISSEUR	SCHUTZ, FEDERBEIN	PROTECCION AMORTIGUADOR TRASERO	
	25	8000H6796	1	PARAFANGO POSTERIORE INTERNO	FENDER REAR, INNER	GARDE-BOUE ARRIERE INTERIEUR	KOTFLUEGEL HINTEN, INNERER	GUARDABARROS TRASERO INTERIOR	
	26	8000A0864	1	GUIDA TUBO FRENO ANTERIORE	GUIDE, FRONT BRAKE HOSE	GUIDE TUYAU FREIN AVANT	BREMSSCHLAUCH VORNEFUEHRUNG	GUIA MANGUERA FRENO DELANTERO	
	27	8A00H3853	1	FIANCHETTO SINISTRO	COVER FRAME LEFT	COUVERCLE CADRE GAUCHE	SEITENDECKEL, LINKS	CUBIERTA BASTIDOR IZQUERDA	
	28	8000A8421	2	VITE FLANGIATA M5X8	BOLT, FLANGE M5X8	VIS A EMBASE M5X8	FLANSCHSCHRAUBE M5X8	TORNILLO CON VALONA M5X8	
	29	8000H3851	1	CONVOGLIATORE SINISTRO	COVER, RADIATOR, LH	OUIE RADIATEUR GAUCHE	LINKES LEITBLECH	DEFLECTOR AIRE IZQUERDO	
	30	8000H3981	1	PARAMOTORE	GUARD, ENGINE	PROTECTION MOTEUR	SCHUTZ, MOTOR	PROTECCION MOTOR	
	31	8A00A8423	3	VITE FLANGIATA M6X12	BOLT, FLANGE M5X12	VIS A EMBASE M5X12	GEFLANSCHSCHRAUBE M5X12	TORNILLO CON VALONA M5X12	
	32	ZJ0067997	2	VITE TEF M5X25 CH8	SCREW TEF M5X25 CH8	VIS TEF M5X25 CH8	SCHRAUBE TEF M5X25 CH8	TORNILLO TEF M5X25 CH8	
	33	8C0069282	2	DISTANZIALE 14X7X5,5 MM	SPACER 14X7X5,5 MM	ENTRETOISE 14X7X5,5 MM	ABSTANDHALTER 14X7X5,5 MM	DISTANCIADOR 14X7X5,5 MM	
	34	8000H1735	2	BOCCOLA FLANGIATA	BUSH WITH COLLAR	DOUILLE BRIDEE	GEFLANSCHBUCHSE	CASQUILLO REBORDEADO	

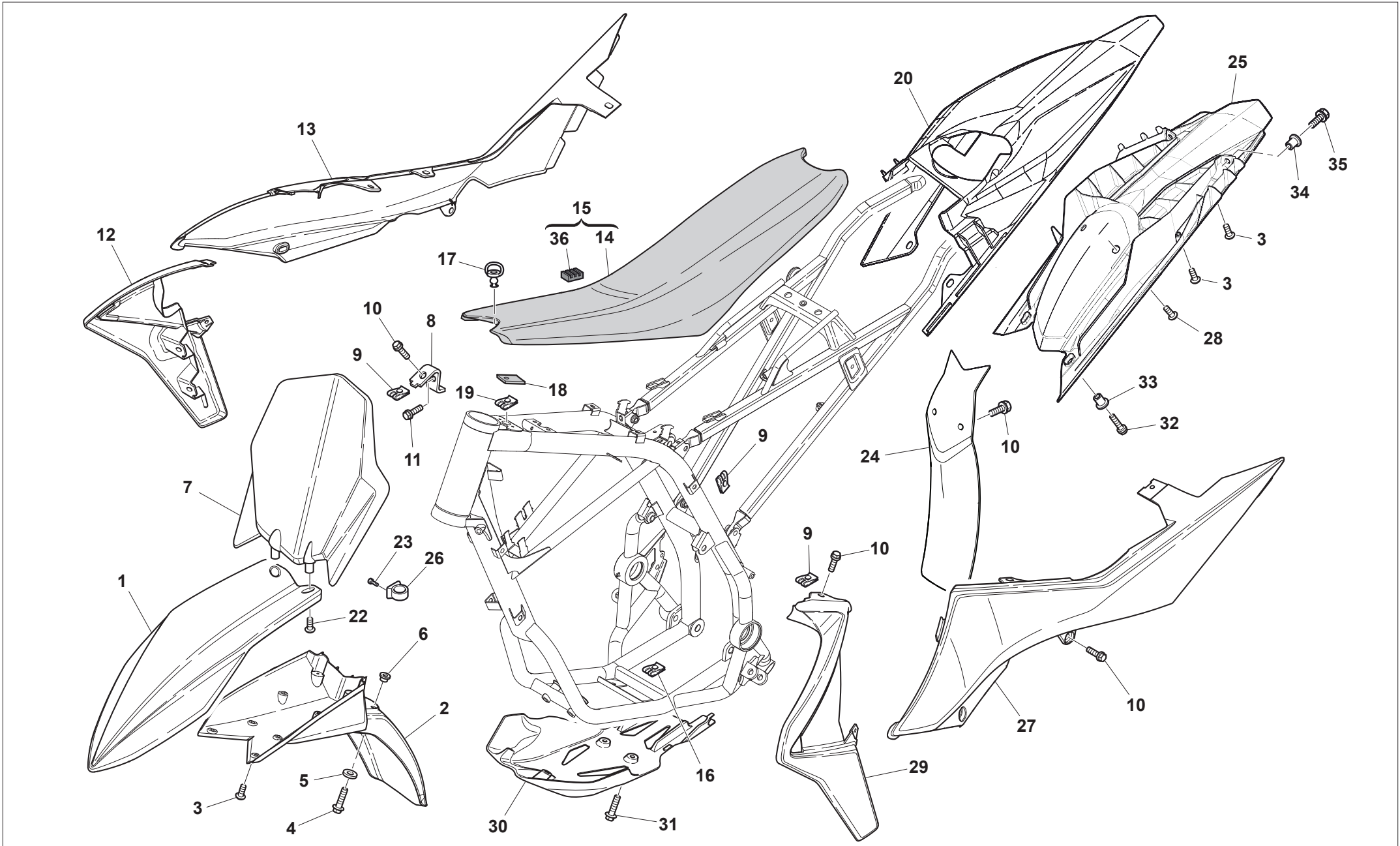



TAVOLA 24A
DRAWING 24A
TABLE 24A
BILD 24A
TABLA 24A

SERBATOIO CARBURANTE - GAS TANK
RESERVOIR CARBURANT - KRAFTSTOFFBEHALTER
DEPOSITO GASOLINA
TAVOLA - DRAWING
TABLE - BILD - TABLA

33

Note Notes Marke Notas	Pos. No. Index Pos.	N. Cod. Code No. Nr. Code Code Nr N. Cod.	Q.tà Q.ty Q.te M.ge C.ad	DENOMINAZIONE	NAME	DESIGNATION	BESHREIBUNG	DENOMINACION	Validità Validity Validité Gültig Validez
	1	8000H5786	1	TAPPO SERBATOIO CARBURANTE	CAP SET, FUEL TANK	BOUCHON RESERVOIR CARBURANT	VERSCHLUSS, KRAFTSTOFFTANK	TAPON DEPOSITO CARBURANTE	
	2	800056381	1	GUARNIZIONE TAPPO SERBATOIO	GASKET, CAP	JOINT, BOUCHON RESERVOIR	DICHTUNG, VERSCHLUSSKAPPE	JUNTA TAPON DEPOSITO	
	3	8000H5028	1	SERBATOIO CARBURANTE	FUEL TANK	RESERVOIR CARBURANT	KRAFTSTOFFTANK	DEPOSITO CARBURANTE	
	4	8000A8407	2	GOMMINO	GROMMET	CAOUTCHOUC	GUMMITEILE	GOMA	
	5	8000H3166	2	INSERTO FILETTATO M6	THREADED INSERT M6	INSERTION FILETE M6	GEWINDEINSATZ M6	ROSCA ROSCADA M6	
	6	Z00062727	2	VITE TE M6X1X16 CH8	SCREW TE M6X1X16 CH8	VIS TE M6X1X16 CH8	SCHRAUBE TE M6X1X16 CH8	TORNILLO TE M6X1X16 CH8	
	7	8000H4774	2	RUBINETTO CARBURANTE	FUEL COCK	ROBINET ESSENCE	KRAFTSTOFFHAHN	GRIFO GASOLINA	
	8	8000A8278	2	ANELLO O-RING 2X11	O-RING 2X11	JOINT TORIQUE 2X11	O-RING 2X11	JUNTA TORICA 2X11	
	9	ZA0067997	5	VITE TEF M5X0,8X16 CH8	SCREW TEF M5X0,8X16 CH8	VIS TEF M5X0,8X16 CH8	SCHRAUBE TEF M5X0,8X16 CH8	TORNILLO TEF M5X0,8X16 CH8	
	10	Z00037745	4	VITE TCIC AUTOFILETTANTE 5,5X19	SCREW, TAPPING TCIC 5,5X19	VIS TARAUD TCIC 5,5X19	GEWINDESCHRAUBE TCIC 5,5X19	TORNILLO AUTOROSCANTE TCIC 5,5X19	
	11	80A042349	5	FASCETTA	CLAMP	COLLIER	KLAMMER	ABRAZADERA	
	12	8000H4790	1	TUBO CARBURANTE GOMMA 7X12	HOSE, RUBBER 7X12	TUYAU EN CAOUTCHOUC 7X12	GUMMISCHLAUCH 7X12	MANGUERA GOMA 7X12	
	13	8000H3165	1	POMPA CARBURANTE	PUMP, FUEL	POMPE CARBURANT	KRAFTSTOFFPUMPE	BOMBA CARBURANTE	
	14	8000H3155	1	ANELLO O-RING	O-RING	JOINT TORIQUE	O-RING	JUNTA TORICA	
	15	8000H3930	1	TUBO CARBURANTE ALTA PRESSIONE	HOSE, FUEL HIGH PRESSURE	TUYAU CARBURANT HAUTE PRESSION	KRAFTSTOFFSCHLAUCH HOCHDRUCK	TUBO CARBURANTE ALTA PRESION	
	16	8000H1981	1	FASCETTA 13X5 MM	CLAMP 13X5 MM	COLLIER 13X5 MM	SHELLE 13X5 MM	ABRAZADERA 13X5 MM	
	17	8A00H2956	1	SERBATOIO CARBURANTE SECONDARIO	FUEL TANK, SECONDARY	RESERVOIR CARBURANT SECONDAIRE	SEKUNDAEREKRAFTSTOFFTANK	DEPOSITO CARBURANTE SECUNDARIO	
	18	8000H3143	1	GOMMINO	GROMMET	CAOUTCHOUC	GUMMITEILE	GOMA	
	19	8000H4654	2	DISTANZIALE	SPACER	ENTRETOISE	ABSTANDHALTER	DISTANCIADOR	
	20	8000H4479	2	GOMMINO	GROMMET	CAOUTCHOUC	GUMMITEILE	GOMA	
	21	ZD0067545	1	VITE TEF M6X1X60 CH8	SCREW TEF M6X1X60 CH8	VIS TEF M6X1X60 CH8	SCHRAUBE TEF M6X1X60 CH8	TORNILLO TEF M6X1X60 CH8	
	22	62N015673	3	RONDELLA IN ALLUMINIO 11X6,1X1	WASHER, ALUMINIUM 11X6,1X1	RONDELLE EN ALUMINIUM 11X6,1X1	ALUMINIUM SCHEIBE 11X6,1X1	ARANDELA DE ALUMINIO 11X6,1X1	
	23	8000A4031	3	RACCORDO FILETTATO	THREADED NIPPLE	RACCORD FILETEE	HOHLSCHRAUBE	EMPALME ROSCADO	
	24	947200035	3	TUBO IN GOMMA 5X9	HOSE, RUBBER 5X9	TUYAU EN CAOUTCHOUC 5X9	GUMMISCHLAUCH 5X9	MANGUERA GOMA 5X9	
	25	8000A5925	1	VALVOLA VENTILAZIONE	VALVE	SOUPAPE	VENTIL	VALVULA	
	26	800018922	2	FASCETTA ELASTICA IMA10712 10 MM	SPLIT RING IMA10712 10 MM	ANNEAU RESSORT IMA10712 10 MM	SPRENGRING IMA10712 10 MM	ABRAZADERA ELASTICA IMA10712 10 MM	
	27	8D0067610	1	FASCETTA	CLAMP	COLLIER	KLAMMER	ABRAZADERA	
	28	8000H5731	1	DISTANZIALE	SPACER	ENTRETOISE	ABSTANDHALTER	DISTANCIADOR	

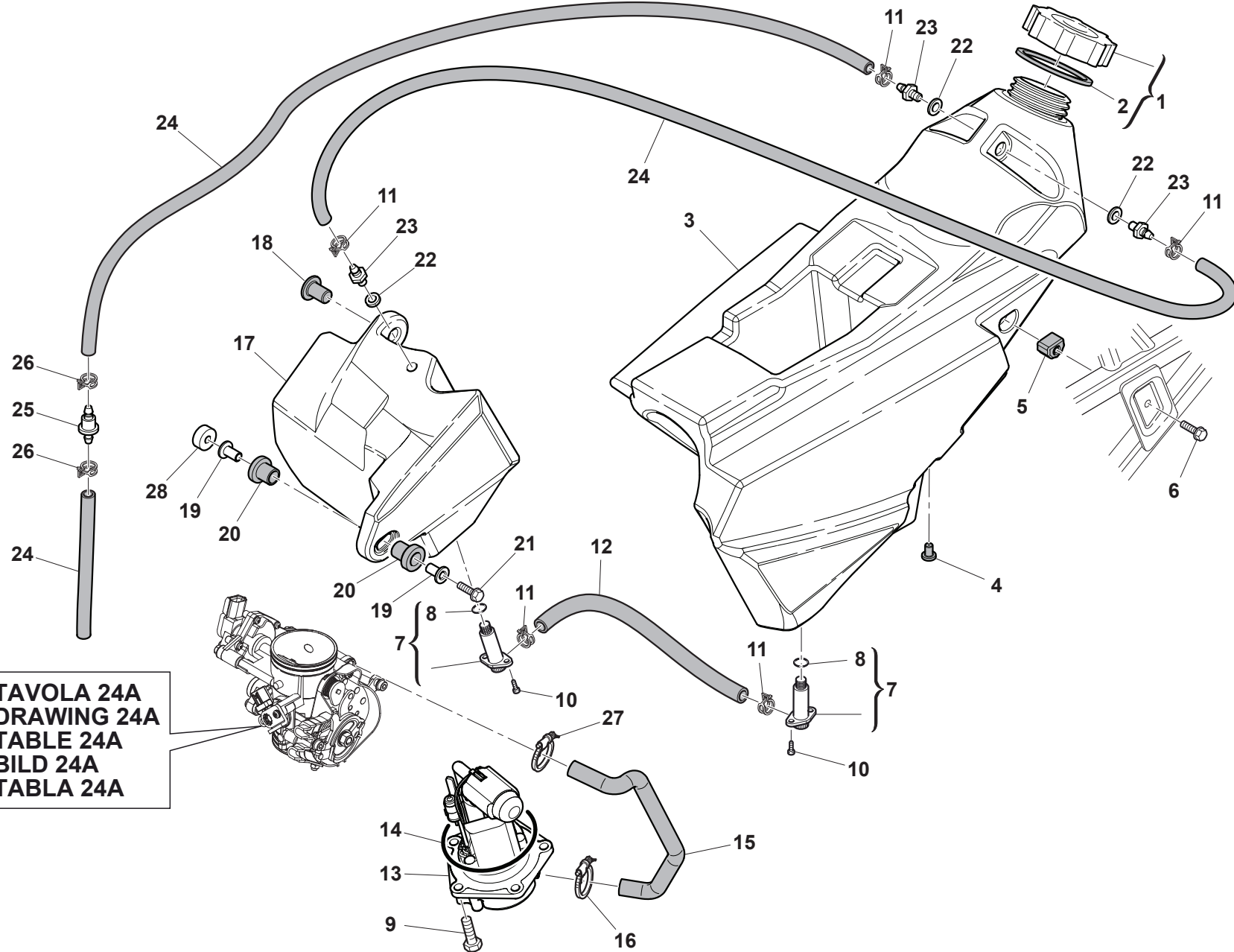
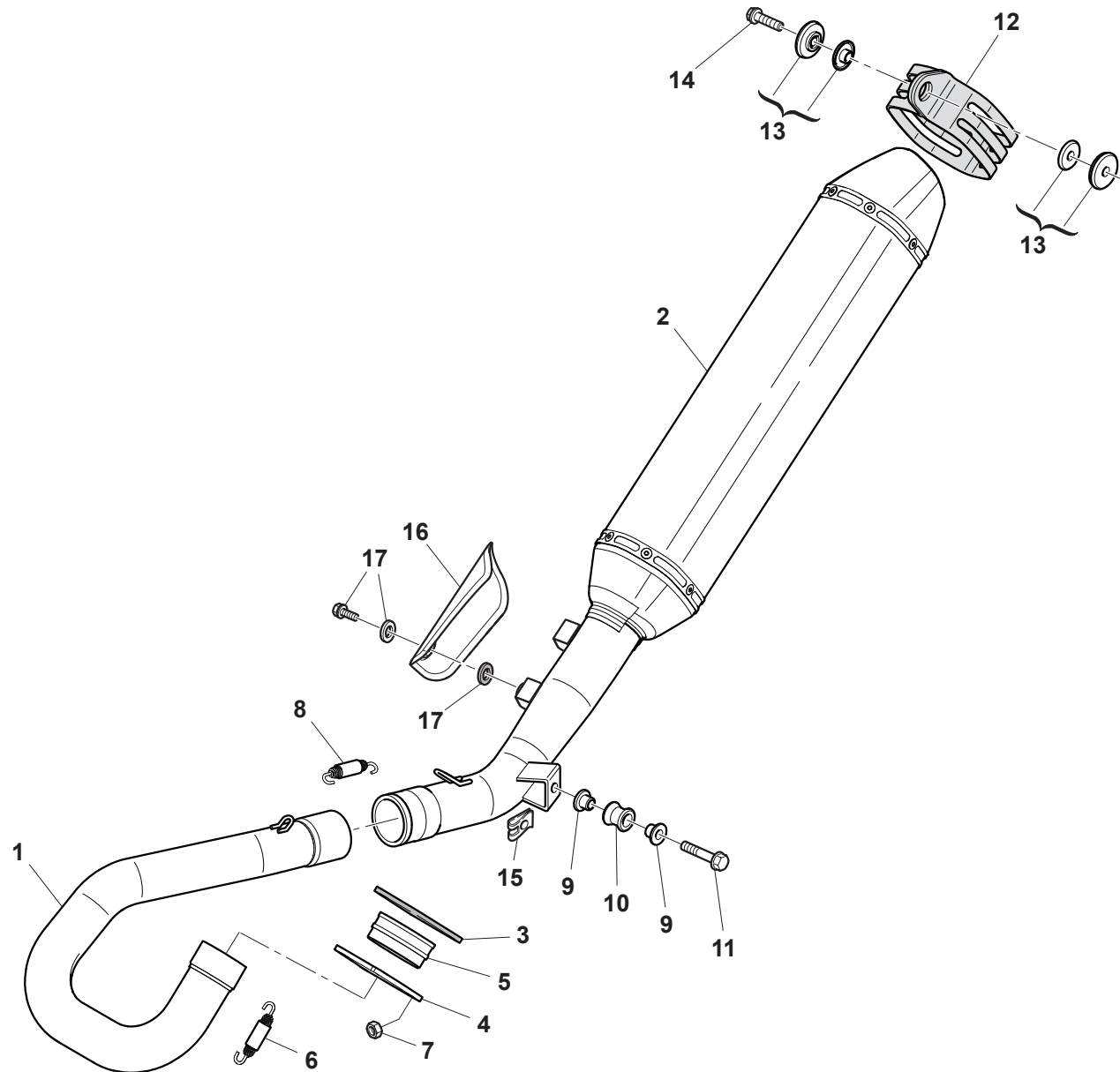

SCARICO - EXHAUST SYSTEM
TUYAU D'ÉCHAPPEMENT - AUSPUFFROHR
TUBO DE ESCAPE
TAVOLA - DRAWING
TABLE - BILD - TABLA

34

Note Notes Marke Notas	Pos. No. N. Index Pos.	N. Cod. Code No. Nr. Code Code Nr N. Cod.	Q.tà Q.ty Q.te M.ge C.ad	DENOMINAZIONE	NAME	DESIGNATION	BESHREIBUNG	DENOMINACION	Validità Validity Validité Gültig Validez
	1	8000H3186	1	COLLETTORE SCARICO	EXHAUST MANIFOLD	COLLECTEUR ECHAPPEMENT	AUSPUFFKRUEMMER	TUBERIA ESCAPE	
	2	8000H3187	1	SILENZIATORE	SILENCER, EXHAUST	SILENCIEUX	SCHALLDAEMPFER	SILENCIADOR	
	3	8000H5995	1	GUARNIZIONE SCARICO	GASKET, EXHAUST PIPE	JOINT TUYAU ECHAPPEMENT	DICHTUNG, AUSPUFFROHR	JUNTA TUBERIA ESCAPE	
	4	8000H5992	1	FLANGIA SCARICO	HOLDER-EXHAUST PIPE	BRIDE ECHAPPEMENT	FLANSCH AUSPUFFROHR	BRIDA TUBERIA ESCAPE	
	5	8000H5994	1	MANICOTTO	SLEEVE	MANCHON	MUFFE	MANGUERA	
	6	8000H5393	2	MOLLA SCARICO	SPRING, EXHAUST PIPE	RESSORT ANCRAGE TUYAU ECHAPPEMENT	FEDER AUSPUFFROHRBEFESTIGUNG	MUELLE ANCLAJE TUBERIA ESCAPE	
	7	Y00043928	2	DADO AUTOBLOCCANTE M8X1,25 H8 CH12	NUT, SELF LOCKING M8X1.25	ECROU AUTOBLOQUANT M8X1,25	SELBSTSPERRENDE MUTTER M8X1,25	TUERCA AUTOBLOQUEANTE M8X1,25	
	8	8000H5993	1	MOLLA SCARICO	SPRING, EXHAUST PIPE	RESSORT ANCRAGE TUYAU ECHAPPEMENT	FEDER AUSPUFFROHRBEFESTIGUNG	MUELLE ANCLAJE TUBERIA ESCAPE	
	9	8000H2975	2	BOCCOLA 12X8.5X12 MM	BUSH 12X8.5X12 MM	DOUILLE 12X8,5X12 MM	BUCHSE 12X8,5X12 MM	BUJE 12X8,5X12 MM	
	10	8000H0064	1	SILENTBLOCK	DAMPER	SILENTBLOC	SCHWINGUNGSDAEMPFER	CASQUILLO ELASTICO	
	11	ZK0069056	1	VITE TFE M8X1,25X35 CH12	SCREW TFE M8X1.25X35 CH12	VIS TFE M8X1,25X35 CH12	SCHRAUBE TFE M8X1,25X35 CH12	TORNILLO TFE M8X1,25X35 CH12	
	12	8000H5990	1	FASCETTA SILENZIATORE	BAND, SILENCER	COLLIER SILENCIEUX	FIXIERSCHELLE SCHALLDAEMPFER	ABRAZADERA SILENCIADOR	
	13	8000H5991	1	GRUPPO FISSAGGIO SILENZIATORE	MOUNTING KIT	KIT DE MONTAGE	BEFESTIGUNGSSATZ	KIT DE MONTAJE	
	14	ZC0069056	1	VITE TEF M8X1,25X30 CH12	SCREW TEF M8X1.25X30 CH12	VIS TEF M8X1,25X30 CH12	SCHRAUBE TEF M8X1,25X30 CH12	TORNILLO TEF M8X1,25X30 CH12	
	15	8000H5996	1	DADO ELASTICO	NUT, SPRING	ECROU ELASTIQUE	FEDERMUTTER	TUERCA ELASTICA	
	16	8000H5396	1	PROTEZIONE MARMITTA	COVER, MUFFLER	PROTECTEUR ECHAPPEMENT	SCHUTZ, AUSPUFF	PROTECTOR ESCAPE	
	17	8000H5395	1	KIT FISSAGGIO PROTEZIONE MARMITTA	FIXING SET, MUFFLER PROTECTOR	JEU FIXATION PROTECTION SILENCIEUX	BAUSATZ AUSPUFFSCHUTZ	KIT FIJACION PROTECCION ESCAPE	

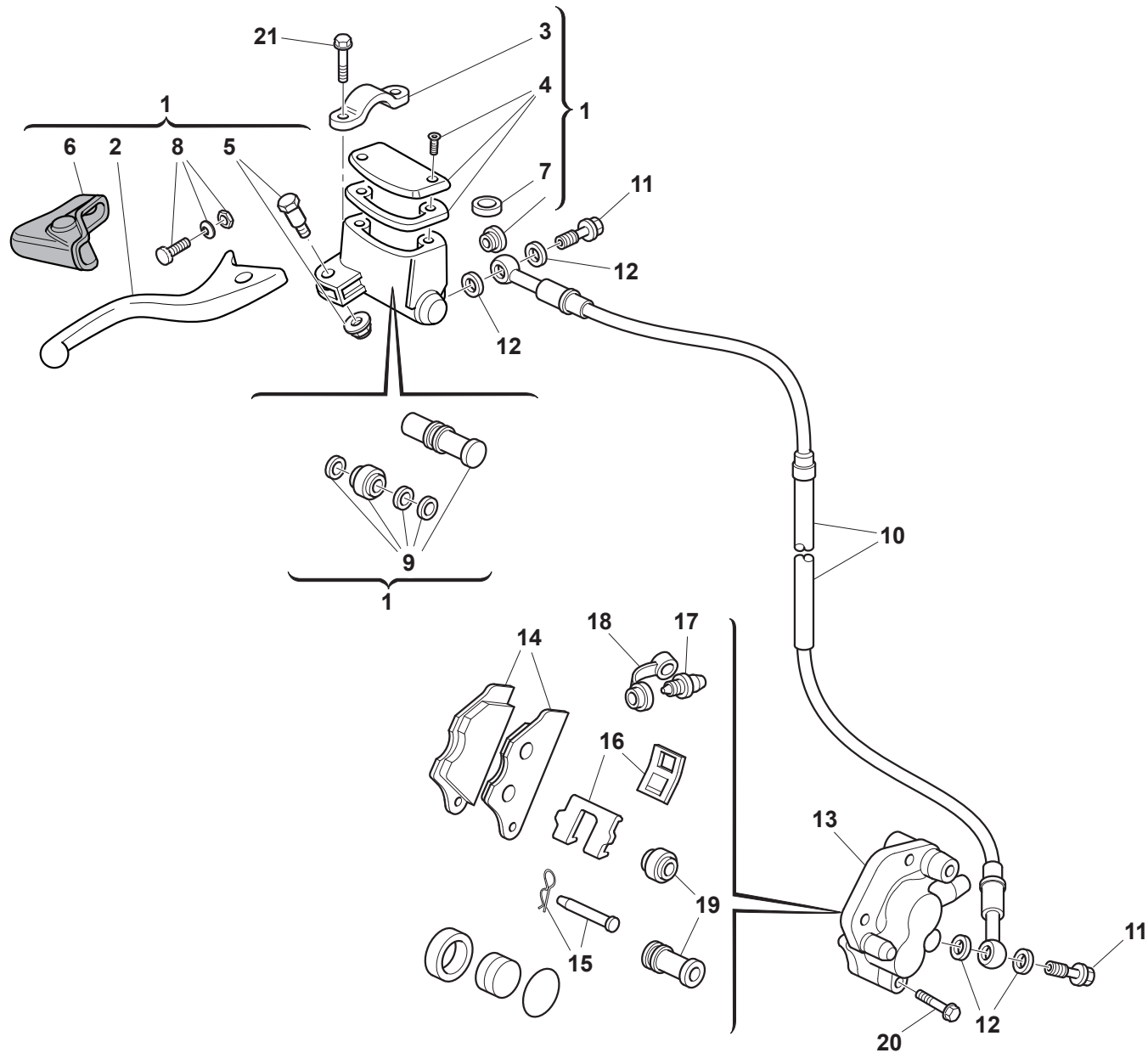

FRENO IDRAULICO ANTERIORE - FRONT HYDRAULIC BRAKE
FREIN HYDRAULIQUE AVANT - VORDERBREMSE
FRENO HIDRAULICO DELANTERO

TAVOLA - DRAWING
TABLE - BILD - TABLA

35

Note Notes Marke Notas	Pos. No. Index Pos.	N. Cod. Code No. Nr. Code Code Nr N. Cod.	Q.tà Q.ty Q.te M.ge C.ad	DENOMINAZIONE	NAME	DESIGNATION	BESHREIBUNG	DENOMINACION	Validità Validity Validité Gültig Validez
	1	8000A9347	1	POMPA FRENO ANTERIORE	CYLINDER, FRONT MASTER	MAITRE CYLINDRE FREIN AVANT	HAUPTZYLINDER, VORNE	BOMBA FRENO DELANTERO	
	2	8000A9351	1	LEVA FRENO ANTERIORE	LEVER, FRONT BRAKE	LEVIER FREIN AVANT	BREMSHEBEL VORNE	PALANCA FRENO DELANTERO	
	3	8000A4565	1	CAVALLOTTO POMPA FRENO	BRACKET, MASTER CYLINDER	BRIDE MAITRE CYLINDRE	KONSOLE, HAUPTBREMSZYLINDER	BRIDA BOMBA FRENO	
	4	800094126	1	COPERCHIO VASCHETTA LIQUIDO FRENI	COVER MASTER CYLINDER	COUVERCLE RESERVOIR LIQUIDE FREIN	VERSCHLUSS BREMSFLUESSIGKEITANK	TAPON DEPOSITO LIQUIDO FRENOS	
	5	800094127	1	PERNO LEVA FRENO	BOLT, HANDLE LEVER PIVOT	PIVOT LEVIER FREIN	HEBELSCHRAUBE KPL.	PERNO PALANCA FRENO	
	6	800094128	1	SOFFIETTO POMPA FRENO	DUST COVER	SOUFFLET EN CAOUTCHOUC	GUMMIBALG	FUELLE GOMA	
	7	800079099	1	ANTIEMULSIONANTE	ANTIEMULSION	ANTIEMULSION	EMULSIONWIDRIGER	ANTIEMULSION	
	8	8000A9349	1	VITE REGISTRO LEVA	ADJUSTING SCREW	VIS REGLAGE	EINSTELLSCHRAUBE	TORNILLO REGULACION	
	9	8000A9350	1	PISTONCINO POMPA FRENO	CYLINDER KIT, MASTER	PISTON MAITRE CYLINDRE	KOLBEN, BREMSEPUMPE	PISTON BOMBA FRENO	
	10	8A0093036	1	TUBO FRENO ANTERIORE	HOSE, FRONT BRAKE	TUYAU FREIN AVANT	BREMSSCHLAUCH VORNE	MANGUERA FRENO DELANTERO	
	11	U00057155	2	VITE RACCORDO TUBO M10X1,00X19	BOLT, BRAKE HOSE M10X1.00X19	VIS FIXATION TUYAU M10X1,00X19	FIXIERSCHRAUBE BREMSSCHLAUCH M10X1,00X19	TORNILLO MANGUERA ACEITE M10X1X19	
	12	800021480	2	RONDELLA 14X10,2X1 MM	WASHER 14X10.2X1 MM	RONDELLE 14X10,2X1 MM	SCHEIBE 14X10,2X1 MM	ARANDELA 14X10,2X1 MM	
	13	8000H3082	1	PINZA FRENO ANTERIORE	CALIPER, FRONT BRAKE	ETRIER FREIN AVANT	BREMSSATTEL, VORNE	PINZA FRENO DELANTERO	
	14	8000H0770	1	COPPIA PASTIGLIE FRENO ANTERIORE	PADS SET, FRONT BRAKE	JEU PLAQUETTES FREIN AVANT	VORNEBREMSBELAEGESATZ	JUEGO PASTILLAS FRENO DELANTERO	
	15	800079073	1	GRUPPO REVISIONE PERNI PASTIGLIE	PAD PINS OVERHAUL SET	GROUPE REVISION PIVOTS PLAQUETTE	BREMBELAEGEN EBERHOLUNGSGRUPPE	GRUPO REVISION PERNO PASTILLAS FRENO	
	16	8540228	1	MOLLETTE PASTIGLIE FRENO	SUPPORT, PAD	RESSORT PLAQUETTE FREIN	FEDER, BREMSESHEIBE	MUELLE PASTILLAS	
	17	8000A2041	1	VITE SPURGO	SCREW, BLEED	VIS VIDANGE	SCHRAUBE, ABLASS	TORNILLO PURGA	
	18	8000A2042	1	CAPPUCCIO VITE SPURGO	CAP, BLEEDER SCREW	CAPUCHON VIS RENIFLARD	ENTLUEFTUNGSKAPPE	CAPUCHON TORNILLO PURGA PINZA	
	19	800079066	2	SERIE SILENTBLOCK PINZA FRENO	CAPS OVERHAUL SET	GROUPE REVISION CAPOUCHONS	GUMMIUBERARBEITUNGSATZ	GRUPO REVISION GORRO	
	20	ZA0062733	2	VITE TE M8X1,25X40	SCREW TE M8X1.25X40	VIS TE M8X1,25X40	SCHRAUBE TE M8X1,25X40	TORNILLO TE M8X1,25X40	
	21	Z00062729	2	VITE TEF M6X1X25 CH8	SCREW TEF M6X1X25 CH8	VIS TEF M6X1X25 CH8	SCHRAUBE TEF M6X1X25 CH8	TORNILLO TEF M6X1X25 CH8	

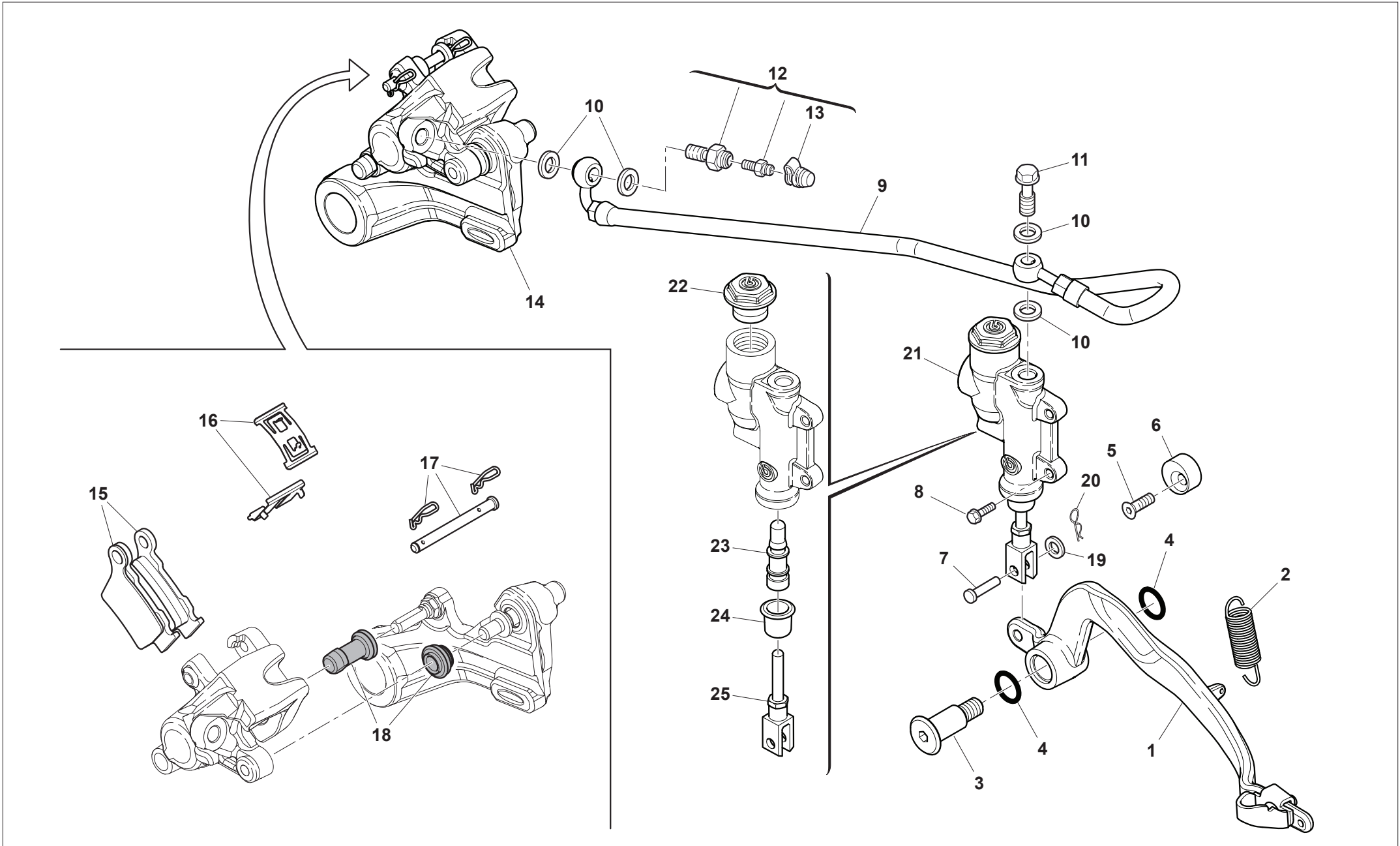

FRENO IDRAULICO POSTERIORE - REAR HYDRAULIC BRAKE
FREIN HYDRAULIQUE ARRIERE - HINTERBREMSE
FRENO HIDRAULICO TRASERO

TAVOLA - DRAWING
TABLE - BILD - TABLA

36

Note Notes Marke Notas	Pos. No. Index Pos.	N. Cod. Code No. Nr. Code Code Nr N. Cod.	Q.tà Q.ty Q.te M.ge C.ad	DENOMINAZIONE	NAME	DESIGNATION	BESHREIBUNG	DENOMINACION	Validità Validity Validité Gültig Validez
	1	8000H3084	1	PEDALE FRENO	PEDAL, BRAKE	PEDALE FREIN	FUSSBREMSPEDAL	PEDAL FRENO	
	2	8A0055903	1	MOLLA PEDALE FRENO	SPRING, BRAKE PEDAL	RESSORT PEDALE FREIN	FEDER, BREMSPEDAL	MUELLE PEDAL FRENO	
	3	Y00055902	1	VITE TPEI M10X1,25X16	SCREW TPEI M10X1.25X16	VIS TPEI M10X1,25X16	SCHRAUBE TPEI M10X1,25X16	TORNILLO TPEI M10X1,25X16	
	4	800022551	2	ANELLO O-RING 2056 14X1,78	O-RING 2056 14X1.78	JOINT TORIQUE 2056 14X1,78	O-RING 2056 14X1,78	JUNTA TORICA 2056 14X1,78	
	5	Y00055241	1	VITE TSEI M6X1X20 CH5	SCREW TSEI M6X1X20 CH5	VIS TSEI M6X1X20 CH5	SCHRAUBE TSEI M6X1X20 CH5	TORNILLO TSEI M6X1X20 CH5	
	6	8A0069125	1	ECCENTRICO PEDALE FRENO	ECCENTRIC, ADJUSTMENT BRAKE PEDAL	EXCENTRIQUE REGLAGE PEDAL FREIN	REGULIEREXZENTIKER BREMSE PEDAL	EXCENTRICO REGULACION PEDAL FRENO	
	7	8000H4038	1	PERNO	PIN	PIVOT	BOLZEN	PERNO	
	8	Z00062726	2	VITE TEF M6X1X14 CH8	SCREW TEF M6X1X14 CH8	VIS TEF M6X1X14 CH8	SCHRAUBE TEF M6X1X14 CH8	TORNILLO TEF M6X1X14 CH8	
	9	8000H3092	1	TUBO FRENO POSTERIORE	HOSE, REAR BRAKE	TUYAU FREIN ARRIERE	BREMSSCHLAUCH HINTEN	MANGUERA FRENO TRASERO	
	10	800090485	4	RONDELLA 14X10,2X1,5	WASHER 14X10.2X1.5	RONDELLE 14X10,2X1,5	SCHEIBE 14X10,2X1,5	ARANDELA 14X10,2X1,5	
	11	U00057155	1	VITE RACCORDO TUBO M10X1,00X19	BOLT, BRAKE HOSE M10X1.00X19	VIS FIXATION TUYAU M10X1,00X19	FIXIERSCHRAUBE BREMSSCHLAUCH M10X1,00X19	TORNILLO MANGUERA ACEITE M10X1X19	
	12	8000A3975	1	VITE RACCORDO TUBO OLIO	BOLT, OIL PIPE	VIS FIXATION TUYAU HUILE	FIXIERSCHRAUBE OELSCHLAUCH	TORNILLO FIJACION TUBO ACEITE	
	13	800053259	1	CAPPUCCIO VITE SPURGO	CAP, BLEEDER SCREW	CAPUCHON VIS RENIFLARD	ENTLUEFTUNGSKAPPE	CAPUCHON TORNILLO PURGA PINZA	
	14	8000A4291	1	PINZA FRENO POSTERIORE	CALIPER, REAR BRAKE	ETRIER FREIN ARRIERE	HINTEN BREMSSATTEL	PINZA FRENO TRASERA	
	15	8000A2790	1	COPPIA PASTIGLIE FRENO POSTERIORE	PADS SET, REAR BRAKE	JEU PLAQUETTES FREIN ARRIERE	HINTERBREMSBELAEGESATZ	JUEGO PASTILLAS FRENO TRASERO	
	16	8000A2792	1	MOLLETTE PASTIGLIE FRENO	SUPPORT, PAD	RESSORT PLAQUETTE FREIN	FEDER, BREMSESHEIBE	MUELLE PASTILLAS	
	17	8000A2791	1	GRUPPO REVISIONE PERNI PASTIGLIE	PAD PINS OVERHAUL SET	GROUPE REVISION PIVOTS PLAQUETTE	BREMSELAEGEN EBERHOLUNGSGRUPPE	GRUPO REVISION PERNO PASTILLAS FRENO	
	18	800079066	1	SERIE SILENTBLOCK PINZA FRENO	CAPS OVERHAUL SET	GROUPE REVISION CAPOUCHONS	GUMMIUBERARBEITUNGSZ	GRUPO REVISION GORRO	
	19	62ND15504	1	RONDELLA 12X6,4X1	WASHER 12X6.4X1	RONDELLE 12X6,4X1	SCHEIBE 12X6,4X1	ARANDELA 12X6,4X1	
	20	64ND20068	1	COPIGLIA 1,8X18	PIN, COTTER 1.8X18	GOUPILLE FENDUE 1,8X18	SPLINT 1,8X18	GRUPILLA 1,8X18	
	21	8000H3625	1	POMPA FRENO POSTERIORE	CYLINDER, REAR MASTER	MAITRE CYLINDRE FREIN ARRIERE	HAUPTZYLINDER, HINTEN	BOMBA FRENO TRASERO	
	22	8000A9447	1	TAPPO POMPA FRENO POSTERIORE	PLUG CYLINDER, REAR MASTER	BOUCHON MAITRE CYLINDRE FREIN ARRIERE	VERSCHLUSS HAUPTZYLINDER, HINTEN	TAPON BOMBA FRENO TRASERO	
	23	8000H6037	1	PISTONCINO POMPA FRENO	CYLINDER KIT, MASTER	PISTON MAITRE CYLINDRE	KOLBEN, BREMSEPUMPE	PISTON BOMBA FRENO	
	24	8000H6036	1	CUFFIA	BOOT	COIFFE	HAUBE	GORRO	
	25	8000H6038	1	ASTINA POMPA FRENO	ROD, BRAKE	TIGE MAITRE CYLINDRE	HAUPTZYLINDERSTANGE	VARILLA BOMBA FRENO	

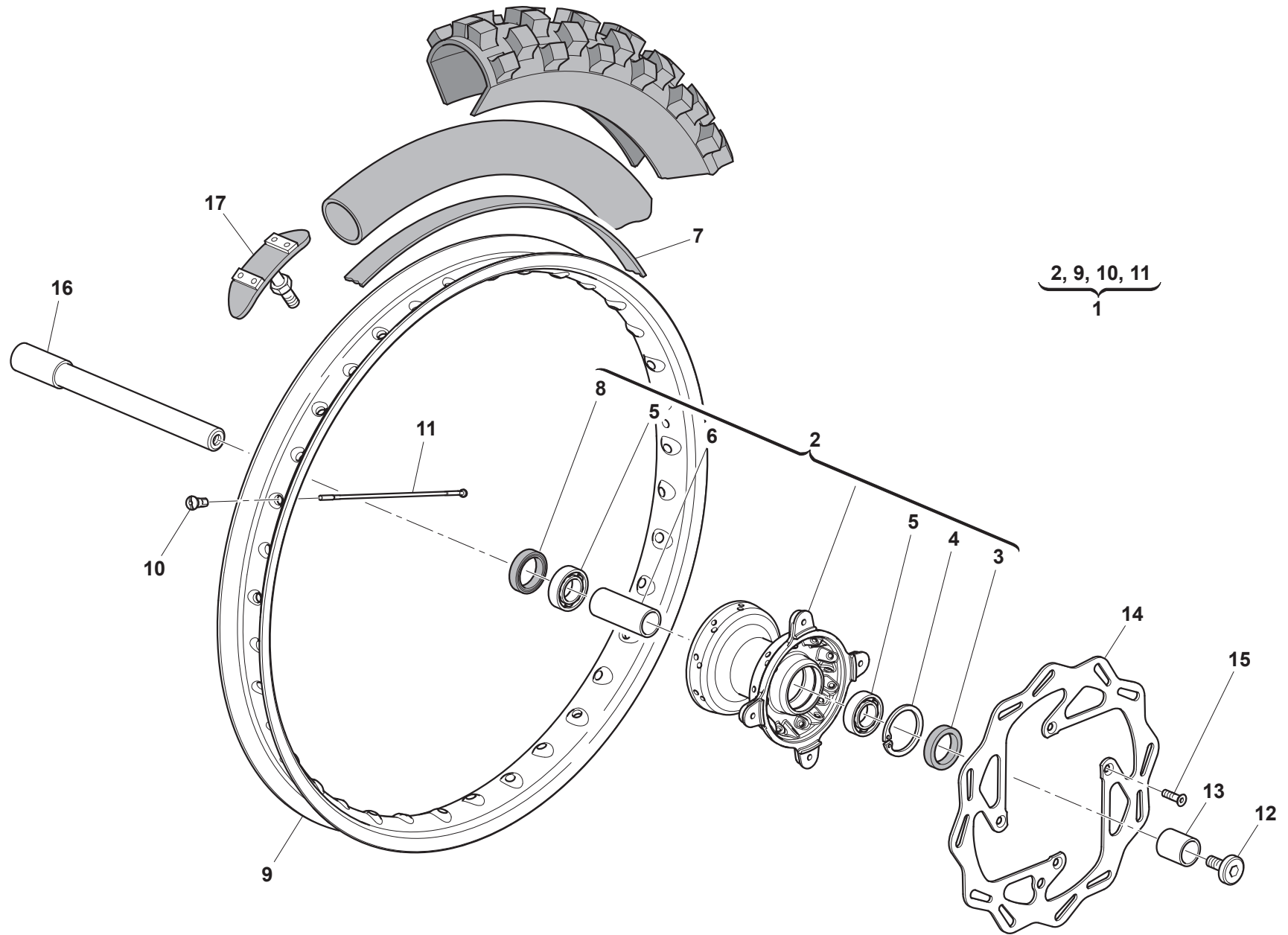

RUOTA ANTERIORE - FRONT WHEEL
ROUE AVANT - VORTERRAD
RUEDA DELANTERA
TAVOLA - DRAWING
TABLE - BILD - TABLA**37**

Note Notes Marke Notas	Pos. No. N. Index Pos.	N. Cod. Code No. Nr. Code Code Nr N. Cod.	Q.tà Q.ty Q.te M.ge C.ad	DENOMINAZIONE	NAME	DESIGNATION	BESHREIBUNG	DENOMINACION	Validità Validity Validité Gültig Validez
	1	8A00H1360	1	RUOTA ANTERIORE	WHEEL, FRONT	ROUE AVANT	VORDERRAD	RUEDA DELANTERA	
	2	8000H1363	1	MOZZO RUOTA ANTERIORE	HUB, FRONT WHEEL	MOYEU ROUE AVANT	RADNABE, VORNE	CUBO RUEDA DELANTERA	
	3	800022966	1	PARAPOLVERE 32X42X7	SEAL, DUST 32X42X7	PARE POUSSIÈRE 32X42X7	STAUBDECKEL 32X42X7	GUARDAPOLVO 32X42X7	
	4	66N021270	1	ANELLO SEEGER INTERNO 42MM DIN472	CIRCLIP 42MM DIN472	CIRCLIP 42MM DIN472	SEEGERRING 42MM DIN472	ANILLO SEEGER 42MM DIN472	
	5	800084938	2	CUSCINETTO A SFERE 25X42X9	BEARING, BALL 25X42X9	ROULEMENT A BILLES 25X42X9	KUGELLAGER 25X42X9	COJINETE DE BOLAS 25X42X9	
	6	8000H6186	1	DISTANZIALE INTERNO CUSCINETTI	SPACER, HUB BEARING	ENTRETOISE INTERNE ROULEMENT	KUGELLAGER INNEREABSTANDHALTER	DISTANCIADOR INTERIOR COJINETE	
	7	800013346	1	FASCIA SALVACAMERA	PROTECTOR, INNER TUBE	FOND JANTE	FELGENBAND	PROTECTOR CAMARA	
	8	8000H6187	1	PARAPOLVERE 42X28X7	SEAL, DUST 42X28X7	PARE POUSSIÈRE 42X28X7	STAUBDECKEL 42X28X7	GUARDAPOLVO 42X28X7	
	9	8A00H1361	1	CERCHIO RUOTA ANTERIORE	RIM, FRONT WHEEL	JANTE ROUE AVANT	FELGE, VORDERRAD	LLANTA RUEDA DELANTERA	
	10	8000A6208	36	NIPPLO RAGGIO	NIPPLE, SPOKE	ECROU RAYON	NIPPEL, SPEICHE	TUERCA RADIO	
	11	8000H1362	36	RAGGIO RUOTA ANTERIORE	SPOKE, FRONT WHEEL	RAYON ROUE AVANT	SPEICHE, VORDERRAD	RADIO RUEDA DELANTERA	
	12	800096933	1	VITE M20	SCREW M20	VIS M20	SCHRAUBE M20	TORNILLO M20	
	13	8A0096930	2	DISTANZIALE	SPACER	ENTRETOISE	ABSTANDHALTER	DISTANCIADOR	
	14	8000H0192	1	DISCO FRENO ANTERIORE	DISC, FRONT BRAKE	DISQUE FREIN AVANT	BREMSSCHEIBE, VORNE	DISCO FRENO DELANTERO	
	15	YA0055241	4	VITE TCEI M6X1X14 CH5	SCREW TCEI M6X1X14 CH5	VIS TCEI M6X1X14 CH5	SCHRAUBE TCEI M6X1X14 CH5	TORNILLO TCEI M6X1X14 CH5	
	16	8000H1547	1	PERNO RUOTA ANTERIORE	AXLE, FRONT WHEEL	AXE ROUE AVANT	VORDERRADACHSE	EJE RUEDA DELANTERA	
	17	800049036	1	FERMACOPERTONE	TIRE BLEND CLAMP	PLAQUE ARRET PNEU	REIFEN FIXIERPLATTE	PLACA SUJECION NEUMATICO	

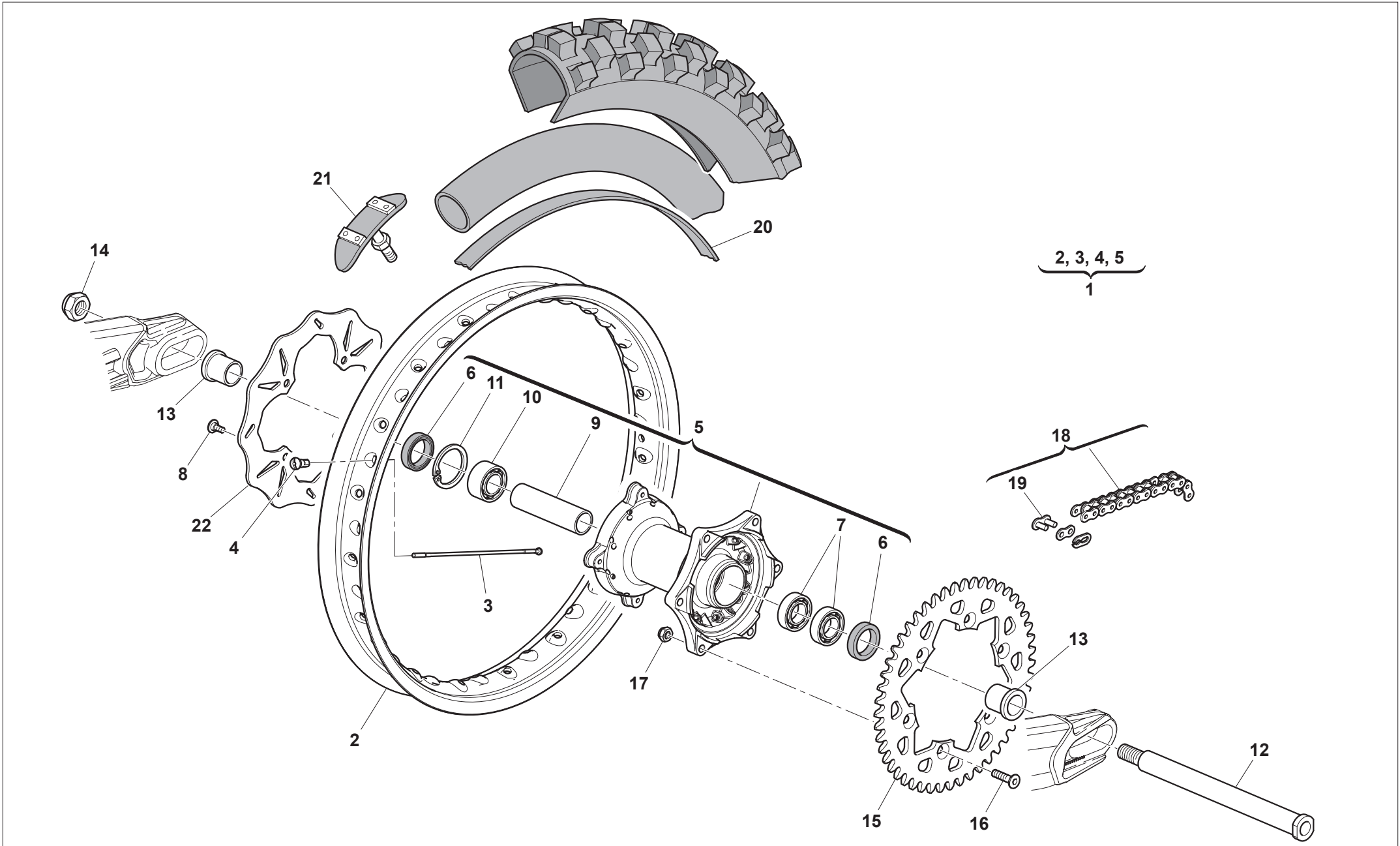

RUOTA POSTERIORE - REAR WHEEL
ROUE ARRIERE - HINTERRAD
RUEDA TRASERA
TAVOLA - DRAWING
TABLE - BILD - TABLA

38

Note Notes Marke Notas	Pos. No. Index Pos.	N. Cod. Code No. Nr. Code Code Nr N. Cod.	Q.tà Q.ty Q.te M.ge C.ad	DENOMINAZIONE	NAME	DESIGNATION	BESHREIBUNG	DENOMINACION	Validità Validity Validité Gültig Validez
	1	8A00H1364	1	RUOTA POSTERIORE	WHEEL, REAR	ROUE ARRIERE	HINTERRAD	RUEDA TRASERA	
	2	8A00H1365	1	CERCHIO RUOTA POSTERIORE	RIM, REAR WHEEL	JANTE ROUE ARRIERE	FELGE, HINTENRAD	LLANTA RUEDA TRASERA	
	3	8000H1366	18	RAGGIO RUOTA POSTERIORE LATO DISCO	SPOKE, REAR WHEEL, DISC SIDE	RAYON ROUE ARRIERE COTE DISQUE	HINTERRADSPEICHE SCHEIBE SEITE	RADIO RUEDA TRASERA LATO DISCO	
	3	8000H1367	18	RAGGIO RUOTA POSTERIORE LATO CORONA	SPOKE, REAR WHEEL, SPROCKET SIDE	RAYON ROUE ARRIERE COTE COURONNE	HINTERRADSPEICHE ZAHNKETTENRAD SEITE	RADIO RUEDA TRASERA LATO CORONA	
	4	8000A6209	36	NIPPLO RAGGIO ALPINA	NIPPLE, SPOKE ALPINA	ECROU RAYON ALPINA	NIPPEL, SPEICHE ALPINA	TUERCA RADIO ALPINA	
	5	8A00H1368	1	MOZZO RUOTA POSTERIORE	HUB, REAR WHEEL	MOYEU ROUE ARRIERE	RADNABE, HINTEN	CUBO RUEDA TRASERA	
	6	800089572	2	PARAOLIO 32X47X7	OIL SEAL 32X47X7	BAGUE D'ETANCHEITE 32X47X7	WELLENDICHTRING 32X47X7	RETEN DE ACEITE 32X47X7	
	7	8A0026846	2	CUSCINETTO A SFERE 6005	BEARING, BALL 6005	ROULEMENT A BILLES 6005	KUGELLAGER 6005	COJINETE DE BOLAS 6005	
	8	800055878	4	VITE TPEI M6X1X11	SCREW TPEI M6X1.00X11	VIS TPEI M6X1.00X11	SCHRAUBE TPEI M6X1.00X11	TORNILLO TPEI M6X1.00X11	
	9	8000H6189	1	DISTANZIALE INTERNO CUSCINETTI	SPACER, HUB BEARING	ENTRETOISE INTERNE ROULEMENT	KUGELLAGER INNEREABSTANDHALTER	DISTANCIADOR INTERIOR COJINETE	
	10	8B0026846	1	CUSCINETTO A SFERE 25X47X16	BEARING, BALL 25X47X16	ROULEMENT A BILLES 25X47X16	KUGELLAGER 25X47X16	COJINETE DE BOLAS 25X47X16	
	11	66N021272	1	ANELLO ELASTICO 50,5 MM	CIRCLIP 50.5 MM	CIRCLIP 50,5 MM	SPRENGRING 50,5 MM	ANILLO ELASTICO 50,5 MM	
	12	8000H1548	1	PERNO RUOTA POSTERIORE	AXLE, REAR WHEEL	AXE ROUE ARRIERE	HINTERRADACHSE	EJE RUEDA TRASERA	
	13	800096938	2	DISTANZIALE ESTERNO	SPACER, OUTER	ENTRETOISE EXTERIEUR	ABSTANDHALTER, AUSSER	DISTANCIADOR EXTERIOR	
	14	Y00093072	1	DADO M20X1,5 CH27	NUT M20X1.5 CH27	ECROU M20X1,5 CH27	MUTTER M20X1,5 CH27	TUERCA M20X1,5 CH27	
	15	8H0096837	1	CORONA Z53	REAR SPROCKET T53	COURONNE D53	ZAHNKETTENRAD Z53	CORONA D53	
	16	8000H0158	6	VITE SPECIALE TSEI M8X1,25X28 CH6	SCREW, SPECIAL TSEI M8X1.25X28 CH6	VIS SPECIAL TSEI M8X1,25X28 CH6	SPEZIALSCHRAUBE TSEI M8X1,25X28 CH6	TORNILLO ESPECIAL TSEI M8X1,25X28 CH6	
	17	Y00043928	6	DADO AUTOBLOCCANTE M8X1,25 H8 CH12	NUT, SELF LOCKING M8X1.25	ECROU AUTOBLOQUANT M8X1,25	SELBSTSPERRENDE MUTTER M8X1,25	TUERCA AUTOBLOQUEANTE M8X1,25	
	18	8E0056768	1	CATENA	CHAIN	CHAINE	KETTE	CADENA	
	19	800056767	1	GIUNTO CATENA REGINA 135RX	CHAIN LINK REGINA 135RX	JOINT CHAINE REGINA 135RX	VERBINDUNG KETTE REGINA 135RX	RACORD CADENA REGINA 135RX	
	20	800010777	1	FASCIA SALVACAMERA	PROTECTOR, INNER TUBE	FOND JANTE	FELGENBAND	PROTECTOR CAMARA	
	21	800054073	1	FERMACOPERTONE	TIRE BLEND CLAMP	PLAQUE ARRET PNEU	REIFEN FIXIERPLATTE	PLACA SUJECION NEUMATICO	
	22	8000H4977	1	DISCO FRENO POSTERIORE	DISC REAR BRAKE	DISQUE FREIN ARRIERE	BREMSSCHEIBE, HINTEN	DISCO FRENO TRASERO	



TAVOLA 20
DRAWING 20
TABLE 20
BILD 20
TABLA 20

**GRUPPO CAVI, PARTI ELETTRICHE - MAIN WIRING HARNESS, ELECTRICAL PARTS -
CABLES PRINCIPAL, PARTIES ELECTRIQUES - KABEL, ELEKTRISCHE KOMPONENTE -
GRUPO PRINCIPAL CABLES, PARTES ELECTRICAS**

TAVOLA - DRAWING
TABLE - BILD - TABLA

39

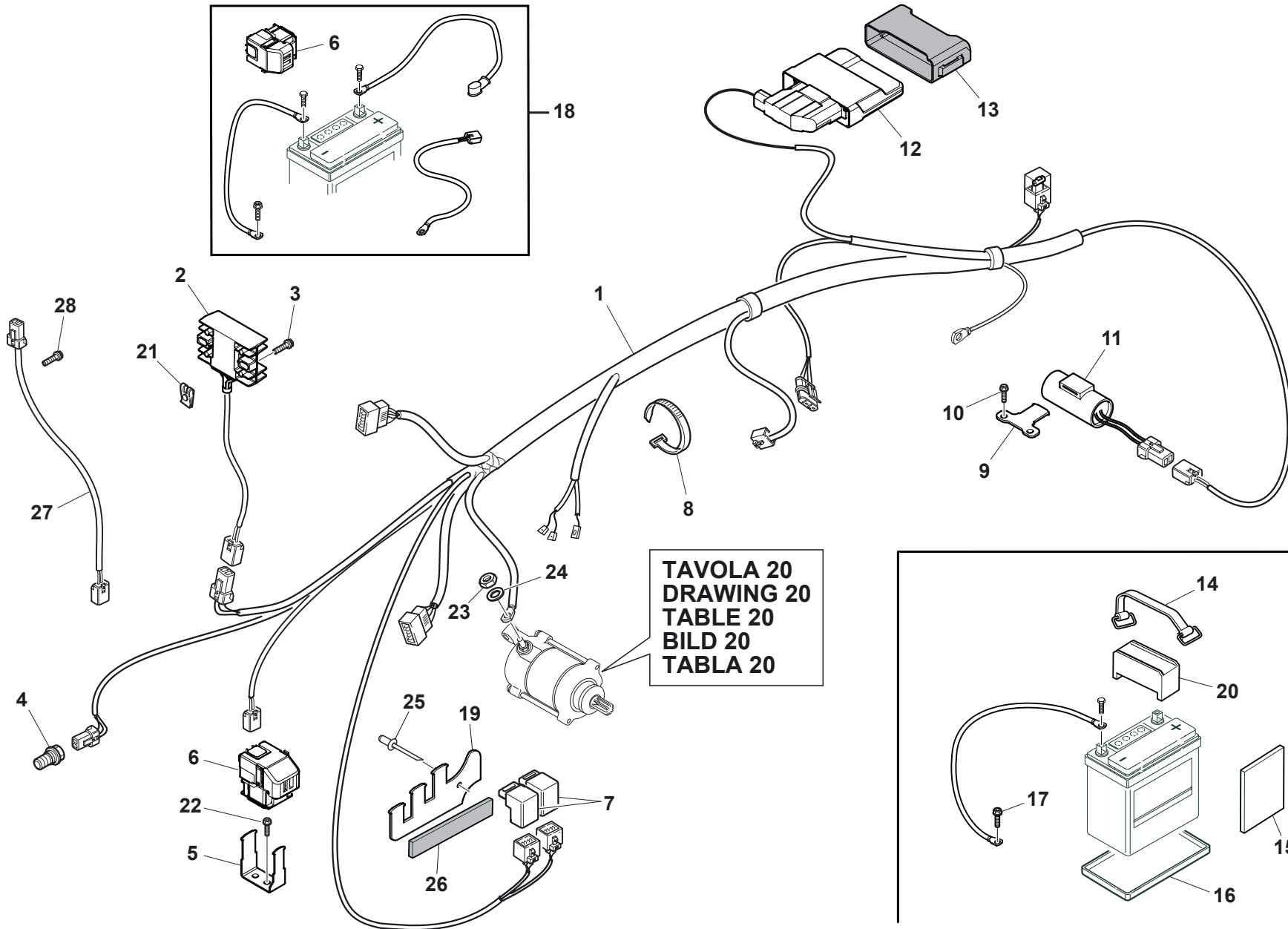
Note Notes Marke Notas	Pos. No. N. Index Pos.	N. Cod. Code No. Nr. Code Code Nr N. Cod.	Q.tà Q.ty Q.te M.ge C.ad	DENOMINAZIONE	NAME	DESIGNATION	BESHREIBUNG	DENOMINACION	Validità Validity Validité Gültig Validez
	1	8000H6691	1	IMPIANTO ELETTRICO	WIRING HARNESS	FAISCEAU CABLES PRINCIPAL	HAUPTVERKABELUNG	GRUPO CABLES PRINCIPAL	
	2	8000H5045	1	REGOLATORE DI TENSIONE	REGULATOR & RECTIFIER	REGULATEUR TENSION	SPANNUNGSREGLER	REGULADOR TENSION	
	3	ZPA067545	2	VITE TEF M6X1X22 CH8	SCREW TEF M6X1X22 CH8	VIS TEF M6X1X22 CH8	SCHRAUBE TEF M6X1X22 CH8	TORNILLO TEF M6X1X22 CH8	
	4	8000H3649	1	SENSORE TEMPERATURA ACQUA	SENSOR WATER TEMPERATURE	CAPTEUR TEMPERATURE EAU	WASSERTemperaturFUEHLER	SENSOR TEMPERATURA AGUA	
	5	8000H4507	1	SUPPORTO TELERUTTORE AVVIAMENTO	BRACKET, STARTER RELAY	SUPPORT RELAIS DEMARRAGE	HALTERUNG FERNSCHALTER	SOPORTE TELERUPTOR ARRANQUE	
	6	8000H3644	1	TELERUTTORE AVVIAMENTO	RELAY, STARTING MOTOR	RELAIS DEMARRAGE	STARTRELAIS	RELE ARRANQUE	
	7	8000A6749	2	RELE'	RELAY	RELAIS	RELAIS	RELE	
	8	800056444	3	FASCETTA 188 MM	CLAMP 188 MM	COLLIER 188 MM	SHELLE 188 MM	ABRAZADERA 188 MM	
	9	8000H3896	1	PIASTRINA	PLATE	PLAQUETTE	PLAETTCHEN	PLETINA	
	10	Z00062725	2	VITE TEF M6X1X10 CH8	SCREW TEF M6X1.00X10 CH8	VIS TEF M6X1.00X10 CH8	SCHRAUBE TEF M6X1.00X10 CH8	TORNILLO TEF M6X1.00X10 CH8	
	11	8000A0107	1	CONDENSATORE	CAPACITOR	CONDENSATEUR	KONDENSATOR	CONDENSADOR	
EUR	12	8BA0H3182	1	CENTRALINA	CONTROL UNIT	UNITE CONTROLE	STEUERGERAET	CENTRALITA CONTROL	
USA	12	8BB0H3182	1	CENTRALINA	CONTROL UNIT	UNITE CONTROLE	STEUERGERAET	CENTRALITA CONTROL	
	13	8000H3183	1	SUPPORTO ELASTICO CENTRALINA INIEZIONE	DAMPER, ENGINE CONTROL UNIT	COUSSIN UNITE CONTROLE INJECTION	HALTERKISSEN, EINSPRITZUNG ZENTRALANLAGE	COJIN SOPORTE CENTRAL INYECCION	
	14	8000H3651	1	ELASTICO BATTERIA	BAND BATTERY	ELASTIQUE BATTERIE	BAND, BATTERIE	ELASTICO BATERIA	
	15	8A0087072	4	TAMPONE ADESIVO	GROMMET ADHESIVE	CAOUTCHOUC ADHESIF	KLEBERGUMMI	GOMA ADHESIVA	
	16	8000H6014	1	CUSCINO BATTERIA	DAMPER, BATTERY	COUSSIN BATTERIE	BATTERIE KISSEN	COJIN BATERIA	
	17	Z00067997	1	VITE TEF M5X0,8X12 CH8	SCREW TEF M5X0.8X12 CH8	VIS TEF M5X0.8X12 CH8	SCHRAUBE TEF M5X0.8X12 CH8	TORNILLO TEF M5X0.8X12 CH8	
	18	8000H7079	1	GRUPPO CAVI BATTERIA	BATTERY CABLE HARNESS	FAISCEAU CABLES BATTERIE	KABELBAUM, BATTERIE	GRUPO CABLES BATERIA	
	19	8000H6597	1	PIASTRINA	PLATE	PLAQUETTE	PLAETTCHEN	PLETINA	
	20	8000H4826	1	STAFFA FISSABATTERIA	BRACKET	EQUERRE	KONSOLE	SOPORTE	
	21	U00046893	2	DADO ELASTICO M6X1	CLIP NUT M6X1	JONC M6X1	KLEMME M6X1	PRESILLA M6X1	
	22	ZD0067997	2	VITE TEF M5X0,8X8 CH8	SCREW TEF M5X0.8X8 CH8	VIS TEF M5X0.8X8 CH8	SCHRAUBE TEF M5X0.8X8 CH8	TORNILLO TEF M5X0.8X8 CH8	
	23	Z00061313	1	DADO M6X1 H6 CH10	NUT M6X1 H6 CH10	ECROU M6X1 H6 CH10	MUTTER M6X1 H6 CH10	TUERCA M6X1 H6 CH10	
	24	Z00036137	1	RONDELLA 11X5,5X1,5 MM	WASHER 11X5.5X1.5 MM	RONDELLE 11X5,5X1,5 MM	SCHEIBE 11X5,5X1,5 MM	ARANDELA 11X5,5X1,5 MM	
	25	8000H7655	1	RIVETTO 3,2X8	RIVET 3.2X8	RIVET 3,2X8	NIETE 3,2X8	REMACHE 3,2X8	
	26	800086004	1	TAMPONE ADESIVO	GROMMET ADHESIVE	CAOUTCHOUC ADHESIF	KLEBERGUMMI	GOMA ADHESIVA	
	27	8000H7395	1	CAVO SENSORE FOLLE	CABLE, NEUTRAL SWITCH	CABLE CONTACTEUR POINT-MORT	KABEL, LEERLEERLAUFSCHALTER	CABLE INTERRUPTOR NEUTRAL	
	28	ZH0067545	1	VITE TEF M6X1X12 CH8	SCREW TEF M6X1X12 CH8	VIS TEF M6X1X12 CH8	SCHRAUBE TEF M6X1X12 CH8	TORNILLO TEF M6X1X12 CH8	

