

# Husqvarna

## SMS4-TE 125/2011

Ed. 03-2014



## INFORMAZIONI GENERALI

Il presente catalogo serve per richiedere con esattezza le parti di ricambio  
Nelle ordinazioni indicare:

- 1) il numero di codice dei particolari seguito dalla descrizione;
  - 2) il colore per i pezzi verniciati o comunque colorati;
  - 3) il numero di matricola del motociclo, stampigliato sul canotto di sterzo.
- Le indicazioni destra e sinistra si riferiscono ai lati del veicolo rispetto al senso di marcia;

## GENERAL INFORMATION

The present spare parts list enables one to order exactly the right spare parts.  
When ordering specify:

- 1) the part's code number followed by its description;
  - 2) indicate colour for painted or coloured parts;
  - 3) the motorcycle's serial number, stamped on the steering head.
- References to right and left apply to the vehicle in terms of its direction of movement.

## INFORMATIONS GENERALES

Ca catalogue permet de commander correctement les pièces de rechange.  
Les commandes doivent être passées en indiquant:

- 1) le numéro de code des pièces détachées suivi de leur description;
  - 2) le couleur des pièces peintes ou colorés;
  - 3) le matricule de la moto, estampillé sur la tige du guidon.
- Droite et gauche sont les côtés du véhicule par rapport au sens de la marche.

## ALLGEMEINE HINWEISE

Dieser Ersatzteilkatalog dient zur genauen Angabe der Teile bei  
Ersatzteilbestellungen.

- Bei Ersatzbestellung ist folgendes anzugeben:
- 1) Die Bestellnummer der Ersatzteile mit der entsprechenden Beschreibung;
  - 2) Farbe für lackierte und farbige Teile angeben;
  - 3) Die Sseriennummer des Motorrades, die am Lenkrohr eingepägt ist.
- Die Angaben rechts und links beziehen sich auf das Fahrzeug in Fahrriichtung.

## INFORMACIONES GENERALES

El presente catálogo sirve para pedir con exactitud las partes de recambio.  
En los pedidos se debe indicar:

- 1) el número de código de la parte y a continuación la descripción;
  - 2) el color para las piezas barnizadas o coloreadas;
  - 3) el número de matricula de la motocicleta, estampado en le tubo de dirección.
- Las indicaciones derecha e izquierda se refieren a los lados del vehículo respecto del sentido de marcha.

## NOTE - LIST - NOTES - NOTE - NOTAS:

- A** : In alternativa - In alternative - En alternative - Wahlweise - En alternativa  
**D** : In dotazione - To issue - En nécessaire - Ausrüstungsteile - En dotación  
**E** : Ad esaurimento - To fell out - A' finir - Erschöpfung - A agotamiento  
**F** : Fornire assieme - Supply unitedly - Fournir ensemble - Wird zusammen geliefert  
 Equipar juntos  
**H** : Potenziamento per uso sportivo su circuito di gara - Powering for racing use on circuit - Augmentation de la puissance pour usage sportif sur piste - Potenziierung für wettkämpferischen Gebrauch des Motorrad - Aumento de la potencia para uso agonístico sobre circuito de competición  
**M** : Modello **SMS**- **SMS** model - Modéle **SMS**- Modell **SMS** - Modelo **SMS**  
**N** : Non fornito - Not supplied - Ne pas fournit - Keine Gelieferende - No equiparado  
**O** : Non per JPN - Not for JPN - Ne pas pour JPN - Keine für JPN - No por JPN  
**P** : Non per SMR - Not for SMR - Ne pas pour SMR - Keine für SMR - No por SMR  
**Q** : Solo per SMR / U.S.A. - Only for SMR / U.S.A. - Soulement pour SMR / U.S.A.  
 Nur für SMR / U.S.A. - Solo por SMR / U.S.A.  
**R** : A richiesta - Upon request - Sur demande - Auf anfrage - a pedimento  
**S** : Di serie - Supplied - De série - Standard - De serie  
**T** : Modello **TE**- **TE** model - Modéle **TE**- Modell **TE** - Modelo **TE**  
**U** : Solo per TE/ U.S.A. - Only for TE/ U.S.A. - Soulement pour TE/ U.S.A.  
 Nur für TE/ U.S.A. - Solo por TE/ U.S.A.  
**X** : Non per U.S.A. - Not for U.S.A. - Ne pas pour U.S.A. - Keine für U.S.A. - No por U.S.A.  
**Z** : n° denti, number of teeth, numéro dents, Zähne nummer - número dientes

- A** : Austria, Austria, Autriche, Österreich, Austria  
**AUS** : Australia, Australia, Australie, Australien, Australia  
**B** : Belgio, Belgium, Belgique, Belgien, Bélgica  
**BR** : Brasile, Brazil, Brasile, Brésilien, Brasil  
**CDN** : Canada, Canada, Canada, Kanada, Canadá  
**CH** : Svizzera, Switzerland, Suisse, Schweizer, Suiza  
**D** : Germania, Germany, Allemagne, Deutschland, Alemania  
**E** : Spagna, Spain, Espagne, Spanien, España  
**F** : Francia, France, France, Frankreich, Francia  
**GB** : Gran Bretagna, Great Britain, Grand Bretagne, Groos Britan, Gran Bretaña  
**I** : Italia, Italy, Italie, Italien, Italia  
**J** : Giappone, Japan, Japon, Japan, Japón  
**SF** : Finlandia, Finald, Finlande, Finland, Finlandia  
**USA** : Stati Uniti d'America, United States of America, Etats Units d'Amerique, Vereinigte Staaten von Amerika, Estados Unidos

Dati indicativi soggetti a modifiche senza impegno di preavviso.  
 All data are subject to modification without prior notice.  
 Données indicatif sujet au modifications sans obligation de préavis.  
 Änderungen Vorbehalten.  
 Datos indicativos sujetos a modificaciones sin compromiso de preaviso.

N° DI MATRICOLA INIZIALE - INITIAL SERIAL NUMBER - MATRICULE INITIAL - BEGINNTESERIENNUMMER - MATRICULA INICIAL	
MODELLO - MODEL MODELE - MODELL MODELO	MATRICOLA - SERIAL NUMBER MATRICULE - SERIENNUMMER MATRICULA
<b>TE 125</b>	<b>ZKHA500AABV000000</b>
<b>SMS 125</b>	<b>ZKHA500ABBV000000</b>

Tavola Drawing Table Bild Tabla	Denominazione	Description	Designation	Bezeichnung	Denominacion	Pagina Page Seite Paja
1	ATTREZZI DI ASSISTENZA, MANUALI E CATALOGHI	SERVICE TOOLS, MANUALS AND CATALOGS	OUTILS D'ASSISTANCE, MANUELS ET CATALOGUES	HILFAUSRUSTUNG, HANDBUCH UND KATALOG	HERRAMIENTAS DE ASISTENCIA, MANUALESY CATALOGOS	13
2	CILINDRO, PISTONE	CYLINDER, PISTON	CYLINDRE, PISTON	ZYLINDER, KOLBEN	CILINDRO, PISTON	15
3	TESTA CILINDRO	CYLINDER HEAD	CULASSE	ZYLINDERKOPF	CULATA	17
4	MANOVELLISMO	CRANKSHAFT	VILEBREQUIN	KURBELWELLE	CIGÜEÑAL	19
5	DISTRIBUZIONE	VALVE TIMING	DISTRIBUTION	VENTILSTEUERUNG	DISTRIBUCION	21
6	POMPA ACQUA	WATER PUM	POMPE EAU	WASSERPUMP	BONBA AQUA	23
7	LUBRIFICAZIONE	OIL PUMP	PUMPE HUILE	MOTORSCHMIERUNG	LUBRICACION	25
8	CARBURATORE 1/2	CARBURETTOR 1/2	CARBURATEUR 1/2	VERGASER 1/2	CARBURADOR 1/2	27
9	CARBURATORE 2/2	CARBURETTOR 2/2	CARBURATEUR 2/2	VERGASER 2/2	CARBURADOR 2/2	29
10	COPERCHI BASAMENTO 1/2	CRANKCASE COVERS 1/2	COUVERCLES CARTER 1/2	GEHAUSEDECKEL 1/2	TAPAS BANCADA 1/2	31
11	COPERCHI BASAMENTO 2/2	CRANKCASE COVERS 2/2	COUVERCLES CARTER 2/2	GEHAUSEDECKEL 2/2	TAPAS BANCADA 2/2	33
12	FRIZIONE	CLUTCH	EMBRAYAGE	KUPPLUNG	EMBRAGUE	35
13	TRASMISSIONE PRIMARIA	PRIMARY DRIVE	TRANSMISSION PRIMAIRE	PRIMÄRÜBERSETZUNG	TRANSMISION PRIMARIA	37
14	COMANDO CAMBIO 1/2	GEARSHIFT MECHANISM 1/2	COMMANDE DE VITESSE 1/2	GANGSCHALTUNG 1/2	MANDO CAMBIO 1/2	39
15	COMANDO CAMBIO 2/2	GEARSHIFT MECHANISM 2/2	COMMANDE DE VITESSE 2/2	GANGSCHALTUNG 2/2	MANDO CAMBIO 2/2	41
15A	LEVA COMANDO CAMBIO	GEARCHANGE LEVER	LEVIER COMM. VITESSE	SCHALTHEBEL	PALACA DEL CAMBIO	43
16	PARTE ELETTRICA, IMPIANTO ELETTRICO 1/3	IGNITION SISTEM, ELECTRIC SYSTEM 1/3	PARTIES ELECTRIQUE, INSTALLATION ELECTRIQUE 1/3	ELEKTRISCHE TEILE, ELEKTRISHE ANLAGE 1/3	PARTE ELECTRICA, INSTALLACION ELECTRICA 1/3	45
17	PARTE ELETTRICA, IMPIANTO ELETTRICO 2/3	IGNITION SISTEM, ELECTRIC SYSTEM 2/3	PARTIES ELECTRIQUE, INSTALLATION ELECTRIQUE 2/3	ELEKTRISCHE TEILE, ELEKTRISHE ANLAGE 2/3	PARTE ELECTRICA, INSTALLACION ELECTRICA 2/3	47
18	PARTE ELETTRICA, IMPIANTO ELETTRICO 3/3	IGNITION SISTEM, ELECTRIC SYSTEM 3/3	PARTIES ELECTRIQUE, INSTALLATION ELECTRIQUE 3/3	ELEKTRISCHE TEILE, ELEKTRISHE ANLAGE 3/3	PARTE ELECTRICA, INSTALLACION ELECTRICA 3/3	49
19	IMPIANTO DI RAFFREDAMENTO	COOLING SYSTEM	INSTALLATION RAFROIDISSEMENT	SCHMIERUNGSSYSTEM	EQUIPO DE ENFRIAMIENTO	51
20	FILTRO ARIA	AIR FILTER	FILTRE AIRE	LUFTFILTER	FILTRO DE AIRE	53
21	TELAIO, PEDANE	FRAME, FOOT RESTS	CADRE, REPOSE PIEDS	RAHMEN, FUSSBRETT	BASTIDOR, REPOSAPIES	55
22	SOSPENSIONE ANTERIORE	FRONT FORK ASSEMBLY	SUSPENSION AVANT	VORDETELESKOPGABEL	SUSPENSION DELANTERA	59
22A	SOSPENSIONE ANTERIORE	FRONT FORK ASSEMBLY	SUSPENSION AVANT	VORDETELESKOPGABEL	SUSPENSION DELANTERA	61
23	FORCELLONE POSTERIORE	REAR SWING ARM	FOURCHE ARRIERE	HINTERGABEL	HORQUILLA TRASERA	63
24	LEVRAGGI SOSPENSIONI POSTERIORE	REAR SUSPENSION LINKAGE	LEVIER SUSPENSION ARRIERE	HEBELWERK HINTERHAUFHANGUNG	PALANCA SUSPENSION TRASERA	67
25	AMMORTIZZATORE POSTERIORE	REAR SUSPENSION	SUSPENSION ARRIERE	HINTERHAUFHANGUNG	SUSPENSION TRASERA	69
26	MANUBRIO E COMANDI	HANDLEBAR AND CONTROLS	GUIDON ET COMMANDES	LENKER UND STEUERORGANE	MANILLAR Y MANDOS	71

Tavola Drawing Table Bild Tabla	Denominazione	Description	Designation	Bezeichnung	Denominacion	Pagina Page Page Seite Paja
27	PANNELLI, PARAFANGHI, SELLA	PANEL, FENDERS, SEAT,	PANNEAU, GARDE-BOUES, SIEGE,	STREIFEN, KOTFLUGEL, SATTEL	PANELO, GUARDABARROS, SILLIN	73
28	SERBATOIO CARBURANTE, CONVOGLIATORI	GAS TANK, PANEL	RESERVOIR CARBURANT, FLANC	KRAFTSTOFFBEHALTER, FLANKE	DEPOSITO GASOLINA, LATERAL	77
29	SCARICO	EXHAUST SYSTEM	TUYAU D'ECHAPPEMENT	AUSPUFFROHR	TUBO DE ESCAPE	79
30	FRENO IDRAULICO ANTERIORE	FRONT HYDRAULIC BRAKE	FREIN HYDRAULIQUE AVANT	VORDERBREMSE	FRENO HIDRAULICO DELANTERO	81
31	FRENO IDRAULICO POSTERIORE	REAR HYDRAULIC BRAKE	FREIN HYDRAULIQUE ARRIERE	HINTERBREMSE	FRENO HIDRAULICO TRASERO	83
32	RUOTA ANTERIORE	FRONT WHEEL	ROUE AVANT	VORTERRAD	RUEDA DELANTERA	85
33	RUOTA POSTERIORE	REAR WHEEL	ROUE ARRIERE	HINTERRAD	RUEDA TRASERA	87
34	STRUMENTO DIGITALE	DIGITAL INSTRUMENT,	INSTRUMENT DIGITAL	DIGITAL TACHOMETER	INSTRUMENTO DIGITAL	89
35	GRUPPO CAVI, PARTI ELETTRICHE	MAIN WIRING HARNESS, ELECTRICAL PARTS	CABLES PRINCIPAL, PARTIES ELECTRIQUES	KABEL, ELEKTRISCHE KOMPONENTE	GRUPO PRINCIPAL CABLES PARTES ELECTRICAS	91
36	DECALCOMANIE (TE)	TRANSFER (TE)	DECALCOMANIE (TE)	ABZIEHBILD (TE)	CALCOMANIA (TE)	95
37	DECALCOMANIE (SMS)	TRANSFER (SMS)	DECALCOMANIE (SMS)	ABZIEHBILD (SMS)	CALCOMANIA (SMS)	97

Tavola - Drawing - Table - Bild - Tabla

1

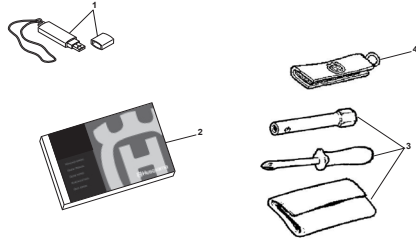

Pagina - Page - Page - Seite - Paja

12

Tavola - Drawing - Table - Bild - Tabla

2

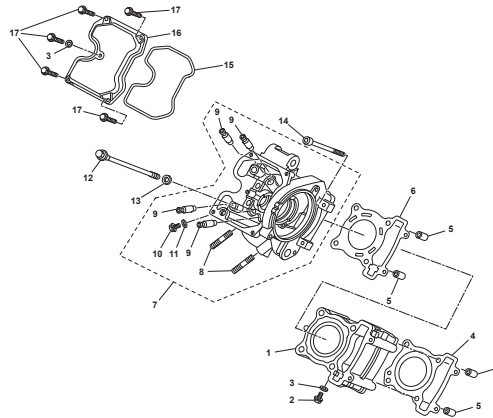

Pagina - Page - Page - Seite - Paja

14

Tavola - Drawing - Table - Bild - Tabla

3

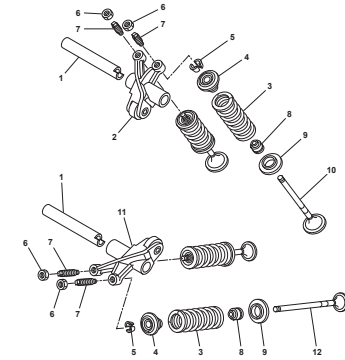

Pagina - Page - Page - Seite - Paja

16

Tavola - Drawing - Table - Bild - Tabla

4

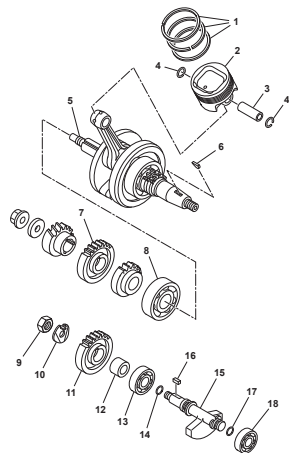

Pagina - Page - Page - Seite - Paja

18

Tavola - Drawing - Table - Bild - Tabla

5

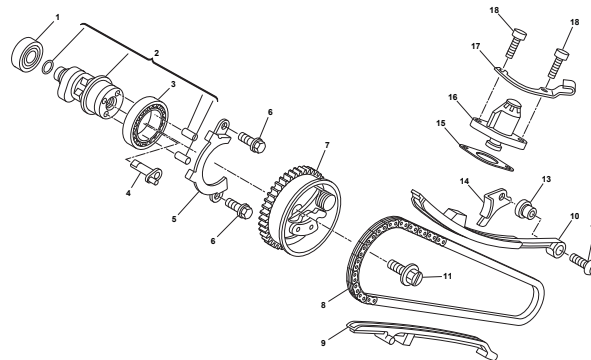

Pagina - Page - Page - Seite - Paja

20

Tavola - Drawing - Table - Bild - Tabla

6

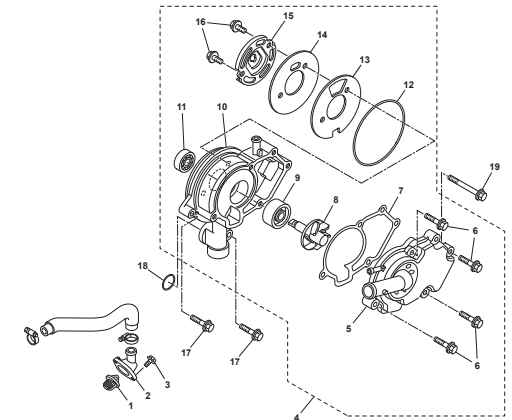

Pagina - Page - Page - Seite - Paja

22



Tavola - Drawing - Table - Bild - Tabla

7

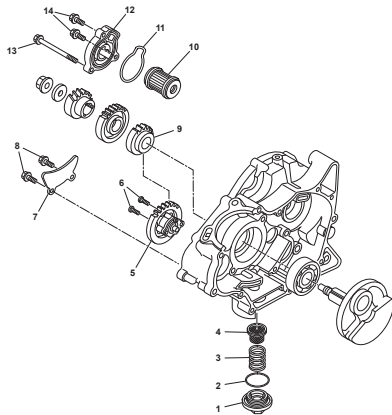

Pagina - Page - Page - Seite - Paja

24

Tavola - Drawing - Table - Bild - Tabla

8

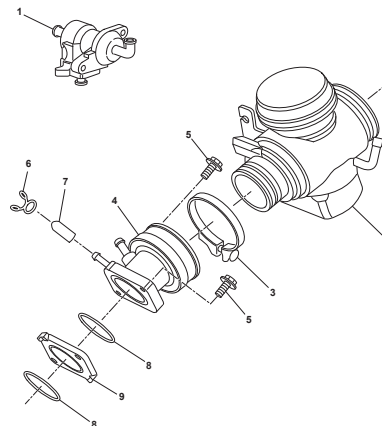

Pagina - Page - Page - Seite - Paja

26

Tavola - Drawing - Table - Bild - Tabla

9

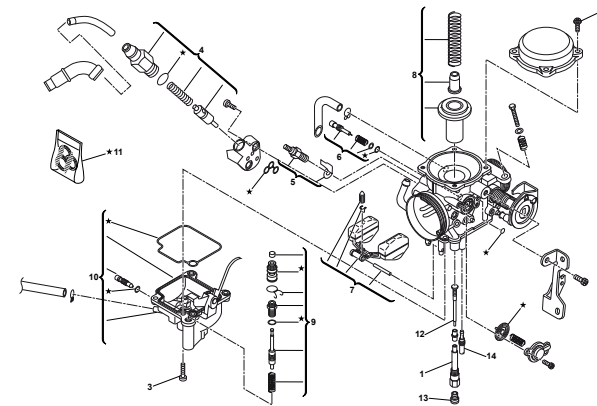

Pagina - Page - Page - Seite - Paja

28

Tavola - Drawing - Table - Bild - Tabla

10

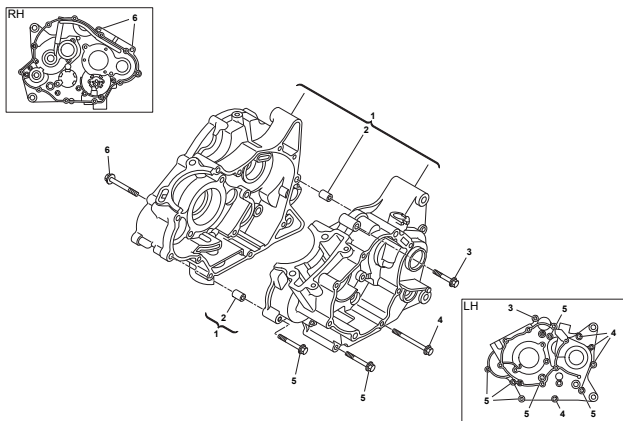

Pagina - Page - Page - Seite - Paja

30

Tavola - Drawing - Table - Bild - Tabla

11

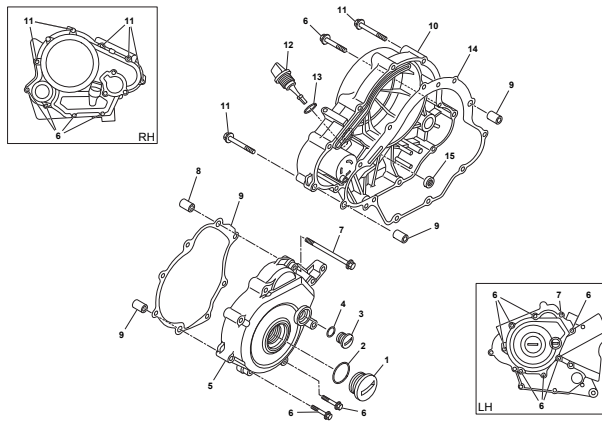

Pagina - Page - Page - Seite - Paja

32

Tavola - Drawing - Table - Bild - Tabla

12

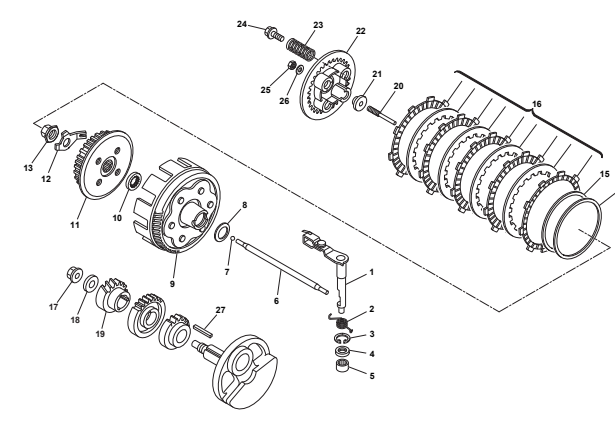

Pagina - Page - Page - Seite - Paja

34

Tavola - Drawing - Table - Bild - Tabla

13

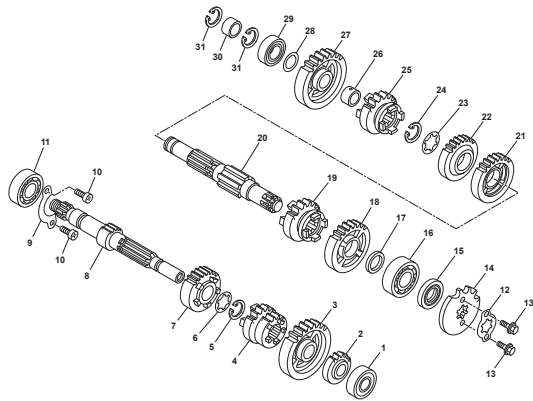

Pagina - Page - Page - Seite - Paja

36

Tavola - Drawing - Table - Bild - Tabla

14

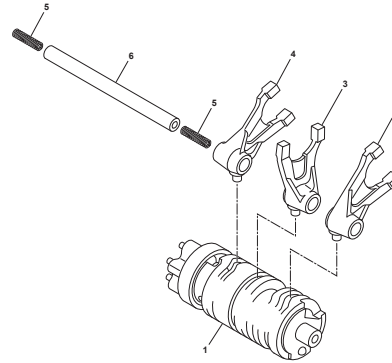

Pagina - Page - Page - Seite - Paja

38

Tavola - Drawing - Table - Bild - Tabla

15

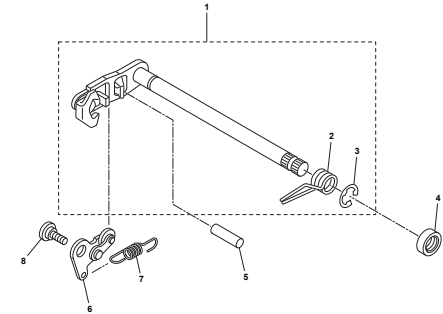

Pagina - Page - Page - Seite - Paja

40

Tavola - Drawing - Table - Bild - Tabla

15A

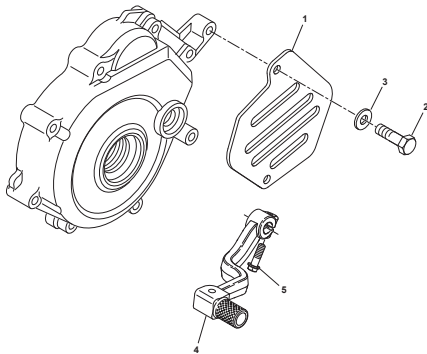

Pagina - Page - Page - Seite - Paja

42

Tavola - Drawing - Table - Bild - Tabla

16

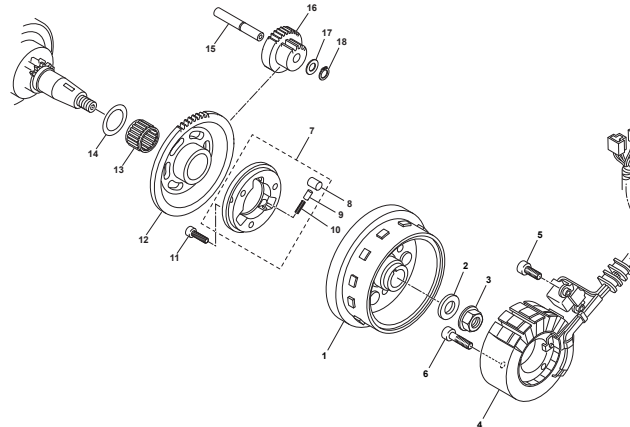

Pagina - Page - Page - Seite - Paja

44

Tavola - Drawing - Table - Bild - Tabla

17

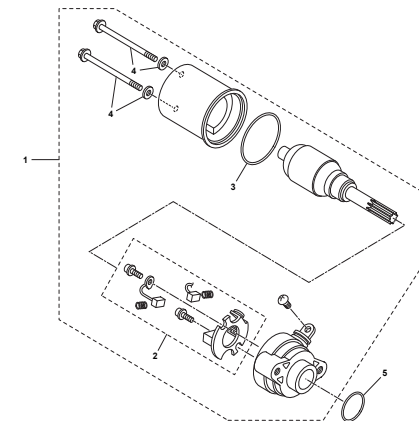

Pagina - Page - Page - Seite - Paja

46

Tavola - Drawing - Table - Bild - Tabla

18

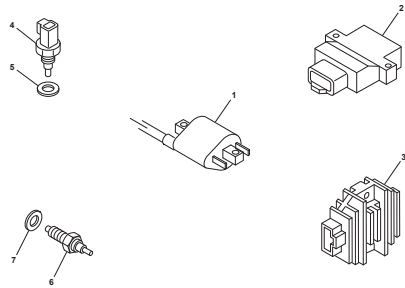

Pagina - Page - Page - Seite - Paja

48

Tavola - Drawing - Table - Bild - Tabla

19

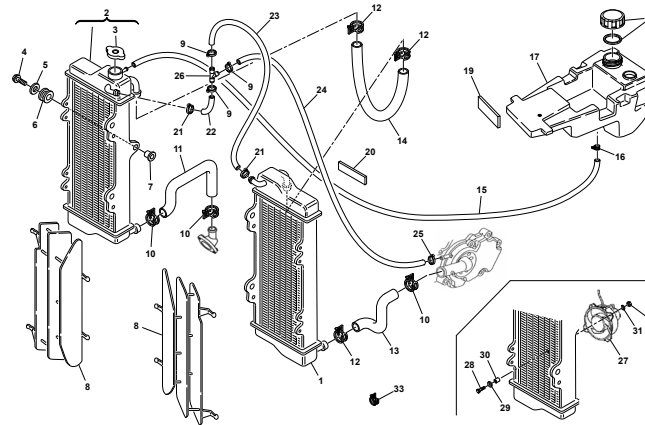

Pagina - Page - Page - Seite - Paja

50

Tavola - Drawing - Table - Bild - Tabla

20

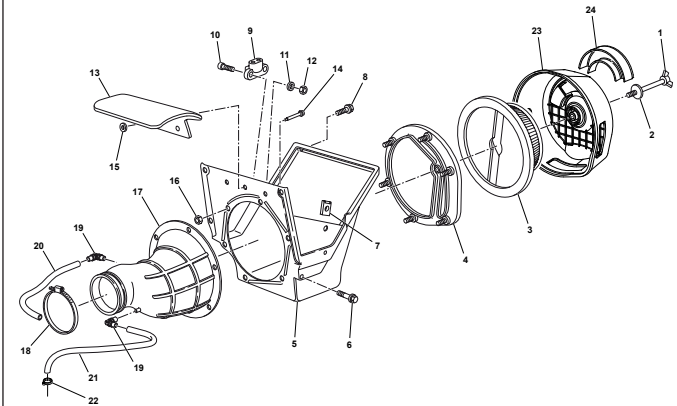

Pagina - Page - Page - Seite - Paja

52

Tavola - Drawing - Table - Bild - Tabla

21

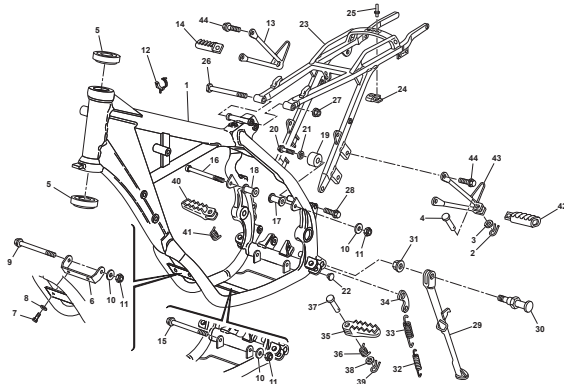

Pagina - Page - Page - Seite - Paja

56

Tavola - Drawing - Table - Bild - Tabla

22

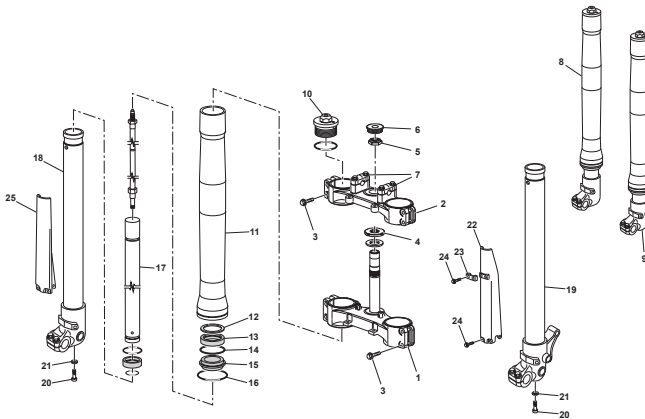

Pagina - Page - Page - Seite - Paja

58

Tavola - Drawing - Table - Bild - Tabla

22A

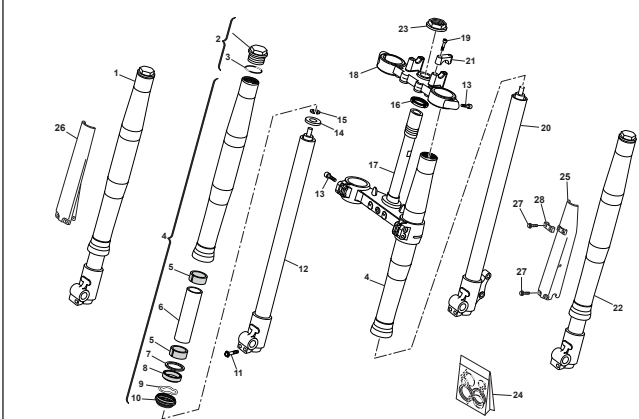

Pagina - Page - Page - Seite - Paja

60



Tavola - Drawing - Table - Bild - Tabla

23

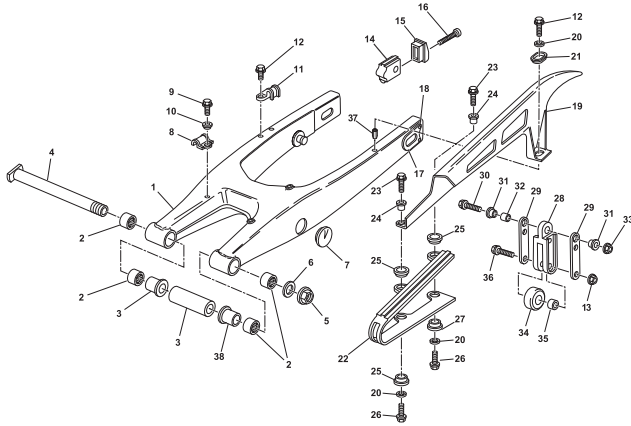

Pagina - Page - Page - Seite - Paja

64

Tavola - Drawing - Table - Bild - Tabla

24

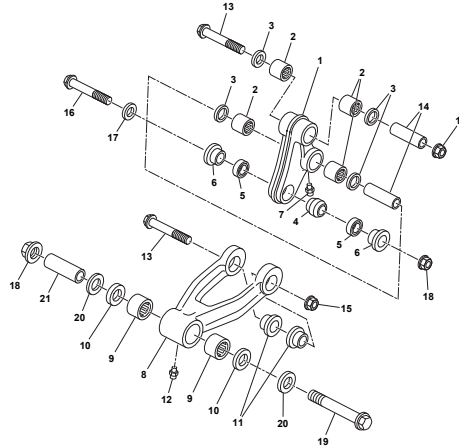

Pagina - Page - Page - Seite - Paja

66

Tavola - Drawing - Table - Bild - Tabla

25

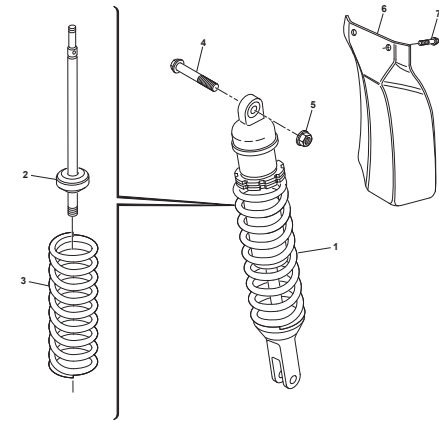

Pagina - Page - Page - Seite - Paja

68

Tavola - Drawing - Table - Bild - Tabla

26

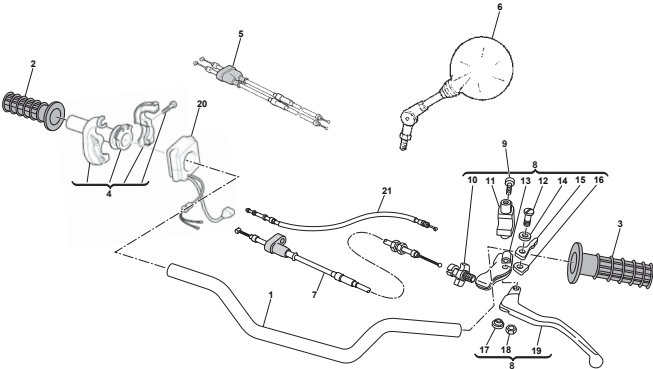

Pagina - Page - Page - Seite - Paja

70

Tavola - Drawing - Table - Bild - Tabla

27

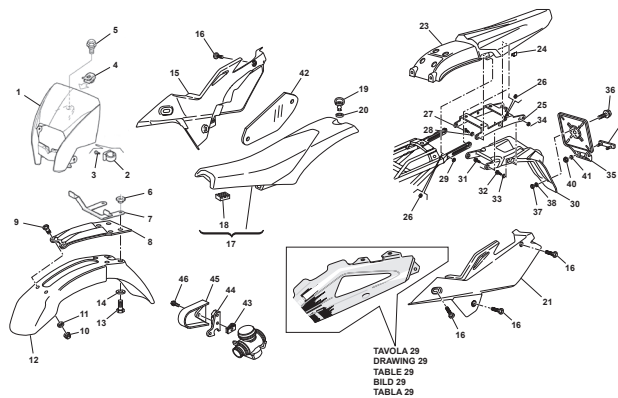

Pagina - Page - Page - Seite - Paja

72

Tavola - Drawing - Table - Bild - Tabla

28

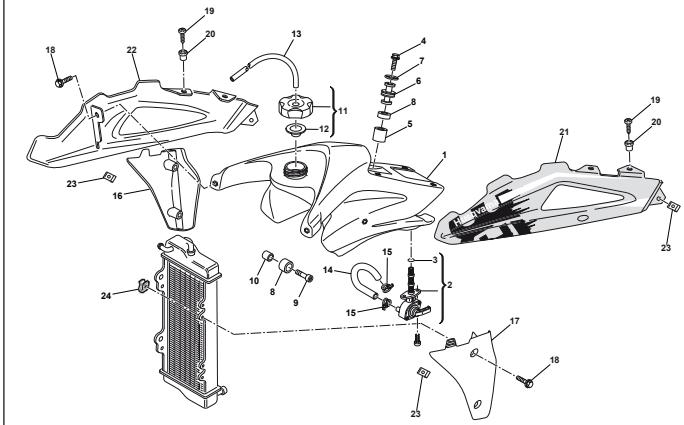

Pagina - Page - Page - Seite - Paja

76

Tavola - Drawing - Table - Bild - Tabla

29

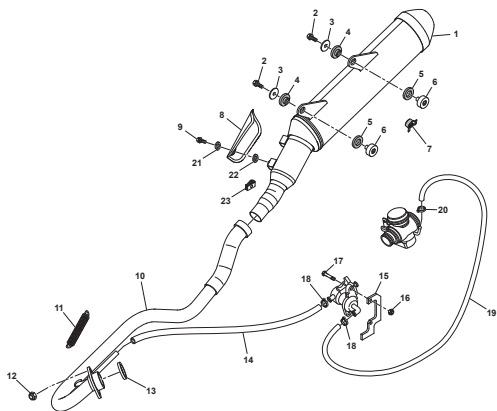

Pagina - Page - Page - Seite - Paja

78

Tavola - Drawing - Table - Bild - Tabla

30

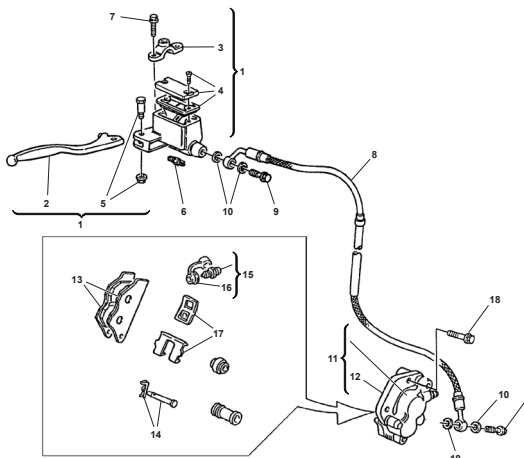

Pagina - Page - Page - Seite - Paja

80

Tavola - Drawing - Table - Bild - Tabla

31

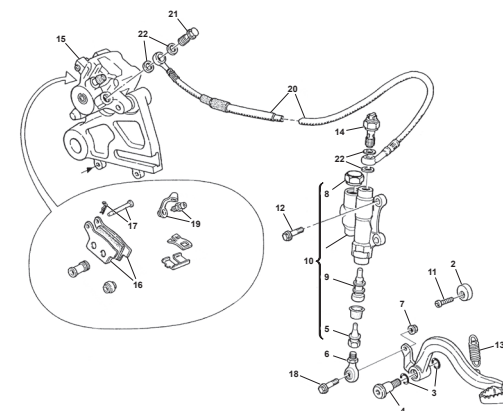

Pagina - Page - Page - Seite - Paja

82

Tavola - Drawing - Table - Bild - Tabla

32

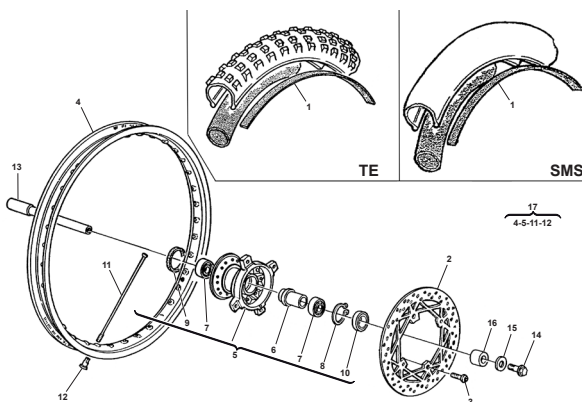

Pagina - Page - Page - Seite - Paja

84

Tavola - Drawing - Table - Bild - Tabla

33

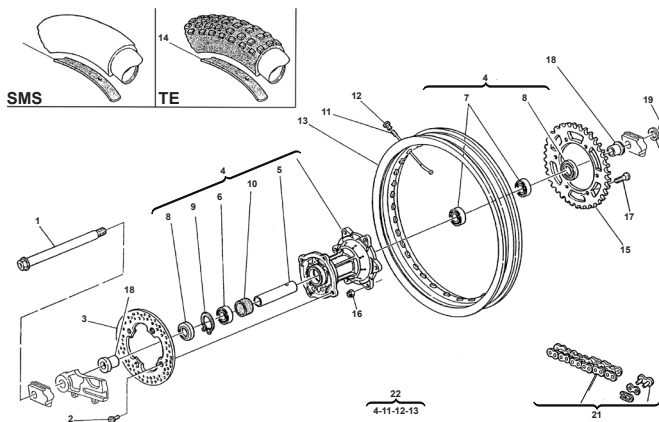

Pagina - Page - Page - Seite - Paja

86

Tavola - Drawing - Table - Bild - Tabla

34

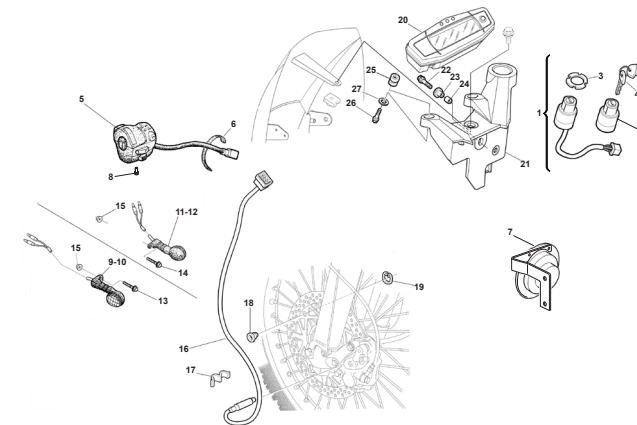

Pagina - Page - Page - Seite - Paja

88

Tavola - Drawing - Table - Bild - Tabla

35

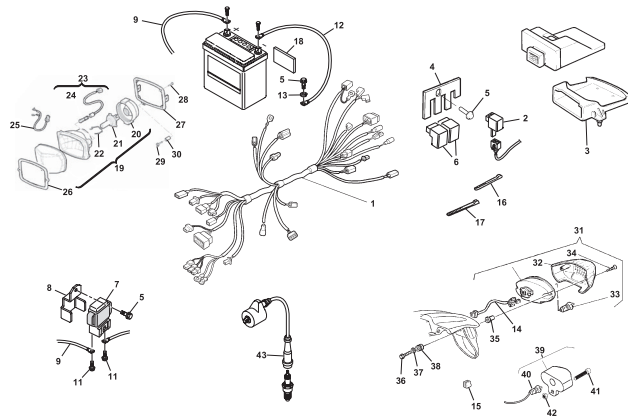

Pagina - Page - Page - Seite - Paja

90

Tavola - Drawing - Table - Bild - Tabla

Tavola - Drawing - Table - Bild - Tabla

36

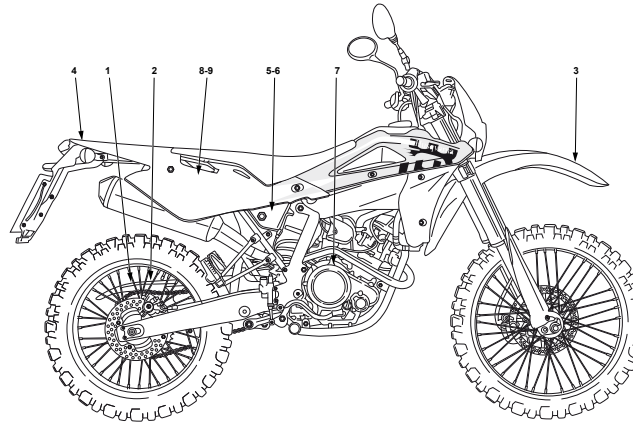

Pagina - Page - Page - Seite - Paja

94

Tavola - Drawing - Table - Bild - Tabla

Tavola - Drawing - Table - Bild - Tabla

37

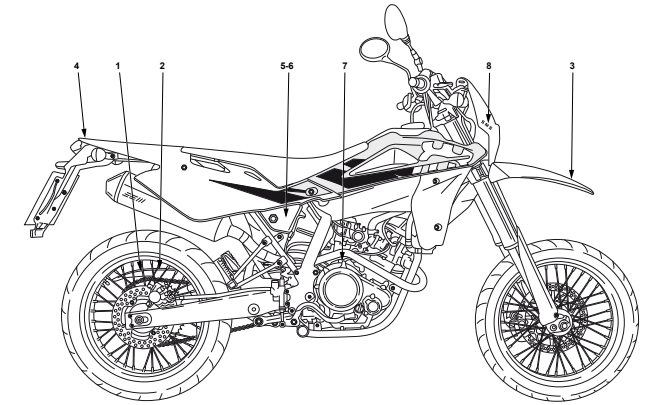

Pagina - Page - Page - Seite - Paja

96

Tavola - Drawing - Table - Bild - Tabla

Pagina - Page - Page - Seite - Paja

Pagina - Page - Page - Seite - Paja

Pagina - Page - Page - Seite - Paja

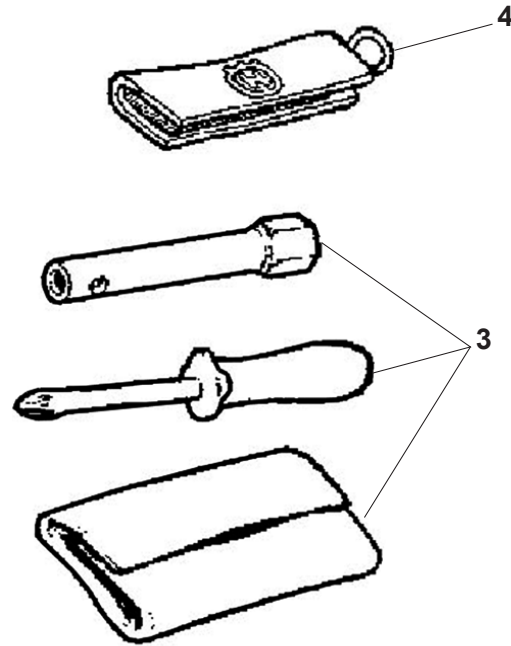
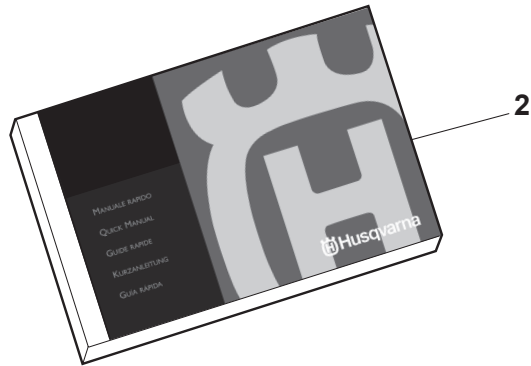
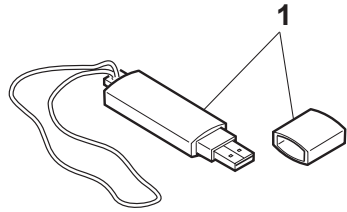



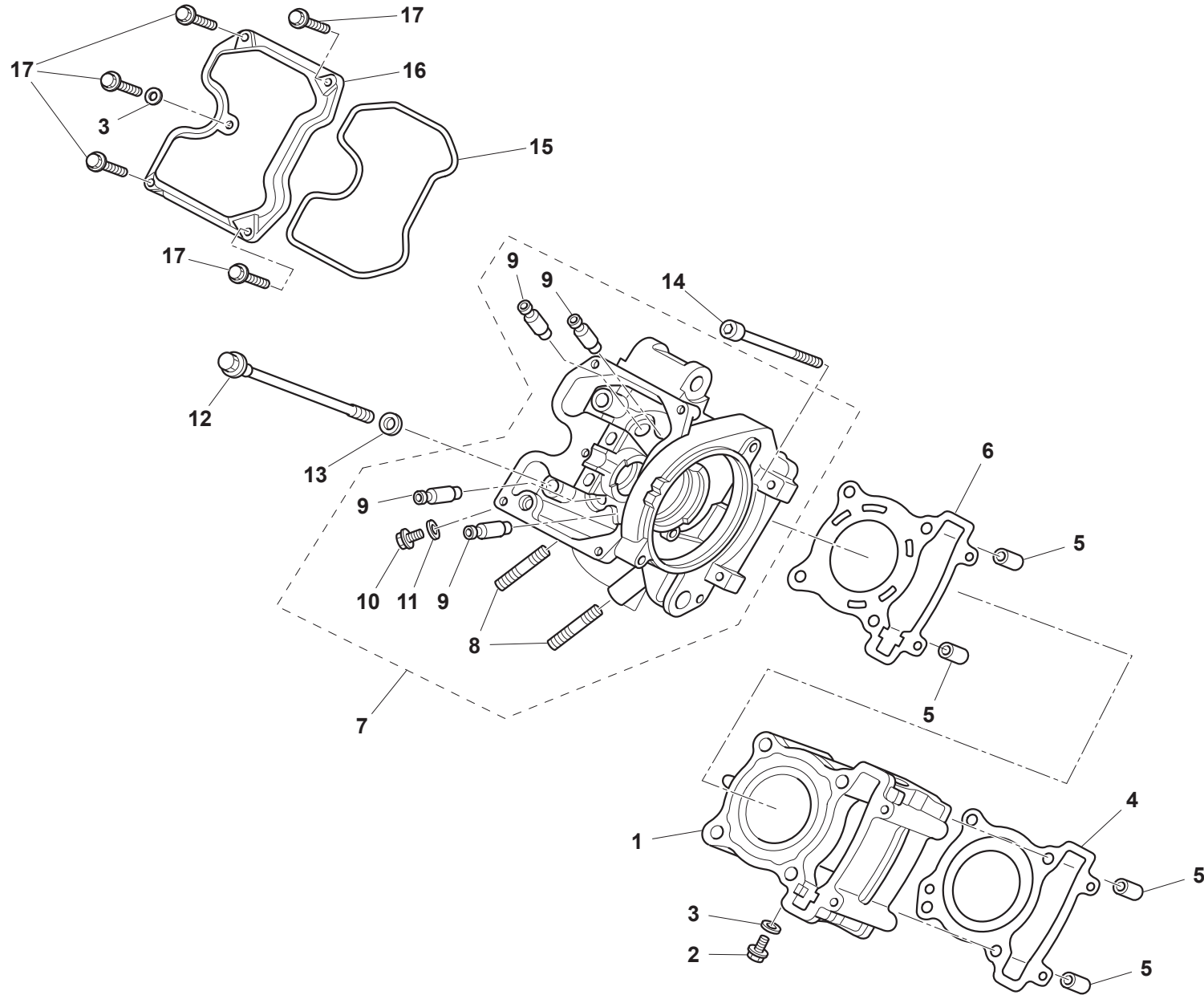



**CILINDRO, PISTONE - CYLINDER, PISTON  
CYLINDRE, PISTON- ZYLINDER, KOLBEN  
CILINDRO, PISTON**

Note Notes Marke Notas	Pos. No. N. Index Pos.	N. Cod. Code No. Nr. Code Code Nr N. Cod.	Q.tà Q.ty Q.te M.ge C.ad	DENOMINAZIONE	NAME	DESIGNATION	BESHREIBUNG	DENOMINACION
	1	8000H4216	1	CILINDRO COMPLETO	CYLINDER ASSY	CYLINDRE COMPLET	ZYLINDER KOMPL	CILINDRO COMPLETO
	2	8000H4397	1	VITE FLANGIATA M6X10	BOLT, FLANGE M6X10	VIS A EMBASE M6X10	FLANSCHENSCHRAUBE M6X10	TORNILLO CON VALONA M6X10
	3	8000H4417	2	RONDELLA IN RAME 6,3X13X1,2	WASHER, COPPER 6.3X13X1.2	RONDELLE EN CUIVRE 6,3X13X1,2	KUPFERSCHEIBE 6,3X13X1,2	ARANDELA COBRE 6,3X13X1,2
	4	8000H4313	1	GUARNIZIONE BASE CILINDRO	GASKET, CYLNDER BASE	JOINT BASE CYLINDRE	DICHTUNG, ZYLINDER	JUNTA BASE CILINDRO
	5	8000H4328	8	GRANO RIFERIMENTO 10X14X8,5	PIN DOWEL 10X14X8.5	GOUJON REFERENCE 10X14X8,5	BEZUGSSTIFT 10X14X8,5	ESPIGA REFERENCIA 10X14X8,5
	6	8000H4319	1	GUARNIZIONE TESTA CILINDRO	GASKET, CYLINDER HEAD	JOINT CULASSE	DICHTUNG ZYLINDERKOPF	JUNTA CULATA
	7	8000H4219	1	TESTA CILINDRO	CYLINDER HEAD	CULASSE	ZYLINDERKOPF	CULATA
	8	8000H4378	2	PRIGIONIERO	BOLT, STUD	GOUJON	STIFTSCHRAUBE	ESPARRAGO
	9	8000H4302	4	GUIDA VALVOLA	GUIDE, VALVE	GUIDE SOUPAPE	VENTILFUEHRUNG	GUIA-VALVULA
	10	8000H4397	1	VITE FLANGIATA M6X10	BOLT, FLANGE M6X10	VIS A EMBASE M6X10	FLANSCHENSCHRAUBE M6X10	TORNILLO CON VALONA M6X10
	11	8000H4417	1	RONDELLA IN RAME 6,3X13X1,2	WASHER, COPPER 6.3X13X1.2	RONDELLE EN CUIVRE 6,3X13X1,2	KUPFERSCHEIBE 6,3X13X1,2	ARANDELA COBRE 6,3X13X1,2
	12	8000H4377	2	VITE FLANGIATA M8X1,25X174	BOLT, FLANGE M8X1,25X174	VIS A EMBASE M8X1,25X174	FLANSCHENSCHRAUBE M8X1,25X174	TORNILLO CON VALONA M8X1,25X174
	13	8000H4380	2	RONDELLA IN RAME 8,5X18X2	WASHER, COPPER 8.5X18X2	RONDELLE EN CUIVRE8,5X18X2	KUPFERSCHEIBE 8,5X18X2	ARANDELA COBRE 8,5X18X2
	14	8000H4400	2	VITE TCCE M6X100	SCREW TCCE M6X100	VIS TCCE M6X100	SCHRAUBE TCCE M6X100	TORNILLO TCCE M6X100
	15	8000H4433	1	GUARNIZIONE COPERCHIO VALVOLE	GASKET CYLINDER HEAD COVER	JOINT, COUVERCLE CULASSE	DICHTUNG, ZYLINDERKOPFDECKEL	JUNTA CUBIERTA CULATA
	16	8000H4251	1	COPERCHIO VALVOLE	COVER, CYLINDER HEAD	COUVERCLE CULASSE	DECKEL, ZYLINDERKOPF	CUBIERTA CULATA
	17	8000H4406	5	VITE FLANGIATA M6X20	BOLT, FLANGE M6X20	VIS A EMBASE M6X20	FLANSCHENSCHRAUBE M6X20	TORNILLO CON VALONA M6X20

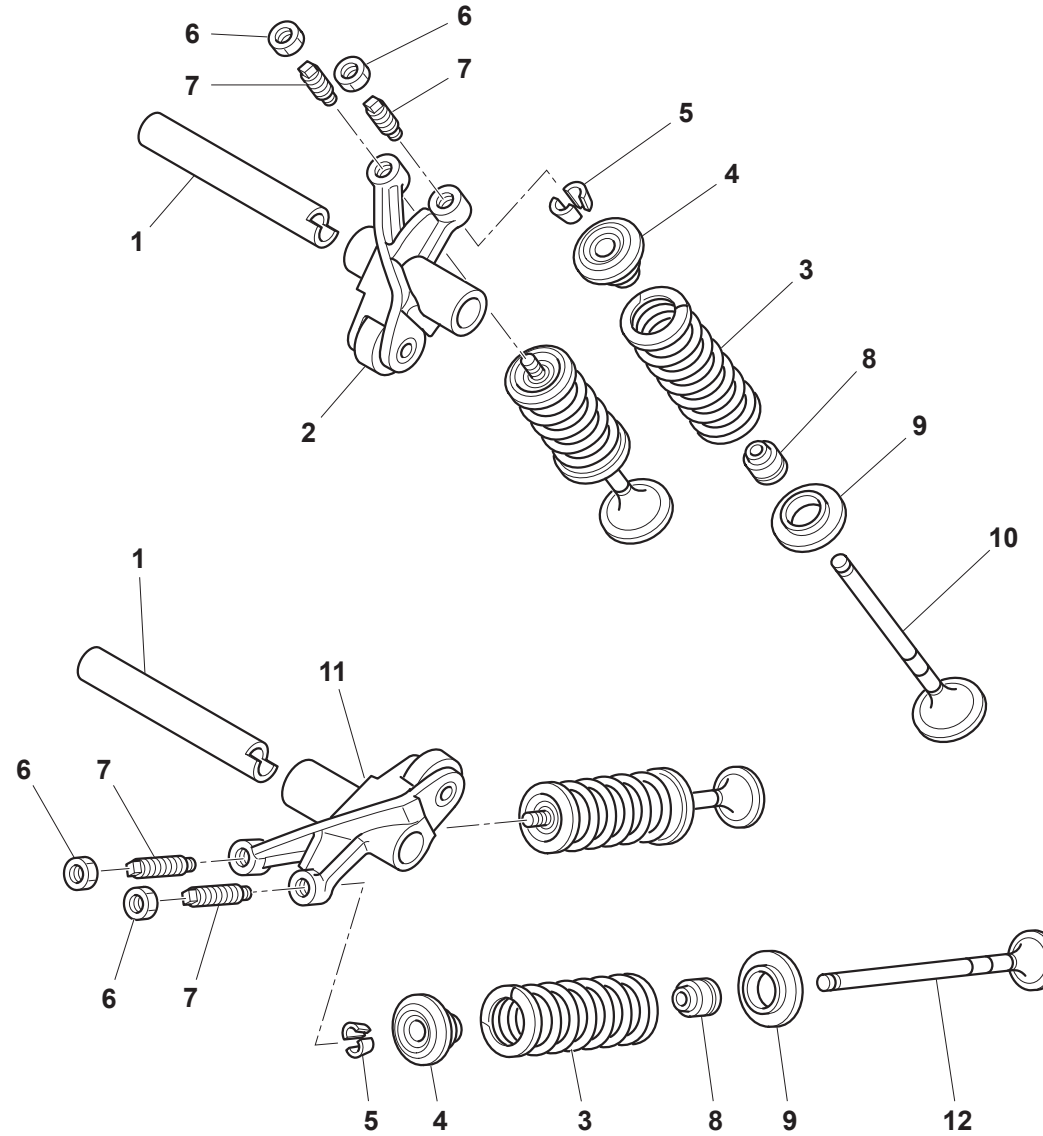



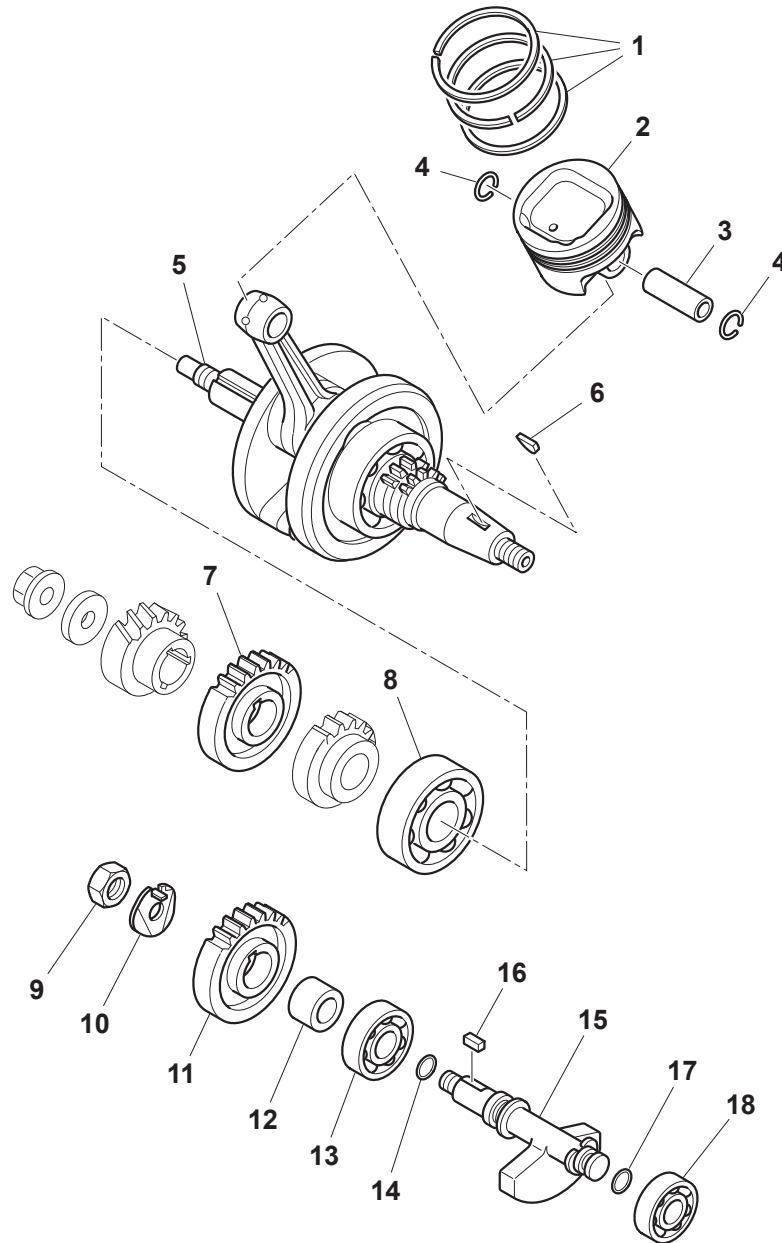



# TE-SMS4 125/2011

## MANOVELLISMO - CRANKSHAFT VILEBREQUIN - KURBELWELLE CIGÜEÑAL

TAVOLA  
DRAWING  
TABLE  
BILD  
TABLA

# 4

Note Notes Marke Notas	Pos. No. N. Index Pos.	N. Cod. Code No. Nr. Code Code Nr. N. Cod.	Q.tà Q.ty Q.te M.ge C.ad	DENOMINAZIONE	NAME	DESIGNATION	BESHREIBUNG	DENOMINACION
	1	8000H4237	1	SERIE SEGMENTI	PISTON RING SET	JEU SEGMENT PISTON	KOLBENRING SATZ	JUEGO ARO PISTON
	2	8000H4218	1	PISTONE	PISTON	PISTON	KOLBEN	PISTON
	3	8000H4338	1	SPINOTTO PISTONE	PIN, PISTON	AXE PISTON	KOLBENBOLZEN	BULON PISTON
	4	8000H4350	2	ANELLINO FERMA SPINOTTO	CLIP PISTON PIN	ATTACHE AXE PISTON	SICHERUNG, KOLBENBOLZEN	GRAPA, BULON PISTON
	5	8000H4229	1	ALBERO MOTORE	CRANKSHAFT	VILEBREQUIN	KURBELWELLE	CIGUENAL
	6	8000H4370	1	CHIAVETTA WOODRUFF 13X3X5	KEY, WOODRUFF 13X3X5	CLAVETTE WOODRUFF 3X3X5	KEIL WOODRUFF 13X3X5	CHAVETA WOODRUFF 13X3X5
	7	8000H4285	1	INGRANAGGIO CONDUTTORE CONTRALBERO	GEAR, BALANCER DRIVE	ENGRANAGE MENANT CONTRE-ARBRE	TREIBENDES ZAHNRAD AUSGLEICHWELLE	ENGRANAJE CONDUCTOR CONTRAARBOL
	8	8000H4308	1	CUSCINETTO A SFERE 25X62X17	BEARING, BALL 25X62X17	ROULEMENT A BILLES 25X62X17	KUGELLAGER 25X62X17	COJINETE DE BOLAS 25X62X17
	9	8000H4372	1	DADO M10X1	NUT M10X1	ECROU M10X1	MUTTER M10X1	TUERCA M10X1
	10	8000H4379	1	RONDELLA SICUREZZA	WASHER, LOCK	RONDELLE VERROULAGE	SICHERUNGSSCHEIBE	ARANDELA CIERRE
	11	8000H4286	1	INGRANAGGIO CONTRALBERO BILANCIAMENTO	GEAR, BALANCER DRIVE	ENGRANAGE CONTRE-ARBRE	ZAHNRAD, AUSGLEICHWELLE	ENGRANAJE CONTRAARBOL
	12	8000H4385	1	DISTANZIALE	SPACER	ENTRETOISE	ABSTANDHALTER	DISTANCIADOR
	13	8000H4306	1	CUSCINETTO A SFERE 35X15X11	BEARING, BALL 35X15X11	ROULEMENT A BILLES 35X15X11	KUGELLAGER 35X15X11	COJINETE DE BOLAS 35X15X11
	14	8000H4437	1	ANELLO O-RING 12,6X2,5	O-RING 12.6X2.5	JOINT TORIQUE 12,6X2,5	O-RING 12,6X2,5	JUNTA TORICA 12,6X2,5
	15	8000H4245	1	CONTRALBERO BILANCIAMENTO	BALANCER, CRANK	ARBRE BALANCIEUR	WELLE, AUSGLEICH	ARBOL BALANCADOR
	16	8000H4368	1	CHIAVETTA WOODRUFF 5X5X6	KEY, WOODRUFF 5X5X6	CLAVETTE WOODRUFF 5X5X6	KEIL WOODRUFF 5X5X6	CHAVETA WOODRUFF 5X5X6
	17	8000H4439	1	ANELLO O-RING 10,8X2,4	O-RING 10.8X2.4	JOINT TORIQUE 10,8X2,4	O-RING 10,8X2,4	JUNTA TORICA 10,8X2,4
	18	8000H4307	1	CUSCINETTO A SFERE 40X17X12	BEARING, BALL 40X17X12	ROULEMENT A BILLES 40X17X12	KUGELLAGER 40X17X12	COJINETE DE BOLAS 40X17X12

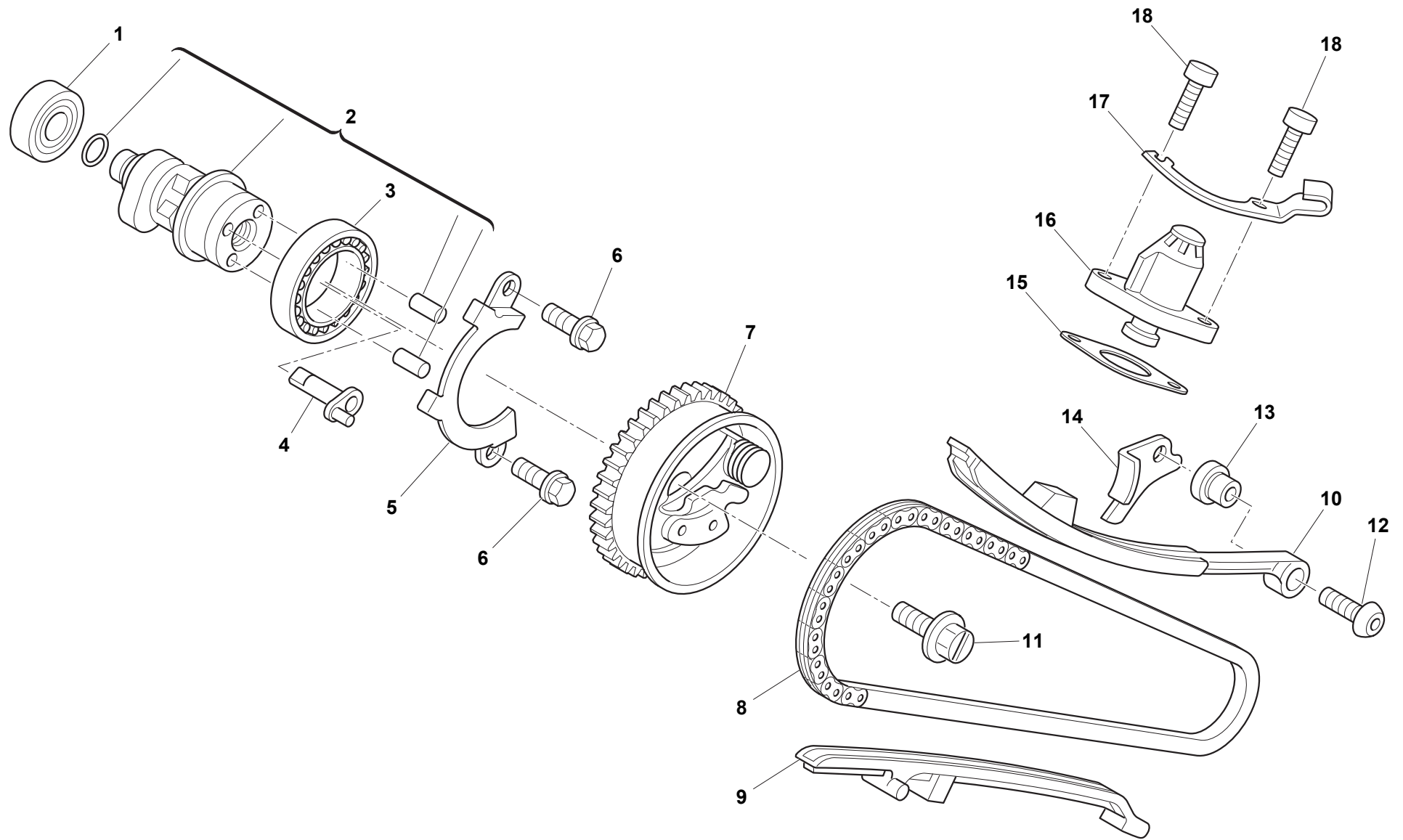





**DISTRIBUZIONE - VALVE TIMING**  
**DISTRIBUTION - VENTILSTEUERUNG**  
**DISTRIBUCION**

Note Notes Marke Notas	Pos. No. N. Index Pos.	N. Cod. Code No. Nr. Code Code Nr N. Cod.	Q.tà Q.ty Q.te M.ge C.ad	DENOMINAZIONE	NAME	DESIGNATION	BESHREIBUNG	DENOMINACION
	1	8000H4427	1	CUSCINETTO A SFERE 6001Z 12X28X8	BEARING, BALL 6001Z 12X28X8	ROULEMENT A BILLES 6001Z 12X28X8	KUGELLAGER 6001Z 12X28X8	COJINETE DE BOLAS 6001Z 12X28X8
	2	8000H4345	1	ALBERO A CAMME	CAM SHAFT	ARBRE A CAMES	NOCKENWELLE	ARBOL LEVAS
	3	8000H4426	1	CUSCINETTO A SFERE 30X47X9	BEARING, BALL 30X47X9	ROULEMENT A BILLES 30X47X9	KUGELLAGER 30X47X9	COJINETE DE BOLAS 30X47X9
	4	8000H4346	1	LEVA DECOMPRESSORE	LEVER, DECOMPRESSION	LEVIER DECOMPRESSEUR	DEKOMPRESSIONS HEBEL	PALANCA DESCOMPRESION
	5	8000H4363	1	PIASTRINA	PLATE	PLAQUETTE	PLAETTCHEN	PLETINA
	6	8000H4391	2	VITE FLANGIATA M6X10	BOLT, FLANGE M6X10	VIS A EMBASE M6X10	FLANSCHENSCHRAUBE M6X10	TORNILLO CON VALONA M6X10
	7	8000H4283	1	DECOMPRESSORE	DECOMPRESSOR	DECOMPRESSEUR	DEKOMPRESSION	DESCOMPRESION
	8	8000H4222	1	CATENA DISTRIBUZIONE	CHAIN, TIMING	CHAINE DISTRIBUTION	STUEWERKETTE	CADENA DISTRIBUCION
	9	8000H4360	1	PATTINO GUIDA CATENA DISTRIBUZIONE	GUIDE, TIMING CHAIN	PATIN GUIDE CHAINE DISTRIBUTION	STUEWERKETTENFUEHRUNG	GUIA CADENA DISTRIBUCION
	10	8000H4361	1	PATTINO TENDICATENA DISTRIBUZIONE	TENSIONER, CAM CHAIN	PATIN TENDEUR CHAINE DISTRIBUTION	STUEWERKETTENGLEITFUEHRUNG	PATIN TENSOR CADENA DISTRIBUCION
	11	8000H4395	1	VITE FLANGIATA M8X1,25 CH12	BOLT, FLANGE M8X1,25 CH12	VIS A EMBASE M8X1,25 CH12	FLANSCHENSCHRAUBE M8X1,25 CH12	TORNILLO CON VALONA M8X1,25 CH12
	12	8000H4409	1	VITE TBCE M6X1X20	SCREW TBCE M6X1X20	VIS TBCE M6X1X20	SCHRAUBE TBCE M6X1X20	TORNILLO TBCE M6X1X20
	13	8000H4383	1	BOCCOLA	BUSH	DOUILLE	BUCHSE	BUJE
	14	8000H4225	1	PROTEZIONE CATENA	GUARD, CHAIN	PROTECTION CHAINE	KETTENSCHUTZ	PROTECCION CADENA
	15	8000H4315	1	GUARNIZIONE TENDICATENA DISTRIBUZIONE	GASKET, TENSIONER ADJUSTER	JOINT TENDEUR CHAINE DISTRIBUTION	DICHTUNG STUEWERKETTENSANNER	JUNTA TENSIONADOR CADENA DISTRIBUCION
	16	8000H4236	1	TENDICATENA DISTRIBUZIONE	TENSIONER, TIMING CHAIN	TENDEUR CHAINE DISTRIBUTION	STUEWERKETTENSANNER	TENSIONADOR CADENA DISTRIBUCION
	17	8000H4364	1	SUPPORTO CAVO FRIZIONE	HOLDER CLUTCH CABLE	PONTET CABLE EMBRAYAGE	KUPPLUNGSKABELBRUECKE	PUENTE CABLE EMBRAGUE
	18	8000H4421	2	VITE TCCE M6X20	SCREW TCCE M6X20	VIS TCCE M6X20	SCHRAUBE TCCE M6X20	TORNILLO TCCE M6X20

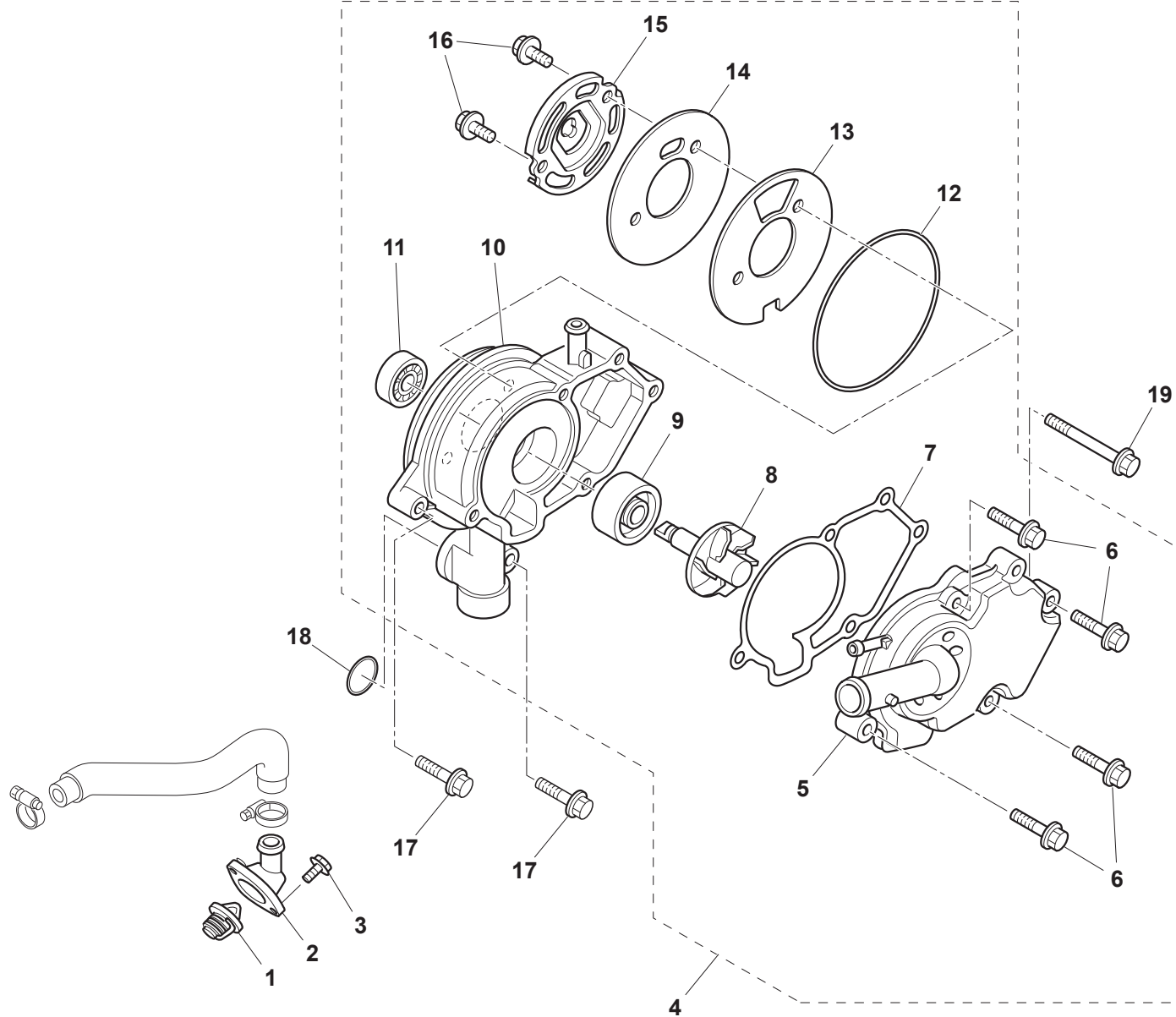



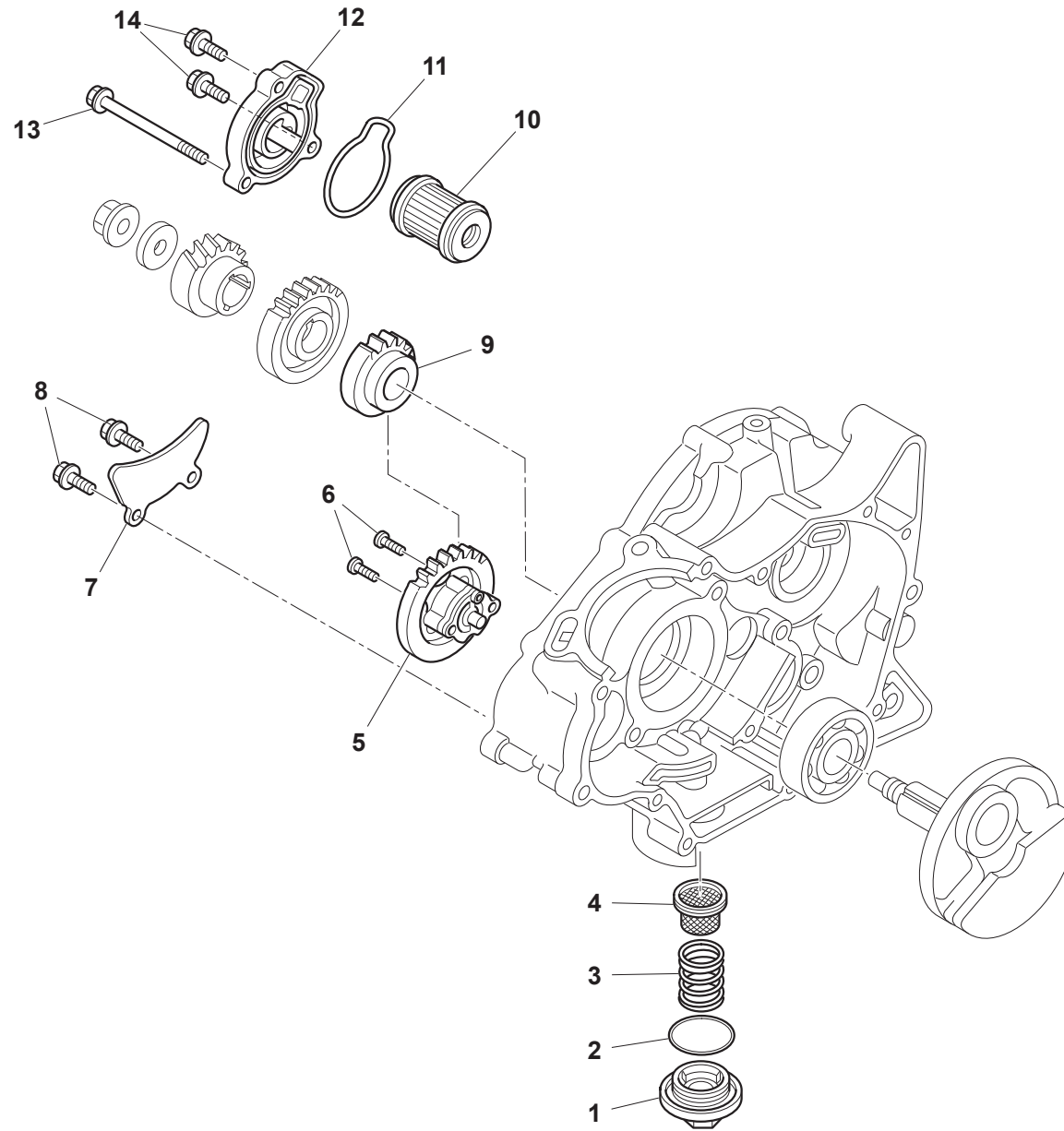



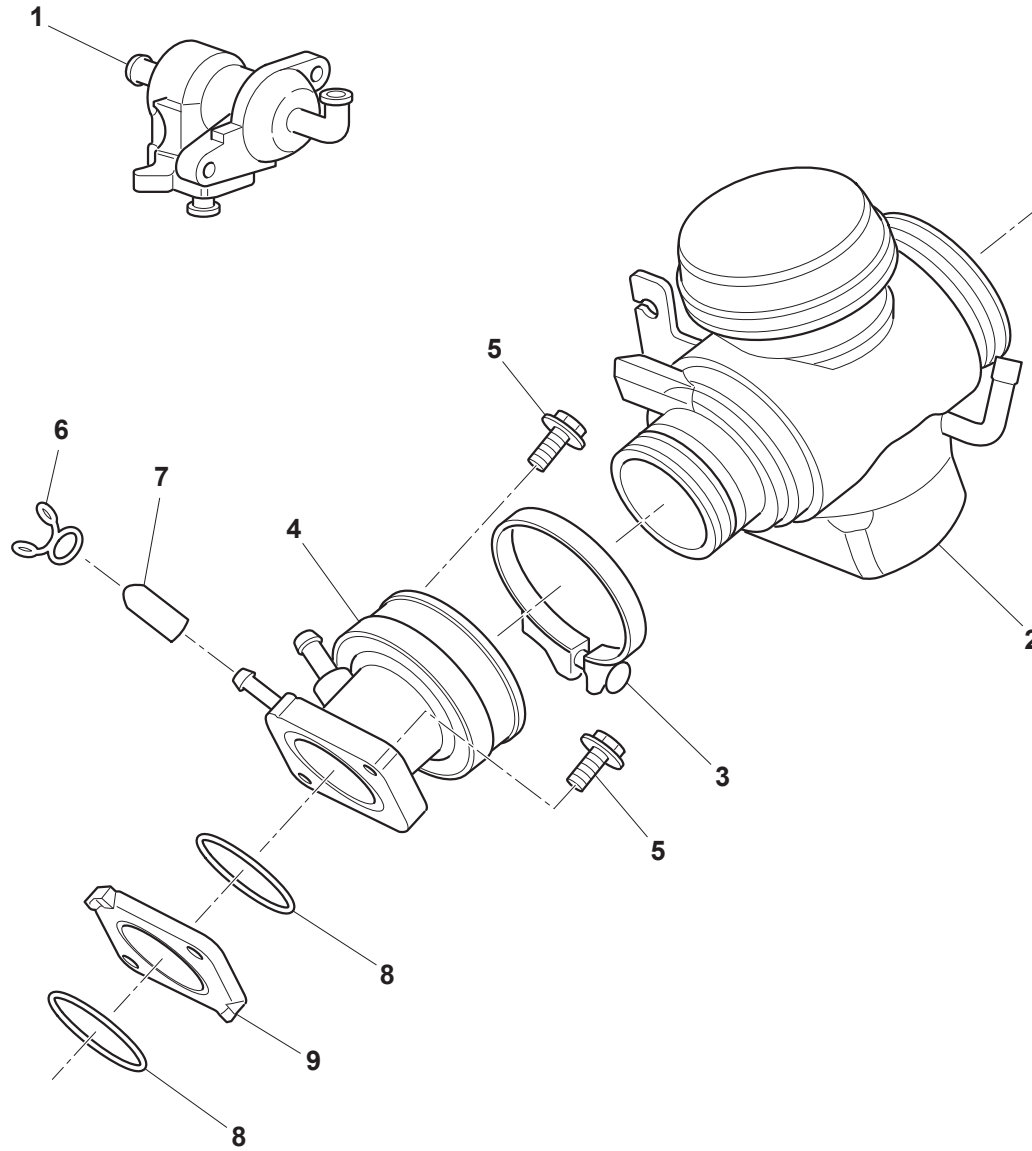





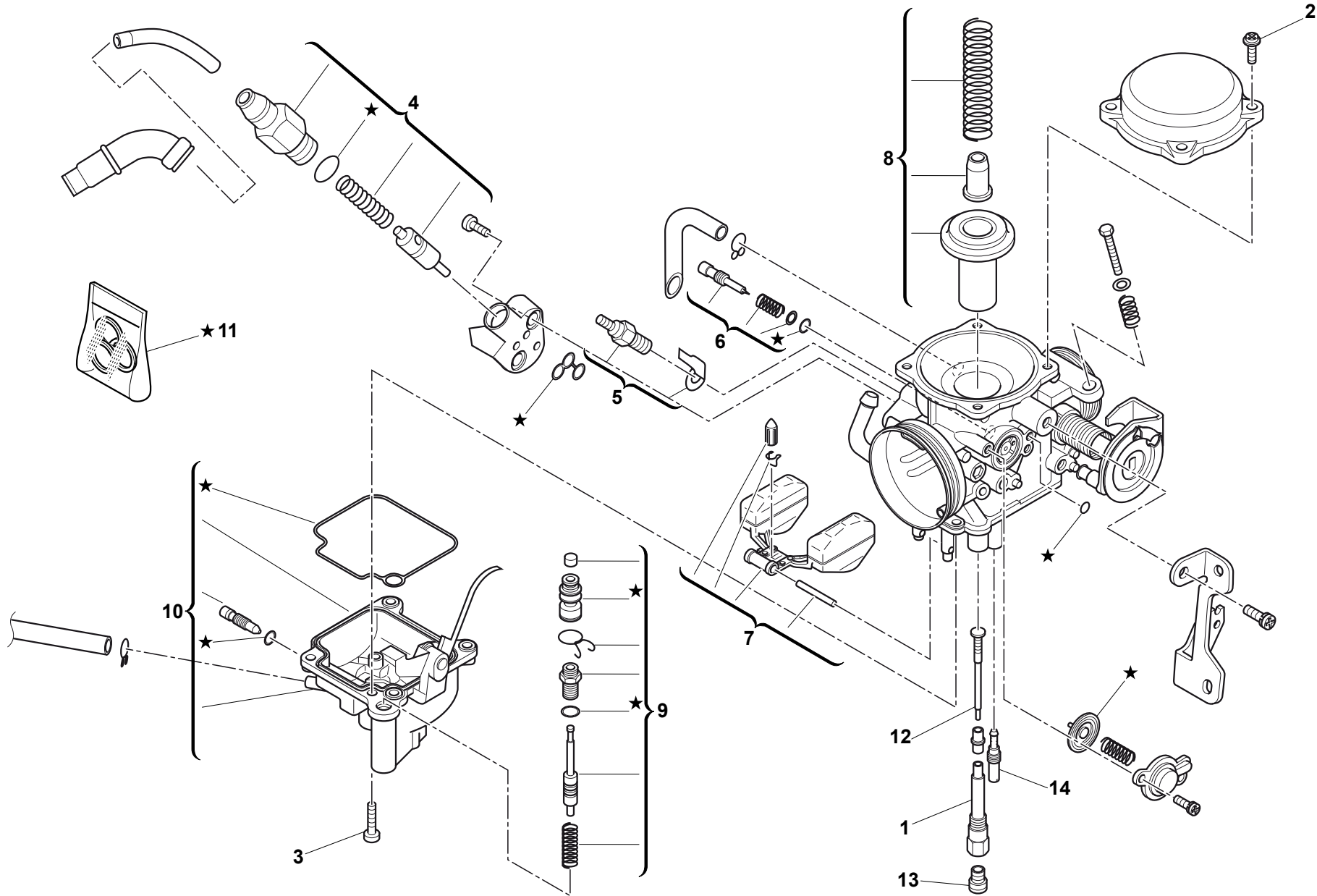



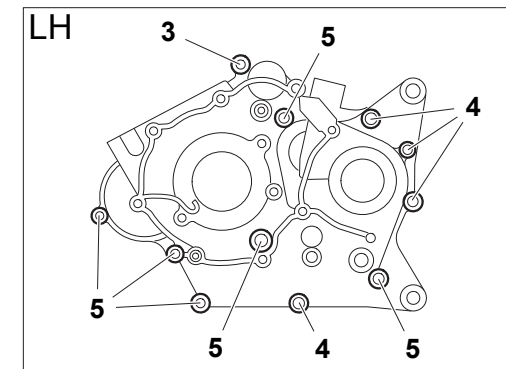
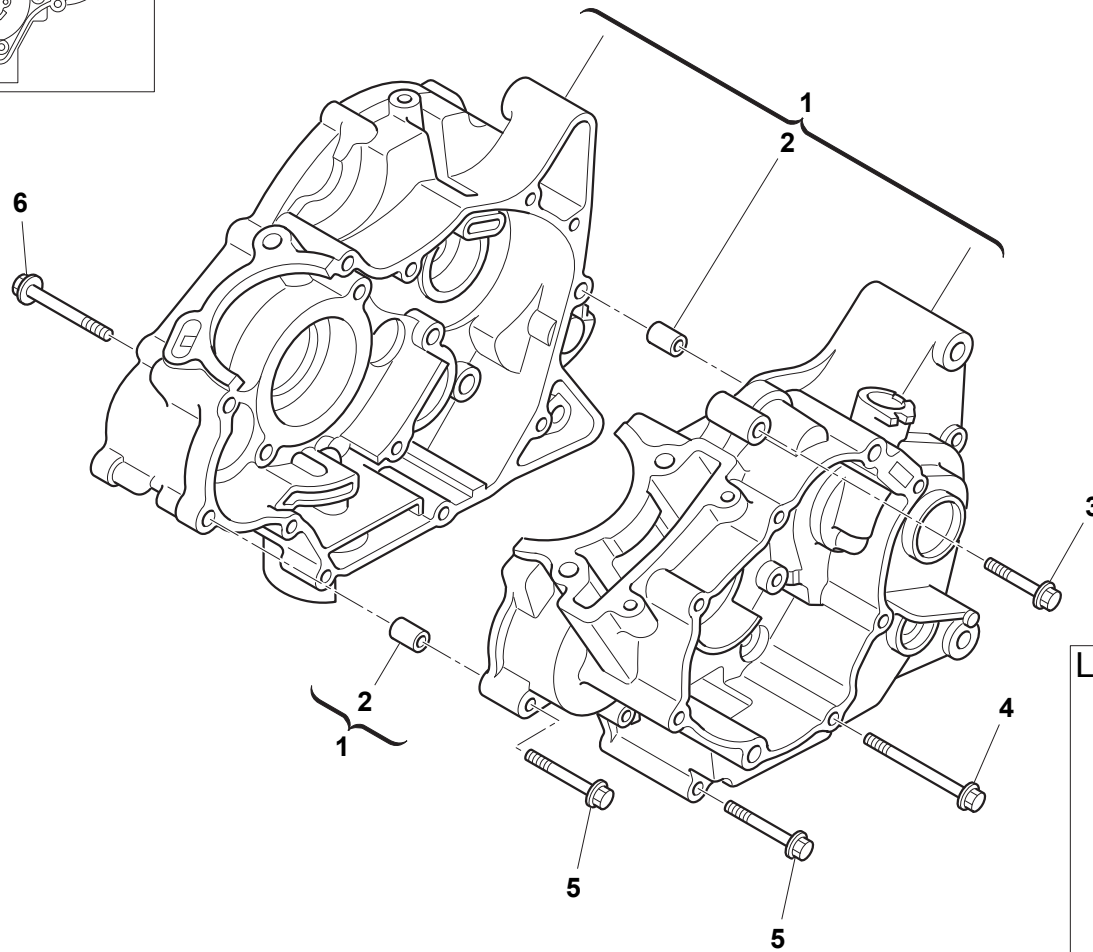
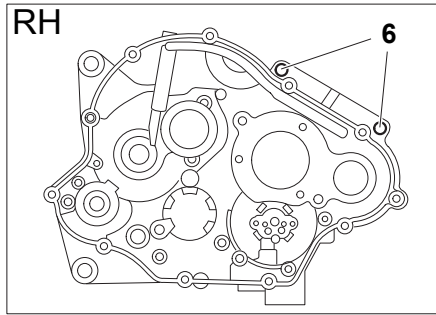



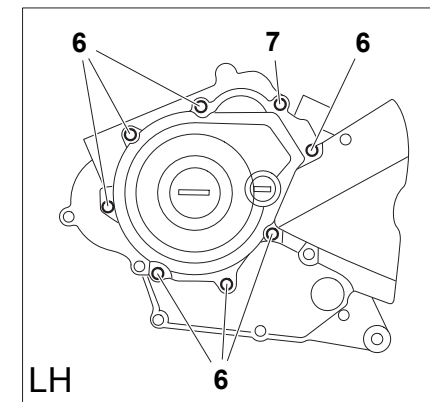
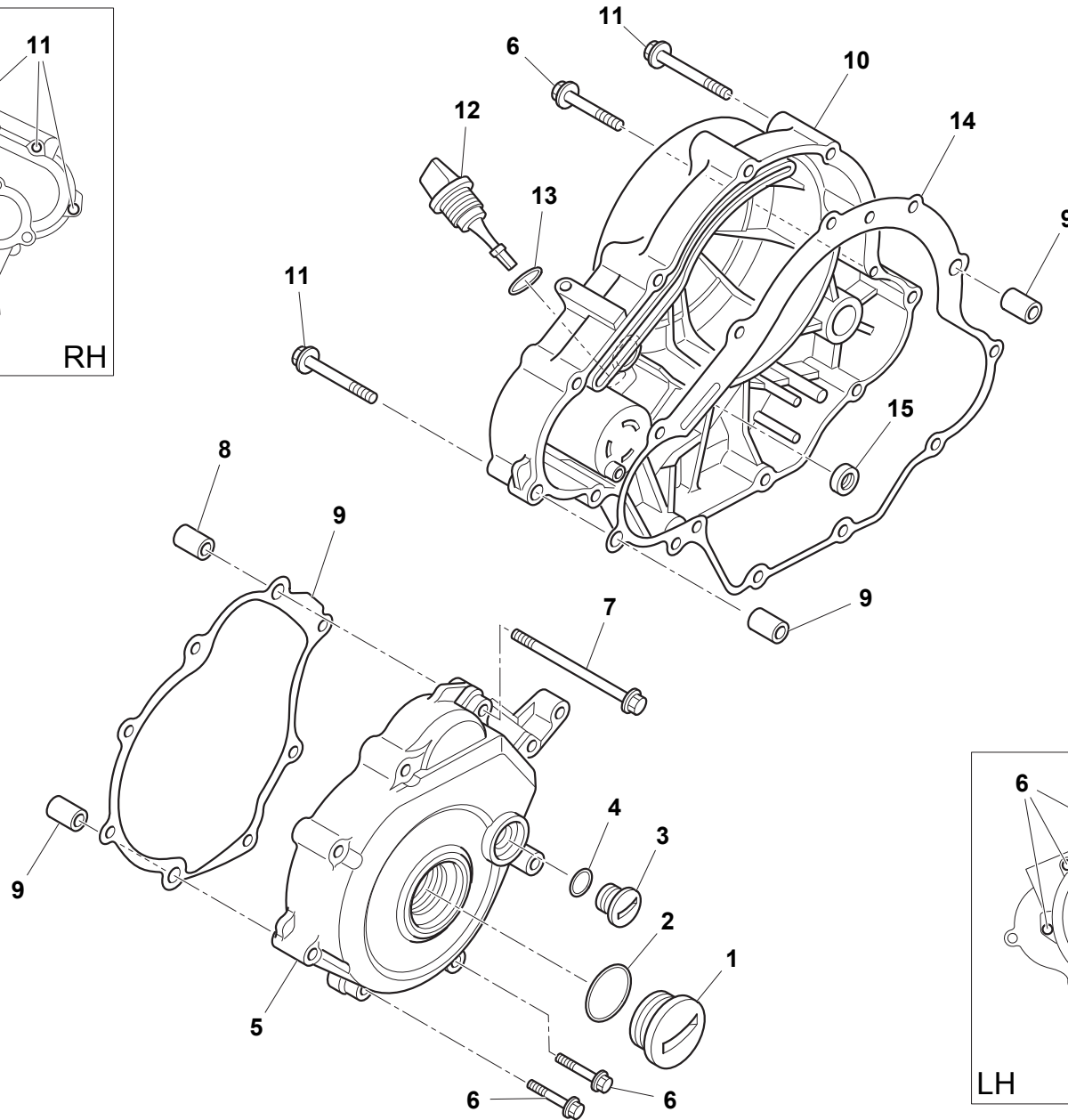
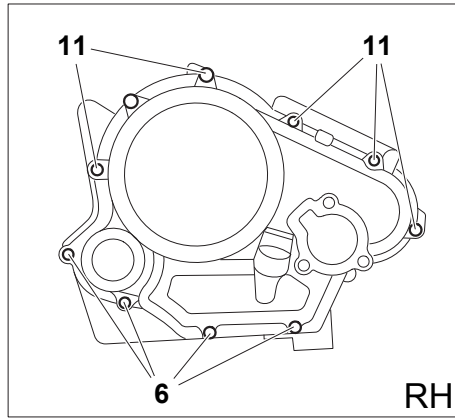



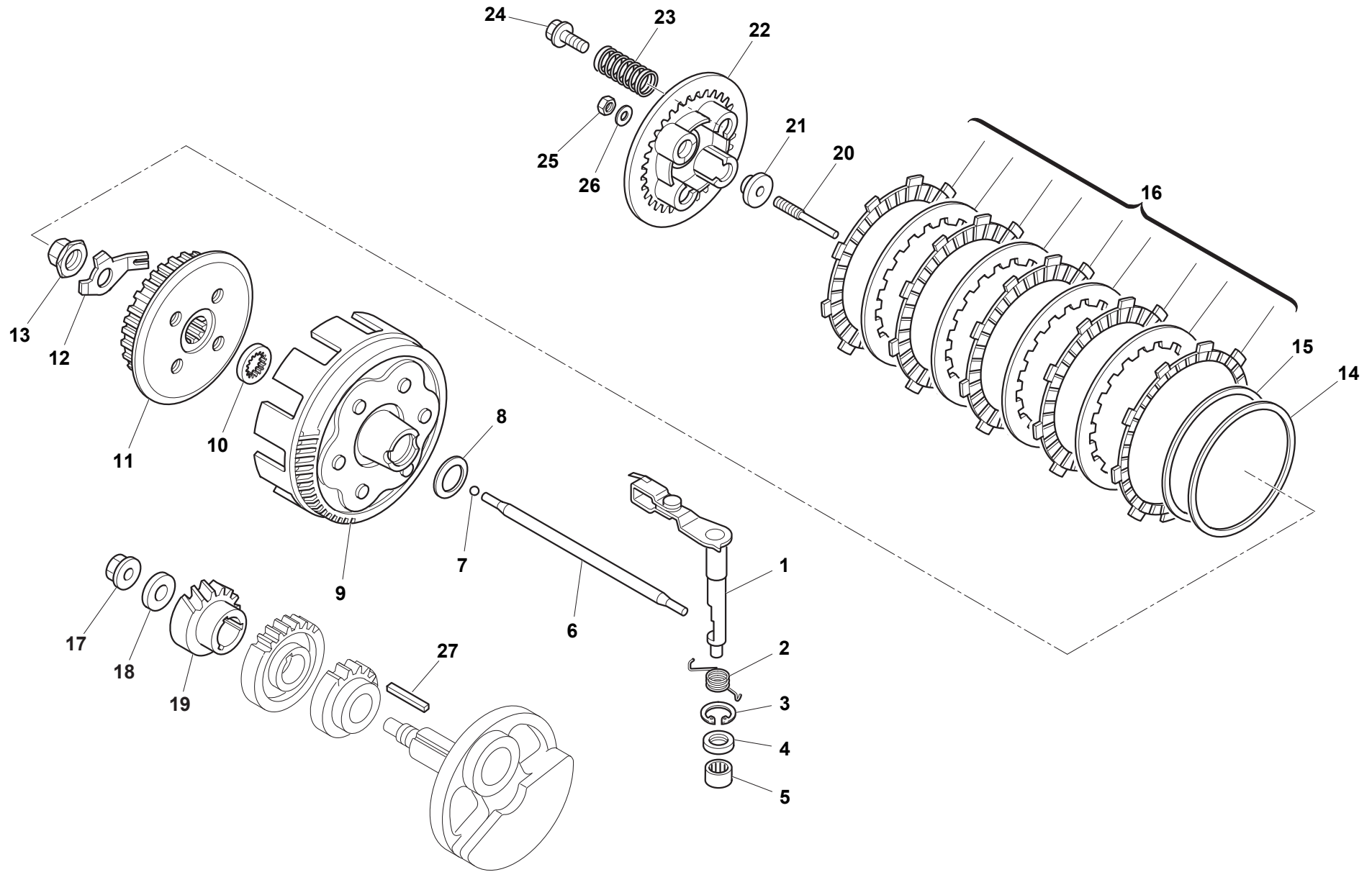



## FRIZIONE - CLUTCH EMBAYAGE - KUPPLUNG EMBRAGUE

Note Notes Marke Notas	Pos. No. N. Index Pos.	N. Cod. Code No. Nr. Code Code Nr N. Cod.	Q.tà Q.ty Q.te M.ge C.ad	DENOMINAZIONE	NAME	DESIGNATION	BESHREIBUNG	DENOMINACION
	1	8000H4230	1	LEVA DISINNESTO FRIZIONE	LEVER, CLUTCH RELEASE	LEVIER DEGAGEMENT EMBRAYAGE	HEBEL KUPPLUNG AUSLOESER	PALANCA DESEMBRAGUE
	2	8000H4294	1	MOLLA LEVA DISINNESTO FRIZIONE	SPRING LEVER CLUTCH RELEASE	RESSORT LEVIER DEGAGEMENT EMBRAYAGE	FEDER HEBEL KUPPLUNG AUSLOESER	MUELLE PALANCA DESEMBRAGUE
	3	8000H4352	1	ANELLO SEEGER	CIRCLIP	CIRCLIP	SEEGERRING	ANILLO SEEGER
	4	8000H4324	1	PARAOLIO 18X12X5	OIL SEAL 18X12X5	BAGUE D'ETANCHEITE 18X12X5	WELLENDICHRING 18X12X5	RETEN ACEITE 18X12X5
	5	8000H4301	1	ASTUCCIO A RULLI 12X16X10	BEARING, NEEDLE 12X16X10	ROULEMENT A AIGUILLES 12X16X10	NADELLAGER 12X16X10	COJINETE DE AGUJAS 12X16X10
	6	8000H4337	1	ASTINA SPINGIFRIZIONE	ROD, CLUTCH PUSH	TIGE POUSSEE EMBRAYAGE	KUPPLUNGSGESTAENGE	VARILLA EMPUJE DISCO EMBRAGUE
	7	8000H4312	1	SFERA 3/16 4,76 MM	BALL 3/16 4.76 MM	BILLE 3/16 4.76 MM	KUGEL 3/16 4,76 MM	BOLA 3/16 4,76 MM
	8	8000H4412	1	RONDELLA CONICA 20X28,5X0,3	WASHER, CONICAL SPRING 20X28.5X0.3	RONDELLE CONIQUE 20X28,5X0,3	KEGELSCHIBE 20X28,5X0,3	ARANDELA CONICA 20X28,5X0,3
	9	8000H4256	1	CAMPANA FRIZIONE	CLUTCH HOUSING	CLOCHE EMBRAYAGE	KUPPLUNGSKASTEN	CAMPANA EMBRAGUE
	10	8000H4375	1	DISTANZIALE	SPACER	ENTRETOISE	ABSTANDHALTER	DISTANCIADOR
	11	8000H4270	1	MOZZETTO FRIZIONE	BOSS, CLUTCH	MOYEU EMBRAYAGE PORTE-DISQUE	KUPPLUNGSSCHIBENHALTERNABE	CUBO EMBRAGUE PORTA-DISCOS
	12	8000H4413	1	RONDELLA SICUREZZA	WASHER, LOCK	RONDELLE VERROULAGE	SICHERUNGSSCHIBE	ARANDELA CIERRE
	13	8000H4371	1	DADO M14X1	NUT M14X1	ECROU M14X1	MUTTER M14X1	TUERCA M14X1
	14	8000H4381	1	SEDE MOLLA A TAZZA	SEAT, WAVE WASHER	SIEGE DU RESSORT	FEDERSITZ	ASIENTO MUELLE
	15	8000H4297	1	MOLLA A TAZZA	WASHER BELLEVILLE	RONDELLE BELLEVILLE	SCHEIBE, BELLEVILLE	ARANDELA BELLEVILLE
	16	8000H4697	1	SERIE DISCHI FRIZIONE	CLUTCH DISC SET	JEU DISQUES EMBRAYAGE	KUPPLUNGSSCHIBENGRUPPE	JUEGO DISCOS EMBRAGUE
	17	8000H4393	1	DADO M12X1	NUT M12X1	ECROU M12X1	MUTTER M12X1	TUERCA M12X1
	18	8000H4416	1	RONDELLA 12,2X30X3	WASHER 12.2X30X3	RONDELLE 12,2X30X3	SCHEIBE 12,2X30X3	ARANDELA 12,2X30X3
	19	8000H4269	1	INGRANAGGIO PRIMARIO	GEAR, PRIMARY DRIVE	ENGRENAGE PRIMAIRE	HAUPTZAHNRAD	ENGRANAJE PRIMARIO
	20	8000H4333	1	ASTINA SPINGIFRIZIONE	ROD, CLUTCH PUSH	TIGE POUSSEE EMBRAYAGE	KUPPLUNGSGESTAENGE	VARILLA EMPUJE DISCO EMBRAGUE
	21	8000H4257	1	PUNTALINO FRIZIONE	PIECE, CLUTCH PUSH	BARRE PRESSION	DRUCKSTANGE	VARILLA PRESION EMBRAGUE
	22	8000H4264	1	DISCO PORTAMOLLE FRIZIONE	DISC, CLUTCH PRESSURE	DISQUE PORTE-RESSORT EMBRAYAGE	ANDRUECKTELLER KUPPLUNGSSCHIBE	EMPUJADOR DISCO EMBRAGUE
	23	8000H4296	4	MOLLA FRIZIONE	SPRING, CLUTCH	RESSORT EMBRAYAGE	KUPPLUNGSFEDER	MUELLE EMBRAGUE
	24	8000H4387	4	VITE MOLLA FRIZIONE	BOLT, CLUTCH SPRING	VIS RESSORT EMBRAYAGE	SCHRAUBE KUPPLUNGSFEDER	TORNILLO MUELLE EMBRAGUE
	25	8000H4394	1	DADO	NUT	ECROU	MUTTER	TUERCA
	26	8000H4382	1	RONDELLA	WASHER	RONDELLE	SCHEIBE	ARANDELA
	27	8000H4369	1	CHIAVETTA 5X5X33	KEY 5X5X33	CLAVETTE 5X5X33	KEIL 5X5X33	CHAVETA 5X5X33

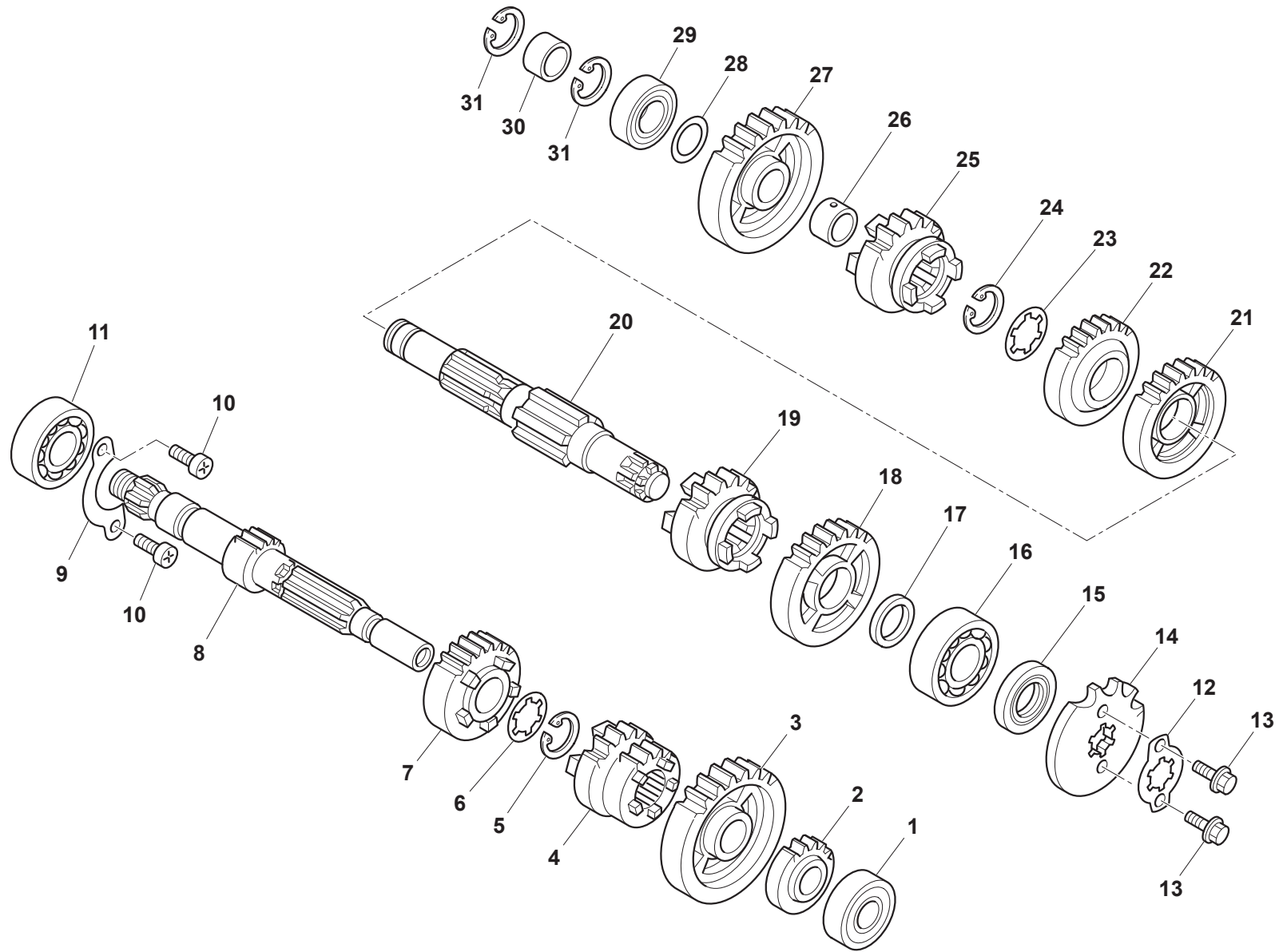

**TRASMISSIONE PRIMARIA - PRIMARY DRIVE**  
**TRANSMISSION PRIMAIR - PRIMÄRÜBERSETZUNG**  
**TRANSMISION PRIMARIA**

Note Notes Marke Notas	Pos. No. N. Index Pos.	N. Cod. Code No. Nr. Code Code Nr. N. Cod.	Q.tà Q.ty Q.te M.ge C.ad	DENOMINAZIONE	NAME	DESIGNATION	BESHREIBUNG	DENOMINACION
	1	8000H4300	1	CUSCINETTO A SFERE 35X15X11	BEARING, BALL 35X15X11	ROULEMENT A BILLES 35X15X11	KUGELLAGER 35X15X11	COJINETE DE BOLAS 35X15X11
	2	8000H4271	1	INGRANAGGIO CONDUTTORE 2A Z16	GEAR DRIVE 2ND SPEED T16	ENGRENAGE MENANT 2EME VITESSE D16	TREIBENDES ZAHNRAD 2, GESCHWIND. Z16	ENGRANAJE CONDUCTOR 2NDA VELOCIDAD D16
	3	8000H4275	1	INGRANAGGIO CONDUTTORE 6A Z25	DRIVING GEAR 6TH SPEED T25	ENGRENAGE CONDUCTEUR 6EME VITESSE D25	ANTRIEBSZAHNRAD 6, GESCHWIND. Z25	ENGRANAJE ACCIONADOR 6A VELOCIDAD D25
	4	8000H4272	1	INGRANAGGIO CONDUTTORE 3A/4A Z22/21	GEAR, 3RD PINION 22T 21T	ENGRENAGE CONDUCTEUR 3EME/4EME D22/21	LEITERZAHNRAD FUER 3.,4. GESCHW.Z22/21	ENGRANAJE ACCIONADOR 3A/4A VEL. Z22/21
	5	8000H4354	1	ANELLO SEEGER	CIRCLIP	CIRCLIP	SEEGERRING	ANILLO SEEGER
	6	8000H4415	1	RONDELLA	WASHER	RONDELLE	SCHEIBE	ARANDELA
	7	8000H4273	1	INGRANAGGIO CONDUTTORE 5A Z23	GEAR, DRIVE 5TH SPEED T23	ENGRENAGE MENANT 5EME VITESSE D23	TREIBENDES ZAHNRAD 5. GESCHWIND. Z23	ENGRANAJE CONDUCTOR 5A VELOCIDAD D23
	8	8000H4241	1	ALBERO PRIMARIO	AXLE, MAIN	ARBRE PRIMAIRE	HAUPTWELLE	ARBOL PRIMARIO CAMBIO
	9	8000H4365	1	PIASTRINA RITEGNO CUSCINETTO	RETAINER, BEARING	PLAQUE ARRET ROULEMENT	STOPPLATTE, LAGER	PLACA RETENCION COJINETE
	10	8000H4423	2	VITE TCCE M6X12	SCREW TCCE M6X12	VIS TCCE M6X12	SCHRAUBE TCCE M6X12	TORNILLO TCCE M6X12
	11	8000H4309	1	CUSCINETTO A SFERE 42X20X12	BEARING, BALL 42X20X12	ROULEMENT A BILLES 42X20X12	KUGELLAGER 42X20X12	COJINETE DE BOLAS 42X20X12
	12	8000H4258	1	PIASTRINA FERMAPIGNONE	PLATE, DRIVE SPROCKET FIXING	PLAQUE FIXATION PIGNON	FIXIERPLATTE, RITZEL	PLACA, FIJACION PINON
	13	8000H4391	2	VITE FLANGIATA M6X10	BOLT, FLANGE M6X10	VIS A EMBASE M6X10	FLANSCHENSCHRAUBE M6X10	TORNILLO CON VALONA M6X10
	14	8000H4231	1	PIGNONE Z14	SPROCKET, CHAIN T14	PIGNON CHAINE Z14	KETTENRITZEL Z14	PINON CADENA Z14
	15	8000H4440	1	PARAOLIO 20X35X5	OIL SEAL 20X35X5	BAGUE D'ETANCHEITE 20X35X5	WELLENDICHRING 20X35X5	RETEN ACEITE 20X35X5
	16	8000H4310	1	CUSCINETTO A SFERE 47X20X14	BEARING, BALL 47X20X14	ROULEMENT A BILLES 47X20X14	KUGELLAGER 47X20X14	COJINETE DE BOLAS 47X20X14
	17	8000H4410	1	RONDELLA	WASHER	RONDELLE	SCHEIBE	ARANDELA
	18	8000H4277	1	INGRANAGGIO CONDOTTO 2A Z30	DRIVEN GEAR 2ND SPEED T30	ENGRENAGE ENTRAINE 2EME VITESSE D30	ANGETRIEBENES ZAHNRAD 2, GESCHWIND.Z30	ENGRANAJE ACCIONADO 2NDA VELOCIDAD D30
	19	8000H4281	1	INGRANAGGIO CONDOTTO 6A Z25	DRIVEN GEAR 6TH SPEED T25	ENGRENAGE ENTRAINE 6EME VITESSE D25	ANGETRIEBENES ZAHNRAD 6. GESCHWIND. Z25	ENGRANAJE ACCIONADO 6A VELOCIDAD D25
	20	8000H4242	1	ALBERO SECONDARIO	COUNTER SHAFT	ARBRE SECONDAIRE	ANTRIEBSWELLE	ARBOL SECONDARIO
	21	8000H4278	1	INGRANAGGIO CONDOTTO 3A Z30	DRIVEN GEAR 3TH SPEED T30	ENGRENAGE ENTRAINE 3EME VITESSE D30	ANGETRIEBENES ZAHNRAD 3. GESCHWIND. Z30	ENGRANAJE ACCIONADO 3ERA VELOCIDAD D30
	22	8000H4279	1	INGRANAGGIO CONDOTTO 4A Z24	DRIVEN GEAR 4TH SPEED T:24	ENGRENAGE ENTRAINE 4EME VITESSE D24	ANGETRIEBENES ZAHNRAD 4. GESCHWIND. Z24	ENGRANAJE ACCIONADO 4A VELOCIDAD D24
	23	8000H4414	1	RONDELLA	WASHER	RONDELLE	SCHEIBE	ARANDELA
	24	8000H4351	1	ANELLO SEEGER	CIRCLIP	CIRCLIP	SEEGERRING	ANILLO SEEGER
	25	8000H4280	1	INGRANAGGIO CONDOTTO 5A Z22	DRIVEN GEAR 5TH SPEED T22	ENGRENAGE ENTRAINE 5EME VITESSE D22	ANGETRIEBENES ZAHNRAD 5. GESCHWIND. Z22	ENGRANAJE ACCIONADO 5A VELOCIDAD D22
	26	8000H4303	1	BRONZINA INGRANAGGIO	BUSH, GEAR	COUSSINET ENGRANAGE	GLEITLAGER, ZHANRAD	COJINETE PLANO ENGRANAJE
	27	8000H4276	1	INGRANAGGIO CONDOTTO 1A Z34	DRIVEN GEAR 1ST SPEED T34	ENGRENAGE ENTRAINE 1ERE VITESSE D34	ANGETRIEBENES ZAHNRAD 1. GESCHWIND. Z34	ENGRANAJE ACCIONADO 1ERA VELOCIDAD D34
	28	8000H4411	1	RONDELLA	WASHER	RONDELLE	SCHEIBE	ARANDELA
	29	8000H4311	1	CUSCINETTO A SFERE 35X17X10	BEARING, BALL 35X17X10	ROULEMENT A BILLES 35X17X10	KUGELLAGER 35X17X10	COJINETE DE BOLAS 35X17X10
	30	8000H4355	2	ANELLO SEEGER	CIRCLIP	CIRCLIP	SEEGERRING	ANILLO SEEGER
	31	8000H4384	1	DISTANZIALE	SPACER	ENTRETOISE	ABSTANDHALTER	DISTANCIADOR

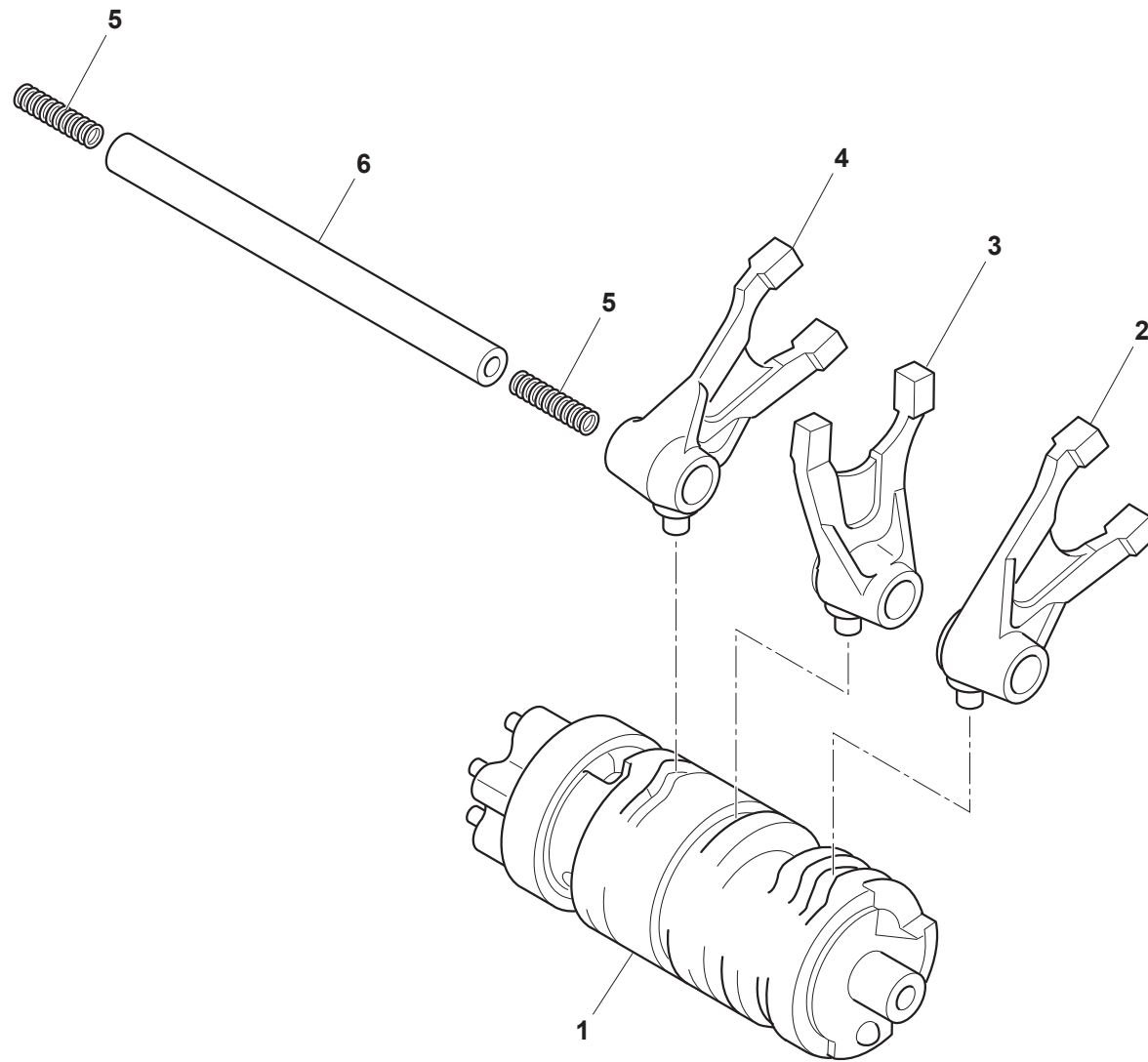



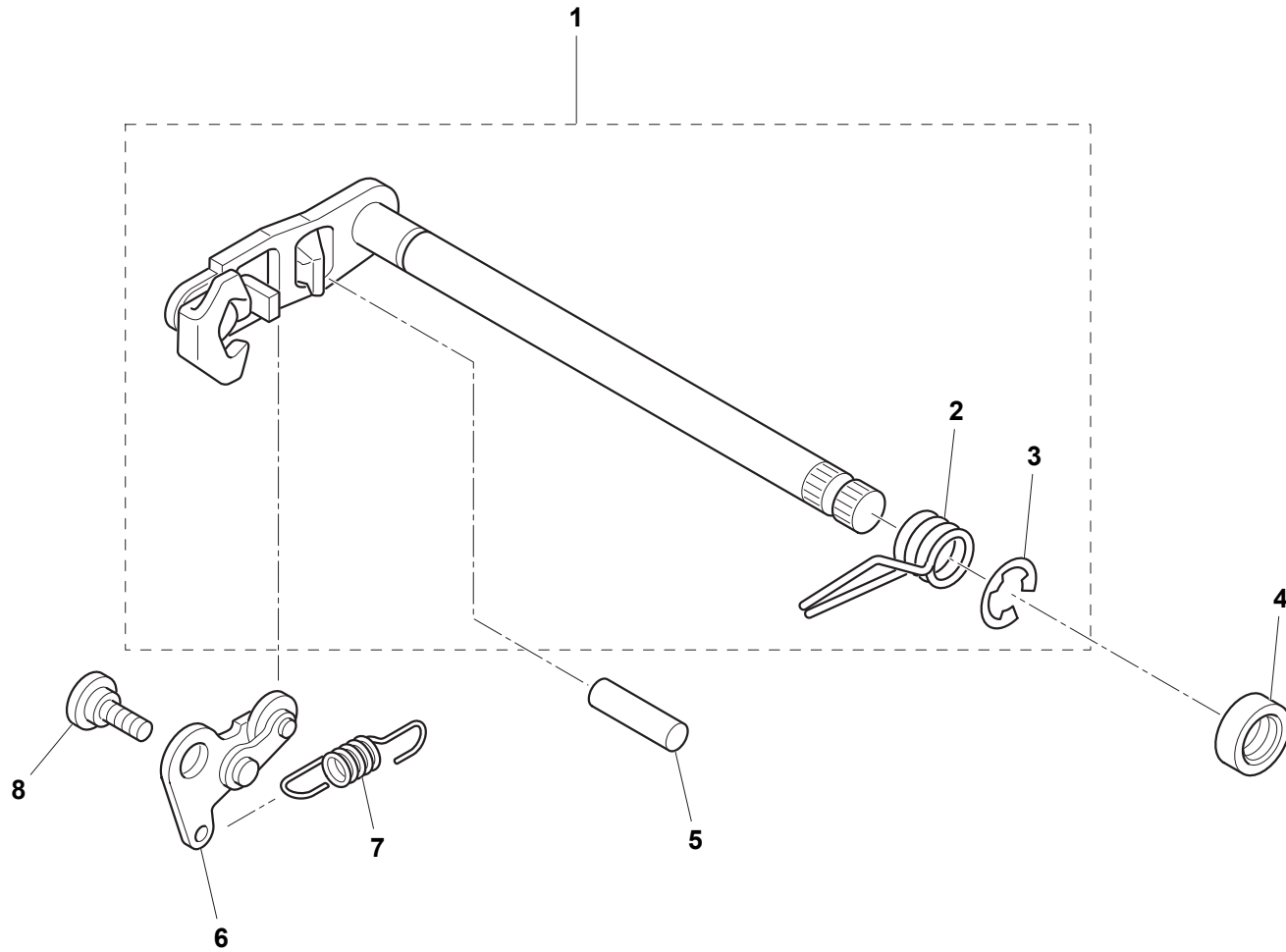



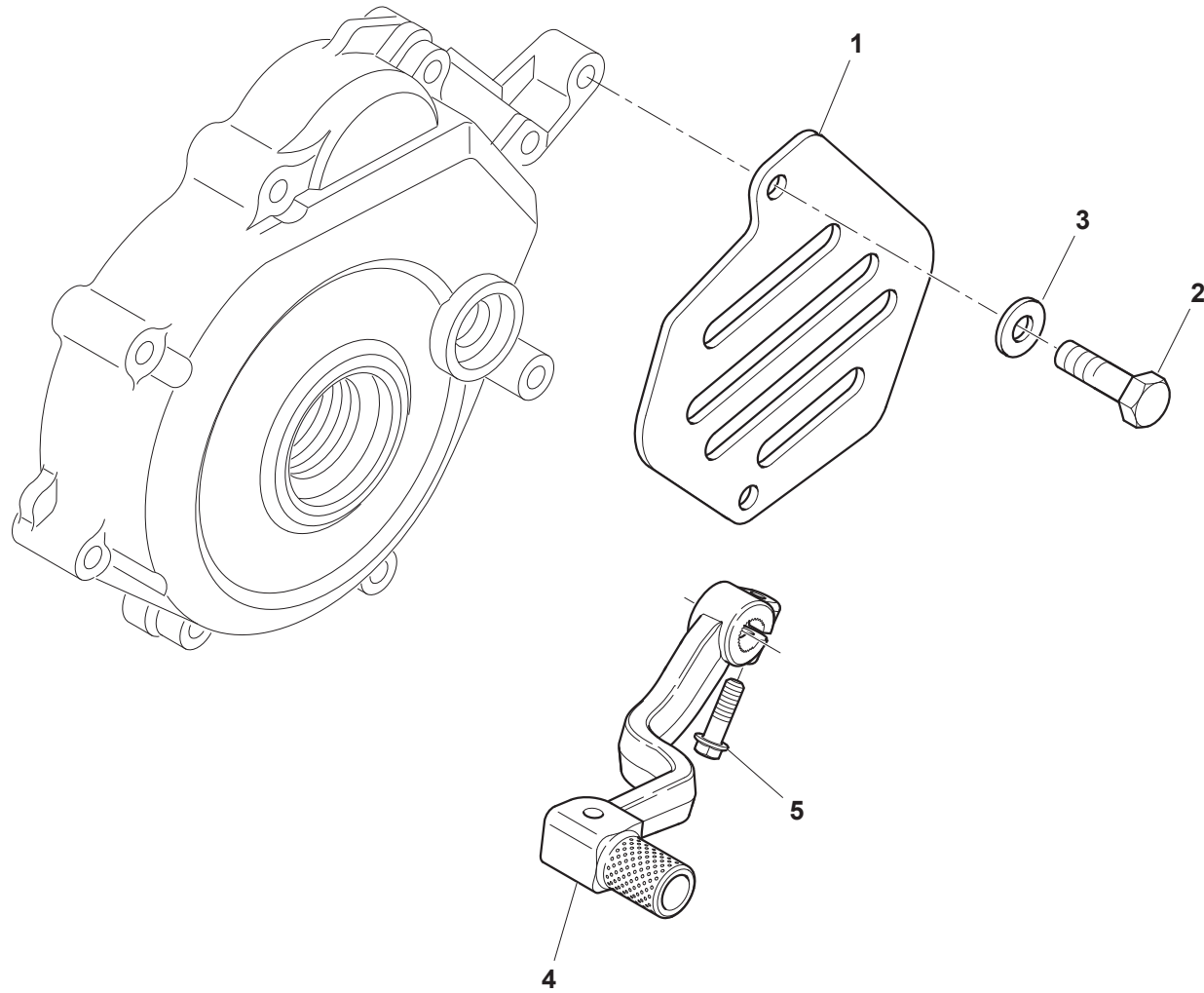





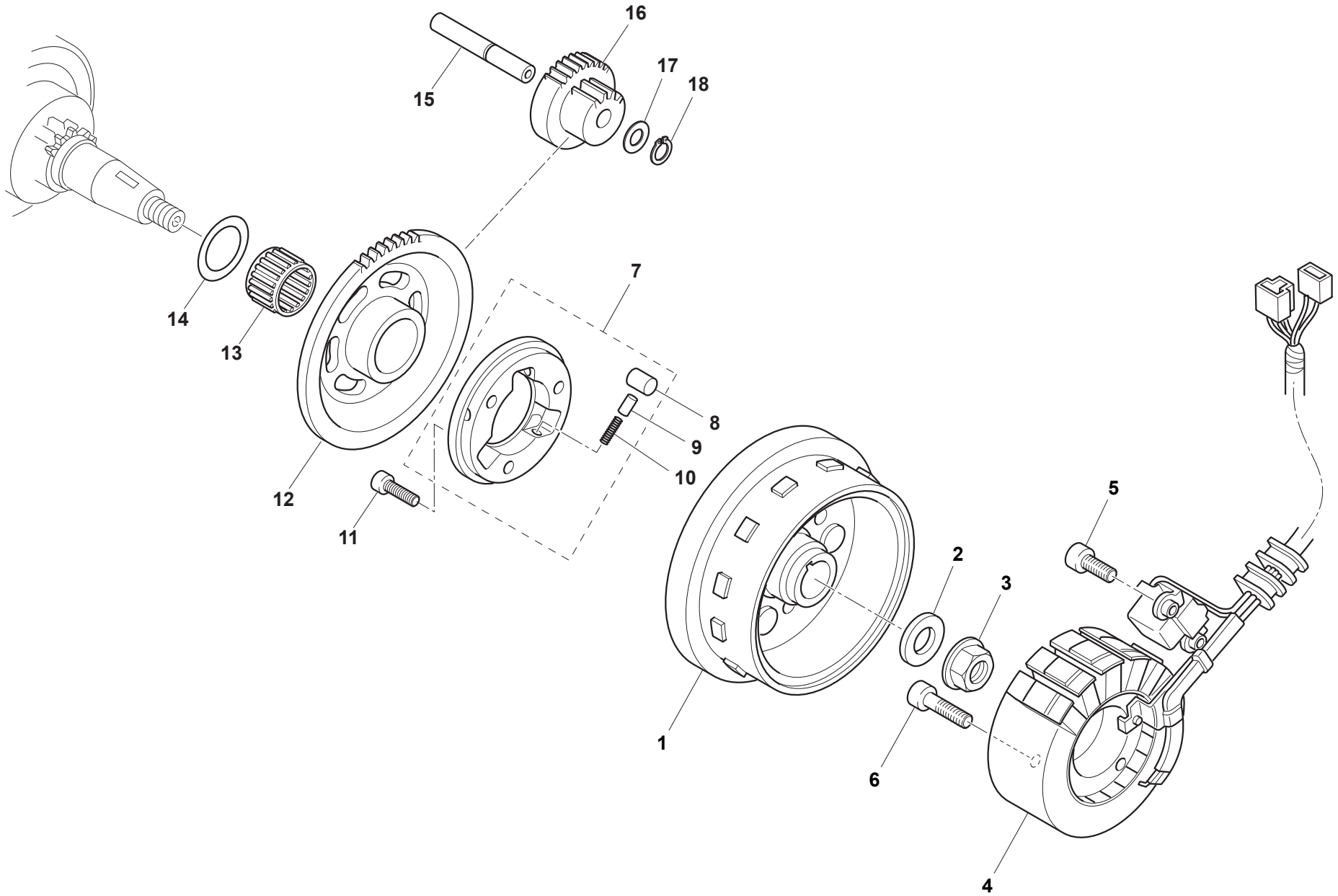



**PARTE ELETTRICA, IMPIANTO ELETTRICO 1/3 - IGNITION SYSTEM, ELECTRIC SYSTEM 1/3**  
**PARTIES ELECTRIQUE, INSTALLATION ELECTRIQUE 1/3 - ELEKTRISCHE TEILE, ELEKTRISCHE ANLAGE 1/3**  
**PARTE ELECTRICA, INSTALACION ELECTRICA 1/3**

TAVOLA  
DRAWING  
TABLE  
BILD  
TABLA

Note Notes Marke Notas	Pos. No. N. Index Pos.	N. Cod. Code No. Nr. Code Code Nr N. Cod.	Q.tà Q.ty Q.te M.ge C.ad	DENOMINAZIONE	NAME	DESIGNATION	BESHREIBUNG	DENOMINACION
	1	8000H4240	1	ROTORE GENERATORE	ROTOR, GENERATOR	ROTOR GENERATEUR	SCHWUNGRAD, STROMGENERATOR	ROTOR GENERADOR
	2	8000H4416	1	RONDELLA 12,2X30X3	WASHER 12.2X30X3	RONDELLE 12,2X30X3	SCHEIBE 12,2X30X3	ARANDELA 12,2X30X3
	3	8000H4374	1	DADO FLANGIATO M12X1,25	NUT FLANGE M12X1.25	ECROU BRIDE M12X1,25	GEFLANSCHTE MUTTER M12X1,25	TUERCA CON REBORDE M12X1,25
	4	8000H4239	1	STATORE GENERATORE	STATOR GENERATOR	STATOR GENERATEUR	STATOR, STROMGENERATOR	ESTATOR GENERADOR
	5	8000H4425	1	VITE TCCE M6X16	SCREW TCCE M6X16	VIS TCCE M6X16	SCHRAUBE TCCE M6X16	TORNILLO TCCE M6X16
	6	8000H4424	1	VITE TCCE M6X25	SCREW TCCE M6X25	VIS TCCE M6X25	SCHRAUBE TCCE M6X25	TORNILLO TCCE M6X25
	7	8000H4287	1	RUOTA LIBERA	CLUTCH, ONE WAY	ROUE LIBRE	EINWEGKUPPLUNG	EMBRAGUE, UNA VIA
	8	8000H4334	1	RULLINO	ROLLER	ROULEAU	ROLLE	RODILLO
	9	8000H4330	1	PERNO MOLLA	UPPER GUIDE	GOUJON	FEDERBOLZEN	PERNO
	10	8000H4291	1	MOLLA	SPRING	RESSORT	FEDER	MUELLE
	11	8000H4425	3	VITE TCCE M6X16	SCREW TCCE M6X16	VIS TCCE M6X16	SCHRAUBE TCCE M6X16	TORNILLO TCCE M6X16
	12	8000H4284	1	INGRANAGGIO AVVIAMENTO	GEAR, STARTER	ENGRENAGE DEMARRAGE	ZAHNRAD, STARTER	ENGRANAJE ARRANQUE
	13	8000H4304	1	ASTUCCIO A RULLI 25X30X19,8	BEARING, NEEDLE 25X30X19.8	ROULEMENT A AIGUILLES 25X30X19,8	NADELLAGER 25X30X19,8	COJINETE DE AGUJAS 25X30X19,8
	14	8000H4418	1	RONDELLA 25,2X36X1	WASHER 25.2X36X1	RONDELLE 25,2X36X1	SCHEIBE 25,2X36X1	ARANDELA 25,2X36X1
	15	8000H4329	1	PERNO INGRANAGGIO	AXLE, GEAR	AXE ENGRENAGE	ZAHNRADACHSE	EJE ENGRANAJE
	16	8000H4282	1	INGRANAGGIO INTERMEDIO	IDLER GEAR	PIGNON INTERMEDIAIRE	FREILAUFRAD	ENGRANAJE INTERMEDIO
	17	8000H4419	1	RONDELLA 10,2X18X1	WASHER 10.2X18X1	RONDELLE 10,2X18X1	SCHEIBE 10,2X18X1	ARANDELA 10,2X18X1
	18	8000H4356	1	ANELLO ELASTICO	SPRING RING	ANNEAU ARRET	SPRENGRING	ANILLO RETENCION

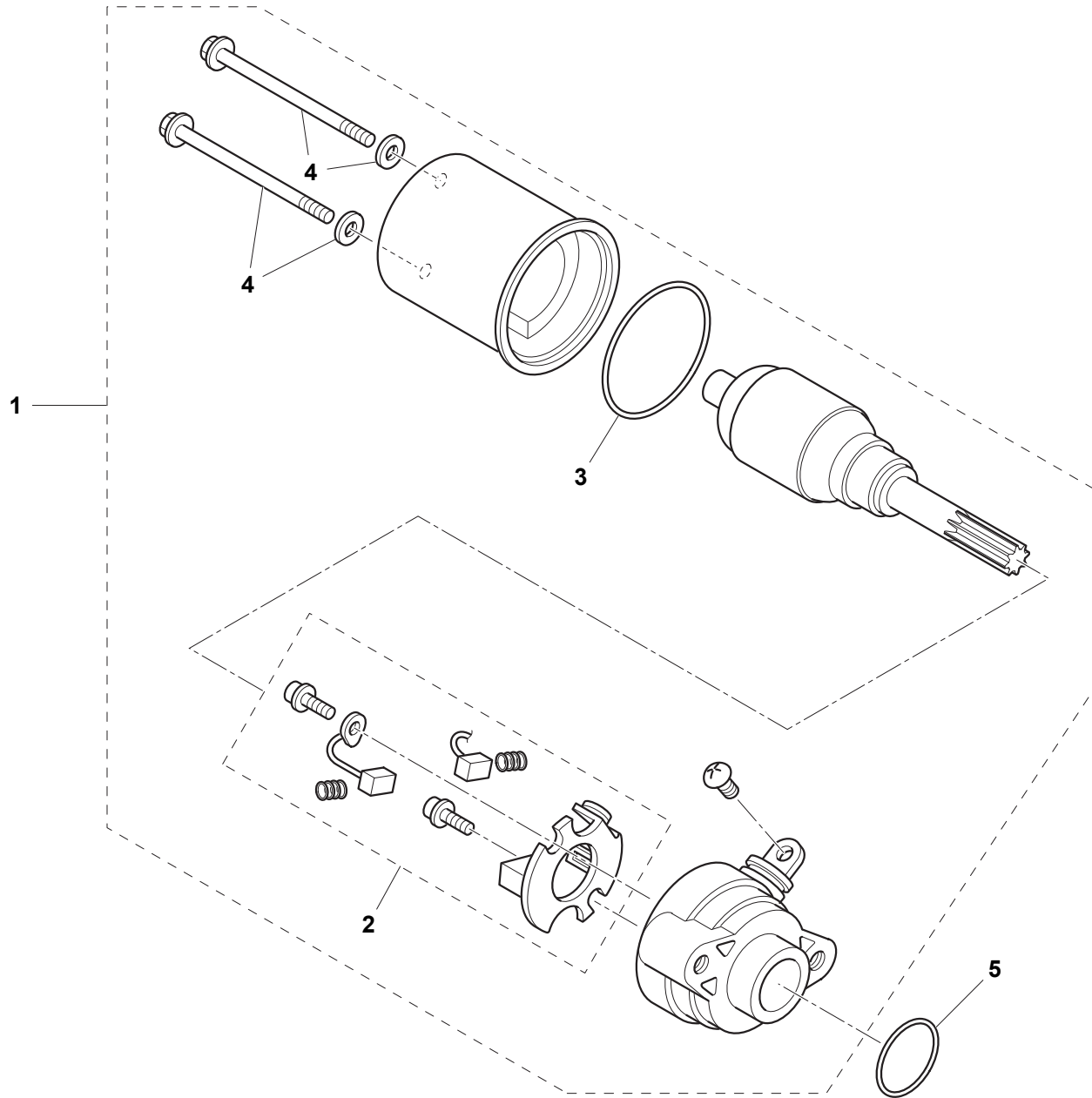



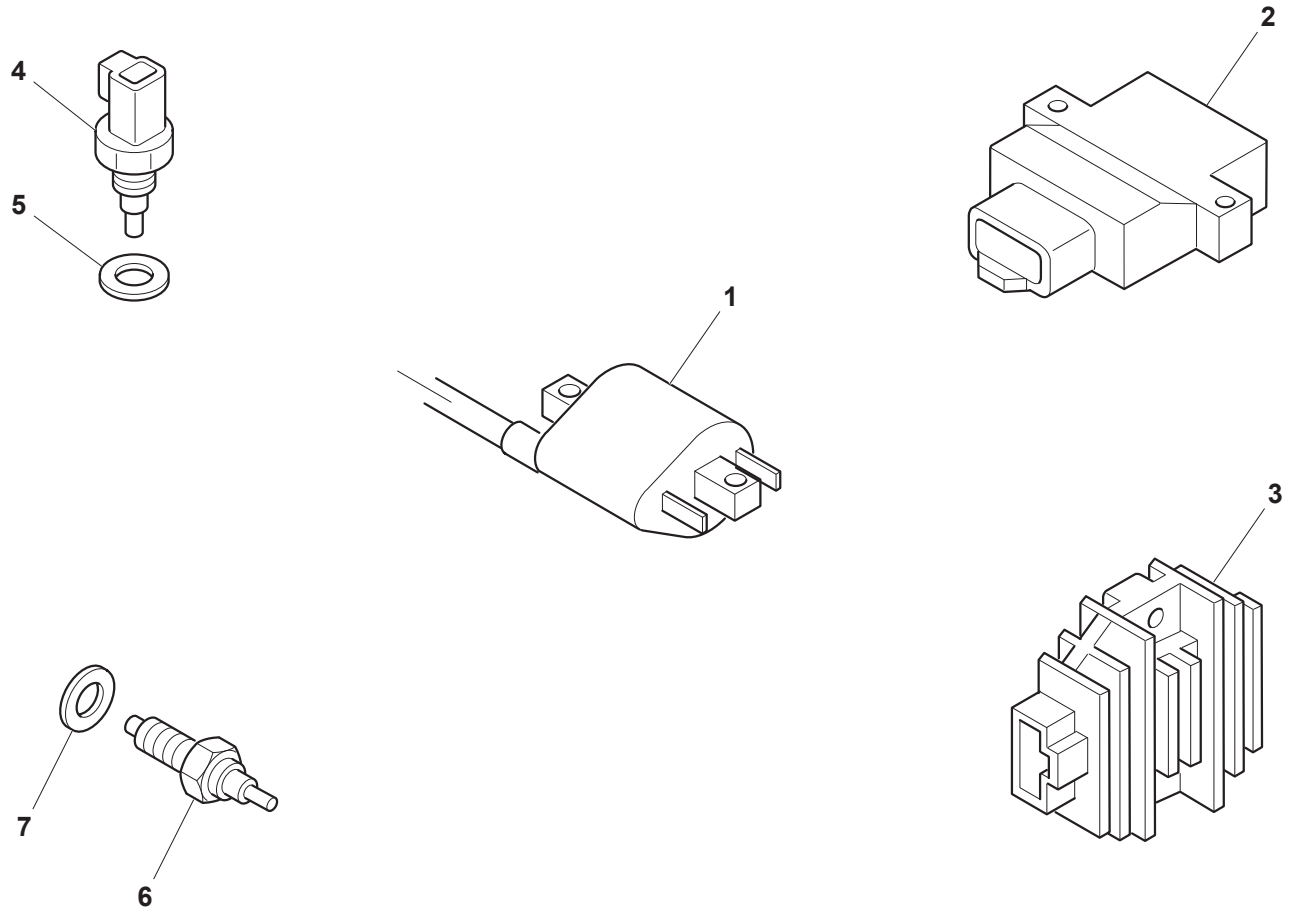



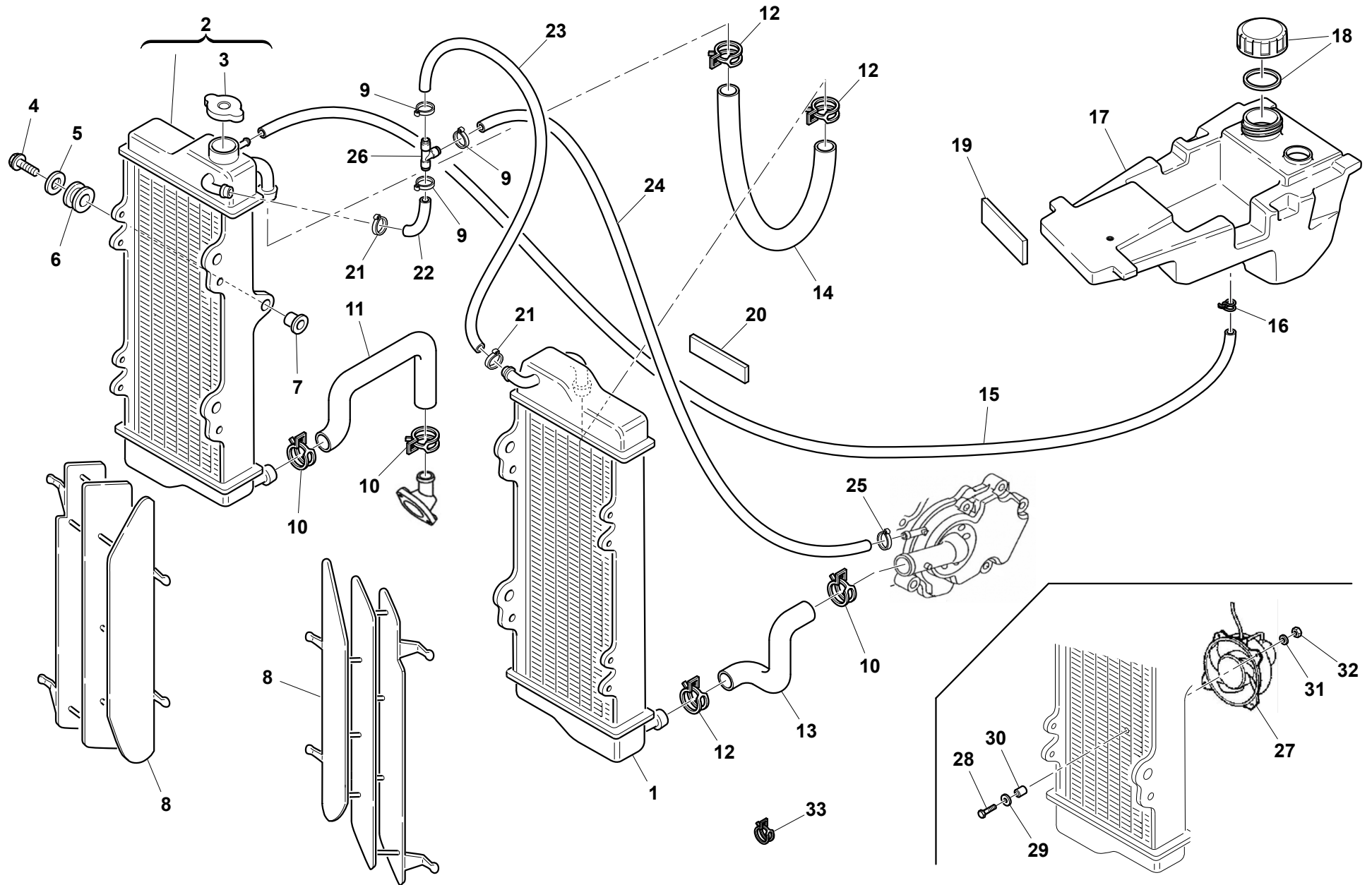



## IMPIANTO DI RAFFREDDAMENTO - COOLING SYSTEM INSTALLATION DE REFRIGERATION - SCHMIERUNGSSYSTEM EQUIPO DE ENFRIAMIENTO

Note Notes Marke Notas	Pos. No. Index Pos.	N. Cod. Code No. Nr. Code Code Nr. N. Cod.	Q.tà Q.ty Q.te M.ge C.ad	DENOMINAZIONE	NAME	DESIGNATION	BESHREIBUNG	DENOMINACION
	1	8000A7973	1	RADIATORE ACQUA SINISTRO ALEXON	WATER COOLER, LEFT ALEXON	RADIATEUR EAU GAUCHE ALEXON	LINKSWASSERKUEHLER ALEXON	RADIADOR AGUA IZQUERDO ALEXON
	2	8000H4177	1	RADIATORE ACQUA DESTRO ALEXON	WATER COOLER, RH ALEXON	RADIATEUR EAU DROIT ALEXON	RECHTSWASSERKUEHLER ALEXON	RADIADOR AGUA DERECHO ALEXON
	3	8000A7975	1	TAPPO RADIATORE ACQUA ALEXON	CAP, RADIATOR ALEXON	BOUCHON RADIATEUR ALEXON	KUEHLERPROFFEN ALEXON	TAPON RADIADOR ALEXON
	4	Z00062729	6	VITE TEF M6X1X25 CH8	SCREW TEF M6X1X25 CH8	VIS TEF M6X1X25 CH8	SCHRAUBE TEF M6X1X25 CH8	TORNILLO TEF M6X1X25 CH8
	5	Z00059801	6	RONDELLA 22X6,5X1 MM	WASHER 22X6.5X1 MM	RONDELLE 22X6,5X1 MM	SCHEIBE 22X6,5X1 MM	ARANDELA 22X6,5X1 MM
	6	800059803	6	SILENTBLOCK RADIATORE	RUBBER, RADIATOR MOUNTING	CAOUTCHOUC MONTAGE RADIATEUR	SCHWINGUNGSDAEMPFER, KUEHLER	CASQUILLO ELASTICO RADIADOR
	7	8D0059802	6	BOCCOLA 22X12X6,5	BUSH 22X12X6.5	DOUILLE 22X12X6,5	BUCHSE 22X12X6,5	CASQUILLO 22X12X6,5
	8	8AA0A0872	2	GRIGLIA RADIATORE	LOUVER, RADIATOR	GRILLE RADIATEUR	KHUELERGRILL	REJILLA RADIADOR
	9	8M0092249	3	FASCETTA CLIC R96 14,5 MM	CLAMP CLIC R96 14.5 MM	COLLIER CLIC R96 14,5 MM	KLAMMER CLIC R96 14,5 MM	ABRAZADERA CLIC R96 14,5 MM
	10	8000H3869	3	FASCETTA 23X12 MM	CLAMP 23X12 MM	COLLIER 23X12 MM	KLAMMER 23X12 MM	ABRAZADERA 23X12 MM
	11	8000H3130	1	TUBO ACQUA TERMOSTATO RADIATORE	HOSE-COOLING, THERMOSTAT-RADIATOR	TUYAU EAU THERMOSTAT RADIATEUR	WASSERSCHLAUCH THERMOSTAT KUEHLER	MANGUERA AGUA TERMOSTATO RADIADOR
	12	8000H3868	3	FASCETTA 23X12 MM	CLAMP 23X12 MM	COLLIER 23X12 MM	KLAMMER 23X12 MM	ABRAZADERA 23X12 MM
	13	8000H3131	1	TUBO RADIATORE POMPA	HOSE, COOLING.RADIATOR-PUMP	MANCHON RADIATEUR POMPE	MUFFE PUMPENKUEHLER	MANGUERA RADIADOR BOMBA
	14	8000H3673	1	TUBO COLLEGAMENTO RADIATORI	HOSE-COOLING, RADIATOR	TUYAU EAU RADIATEUR	KUEHLERSCHLAUCH	MANGUERA AGUA RADIADOR
	15	8000A1281	1	TUBO	HOSE	TUYAU	SCHLAUCH	MANGUERA
	16	800018922	1	FASCETTA ELASTICA IMA10712 10 MM	SPLIT RING IMA10712 10 MM	ANNEAU RESSORT IMA10712 10 MM	SPRENGRING IMA10712 10 MM	ABRAZADERA ELASTICA IMA10712 10 MM
	17	8000H3803	1	VASO ESPANSIONE	WATER RESERVOIR TANK	VASE EXPANSION	AUSDEHNGEFAESS	DEPOSITO EXPANSION
	18	8000H3870	1	TAPPO VASO ESPANSIONE	CAP, WATER RESERVOIR TANK	BOUCHON VASE EXPANSION	PFROPFEN, AUSDEHNGEFAESS	TAPON VASO EXPANSION
	19	800096739	1	PROTEZIONE ADESIVA	GUARD, ADHESIVE	PROTECTION ADHESIVE	KLEIBENSCHUTZ	PROTECCION ADESIVA
	20	800087072	1	ANTIVIBRANTE ADESIVO	VIBRATION DAMPER	ANTIVIBRATION	SCHWINGUNGSDAEMPFER	ANTI-VIBRACION
	21	8000H1981	3	FASCETTA 13X5 MM	CLAMP 13X5 MM	COLLIER 13X5 MM	SHELLE 13X5 MM	ABRAZADERA 13X5 MM
	22	8000H4025	1	TUBO	HOSE	TUYAU	SCHLAUCH	MANGUERA
	23	8000H3127	1	TUBO	HOSE	TUYAU	SCHLAUCH	MANGUERA
	24	8000H3128	1	TUBO	HOSE	TUYAU	SCHLAUCH	MANGUERA
	25	800056462	1	FASCETTA 11,5X6 MM	CLAMP 11.5X6 MM	COLLIER 11,5X6 MM	KLAMMER 11,5X6 MM	ABRAZADERA 11,5X6 MM
	26	8000H3129	1	RACCORDO A TRE VIE	THREE-WAYS UNION	RACCORD A TROIS VOIES	DREI-WEGE ANSCHLUSS	RACOR TRES VIAS
	27	8000A7715	1	ELETTROVENTOLA	BLOWER ASSY	ELECTRO-VENTILATEUR	ELEKTROLUEFTERRAD	ELECTROVENTILADOR
	28	8000H4031	3	VITE M4X45	SCREW M4X45	VIS M4X45	SCHRAUBE M4X45	TORNILLO M4X45
	29	62ND15547	3	RONDELLA 12X4,3X0,8	WASHER 12X4.3X0.8	RONDELLE 12X4,3X0,8	SCHEIBE 12X4,3X0,8	ARANDELA 12X4,3X0,8
	30	8000H4179	3	GUAINA	SHEATH	GAINE	HUELLE	FORRO
	31	ZA0020373	3	RONDELLA 18X4,3X1,5	WASHER 18X4.3X1.5	RONDELLE 18X4,3X1,5	SCHEIBE 18X4,3X1,5	ARANDELA 18X4,3X1,5
	32	Z00091033	3	DADO AUTOBLOCCANTE M4	NUT, SELF LOCKING M4	ECROU AUTOBLOQUANT M4	SELBSTSPERRENDE MUTTER M4	TUERCA AUTOBLOQUEANTE M4
	33	80A042349	2	FASCETTA	CLAMP	COLLIER	KLAMMER	ABRAZADERA

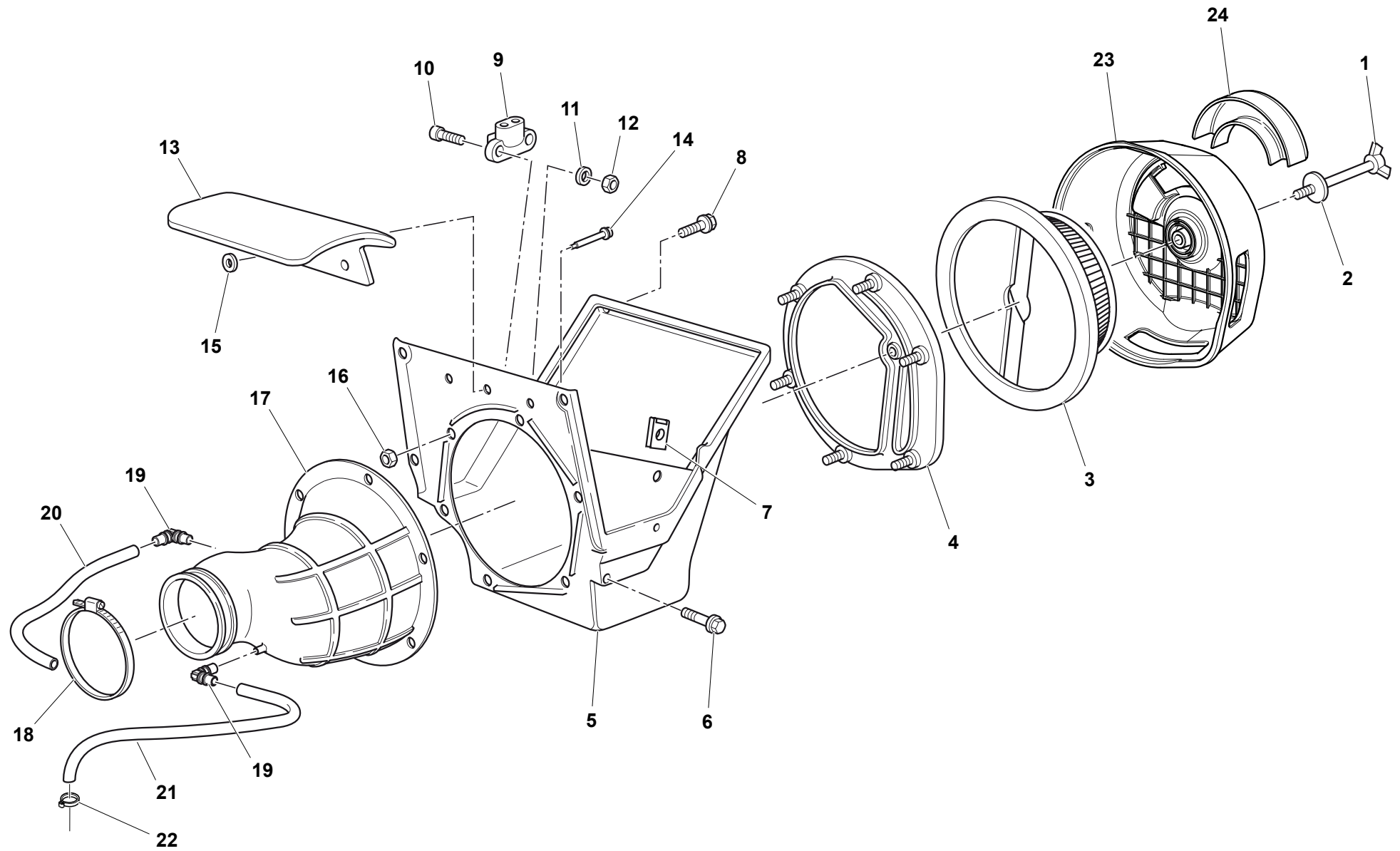

**FILTRO ARIA - AIR FILTER**  
**FILTRE AIRE - LUFTFILTER**  
**FILTRO DE AIRE**

Note Notes Marke Notas	Pos. No. N. Index Pos.	N. Cod. Code No. Nr. Code Code Nr N. Cod.	Q.tà Q.ty Q.te M.ge C.ad	DENOMINAZIONE	NAME	DESIGNATION	BESHREIBUNG	DENOMINACION
	1	ZA0037947	1	VITE A FARFALLA M6X1	SCREW, WING M6X1	VIS A OREILLES M6X1	FLUEGELSCHRAUBE M6X1	TORNILLO MARIPOSA M6X1
	2	62ND15549	1	RONDELLA 18X6,4X1 MM	WASHER 18X6.4X1 MM	RONDELLE 18X6,4X1 MM	SCHEIBE 18X6,4X1 MM	ARANDELA 18X6,4X1 MM
	3	8000H3134	1	FILTRO ARIA	FILTER, AIR	FILTRE A AIR	LUFTFILTER	FILTRO AIRE
	4	8000H3013	1	FLANGIA	FLANGE	BRIDE	FLANSCH	BRIDA
	5	800091792	1	CASSETTA FILTRO ARIA	CASE, AIR CLEANER	BOITE FILTRE A AIR	LUFTFILTERGEHAUSE	CAJA FILTRO AIRE
	6	Z00062725	2	VITE TEF M6X1X10 CH8	SCREW TEF M6X1.00X10 CH8	VIS TEF M6X1,00X10 CH8	SCHRAUBE TEF M6X1,00X10 CH8	TORNILLO TEF M6X1,00X10 CH8
	7	U00055134	2	DADO ELASTICO M5X0,8	NUT M5X0.8	ECROU M5X0,8	MUTTER M5X0,8	TUERCA M5X0,8
	8	8B00A8423	2	VITE FLANGIATA M6X16	BOLT FLANGE M6X16	VIS A EMBASE M6X16	GEFLANSCHSCHRAUBE M6X16	TORNILLO CON VALONA M6X16
	9	55240121A	1	SENSORE TEMPERATURA ARIA	SENSOR, AIR TEMPERATURE	CAPTEUR TEMPERATURE AIR	LUFTTEMPERATURFUEHLER	SENSOR TEMPERATURA AIRE
	10	60ND07305	2	VITE TCEI M3X12	SCREW TCEI M3X12	VIS TCEI M3X12	SCHRAUBE TCEI M3X12	TORNILLO TCEI M3X12
	11	62ND15516	2	RONDELLA	WASHER	RONDELLE	SCHEIBE	ARANDELA
	12	Z00048411	2	DADO AUTOBLOCCANTE M3	NUT, SELF LOCKING M3	ECROU AUTOBLOQUANT M3	SELBSTSPERRENDE MUTTER M3	TUERCA AUTOBLOQUEANTE M3
	13	800094625	1	PROTEZIONE CASSETTA FILTRO	GUARD, AIR CLEANER CASE	PROTECTION BOITE FILTRE A AIR	SCHUTZ, LUFTFILTERGEHAUSE	GOMA PROTECCION CAJA FILTRO
	14	800033372	3	RIVETTO A STRAPPO 3,8X8	RIVET, BLIND 3.8X8	RIVET 3,8X8	NIETE 3,8X8	REMACHE CIEGO 3,8X8
	15	62ND15547	3	RONDELLA 12X4,3X0,8	WASHER 12X4.3X0.8	RONDELLE 12X4,3X0,8	SCHEIBE 12X4,3X0,8	ARANDELA 12X4,3X0,8
	16	Z00040718	6	DADO AUTOBLOCCANTE M5X0,8	NUT, SELF LOCKING M5X0.8	ECROU AUTOBLOQUANT M5X0,8	SELBSTSPERRENDE MUTTER M5X0,8	TUERCA AUTOBLOQUEANTE M5X0,8
	17	8000H3077	1	COLLETTORE ASPIRAZIONE	MANIFOLD, INTAKE	COLLECTEUR ADMISSION	EINSATZ KRUEMMER	COLECTOR ADMISION
	18	8G0099475	1	FASCETTA NEMO 30/60 MM	CLAMP NEMO 30/60 MM	COLLIER NEMO 30/60 MM	SHELLE NEMO 30/60 MM	ABRAZADERA NEMO 30/60 MM
	19	8000H3517	2	RACCORDO TUBO	JOINT, HOSE	RACCORD TUYAU	ANSCHLUSS, SCHLAUCH	RACOR MANGUERA
	20	8000H3518	1	TUBO	HOSE	TUYAU	SCHLAUCH	MANGUERA
	21	8000H3519	1	TUBO	HOSE	TUYAU	SCHLAUCH	MANGUERA
	22	8M0092249	1	FASCETTA CLIC R96 14,5 MM	CLAMP CLIC R96 14.5 MM	COLLIER CLIC R96 14,5 MM	KLAMMER CLIC R96 14,5 MM	ABRAZADERA CLIC R96 14,5 MM
	23	8000H4136	1	COPERCHIO FILTRO ARIA	CAP, AIR CLEANER	COUVERCLE FILTRE AIR	LUFTFILTERDECKEL	CUBIERTA FILTRO AIRE
	24	8000H4137	1	COPERCHIO	COVER	COUVERCLE	DECKEL	CUBIERTA

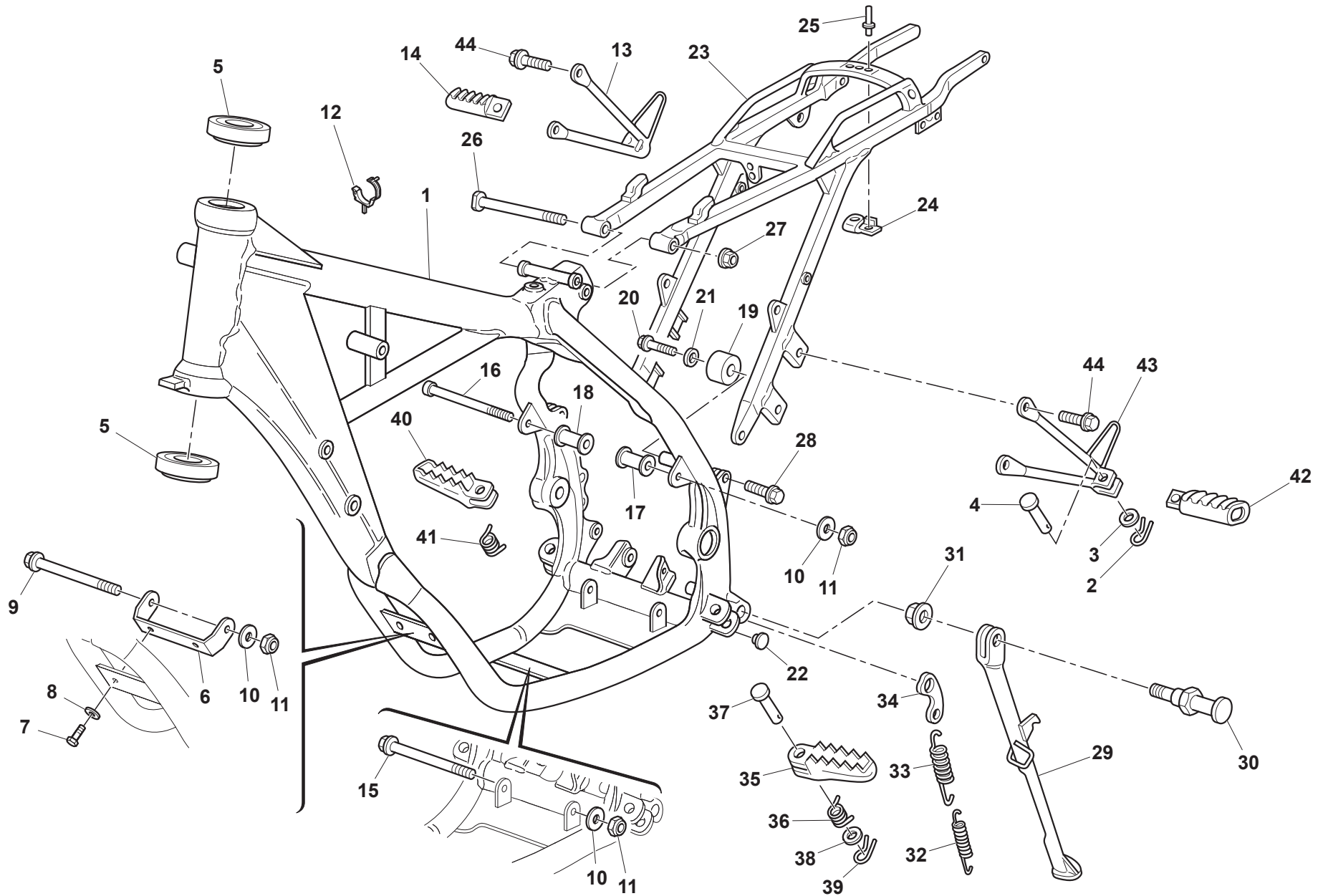

**TELAIO, PEDANE - FRAME, FOOT RESTS  
CADRE, REPOSE PIEDS - RAHMEN, FUSSBRETT  
BASTIDOR, REPOSAPIES**

Note Notes Marke Notas	Pos. No. N. Index Pos.	N. Cod. Code No. Nr. Code Code Nr N. Cod.	Q.tà Q.ty Q.te M.ge C.ad	DENOMINAZIONE	NAME	DESIGNATION	BESHREIBUNG	DENOMINACION
	1	8000H3105	1	TELAIO	FRAME	CADRE	RAHMEN	BASTIDOR
	2	64ND20048	2	COPIGLIA 1,3X12	PIN, COTTER 1.3X12	GOUPILLE, FENDUE 1,3X12	SPLINT 1,3X12	GRUPILLA 1,3X12
	3	62ND15504	2	RONDELLA 12X6,4X1	WASHER 12X6.4X1	RONDELLE 12X6,4X1	SCHEIBE 12X6,4X1	ARANDELA 12X6,4X1
	4	800041459	2	PERNO PEDANA	PIN, FOOTREST	PIVOT REPOSE-PIEDS	BOLZEN, FUSSREST	PERNO ESTRIBO
	5	800087243	2	CUSCINETTO A RULLI CONICI 29-48-17,5	CONICAL ROLLERS BEARING 29-48-17.5	ROULEMENT A ROULEAUX CONIQUES 29-48-17,5	KEGELROLLENLAGER 29-48-17,5	COJINETE DE RODILLOS CONICO 29-48-17,5
	6	8000H3141	1	SUPPORTO MOTORE ANTERIORE	BRACKET-ENGINE, FRONT	SUPPORT MOTEUR AVANT	MOTORKONSOLE, VORNE	SOPORTE MOTOR DELANTERO
	7	Z00062727	2	VITE TE M6X1X16 CH8	SCREW TE M6X1X16 CH8	VIS TE M6X1X16 CH8	SCHRAUBE TE M6X1X16 CH8	TORNILLO TE M6X1X16 CH8
	8	Z00056359	2	RONDELLA 16X6,4X1,5	WASHER 16X6.4X1.5	RONDELLE 16X6,4X1,5	SCHEIBE 16X6,4X1,5	ARANDELA 16X6,4X1,5
	9	8A00H3738	1	VITE TE M10X120	SCREW TE M10X120	VIS TE M10X120	SCHRAUBE TE M10X120	TORNILLO TE M10X120
	10	8000H1412	3	RONDELLA 10,5X25X2 MM	WASHER 10.5X25X2 MM	RONDELLE 10,5X25X2 MM	SCHEIBE 10,5X25X2 MM	ARANDELA 10,5X25X2 MM
	11	Z00042022	3	DADO M10X1,25 H10 CH14	NUT M10X1.25 H10 CH14	ECROU M10X1,25 H10 CH14	MUTTER M10X1,25 H10 CH14	TUERCA M10X1,25 H10 CH14
	12	800058207	1	FASCETTA FERMACAPO 15 MM	GUIDE, CABLE 15 MM	PASSE-CABLE 15 MM	KABELDURCHGANG 15 MM	PASACABLES 15 MM
	13	8000H4165	1	SUPPORTO PEDANA POSTERIORE DESTRA	BRACKET, PILLION FOOTREST RH	SUPPORT REPOSE-PIEDS ARRIERE DROIT	HINTERFUSSRASTENHALTER RECHTS	SOPORTE ESTRIBO TRASERO DERECHO
	14	800066652	1	PEDANA POSTERIORE DESTRA	FOOTREST, REAR RH	REPOSE-PIEDS ARRIERE DROIT	FUSSRASTE HINTEN , RECHTS	ESTRIBO TRASERO DERECHO
	15	8B00H3738	1	VITE TE M10X110	SCREW TE M10X110	VIS TE M10X110	SCHRAUBE TE M10X110	TORNILLO TE M10X110
	16	8000H3738	1	VITE TCEI M10X245	SCREW TCEI M10X245	VIS TCEI M10X245	SCHRAUBE TCEI M10X245	TORNILLO TCEI M10X245
	17	8000H3737	1	DISTANZIALE SINISTRO	SPACER, LH	ENTRETOISE GAUCHE	ABSTANDHALTER LINKS	DISTANCIADOR IZQUERDO
	18	8000H3736	1	DISTANZIALE DESTRO	SPACER, RH	ENTRETOISE DROIT	ABSTANDHALTER RECHTS	DISTANCIADOR DERECHO
	19	800056800	2	RULLO TENDICATENA	ROLLER, CHAIN TENSIONER	ROULEAU, TENDEUR CHAINE	ROLLE, KETTENSPIANNER	RODILLO, TENSIONADOR CADENA
	20	Z00062725	2	VITE TEF M6X1X10 CH8	SCREW TEF M6X1.00X10 CH8	VIS TEF M6X1,00X10 CH8	SCHRAUBE TEF M6X1,00X10 CH8	TORNILLO TEF M6X1,00X10 CH8
	21	Z00030319	2	RONDELLA 20X6,4X2,5	WASHER 20X6.4X2.5	RONDELLE 20X6,4X2,5	SCHEIBE 20X6,4X2,5	ARANDELA 20X6,4X2,5
	22	8000H3511	2	TAPPO	PLUG	BOUCHON	VERSCHLUSS	TAPON
	23	8010H2395	1	TELAIO POSTERIORE	REAR FRAME	CADRE ARRIERE	HINTERER RAHMEN	BASTIDOR TRASERO
	24	800069150	1	PIASTRINA ATTACCO SELLA	BRACKET, SEAT	SUPPORT SELLE	KONSOLE, SITZBANK	SOPORTE ASIENITO
	25	800033373	1	RIVETTO A STRAPPO 3,3X14	SHEAR RIVET 3.3X14	RIVET ARRACHAGE 3,3X14	REISSNIETE 3,3X14	REMACHE A DESGARRE 3,3X14
	26	Z00061357	1	VITE TE M8X1,25X105	SCREW TE M8X1.25X105	VIS TE M8X1,25X105	SCHRAUBE TE M8X1,25X105	TORNILLO TE M8X1,25X105
	27	Z00043928	1	DADO M8X1,25	NUT M8X1.25	ECROU M8X1,25	MUTTER M8X1,25	TUERCA M8X1,25
	28	Z00069056	2	VITE TEF M8X1,25X20 CH12	SCREW TEF M8X1.25X20 CH12	VIS TEF M8X1,25X20 CH12	SCHRAUBE TEF M8X1,25X20 CH12	TORNILLO TEF M8X1,25X20 CH12
SMS125/11	29	8BC095638	1	CAVALLETTO LATERALE	STAND, SIDE	BEQUILLE LATERALE	KIPPSTAENDER	CABALLETE LATERAL
TE125/11	29	8CC095638	1	CAVALLETTO LATERALE	STAND, SIDE	BEQUILLE LATERALE	KIPPSTAENDER	CABALLETE LATERAL
	30	8A0097976	1	VITE CAVALLETTO LATERALE	SCREW SIDE STAND PIVOT	VIS FIXATION BEQUILLE	STAENDERSCHRAUBE	TORNILLO FIJACION CABALLETE
	31	Z00043928	1	DADO M8X1,25	NUT M8X1.25	ECROU M8X1,25	MUTTER M8X1,25	TUERCA M8X1,25
	32	800062676	1	MOLLA CAVALLETTO LATERALE INTERNA	SPRING, SIDE STAND INNER	RESSORT INTERIEUR BEQUILLE LATERAL	INNEREFEDER, KIPPSTAENDERFEDER	MUELLE INTERIOR CABALLETE LATERAL







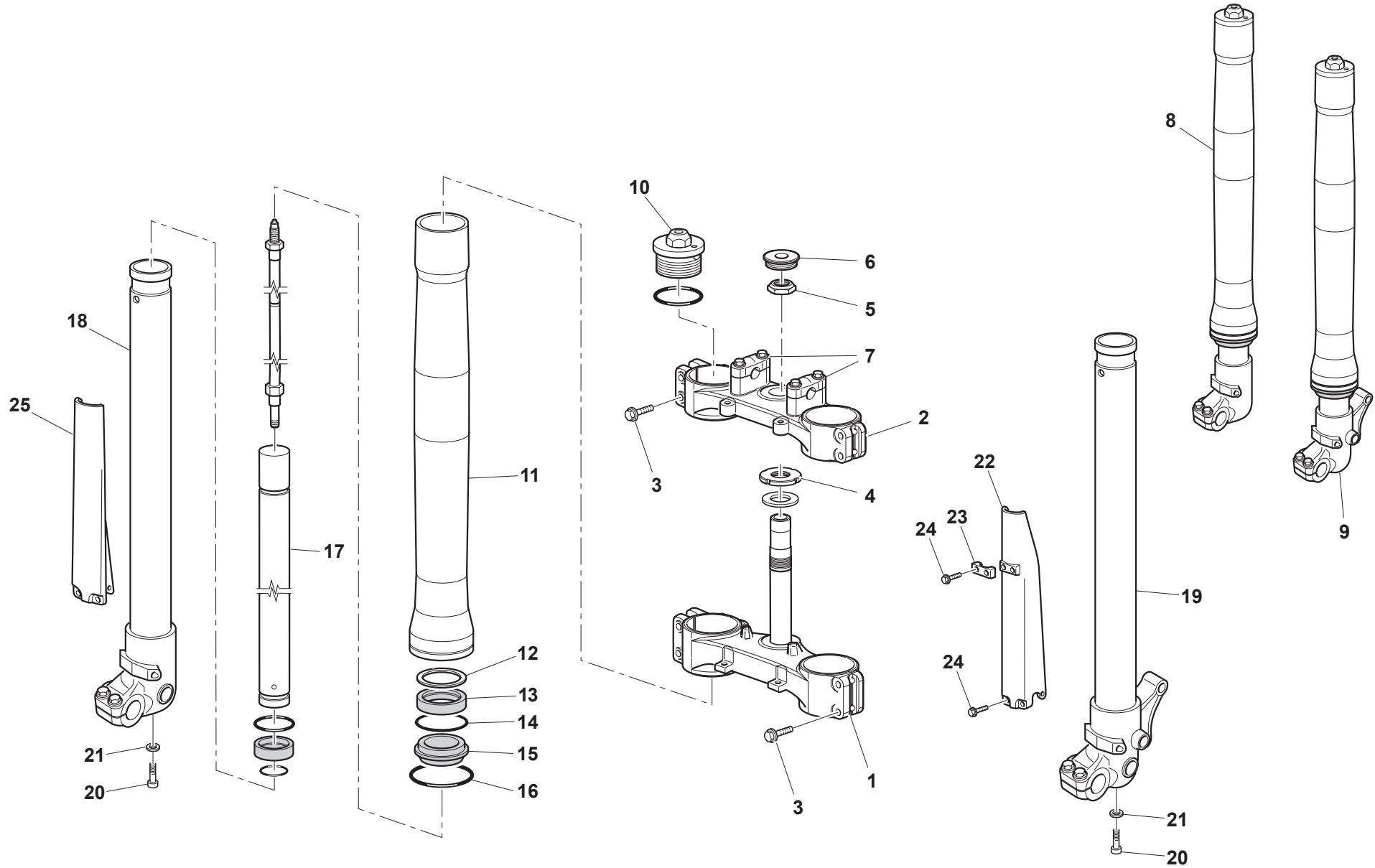



**SOSPENSIONE ANTERIORE - FRONT FORK ASSEMBLY**  
**SUSPENSION AVANT - VORDERTELESKOPGABEL**  
**SUSPENSION DELANTERA**

Note Notes Marke Notas	Pos. No. N. Index Pos.	N. Cod. Code No. Nr. Code Code Nr N. Cod.	Q.tà Q.ty Q.te M.ge C.ad	DENOMINAZIONE	NAME	DESIGNATION	BESHREIBUNG	DENOMINACION
SMS-TE	1	8000H4487	1	PIASTRA FORCELLA INFERIORE	STEM, STEERING	SOCLE DIRECTION	GABELBRUECKE, UNTEN	BASE DIRECCION
SMS-TE	2	8000H4488	1	PIASTRA FORCELLA SUPERIORE	HEAD, STEERING STEM	TETE DIRECTION	GABELKOPF	TIJA SUPERIOR
SMS-TE	3	8000H2299	12	VITE M8X40 DIN6921	SCREW M8X40 DIN6921	VIS M8X40 DIN6921	SCHRAUBE M8X40 DIN6921	TORNILLO M8X40 DIN6921
SMS-TE	4	8000H4493	1	GHIERA STERZO M28X1	THREAD, STEERING HEAD TOP M28X1	ECROU SUPERIEUR TETE DIRECTION M28X1	OBER-GEWINDE, STEUERKOPF M28X1	TUERCA, SUPERIOR CABEZAL DIRECCION M28X1
SMS-TE	5	8000H4494	1	DADO CANNOTTO STERZO M26X1	NUT, STEERING STEM M26X1	ECROU TIGE DIRECTION M26X1	MUTTER, STEUERKOPFSCHAFT M26X1	TUERCA, VARILLA DIRECCION M26X1
SMS-TE	6	8000H4495	1	TAPPO	PLUG	BOUCHON	VERSCHLUSS	TAPON
SMS-TE	7	8000H2317	2	CAVALLOTTO MANUBRIO SUPERIORE	HANDLEBAR BRACKET, UPPER	BRIDE GUIDON, SUPERIEURE	LENKER BUEGELBOLZEN, OBERE	PUENTE MANILLAR, SUPERIOR
SMS-TE	8	8000H4477	1	GAMBA FORCELLA DESTRA	FRONT CUSHION ASSY RH	JAMBE FOURCHE DROIT	GABELBEIN, RECHTS	PIERNA HORQUILLA DERECHA
SMS-TE	9	8000H4478	1	GAMBA FORCELLA SINISTRA	FRONT CUSHION ASSY LH	JAMBE FOURCHE GAUCHE	GABELBEIN, LINKS	PIERNA HORQUILLA IZQUERDA
SMS-TE	10	8000H2305	2	TAPPO FORCELLA	CAP, FRONT FORK	BOUCHON FOURCHE	VERSCHLUSS GABEL	TAPON HORQUILLA
SMS-TE	11	8000H2307	2	FODERO FORCELLA	FORK OUTER TUBE	FOURREAU FOURCHE	GABEL HUELSE	FUNDA HORQUILLA
SMS-TE	12	8000H2308	2	RONDELLA 52,4X41,5X2	WASHER 52.4X41.5X2	RONDELLE 52,4X41,5X2	SCHEIBE 52,4X41,5X2	ARANDELA 52,4X41,5X2
SMS-TE	13	8000H2309	2	PARAOLIO FORCELLA	SEAL OIL, FORK	BAGUE D'ETANCHEITE, FOURCHE	GABELDICHRING	RETEN ACEITE, HORQUILLA
SMS-TE	14	8000H4742	2	ANELLO RITEGNO PARAOLIO	RETAINING RING	JONC MAINTIEN	SCHLIESSRING	ANILLO RETEN
SMS-TE	15	8000H2311	2	PARAPOLVERE FORCELLA	SEAL, DUST FRONT FORK	COIFFE CACHE-POUSSIÈRE FOURCHE	STAUBSCHUTZHAUBE, GABEL	CAPUCHON GUARDAPOLVO HORQUILLA
SMS-TE	16	8000H2312	2	ANELLO DI PROTEZIONE	RING	ANNEAU	RING	ANILLO
SMS-TE	17	8000H2304	2	CARTUCCIA IDRAULICA	CARTRIDGE, FRONT FORK	CARTOUCHE FOURCHE	GABELDAEMPFER	CARTUCHO HORQUILLA
SMS-TE	18	8000H2313	1	STELO FORCELLA DESTRO	FORK INNER TUBE RH	TIGE FOURCHE DROITE	GABELSTANGE, RECHTS	MANGUITO HORQUILLA DERECHO
SMS-TE	19	8000H2314	1	STELO FORCELLA SINISTRO	FORK INNER TUBE LH	TIGE FOURCHE GAUCHE	GABELSTANGE, LINKS	MANGUITO HORQUILLA IZQUERDO
SMS-TE	20	8000H2301	2	VITE TCCE M10X40	SCREW TCCE M10X40	VIS TCCE M10X40	SCHRAUBE TCCE M10X40	TORNILLO TCCE M10X40
SMS-TE	21	8000H2303	2	RONDELLA IN RAME 16X10,2X1,5	WASHER, COPPER 16X10.2X1.5	RONDELLE EN CUIVRE 16X10,2X1,5	KUPFERSCHEIBE 16X10,2X1,5	ARANDELA COBRE 16X10,2X1,5
SMS-TE	22	80A0A8481	1	PROTEZIONE STELO FORCELLA SINISTRO	GUARD FORK TUBE, LH	PROTECTION TIGE FOURCHE GAUCHE	GABELSTANGENSCHUTZ LINKS	PROTECCION VARILLA IZQUERDA
SMS-TE	23	80A0A0633	1	FERMACAVO	CLAMP, WIRE	COLLIER, CORDON	KABELKLEMME	GRAMPA CORDON
SMS-TE	24	8000A8423	6	VITE FLANGIATA M6X8	BOLT, FLANGE M6X8	VIS A EMBASE M6X8	GEFLANSCHSCHRAUBE M6X8	TORNILLO CON VALONA M6X8
SMS-TE	25	80A0A8482	1	PROTEZIONE STELO FORCELLA DESTRO	GUARD FORK TUBE, RH	PROTECTION TIGE FOURCHE DROITE	GABELSTANGENSCHUTZ RECHTS	PROTECCION VARILLA DERECHA
SMS		ZKHA500ABBV000353		Fino alla matricola	Until serial number	Jusqu'au matricule	Bis zu Matrikel	Hasta la matricula
TE		ZKHA500AABV000172		Fino alla matricola	Until serial number	Jusqu'au matricule	Bis zu Matrikel	Hasta la matricula

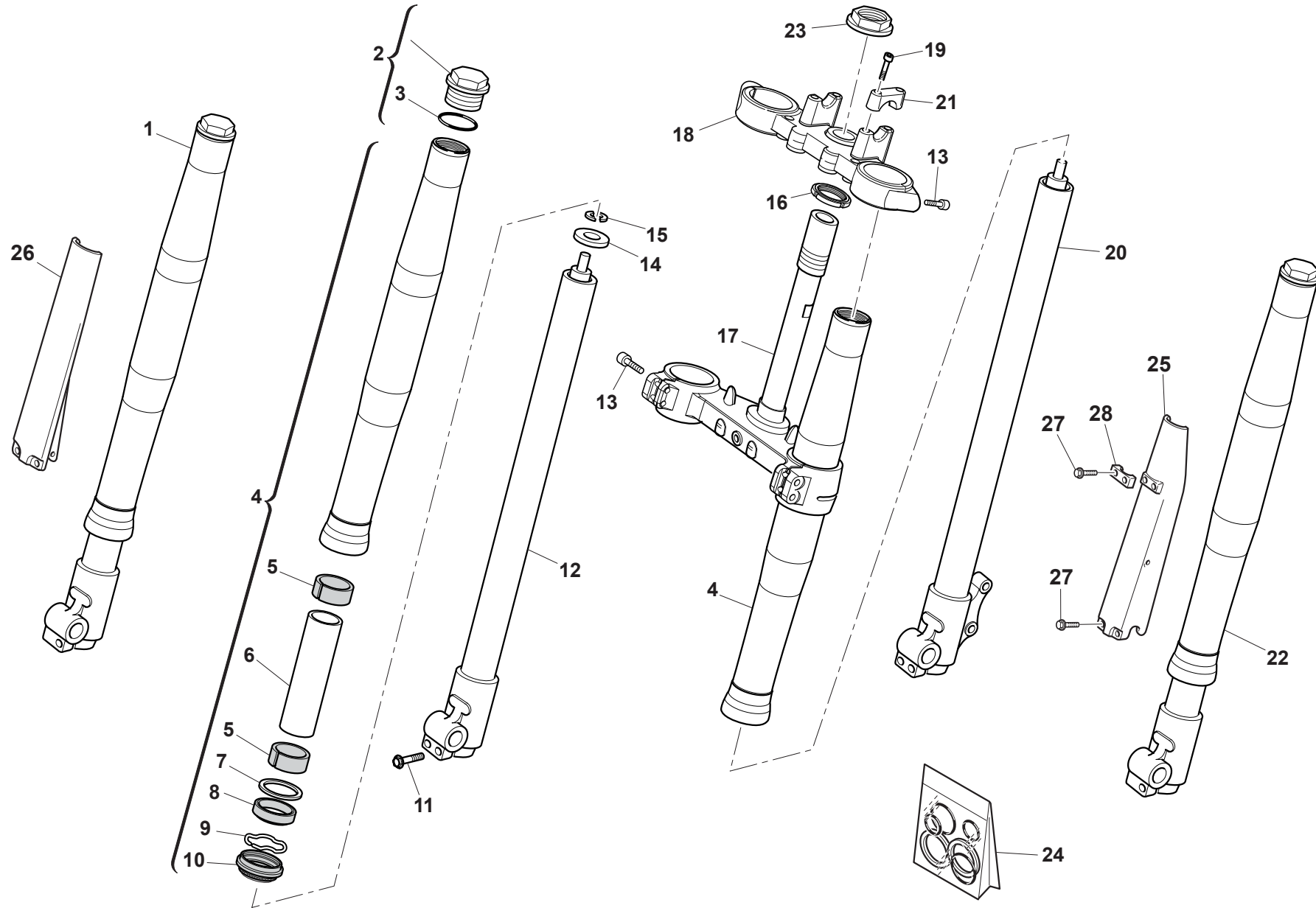



# TE-SMS4 125/2011

**SOSPENSIONE ANTERIORE - FRONT FORK ASSEMBLY**  
**SUSPENSION AVANT - VORDERTELESKOPGABEL**  
**SUSPENSION DELANTERA**

TAVOLA  
DRAWING  
TABLE  
BILD  
TABLA

# 22A

Note Notes Marke Notas	Pos. No. Index Pos.	N. Cod. Code No. Nr. Code Code Nr N. Cod.	Q.tà Q.ty Q.te M.ge C.ad	DENOMINAZIONE	NAME	DESIGNATION	BESHREIBUNG	DENOMINACION
SMS-TE	1	8000H5759	1	GAMBA FORCELLA DESTRA	FRONT CUSHION ASSY RIGHT	JAMBE FOURCHE DROITE	GABELBEIN, RECHTS	PIERNA HORQUILLA DERECHA
SMS-TE	2	800077362	2	TAPPO FODERO FORCELLA	CAP, FRONT FORK	BOUCHON FOURREAU FOURCHE	VERSCHLUSS, HUELSE	TAPON FUNDA HORQUILLA
SMS-TE	3	800077360	2	ANELLO O-RING	O-RING	JOINT TORIQUE	O-RING	JUNTA TORICA
SMS-TE	4	8000H5761	2	FODERO FORCELLA	FORK OUTER TUBE	FOURREAU FOURCHE	GABEL HUELSE	FUNDA HORQUILLA
SMS-TE	5	800070966	4	BOCCOLA INFERIORE	BUSH, LOWER	DOUILLE INFERIEUR	UNTERE BUCHSE	CASQUILLO INFERIOR
SMS-TE	6	800079005	2	TUBETTO PRECARICA	PRE-LOAD SLEEVE	TUYAU PRE-CHARGE	VORBELASTUNGSROHR	TUBO PRE-CARGA
SMS-TE	7	800077378	2	ANELLO O-RING	O-RING	JOINT TORIQUE	O-RING	JUNTA TORICA
SMS-TE	8	800037977	2	PARAOLIO FORCELLA	SEAL OIL, FORK	BAGUE D'ETANCHEITE, FOURCHE	GABELDICHRING	RETEN ACEITE, HORQUILLA
SMS-TE	9	800055520	2	ANELLO ELASTICO	SPRING RING	ANNEAU ARRET	SPRENGRING	ANILLO RETENCION
SMS-TE	10	800087038	2	PARAPOLVERE FORCELLA	SEAL, DUST FRONT FORK	COIFFE CACHE-POUSSIÈRE FOURCHE	STAUBSCHUTZHAUBE, GABEL	CAPUCHON QUITAPOLVO HORQUILLA
SMS-TE	11	80A075097	4	VITE TCEI M6X1,00X25	SCREW TCEI M6X1.00X25	VIS TCEI M6X1,00X25	SCHRAUBE TCEI M6X1,00X25	TORNILLO TCEI M6X1,00X25
SMS-TE	12	800097727	1	STELO FORCELLA DESTRO	FORK INNER TUBE RH	TIGE FOURCHE DROITE	GABELSTANGE, RECHTS	MANGUITO HORQUILLA DERECHO
SMS-TE	13	800062796	8	VITE TEF M8X1,25X40 CH12	SCREW TEF M8X1.25X40 CH12	VIS TEF M8X1,25X40 CH12	SCHRAUBE TEF M8X1,25X40 CH12	TORNILLO TEF M8X1,25X40 CH12
SMS-TE	14	800079006	2	ANELLO PORTAMOLLA	RING	BAGUE	RING	ANILLO
SMS-TE	15	800079007	4	SEMIRONDELLA	HALF RING	DEMI BAGUE	HALBRING	SEMIANILLO
SMS-TE	16	8A0087717	1	GHIERA CANNOTTO STERZO	BOLT STEERING HEAD TOP	ECROU SUPERIEUR TETE DIRECTION	OBER-GEWINDE, STEUERKOPF	TUERCA SUPERIOR CABEZAL DIRECCION
SMS-TE	17	8000H5757	1	PIASTRA FORCELLA INFERIORE	STEM, STEERING	SOCLE DIRECTION	GABELBRUECKE, UNTEN	BASE DIRECCION
SMS-TE	18	8000H5758	1	PIASTRA FORCELLA SUPERIORE	HEAD, STEERING STEM	TETE DIRECTION	GABELKOPF	TIJA SUPERIOR
SMS-TE	19	800090093	4	VITE TCE M8X30 UNI5931	SCREW TCE M8X30 UNI5931	VIS TCE M8X30 UNI5931	SCHRAUBE TCE M8X30 UNI5931	TORNILLO TCE M8X30 UNI5931
SMS-TE	20	800097726	1	STELO FORCELLA SINISTRO	FORK INNER TUBE LH	TIGE FOURCHE GAUCHE	GABELSTANGE, LINKS	MANGUITO HORQUILLA IZQUERDO
SMS-TE	21	8000H5948	2	CAVALLOTTO MANUBRIO SUPERIORE	HANDLEBAR BRACKET, UPPER	BRIDE GUIDON, SUPERIEURE	LENKER BUEGELBOLZEN, OBERE	PUENTE MANILLAR, SUPERIOR
SMS-TE	22	8000H5760	1	GAMBA FORCELLA SINISTRA	FRONT CUSHION ASSY LEFT	JAMBE FOURCHE GAUCHE	GABELBEIN, LINKS	PIERNA HORQUILLA IZQUERDA
SMS-TE	23	8A0069315	1	DADO CANNOTTO M26X1 CH30	NUT, STEERING STEM M26X1 CH30	ECROU FOURCHE M26X1 CH30	GABELMUTTER M26X1 CH30	TUERCA HORQUILLA M26X1 CH30
SMS-TE	24	800079008	1	GRUPPO REVISIONE FORCELLA	FRONT FORK OVERHAUL SET	GROUPE REVISION FOURCHE AVANT	VORDESGABEL EBERHOLUNGSGRUPPE	GRUPO REVISION HORQUILLA DELANTERA
SMS-TE	25	80C069337	1	PROTEZIONE STELO FORCELLA SINISTRO	GUARD FORK TUBE, LH	PROTECTION TIGE FOURCHE GAUCHE	GABELSTANGENSCHUTZ LINKS	PROTECCION VARILLA IZQUERDA
SMS-TE	26	80C069338	1	PROTEZIONE STELO FORCELLA DESTRO	GUARD FORK TUBE, RH	PROTECTION TIGE FOURCHE DROITE	GABELSTANGENSCHUTZ RECHTS	PROTECCION VARILLA DERECHA
SMS-TE	27	8000A8423	6	VITE FLANGIATA M6X8	BOLT, FLANGE M6X8	VIS A EMBASE M6X8	GEFLANSCHSCHRAUBE M6X8	TORNILLO CON VALONA M6X8
SMS-TE	28	80A0A0633	1	FERMACAVO	CLAMP, WIRE	COLLIER, CORDON	KABELKLEMME	GRAMPA CORDON
SMS		ZKHA500ABBV000354		Dalla matricola	From serial number	Du matricule	Vom Matrikell	Desde la matrícula
TE		ZKHA500AABV000173		Dalla matricola	From serial number	Du matricule	Vom Matrikel	Desde la matrícula

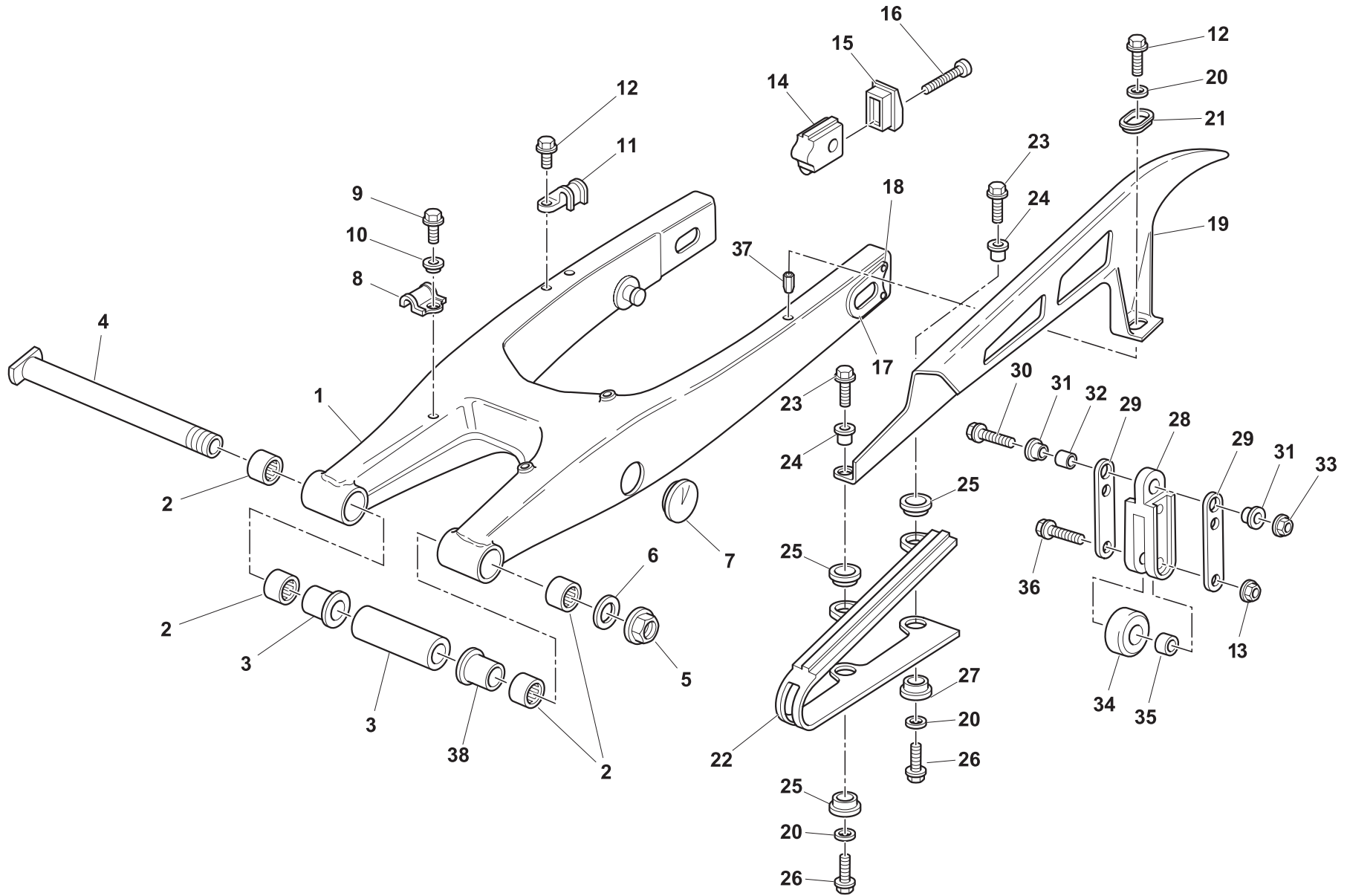

## FORCELLONE POSTERIORE- REAR SWING ARM- FOURCHE ARRIERE - HINTERGABEL HORQUILLA TRASERA

Note Notes Marke Notas	Pos. No. Index Pos.	N. Cod. Code No. Nr. Code Code Nr N. Cod.	Q.tà Q.ty Q.te M.ge C.ad	DENOMINAZIONE	NAME	DESIGNATION	BESHREIBUNG	DENOMINACION
	1	8A0074794	1	FORCELLONE	REAR SWING ARM	BRAS OSCILLANT	HINTERE SCHWINGARM	BASCULANTE
	2	800076283	4	GABBIA A RULLI 22X28X11	BEARING, NEEDLE 22X28X11	ROULEMENT A AIGUILLES 22X28X11	NADELLAGER 22X28X11	COJINETE DE AGUJAS 22X28X11
	3	800071621	2	BOCCOLA FORCELLONE 49,5 MM	COLLAR, SWINGARM 49.5 MM	DOUILLE, BRAS OSCILLANT 49,5 MM	BUCHSE, SCHWINGARM 49,5 MM	BUJE BASCULANTE 49,5 MM
	4	800071620	1	PERNO FORCELLONE	AXLE REAR SWING ARM	AXE BRAS OSCILLANT	SCHWINGENACHSE	PERNO BASCULANTE
	5	Z00071623	1	DADO FLANGIATO M16X1,5	NUT FLANGE M16X1.5	ECROU BRIDE M16X1,5	GEFLANSCHTE MUTTER M16X1,5	TUERCA CON REBORDE M16X1,5
	6	800032388	1	RONDELLA 26X17,2X1,5	WASHER 26X17.2X1.5	RONDELLE 26X17,2X1,5	SCHEIBE 26X17,2X1,5	ARANDELA 26X17,2X1,5
	7	80A074388	2	TAPPO	PLUG	BOUCHON	VERSCHLUSS	TAPON
	8	80A073456	1	GUIDA TUBO FRENO POSTERIORE	GUIDE, REAR BRAKE HOSE	GUIDE TUYAU FREIN ARRIERE	BREMSSCHLAUCH HINTENFUEHRUNG	GUIA MANGUERA FRENO TRASERO
	9	Z00067997	1	VITE TEF M5X0,8X12 CH8	SCREW TEF M5X0.8X12 CH8	VIS TEF M5X0,8X12 CH8	SCHRAUBE TEF M5X0,8X12 CH8	TORNILLO TEF M5X0,8X12 CH8
	10	800069282	1	BOCCOLA 14X7X5,25 MM	BUSH 14X7X5.25 MM	DOUILLE 14X7X5,25 MM	BUCHSE 14X7X5,25 MM	CASQUILLO 14X7X5,25 MM
	11	80A059299	1	GUIDA TUBO FRENO POSTERIORE	GUIDE, REAR BRAKE HOSE	GUIDE TUYAU FREIN ARRIERE	BREMSSCHLAUCH HINTENFUEHRUNG	GUIA MANGUERA FRENO TRASERO
	12	Z00020536	3	VITE AUTOFILETTANTE 4,8X13	SCREW SELF-TAPPING 4.8X13	VIS TARAUD 4,8X13	GEWINDESCHRAUBE 4,8X13	TORNILLO AUTOROSCANTE 4,8X13
	13	Z00061313	2	DADO M6X1 H6 CH10	NUT M6X1 H6 CH10	ECROU M6X1 H6 CH10	MUTTER M6X1 H6 CH10	TUERCA M6X1 H6 CH10
	14	800074815	2	TENDICATENA	PULLER, CHAIN	TENDEUR CHAINE	KETTENSANNER	TENSIONADOR CADENA
	15	80C074816	2	COPERCHIO TENDICATENA	COVER TENSIONER HOLE	COUVERCLE	DECKEL	CUBIERTA
	16	Z00062400	2	VITE TCEI M8X1,25X50	SCREW	VIS	SCHRAUBE	TORNILLO
	17	8A0062802	2	PIASTRINA REGOLAZIONE CATENA	CHAIN ADJUSTING PLATE	PLAQUETTE REGLAGE CHAINE	PLAETTCHEN, KETTENSANNER	PLACA REGULACION CADENA
	18	800033372	4	RIVETTO A STRAPPO 3,8X8	RIVET, BLIND 3.8X8	RIVET 3,8X8	NIETE 3,8X8	REMACHE CIEGO 3,8X8
	19	8AB076028	1	CARTER CATENA	GUARD, CHAIN	CARTER CHAINE	KETTENGEHAUSE	CARTER CADENA
	20	800036137	3	RONDELLA 11X5,5X1,5	WASHER 11X5.5X1.5	RONDELLE 11X5,5X1,5	SCHEIBE 11X5,5X1,5	ARANDELA 11X5,5X1,5
	21	8000H3033	1	SCODELLINO	CUP	COUPELLE	EINSTELLE	COPELA
	22	800072884	1	PATTINO SCORRICATENA FORCELLONE	BUFFER, CHAIN TOUCH DEFENSE	PATIN PROTECTEUR BRAS OSCILLANT	KETTENLEITFUEHRUNG	PATIN DESLIZAMIENTO CADENA
	23	ZC0067997	2	VITE TEF M5X0,8X20 CH8	SCREW TEF M5X0.8X20 CH8	VIS TEF M5X0,8X20 CH8	SCHRAUBE TEF M5X0,8X20 CH8	TORNILLO TEF M5X0,8X20 CH8
	24	8A0069282	2	DISTANZIALE 14X7X5,25 MM	SPACER 14X7X5.25 MM	ENTRETOISE 14X7X5,25 MM	ABSTANDHALTER 14X7X5,25 MM	DISTANCIADOR 14X7X5,25 MM
	25	8000H3034	3	SCODELLINO	CUP	COUPELLE	EINSTELLE	COPELA
	26	ZA0067997	2	VITE TEF M5X0,8X16 CH8	SCREW TEF M5X0.8X16 CH8	VIS TEF M5X0,8X16 CH8	SCHRAUBE TEF M5X0,8X16 CH8	TORNILLO TEF M5X0,8X16 CH8
	27	8000H3033	1	SCODELLINO	CUP	COUPELLE	EINSTELLE	COPELA
	28	800072874	1	CRUNA CATENA	GUIDE, CHAIN	GUIDE CHAINE	KETTENFUEHRUNG	GUIA CADENA
	29	800076002	2	PIASTRA	PLATE	PLAQUE	PLATTE	PLACA
	30	Z00062795	1	VITE TEF M8X1,25X50 CH12	SCREW TEF M8X1.25X50 CH12	VIS TEF M8X1,25X50 CH12	SCHRAUBE TEF M8X1,25X50 CH12	TORNILLO TEF M8X1,25X50 CH12
	31	8000H3019	2	DISTANZIALE 20X12X8,5	SPACER 20X12X8.5	ENTRETOISE 20X12X8,5	ABSTANDHALTER 20X12X8,5	DISTANCIADOR 20X12X8,5
	32	8A0036984	1	DISTANZIALE 18X8,5	SPACER 18X8.5	ENTRETOISE 18X8,5	ABSTANDHALTER 18X8,5	DISTANCIADOR 18X8,5
	33	Z0B043928	1	DADO AUTOBLOCCANTE M8X1,25	NUT M8X1.25 H8 CH12	ECROU M8X1,25 H8 CH12	MUTTER M8X1,25 H8 CH12	TUERCA M8X1,25 H8 CH12

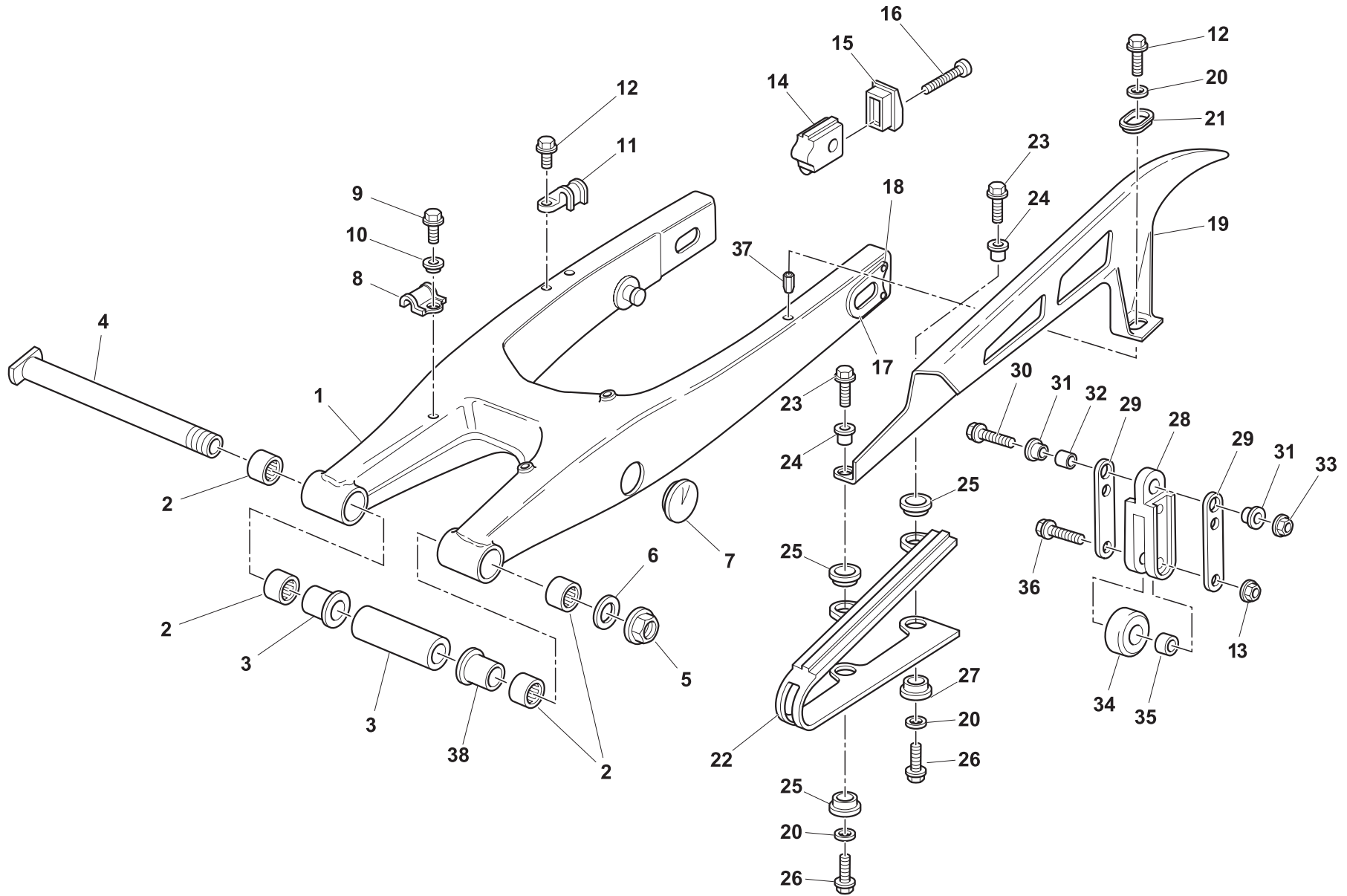



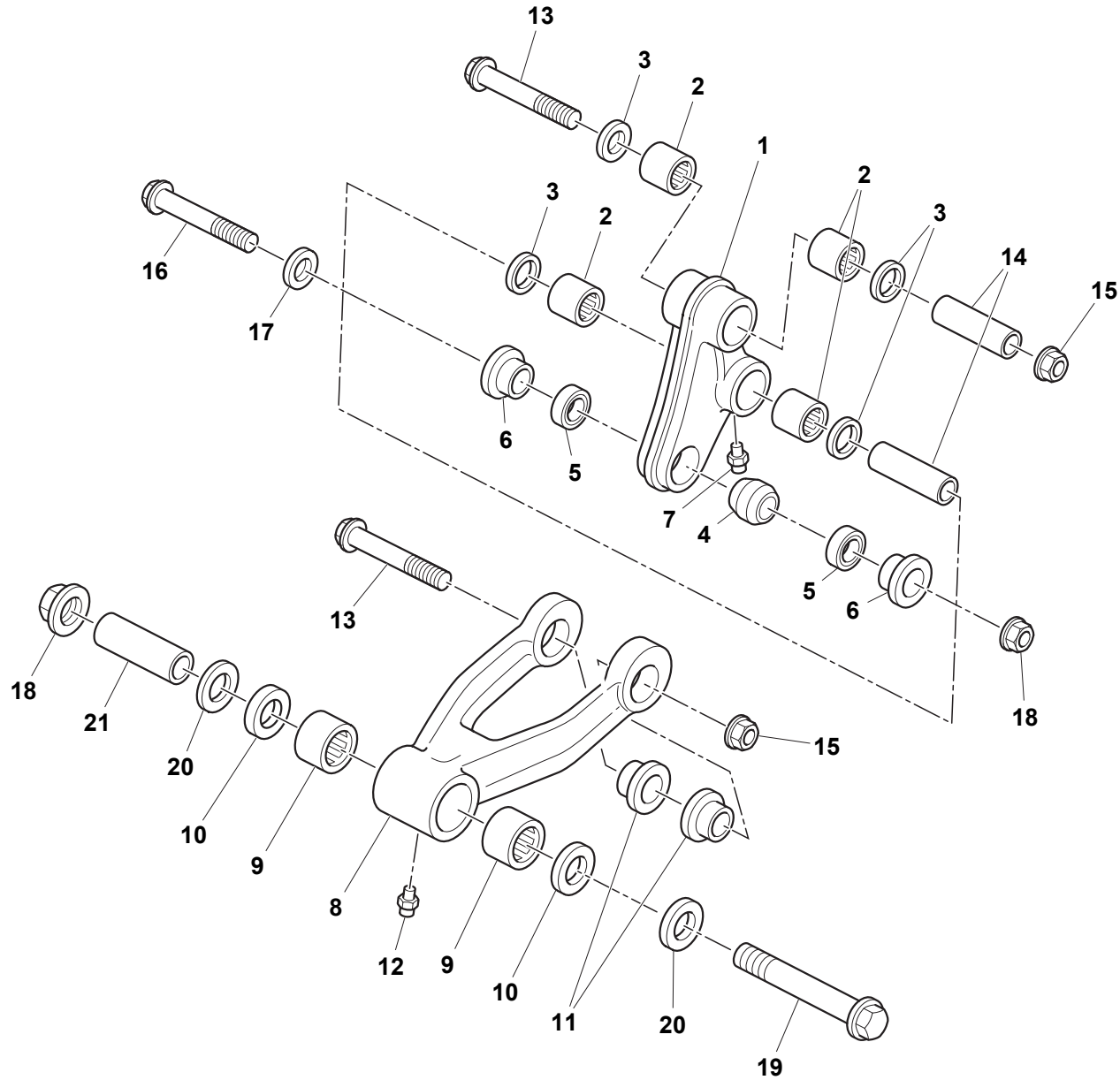



## LEVERAGGI SOSPENSIONE POSTERIORE - REAR SUSPENSION LINKAGE LEVIER SUSPENSION ARRIERE - HEBELWERK HINTERHAUFHANGUNG PALANCA SUSPENSION TRASERA

Note Notes Marke Notas	Pos. No. N. Index Pos.	N. Cod. Code No. Nr. Code Code Nr. N. Cod.	Q.tà Q.ty Q.te M.ge C.ad	DENOMINAZIONE	NAME	DESIGNATION	BESHREIBUNG	DENOMINACION
	1	800073348	1	BILANCIERE SOSPENSIONE POSTERIORE	SWINGARM, CUSHION RELAY	CULBUTEUR SUSPENSION ARRIERE	KIPPSCHWINGE, HINTEN FEDERUNG	BRAZO SUSPENSION TRASERO
	2	800042781	4	ASTUCCIO A RULLI HK2020	BEARING, NEEDLE HK2620	ROULEMENT A AIGUILLES HK2620	NADELLAGER HK2620	COJINETE DE AGUJAS HK2620
	3	800032065	4	PARAOLIO 26X20X4	SEAL, OIL 26X20X4	BAGUE D'ETANCHEITE 26X20X4	WELLENDICHRING 26X20X4	RETEN ACEITE 26X20X4
	4	800072168	1	SNODO SFERICO 12X26X16	BALL JOINT 12X26X16	JOINT A ROTULE 12X26X16	KUGELGELENK 12X26X16	ROTULA ESFERICA 12X26X16
	5	800038767	2	PARAOLIO 26X15X4	OIL SEAL 26X15X4	BAGUE D'ETANCHEITE 26X15X4	WELLENDICHRING 26X15X4	RETEN DE ACEITE 26X15X4
	6	151133302	2	BOCCOLA	BUSH	DOUILLE	BUCHSE	BUJE
	7	800001412	1	INGRASSATORE M6X1	NIPPLE, GREASE M6X1	GRAISSEUR M6X1	SCHMIERNIPPEL M6X1	NIPLE GRASERA M6X1
	8	8D0068157	1	BIELLA SOSPENSIONE POSTERIORE	ARM RELAY, REAR CUSHION LEVER	BIELLE SUSPENSION ARRIERE	PLEUELSTANGE HINTEN FEDERUNG	BIELA SUSPENSION TRASERA
	9	800038956	2	ASTUCCIO A RULLI HK1816	BEARING, NEEDLE HK1816	ROULEMENT A AIGUILLESHK1816	NADELLAGER HK1816	COJINETE DE AGUJAS HK1816
	10	800038957	2	PARAOLIO 24X18X4	OIL SEAL 24X18X4	BAGUE D'ETANCHEITE 24X18X4	WELLENDICHRING 24X18X4	RETEN DE ACEITE 24X18X4
	11	8B0042029	2	BOCCOLA 28X15X13	BUSH 28X15X13	DOUILLE 58X15X13	BUCHSE 58X15X13	BUJE 58X15X13
	12	800001412	1	INGRASSATORE M6X1	NIPPLE, GREASE M6X1	GRAISSEUR M6X1	SCHMIERNIPPEL M6X1	NIPLE GRASERA M6X1
	13	Y00074372	2	VITE TEF M12X1,25 CH15	SCREW TEF M12X1.25 CH15	VIS TEF M12X1,25 CH15	SCHRAUBE TEF M12X1,25 CH15	TORNILLO TEF M12X1,25 CH15
	14	8A0075153	2	SPINOTTO	PIN	GOUJON	BOLZEN	EJE
	15	Z00042023	2	DADO M12X1,25	NUT M12X1.25	ECROU M12X1,25	MUTTER M12X1,25	TUERCA M12X1,25
	16	ZA0062797	1	VITE TE M10X1,25X50 CH14	SCREW TE M10X1.25X50 CH14	VIS TE M10X1,25X50 CH14	SCHRAUBE TE M10X1,25X50 CH14	TORNILLO TE M10X1,25X50 CH14
	17	8AA036237	1	RONDELLA 20X10,3	WASHER 20X10,3	RONDELLE 20X10,3	SCHEIBE 20X10,3	ARANDELA 20X10,3
	18	Z00042022	2	DADO M10X1,25 H10 CH14	NUT M10X1.25 H10 CH14	ECROU M10X1,25 H10 CH14	MUTTER M10X1,25 H10 CH14	TUERCA M10X1,25 H10 CH14
	19	ZA0069138	1	VITE TETS M10X1,25 CH13	SCREW TETS M10X1.25 CH13	VIS TETS M10X1,25 CH13	SCHRAUBE TETS M10X1,25 CH13	TORNILLO TETS M10X1,25 CH13
	20	800073394	2	ANELLO IN FELTRO	SEAL FELT 30X18X2	BAGUE EN FELTRE 30X18X2	FILZRING 30X18X2	ANILLO DE FIELTRO 30X18X2
	21	800059839	1	SPINOTTO	PIN	GOUJON	BOLZEN	EJE

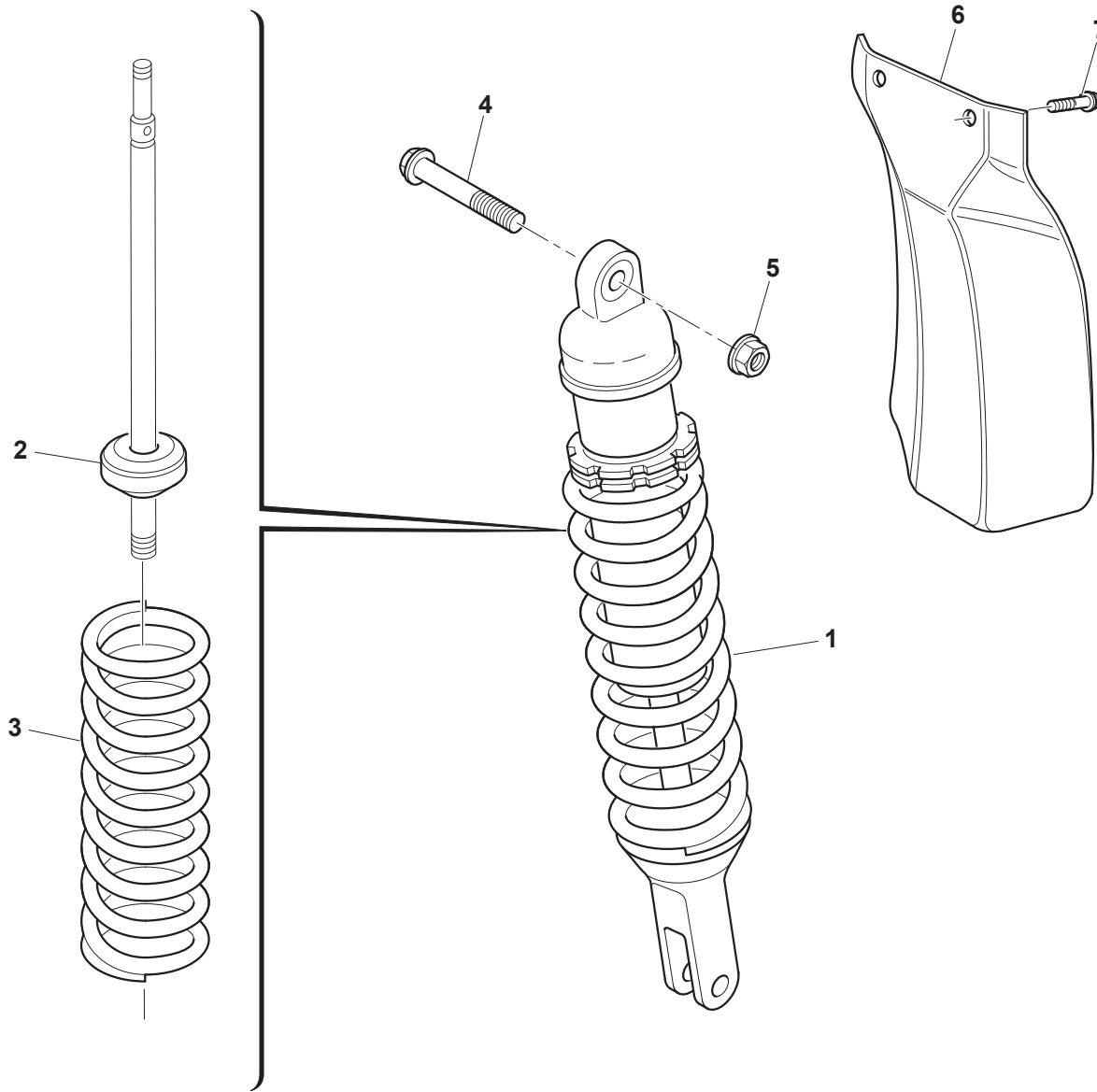



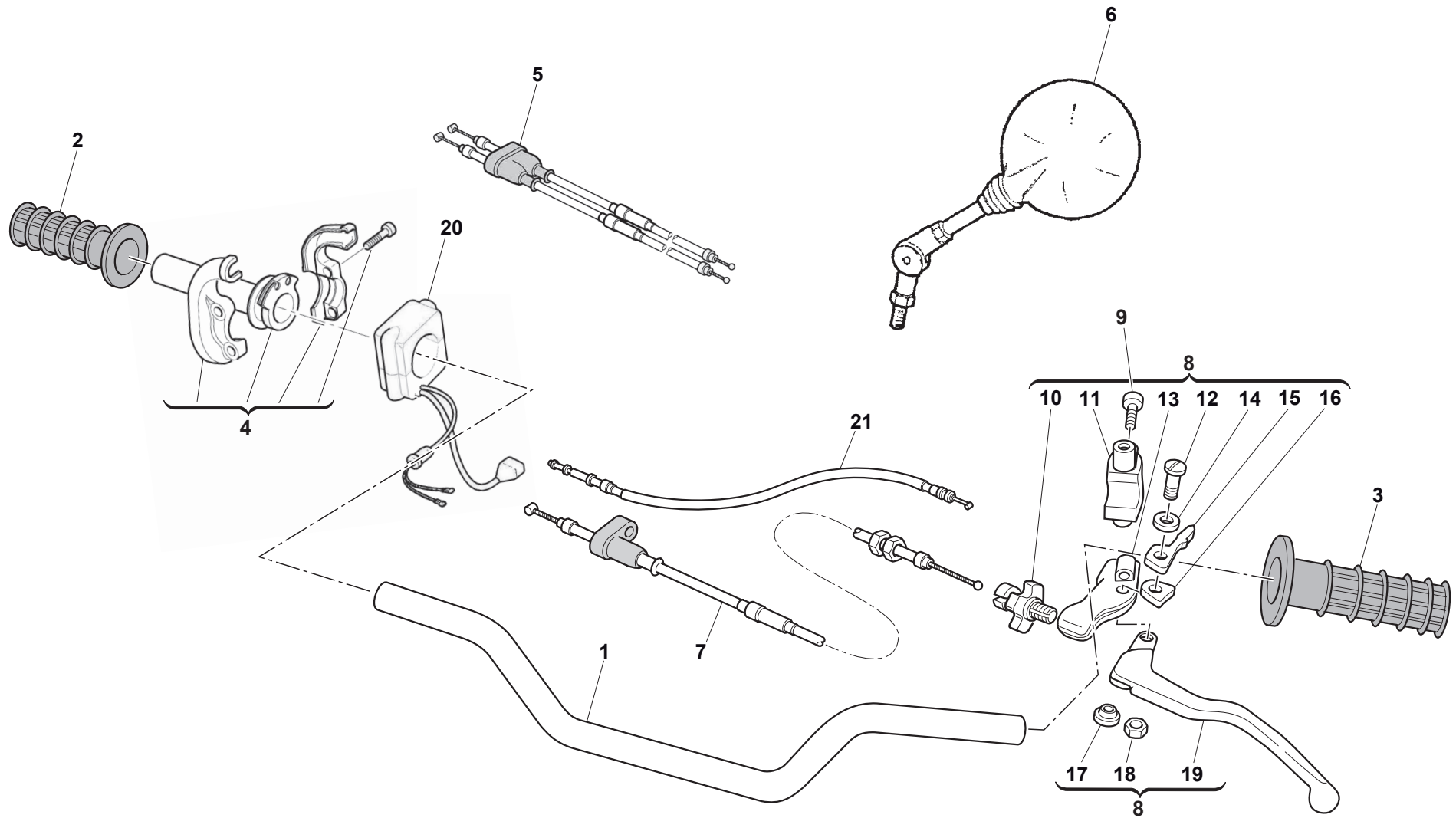

## MANUBRIO E COMANDI - HANDLEBAR AND CONTROLS GUIDON ET COMMANDES - LENKER UND STEUERORGANE MANILLAR Y MANDOS

Note Notes Marke Notas	Pos. No. N. Index Pos.	N. Cod. Code No. Nr. Code Code Nr. N. Cod.	Q.tà Q.ty Q.te M.ge C.ad	DENOMINAZIONE	NAME	DESIGNATION	BESHREIBUNG	DENOMINACION
	1	8000H0044	1	MANUBRIO	HANBLEBAR	GUIDON	LENKER	MANILLAR
	2	800076688	1	MANOPOLA DESTRA	HAND GRIP RH	POIGNEE DROIT	HANDGRIFF RECHTS	PUNO DERECHO
	3	800076687	1	MANOPOLA SINISTRA	HAND GRIP LH	POIGNEE GAUCHE	HANDGRIFF LINKS	PUNO IZQUERDO
	4	800098209	1	COMANDO GAS	GRIP, THROTTLE	COMMANDE GAZ	GASSCHALTUNG	MANDO ACELERADOR
	5	8000H3107	1	CAVO GAS	CABLE, THROTTLE	CABLE GAZ	GASSEIL	CABLE ACELERADOR
	6	8000H3500	2	SPECCHIO	MIRROR	MIROIR	SPIEGEL	ESPEJO
	7	8000H7481	1	CAVO FRIZIONE	CABLE, CLUTCH	CABLE EMBRAYAGE	KUPPLUNGSKABEL	CABLE EMBRAGUE
	8	8A0087054	1	COMANDO FRIZIONE	CLUTCH CONTROL	COMMANDE EMBRAYAGE	KUPPLUNGHEBELSCHALTUNG	MANDO EMBRAGUE
	9	Z00062729	2	VITE TEF M6X1X25 CH8	SCREW TEF M6X1X25 CH8	VIS TEF M6X1X25 CH8	SCHRAUBE TEF M6X1X25 CH8	TORNILLO TEF M6X1X25 CH8
	10	800067355	1	VITE REGISTRO CAVO	SCREW CABLE ADJUSTING	VIS REGLAGE	EINSTELLSCHRAUBE	TORNILLO REGULADOR CABLE
	11	800078915	1	CAVALLOTTO COMANDO FRIZIONE	BRACKET, CLUTCH CONTROL	BRIDE COMMANDE EMBRAYAGE	BUEGELBOLZEN KUPPLUNGSHEBEL	PUENTE MANDO EMBRAGUE
	12	800089815	1	VITE LEVA TE M6X1X34	BOLT, LEVER TE M6X1X34	VIS LEVIER TE M6X1X34	SCHRAUBE, HEBEL TE M6X1X34	TORNILLO PALANCA TE M6X1X34
	13	8A0088746	1	SUPPORTO LEVA FRIZIONE	BRACKET, CLUTCH LEVER	SUPPORT LEVIER EMBRAYAGE	HALTER, KUPPLUGSHEBEL	SOPORTE PALANCA EMBRAGUE
	14	800047826	1	RONDELLA LEVA STARTER	WASHER, STARTER LEVER	RONDELLE	SCHEIBE	ARANDELA
	15	800047822	1	LEVA STARTER	STARTER LEVER SET	LEVIER, STARTER	HEBEL, STARTER	PALANCA STARTER
	16	800087276	1	PIASTRINA FERMO LEVA STARTER	PLATE	PLAQUETTE	PLAETTCHEN	PLACA
	17	800089814	1	DISTANZIALE	SPACER	ENTRETOISE	ABSTANDHALTER	DISTANCIADOR
	18	800061313	1	DADO M6X1 H6 CH10	NUT M6X1 H6 CH10	ECROU M6X1 H6 CH10	MUTTER M6X1 H6 CH10	TUERCA M6X1 H6 CH10
	19	800089813	1	LEVA FRIZIONE	LEVER, CLUTCH	LEVIER EMBRAYAGE	KUPPLUNGSHEBEL	PALANCA EMBRAGUE
	20	8000H1174	1	COMMUTATORE LUCI DESTRO	HANDLE SWITCH, RH	COMMUTATEUR FEUX DROITE	RECHTER LICHTSCHALTER	CONMUTADOR LUCES DERECHO
	21	8000H3108	1	CAVO STARTER	CABLE, STARTER	CABLE COMMANDE STARTER	STARTERKABEL	CABLE STARTER



TAVOLA 29  
DRAWING 29  
TABLE 29  
BILD 29  
TABLA 29

**PANNELLI, PARAFANGHI, SELLA - PANEL, FENDERS, SEAT**  
**PANNEAU, GARDE-BOUES, SIEGE - STREIFEN, KOTFLUGEL, SATTEL**  
**PANELO, GUARDABARROS, SILLIN**

Note Notes Marke Notas	Pos. No. Index Pos.	N. Cod. Code No. Nr. Code Code Nr N. Cod.	Q.tà Q.ty Q.te M.ge C.ad	DENOMINAZIONE	NAME	DESIGNATION	BESHREIBUNG	DENOMINACION
	1	80C0H0198	1	CUPOLINO	COWLING	CAPOT	KOPFVERKLEIDUNG	CUPULA
	2	8000A0864	1	GUIDA TUBO FRENO ANTERIORE	GUIDE, FRONT BRAKE HOSE	GUIDE TUYAU FREIN AVANT	BREMSSCHLAUCH VORNEFUEHRUNG	GUIA MANGUERA FRENO DELANTERO
	3	ZA0037283	2	VITE AUTOFILETTANTE AB 3,5X13	SCREW SELF-TAPPING AB 3.5X13	VIS TARAUD AB 3,5X13	GEWINDESCHRAUBE AB 3,5X13	TORNILLO AUTOROSCANTE AB 3,5X13
	4	U00055134	1	DADO ELASTICO M5X0,8	NUT M5X0,8	ECROU M5X0,8	MUTTER M5X0,8	TUERCA M5X0,8
	5	8B00A8421	2	VITE FLANGIATA M5X16	SCREW M5X14	VIS M5X16	SCHRAUBE M5X16	TORNILLO M5X16
	6	ZC0069429	4	BOCCOLA 9X7X9,5 MM	BUSH 9X7X4,8 MM	DOUILLE 9X7X4,8 MM	BUCHSE 9X7X4,8 MM	BUJE 9X7X4,8 MM
	7	8000H3006	1	SUPPORTO CUPOLINO	BRACKET, COWLING	SUPPORT CAPOT	KONSOLE, KOPFVERKLEIDUNG	SOPORTE CUPULA
TE125/11	8	80A0A4198	1	SUPPORTO PARAFANGO ANTERIORE	FRONT FENDER BRACKET	EQUERRE GARDE-BOUE AVANT	KONSOLE VORNE KOTFLUEGEL	SOPORTE GUARDABARROS DELANTERO
TE125/11	9	Z00065535	2	VITE TCEI M5X0,8X14	SCREW	VIS	SCHRAUBE	TORNILLO
TE125/11	10	Z00061535	2	DADO	NUT	ECROU	MUTTER	TUERCA
TE125/11	11	62ND15548	2	RONDELLA 15X5,3X1	WASHER 15X5,3X1	RONDELLE 15X5,3X1	SCHEIBE 15X5,3X1	ARANDELA 15X5,3X1
SMS125/11	12	8AC0H0525	1	PARAFANGO ANTERIORE	FENDER, FRONT	GARDE BOUE AVANT	KOTFLUEGEL VORNE	GUARDABARROS DELANTERO
TE125/11	12	8AC0H0878	1	PARAFANGO ANTERIORE	FENDER, FRONT	GARDE BOUE AVANT	KOTFLUEGEL VORNE	GUARDABARROS DELANTERO
	13	Z00062729	4	VITE TEF M6X1X25 CH8	SCREW TEF M6X1X25 CH8	VIS TEF M6X1X25 CH8	SCHRAUBE TEF M6X1X25 CH8	TORNILLO TEF M6X1X25 CH8
	14	Z00048814	4	RONDELLA 18X6,4X2 MM	WASHER 18X6,4X2 MM	RONDELLE 18X6,4X2 MM	SCHEIBE 18X6,4X2 MM	ARANDELA 18X6,4X2 MM
SMS125/11	15	8000H2338	1	FIANCHETTO DESTRO	COVER FRAME RIGHT	COUVERCLE CADRE DROIT	SEITENDECKEL, RECHTS	CUBIERTA BASTIDOR DERECHA
TE125/11	15	8000H2062	1	FIANCHETTO DESTRO	COVER, FRAME RH	COUVERCLE CADRE DROIT	SEITENDECKEL, RECHTS	CUBIERTA BASTIDOR DERECHA
	16	8B00A8421	6	VITE FLANGIATA M5X16	SCREW M5X14	VIS M5X16	SCHRAUBE M5X16	TORNILLO M5X16
	17	8000A8792	1	SELLA	SEAT	SELLE	SITZBANK	ASIENTO
	18	86610191A	1	TAMPONE IN GOMMA	CUSHION RUBBER	TAMPON EN CAOUTCHOUC	GUMMISTOPFEN	TAMPON GOMA
	19	800069148	1	PERNO ATTACCO SELLA	PIN, SADDLE	AXE SELLE	SITZACHSE	PERNO ASIENTO
	20	800069149	1	RONDELLA 17X9X1	WASHER 17X9X1	RONDELLE 17X9X1	SCHEIBE 17X9X1	ARANDELA 17X9X1
SMS125/11	21	8000H2337	1	FIANCHETTO SINISTRO	COVER FRAME LEFT	COUVERCLE CADRE GAUCHE	SEITENDECKEL, LINKS	CUBIERTA BASTIDOR IZQUERDA
TE125/11	21	8000H2064	1	FIANCHETTO SINISTRO	COVER, FRAME LH	COUVERCLE CADRE GAUCHE	SEITENDECKEL, LINKS	CUBIERTA BASTIDOR IZQUERDA
	22	8H0067997	1	VITE TEF M5X0,8X22 CH8	SCREW TEF M5X0,8X22 CH8	VIS TEF M5X0,8X22 CH8	SCHRAUBE TEF M5X0,8X22 CH8	TORNILLO TEF M5X0,8X22 CH8
	23	80C0H0803	1	PARAFANGO POSTERIORE	FENDER, REAR	GARDE-BOUE ARRIERE	KOTFLUEGEL HINTEN	GUARDABARROS TRASERO
	24	800072494	1	MOLLETTA FERMACAVO	CLAMP, WIRE	COLLIER, CORDON	KABELBINDER	GRAMPA CORDON
	25	8A00A5377	1	SUPPORTO PORTATARGA	BRACKET, NUMBER-PLATE	PORTE-PLAQUE IMMATRICULATION	KONSOLE KENNZEICHEN	PORTAMATRICULA
	26	8000H3188	4	ANTIVIBRANTE ADESIVO	VIBRATION DAMPER	ANTIVIBRATION	SCHWINGUNGSDAEMPFER	ANTI-VIBRACION
	27	Z00062729	2	VITE TEF M6X1X25 CH8	SCREW TEF M6X1X25 CH8	VIS TEF M6X1X25 CH8	SCHRAUBE TEF M6X1X25 CH8	TORNILLO TEF M6X1X25 CH8
	28	ZC0069429	2	BOCCOLA 9X7X9,5 MM	BUSH 9X7X4,8 MM	DOUILLE 9X7X4,8 MM	BUCHSE 9X7X4,8 MM	BUJE 9X7X4,8 MM
	29	Z00061313	2	DADO M6X1 H6 CH10	NUT M6X1 H6 CH10	ECROU M6X1 H6 CH10	MUTTER M6X1 H6 CH10	TUERCA M6X1 H6 CH10
	30	8000A7860	1	PARAFANGO POSTERIORE PORTATARGA	FENDER, REAR NUMBER PLATE HOLDER	GARDE-BOUE ARRIERE PORTE-PLAQUE	KOTFLUEGEL HINTEN KENNZEICHEN	GUARDABARROS TRASERO PORTA-MATRICULA

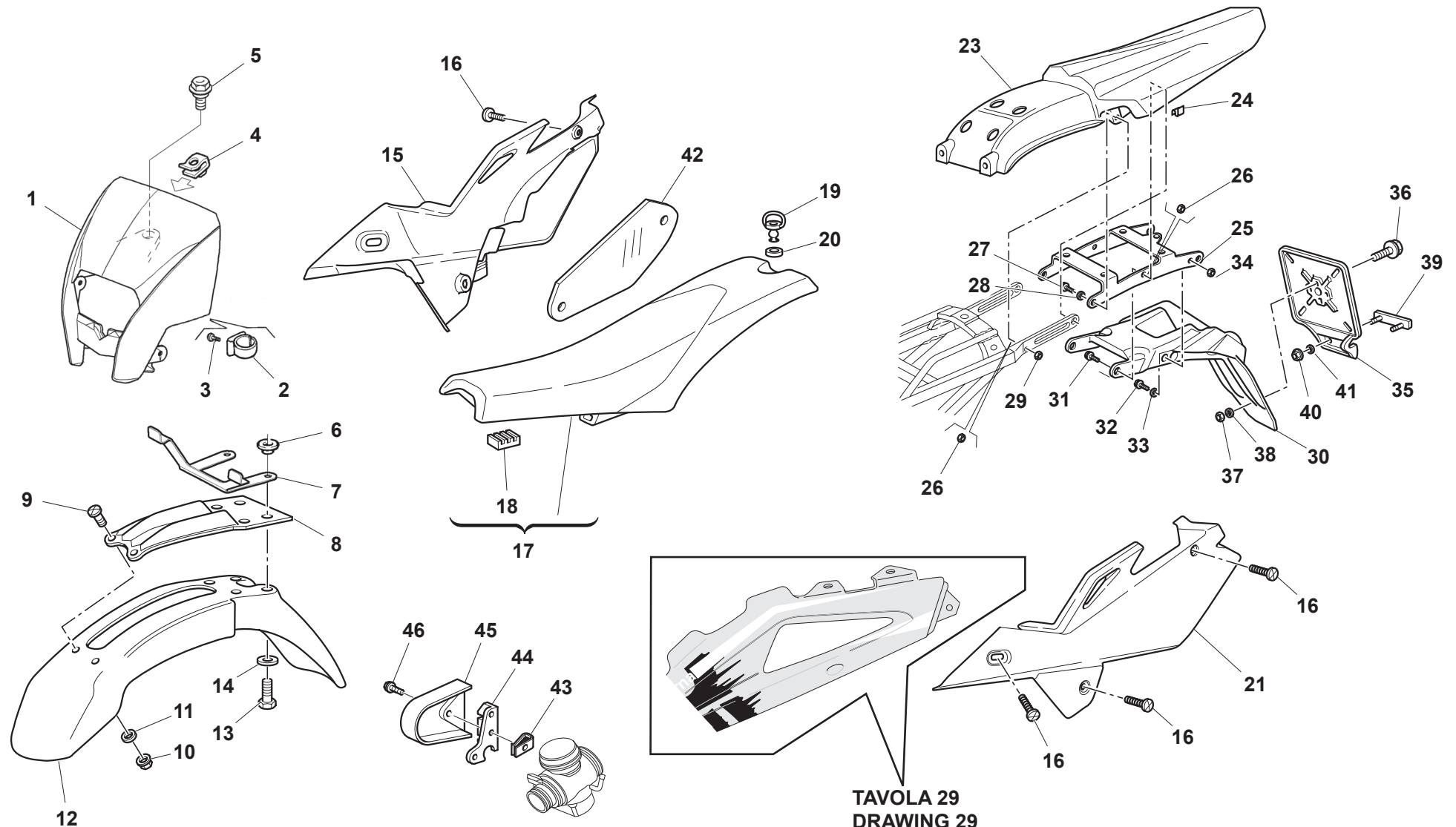

TAVOLA 29  
DRAWING 29  
TABLE 29  
BILD 29  
TABLA 29





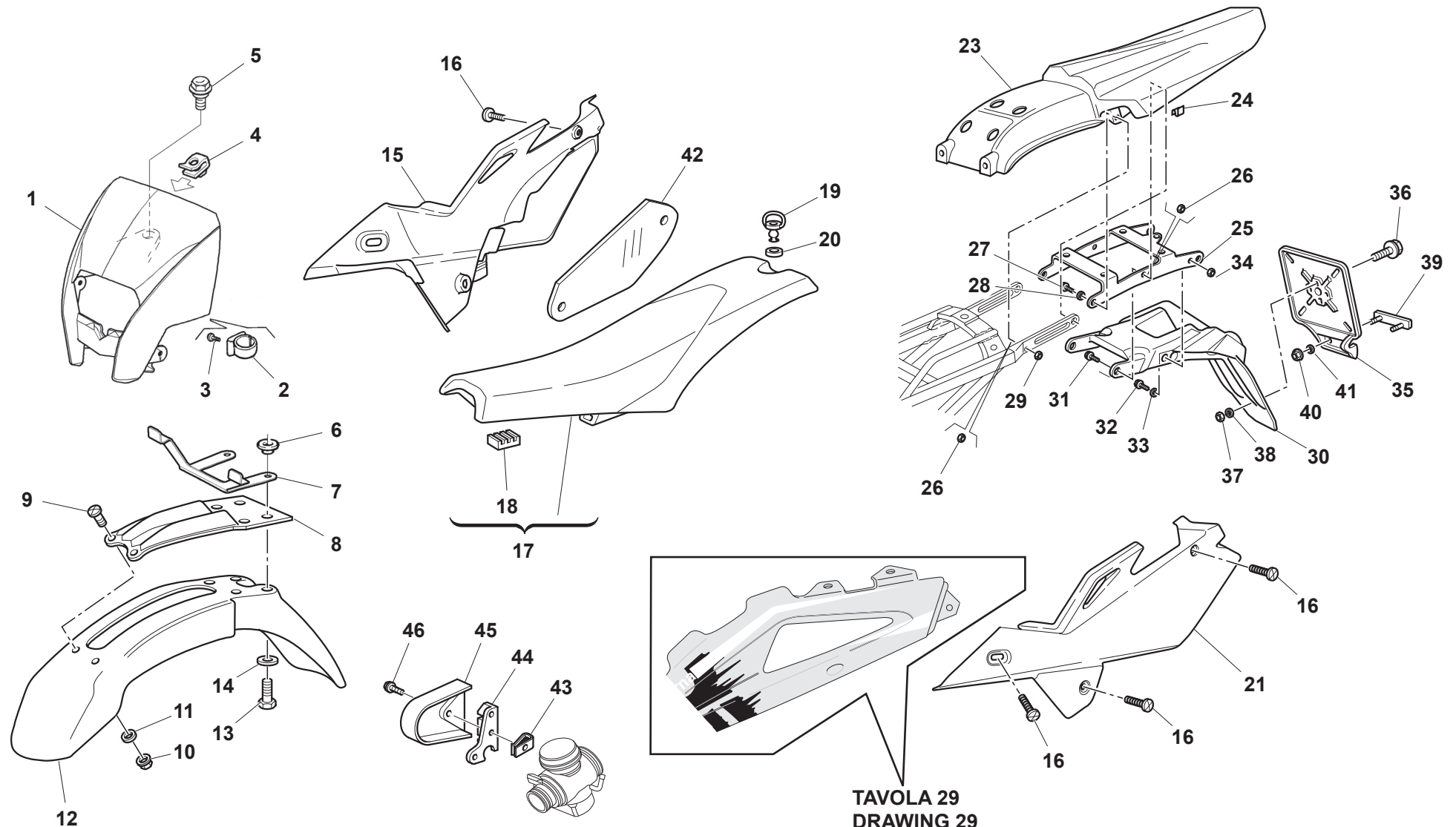
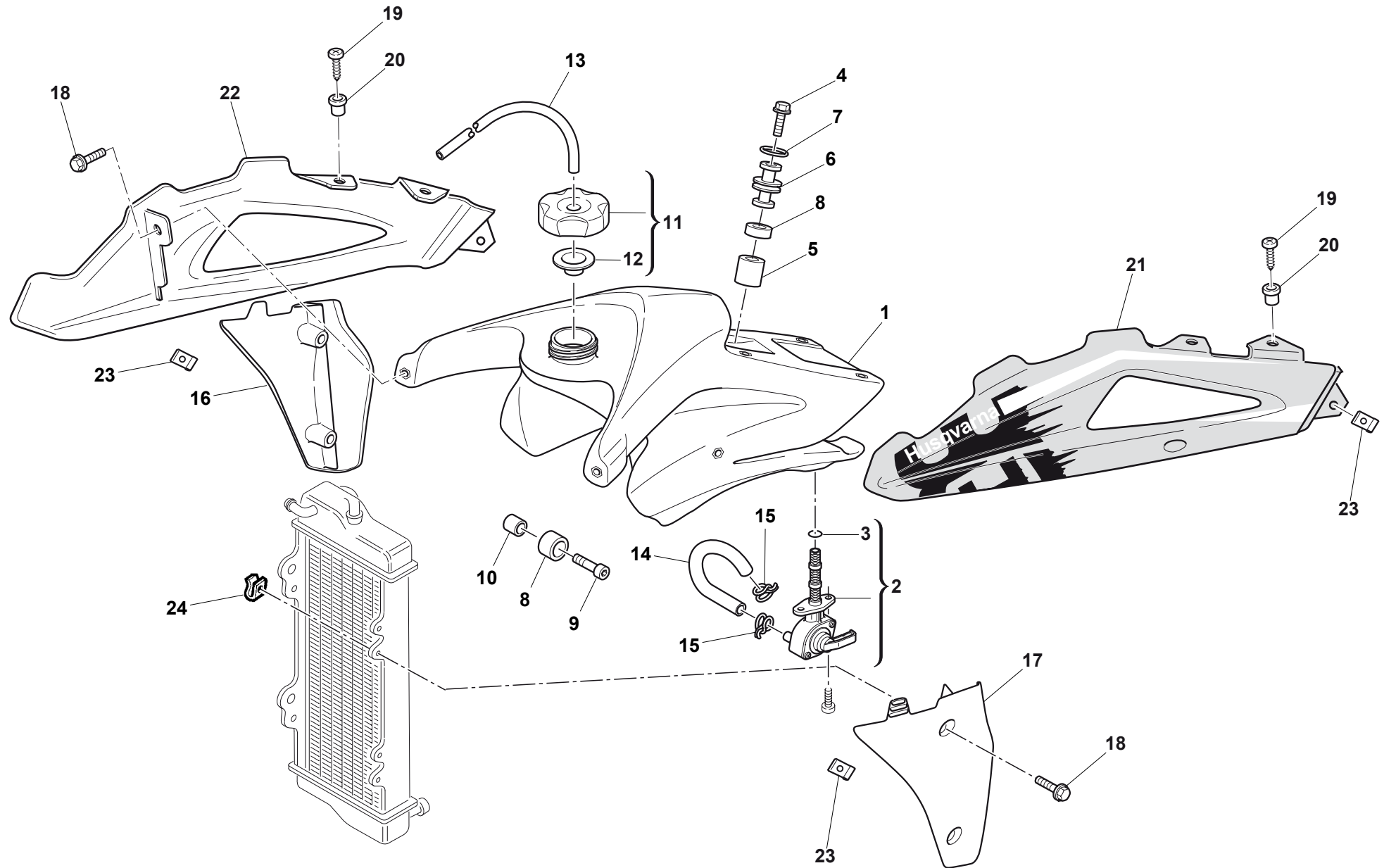

## SERBATOIO CARBURANTE, CONVOGLIATORI - GAS TANK, PANEL - RESERVOIR CARBURANT, FLANC - KRAFTSTOFFBEHALTER, FLANKE - DEPOSITO GASOLINA, LATERAL

Note Notes Marke Notas	Pos. No. N. Index Pos.	N. Cod. Code No. Nr. Code Code Nr N. Cod.	Q.tà Q.ty Q.te M.ge C.ad	DENOMINAZIONE	NAME	DESIGNATION	BESHREIBUNG	DENOMINACION
	1	80A0A5507	1	SERBATOIO CARBURANTE	FUEL TANK	RESERVOIR CARBURANT	KRAFTSTOFFTANK	DEPOSITO CARBURANTE
	2	8000H4503	1	RUBINETTO CARBURANTE	FUEL COCK	ROBINET ESSENCE	KRAFTSTOFFHAHN	GRIFO GASOLINA
	3	8000H4520	1	ANELLO O-RING 10,78X 2,62 VITON 70	O-RING 2,62X10,78 VITON 70	JOINT TORIQUE 2,62X10,78 VITON 70	O-RING 2,62X10,78 VITON 70	JUNTA TORICA 2,62X10,78 VITON 70
	4	ZJ0067545	1	VITE TEF M6X1X95 CH8	SCREW TEF M6X1X95 CH8	VIS TEF M6X1X95 CH8	SCHRAUBE TEF M6X1X95 CH8	TORNILLO TEF M6X1X95 CH8
	5	8000A8040	1	DISTANZIALE 37 MM	SPACER 37 MM	ENTRETOISE 37 MM	ABSTANDHALTER 37 MM	DISTANCIADOR 37 MM
	6	8B00A0702	1	DISTANZIALE 46 MM	SPACER 46 MM	ENTRETOISE 46 MM	ABSTANDHALTER 46 MM	DISTANCIADOR 46 MM
	7	800028929	1	ANELLO O-RING 4081	O-RING 4081	JOINT TORIQUE 4081	O-RING 4081	JUNTA TORICA 4081
	8	8000A0528	3	TAMPONE SERBATOIO	CUSHION, FUEL TANK	TAMPON APPUI RESERVOIR	DAEMPFER TANKAUFLAGE	TAMPON APOYO DEPOSITO
	9	60ND02510	2	VITE BRUGOLA M6X25	BOLT.HEXAGON SOCKET HEAD M6X25	VIS TETE HEXAGONALE CREUSE M6X25	INNENSECHSKANTSCHRAUBE M6X25	TORNILLO, ALLEN M6X25
	10	8000A0680	2	DISTANZIALE 10,5X6,5X13,5	SPACER 10.5X6.5X13.5	ENTRETOISE 10,5X6,5X13,5	ABSTANDHALTER 10,5X6,5X13,5	DISTANCIADOR 10,5X6,5X13,5
	11	8000B1057	1	TAPPO SERBATOIO CARBURANTE	CAP SET, FUEL TANK	BOUCHON RESERVOIR CARBURANT	VERSCHLUSS, KRAFTSTOFFTANK	TAPON DEPOSITO CARBURANTE
	12	8000A4562	1	GUARNIZIONE TAPPO SERBATOIO	GASKET, CAP	JOINT, BOUCHON RESERVOIR	DICHTUNG, VERSCHLUSSKAPPE	JUNTA TAPON DEPOSITO
	13	8T0068873	1	TUBO CARBURANTE 300 MM	HOSE, FUEL 300 MM	TUYAU CARBURANT 300 MM	KRAFTSTOFFSCHLAUCH 300 MM	MANGUERA CARBURANTE 300 MM
	14	8000H4027	1	TUBO CARBURANTE	HOSE, FUEL	TUYAU CARBURANT	KRAFTSTOFFSCHLAUCH	MANGUERA CARBURANTE
	15	80A042349	2	FASCETTA	CLAMP	COLLIER	KLAMMER	ABRAZADERA
	16	80A0A5978	1	PROTEZIONE RADIATORE DESTRO	COVER, RADIATOR, RH	PROTECTION RADIATEUR DROIT	KUHLERSCHUTZ, RECHTS	PROTECCION RADIADOR DERECHO
	17	80A0A5977	1	PROTEZIONE RADIATORE SINISTRO	COVER, RADIATOR, LH	PROTECTION RADIATEUR GAUCHE	KUHLERSCHUTZ, LINKS	PROTECCION RADIADOR IZQUERDO
	18	8A00A8423	6	VITE FLANGIATA M6X12	BOLT, FLANGE M5X12	VIS A EMBASE M5X12	GEFLANSCHSCHRAUBE M5X12	TORNILLO CON VALONA M5X12
	19	Z00036467	4	VITE TCIC M6X1X10	SCREW TCIC M6X1.00X10	VIS TCIC M6X1,00X10	SCHRAUBE TCIC M6X1,00X10	TORNILLO TCIC M6X1,00X10
	20	800045495	4	BOCCOLA	BUSH	DOUILLE	BUCHSE	BUJE
SMS125/11	21	8000H2343	1	CONVOGLIATORE SINISTRO	COVER, RADIATOR, LH	OUIE RADIATEUR GAUCHE	LINKES LEITBLECH	DEFLECTOR AIRE IZQUERDO
TE125/11	21	8000H2067	1	CONVOGLIATORE SINISTRO	COVER, RADIATOR, LH	OUIE RADIATEUR GAUCHE	LINKES LEITBLECH	DEFLECTOR AIRE IZQUERDO
SMS125/11	22	8000H2344	1	CONVOGLIATORE DESTRO	COVER, RADIATOR, RH	OUIE RADIATEUR DROIT	RECHTES LEITBLECH	PROTECTOR RADIADOR DERECHO
TE125/11	22	8000H2066	1	CONVOGLIATORE DESTRO	COVER, RADIATOR, RH	OUIE RADIATEUR DROIT	RECHTES LEITBLECH	PROTECTOR RADIADOR DERECHO
	23	U00046893	4	DADO ELASTICO M6X1	CLIP NUT M6X1	JONC M6X1	KLEMME M6X1	PRESILLA M6X1
	24	U00060873	4	DADO ELASTICO M6X1	NUT SPRING M6X1	ECROU ELASTIQUE M6X1	FEDERMUTTER M6X1	TUERCA ELASTICA M6X1

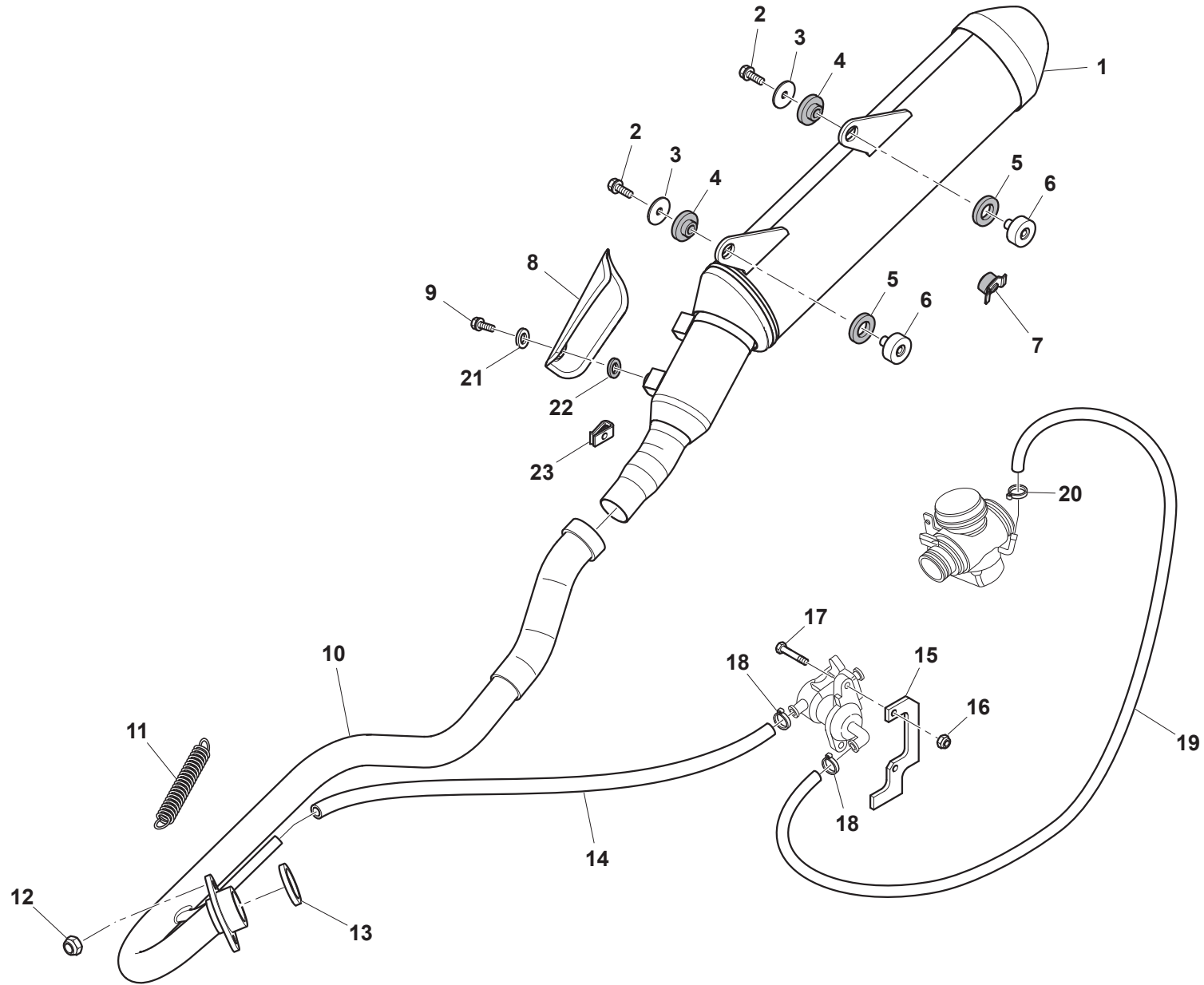

## SCARICO - EXHAUST SYSTEM TUYAU D'ÉCHAPPEMENT - AUSPUFFROHR TUBO DE ESCAPE

Note Notes Marke Notas	Pos. No. N. Index Pos.	N. Cod. Code No. Nr. Code Code Nr N. Cod.	Q.tà Q.ty Q.te M.ge C.ad	DENOMINAZIONE	NAME	DESIGNATION	BESHREIBUNG	DENOMINACION
	1	8000H4051	1	SILENZIATORE	SILENCER, EXHAUST	SILENCIEUX	SCHALLDAEMPFER	SILENCIADOR
	2	ZA0067545	2	VITE TEF M6X1,00X35 CH8	SCREW TEF M6X1.00X35 CH8	VIS TEF M6X1,00X35 CH8	SCHRAUBE TEF M6X1,00X35 CH8	TORNILLO TEF M6X1,00X35 CH8
	3	151374301	2	RONDELLA 28X7,2X2	WASHER 28X7.2X2	RONDELLE 28X7,2X2	SCHEIBE 28X7,2X2	ARANDELA 28X7,2X2
	4	151341401	2	RONDELLA IN GOMMA 30X1,5X5	WASHER, RUBBER 30X1.5X5	RONDELLE EN CAOUTCHOUC 30X1,5X5	GUMMISCHEIBE 30X1,5X5	ARANDELA GOMA 30X1,5X5
	5	151410702	2	SILENTBLOCK	DAMPER	SILENTBLOC	SCHWINGUNGSDAEMPFER	CASQUILLO ELASTICO
	6	8B0070379	2	DISTANZIALE 28X6,5X9,5X24	SPACER 28X6.5X9.5X24	ENTRETOISE 28X6,5X9,5X24	ABSTANDHALTER 28X6,5X9,5X24	DISTANCIADOR 28X6,5X9,5X24
	7	800048802	1	GOMMINO	GROMMET	CAOUTCHOUC	GUMMITEILE	GOMA
	8	8000H4168	1	PROTEZIONE SILENZIATORE	GUARD, SILENCER	PROTECTION SILENCIEUX	SCHALLDAEMPFFERSCHUTZ	PROTECCION SILENCIADOR
	9	Z00055703	2	VITE TCEI M6X1X14	SCREW TCEI M6X1X14	VIS TCEI M6X1X14	SCHRAUBE TCEI M6X1X14	TORNILLO TCEI M6X1X14
	10	8000H4053	1	COLLETTORE SCARICO	EXHAUST MANIFOLD	COLLECTEUR ECHAPPEMENT	AUSPUFFKRUEMMER	TUBERIA ESCAPE
	11	8000A1239	1	MOLLA SCARICO	SPRING, EXHAUST PIPE	RESSORT ANCRAGE TUYAU ECHAPPEMENT	FEDER AUSPUFFROHRBEFESTIGUNG	MUELLE ANCLAJE TUBERIA ESCAPE
	12	Y00043928	2	DADO AUTOBLOCCANTE M8X1,25 H8 CH12	NUT, SELF LOCKING M8X1.25	ECROU AUTOBLOQUANT M8X1,25	SELBSTSPERRENDE MUTTER M8X1,25	TUERCA AUTOBLOQUEANTE M8X1,25
	13	8000H3525	1	GUARNIZIONE COLLETTORE SCARICO	GASKET, EXHAUST MANIFOLD	JOINT TUYAU ECHAPPEMENT	DICHTUNG, ABLASSLEITUNG	JUNTA TUBERIA ESCAPE
	14	8000H4023	1	TUBO	HOSE	TUYAU	SCHLAUCH	MANGUERA
	15	8000H3510	1	SUPPORTO VALVOLA ARIA SECONDARIA	BRACKET, VALVE SECONDARY AIR	SUPPORT SOUPAPE AIR SECONDAIRE	HALTER SEKUNDAERE LUFT VENTIL	SOPORTE VALVULA AIRE SECUNDARIA
	16	Z00044240	2	DADO AUTOBLOCCANTE M6X1 CH10	NUT, SELF LOCKING M6X1 CH10	ECROU AUTOBLOQUANT M6X1 CH10	SELBSTSPERRENDE MUTTER M6X1 CH10	TUERCA AUTOBLOQUEANTE M6X1 CH10
	17	ZPA067545	2	VITE TEF M6X1X22 CH8	SCREW TEF M6X1X22 CH8	VIS TEF M6X1X22 CH8	SCHRAUBE TEF M6X1X22 CH8	TORNILLO TEF M6X1X22 CH8
	18	8M0092249	2	FASCETTA CLIC R96 14,5 MM	CLAMP CLIC R96 14.5 MM	COLLIER CLIC R96 14,5 MM	KLAMMER CLIC R96 14,5 MM	ABRAZADERA CLIC R96 14,5 MM
	19	8000H4024	1	TUBO	HOSE	TUYAU	SCHLAUCH	MANGUERA
	20	800056460	1	ANELLO ELASTICO	SPRING RING	ANNEAU ARRET	SPRENGRING	ANILLO RETENCION
	21	62ND15778	2	RONDELLA 12X6,4X0,5 MM	WASHER 12X6.4X0.5 MM	RONDELLE 12X6,4X0,5 MM	SCHEIBE 12X6,4X0,5 MM	ARANDELA 12X6,4X0,5 MM
	22	800035112	2	RONDELLA ISOLANTE 14X5,5X2 MM	INSULATING WASHER 14X5.5X2 MM	RONDELLE ISOLANTE 14X5,5X2 MM	ISOLIERSCHEIBE 14X5,5X2 MM	ARANDELA AISLANTE 14X5,5X2 MM
	23	U00046893	2	DADO ELASTICO M6X1	CLIP NUT M6X1	JONC M6X1	KLEMME M6X1	PRESILLA M6X1

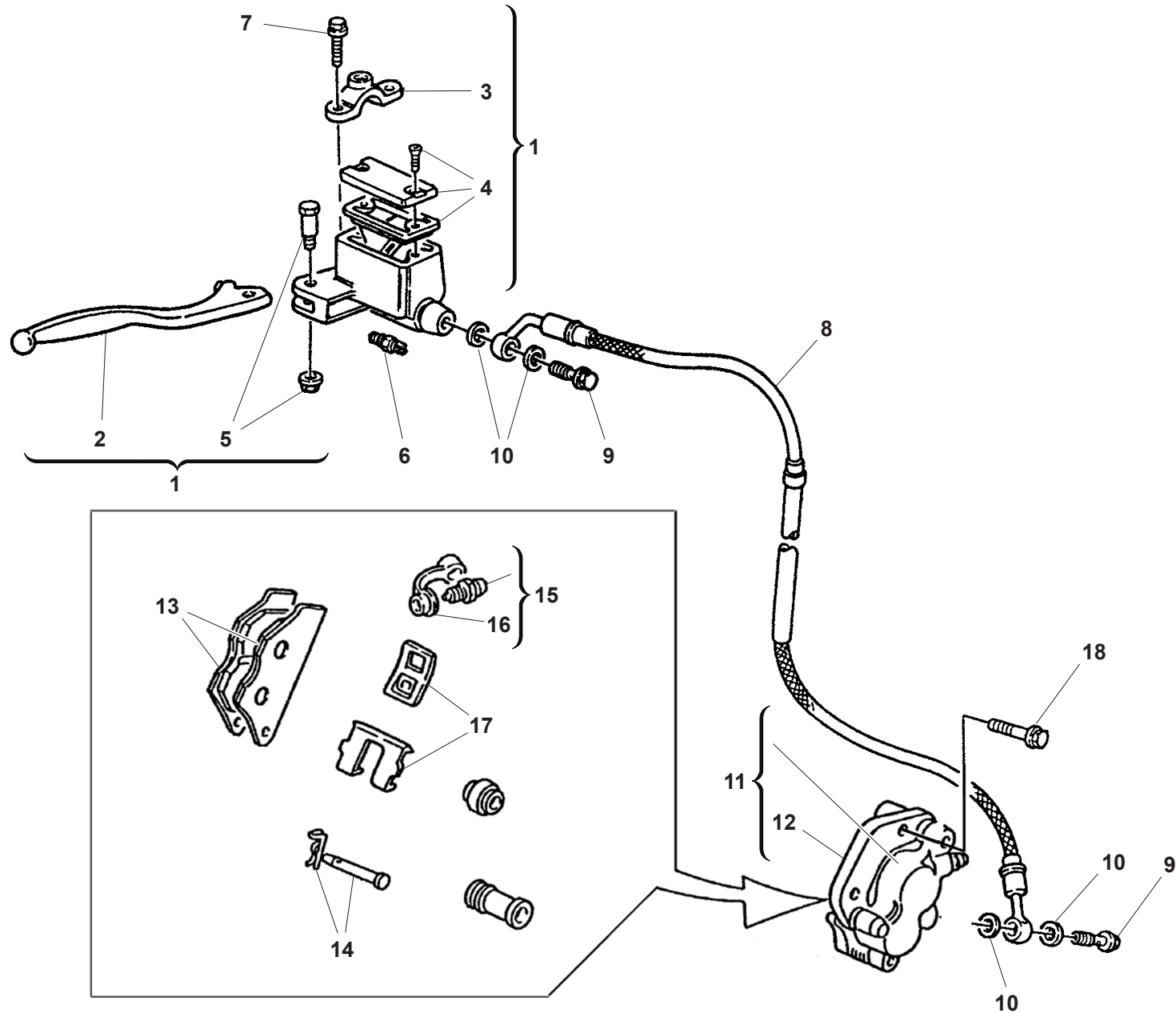

## FRENO IDRAULICO ANTERIORE - FRONT HYDRAULIC BRAKE FREIN HYDRAULIQUE AVANT - VORDERBREMSE FRENO HIDRAULICO DELANTERO

Note Notes Marke Notas	Pos. No. N. Index Pos.	N. Cod. Code No. Nr. Code Code Nr. N. Cod.	Q.tà Q.ty Q.te M.ge C.ad	DENOMINAZIONE	NAME	DESIGNATION	BESHREIBUNG	DENOMINACION
	1	8A0076024	1	POMPA FRENO ANTERIORE	CYLINDER, FRONT MASTER	MAITRE CYLINDRE FREIN AVANT	HAUPTZYLINDER, VORNE	BOMBA FRENO DELANTERO
	2	800079067	1	LEVA FRENO ANTERIORE	LEVER, FRONT BRAKE	LEVIER FREIN AVANT	BREMSHEBEL VORNE	PALANCA FRENO DELANTERO
	3	800079068	1	CAVALLOTTO POMPA FRENO	BRACKET, MASTER CYLINDER	BRIDE MAITRE CYLINDRE	KONSOLE, HAUPTBREMSZYLINDER	BRIDA BOMBA FRENO
	4	800079069	1	COPERCHIO VASCHETTA LIQUIDO FRENI	COVER MASTER CYLINDER	COUVERCLE RESERVOIR LIQUIDE FREIN	VERSCHLUSS BREMSFLUESSIGKEITANK	TAPON DEPOSITO LIQUIDO FRENOS
	5	800079070	1	PERNO LEVA FRENO	BOLT, HANDLE LEVER PIVOT	PIVOT LEVIER FREIN	HEBELSCHRAUBE KPL.	PERNO PALANCA FRENO
	6	8000H2099	1	INTERRUTTORE STOP ANTERIORE	SWITCH, FRONT STOP	INTERRUPTEUR STOP AVANT	STOPSCHALTER VORNE	INTERRUPTOR STOP DELANTERO
	7	Z00062729	2	VITE TEF M6X1X25 CH8	SCREW TEF M6X1X25 CH8	VIS TEF M6X1X25 CH8	SCHRAUBE TEF M6X1X25 CH8	TORNILLO TEF M6X1X25 CH8
	8	8B0076025	1	TUBO OLIO FRENO ANTERIORE	HOSE, FRONT BRAKE	TUYAU FREIN AVANT	VORDERBREMSSCHLAUCH	MANGUERA FRENO DELANTERO
	9	U00057155	2	VITE RACCORDO TUBO M10X1,00X19	BOLT, BRAKE HOSE M10X1.00X19	VIS FIXATION TUYAU M10X1.00X19	FIXIERSCHRAUBE BREMSCHLAUCH M10X1.00X19	TORNILLO MANGUERA ACEITE M10X1X19
	10	800021480	4	RONDELLA 14X10,2X1 MM	WASHER 14X10.2X1 MM	RONDELLE 14X10,2X1 MM	SCHEIBE 14X10,2X1 MM	ARANDELA 14X10,2X1 MM
SMS125/11	11	8000H4180	1	PINZA FRENO ANTERIORE	CALIPER, FRONT BRAKE	ETRIER FREIN AVANT	BREMSSATTEL, VORNE	PINZA FRENO DELANTERO
TE125/11	11	800099674	1	PINZA FRENO ANTERIORE	CALIPER, FRONT BRAKE	ETRIER FREIN AVANT	BREMSSATTEL, VORNE	PINZA FRENO DELANTERO
	12	800099859	1	SUPPORTO PINZA FRENO ANTERIORE	CARRIER SET, FR BRAKE	SUPPORT ETRIER FREIN AVANT	HALTERUNG, VORNEBREMSESATTEL	SOPORTE PINZA FRENO DELANTERO
SMS125/11	13	8000H4701	1	COPPIA PASTIGLIE FRENO ANTERIORE	PADS SET, FRONT BRAKE	JEU PLAQUETTES FREIN AVANT	VORNEBREMSBELAEGESATZ	JUEGO PASTILLAS FRENO DELANTERO
TE125/11	13	800096934	1	COPPIA PASTIGLIE FRENO ANTERIORE	PADS SET, FRONT BRAKE	JEU PLAQUETTES FREIN AVANT	VORNEBREMSBELAEGESATZ	JUEGO PASTILLAS FRENO DELANTERO
	14	8000A0932	1	GRUPPO REVISIONE PERNI PASTIGLIE FRENO	PAD PINS OVERHAUL SET	GROUPE REVISION PIVOTS PLAQUETTE	BREMSBELAEGEN EBERHOLUNGSGRUPPE	GRUPO REVISION PERNO PASTILLAS FRENO
	15	8000A0931	1	VITE SPURGO PINZA FRENO	BLEED SCREW KIT	VIS VIDANGE ETRIER FREIN	SCHRAUBE, BREMSATTEL ABLASS	TORNILLO PURGA PINZA FRENO
	16	800053259	1	CAPPUCCIO VITE SPURGO	CAP, BLEEDER SCREW	CAPUCHON VIS RENIFLARD	ENTLUEFTUNGSKAPPE	CAPUCHON TORNILLO PURGA PINZA
	17	800079065	1	MOLLETTE PASTIGLIE FRENO	SUPPORT, PAD	RESSORT PLAQUETTE FREIN	FEDER, BREMSSEHEIBE	MUELLE PASTILLAS
	18	Z00062733	2	VITE TE M8X1,25X35 CH12	SCREW TE M8X1.25X35 CH12	VIS TE M8X1,25X35 CH12	SCHRAUBE TE M8X1,25X35 CH12	TORNILLO TE M8X1,25X35 CH12

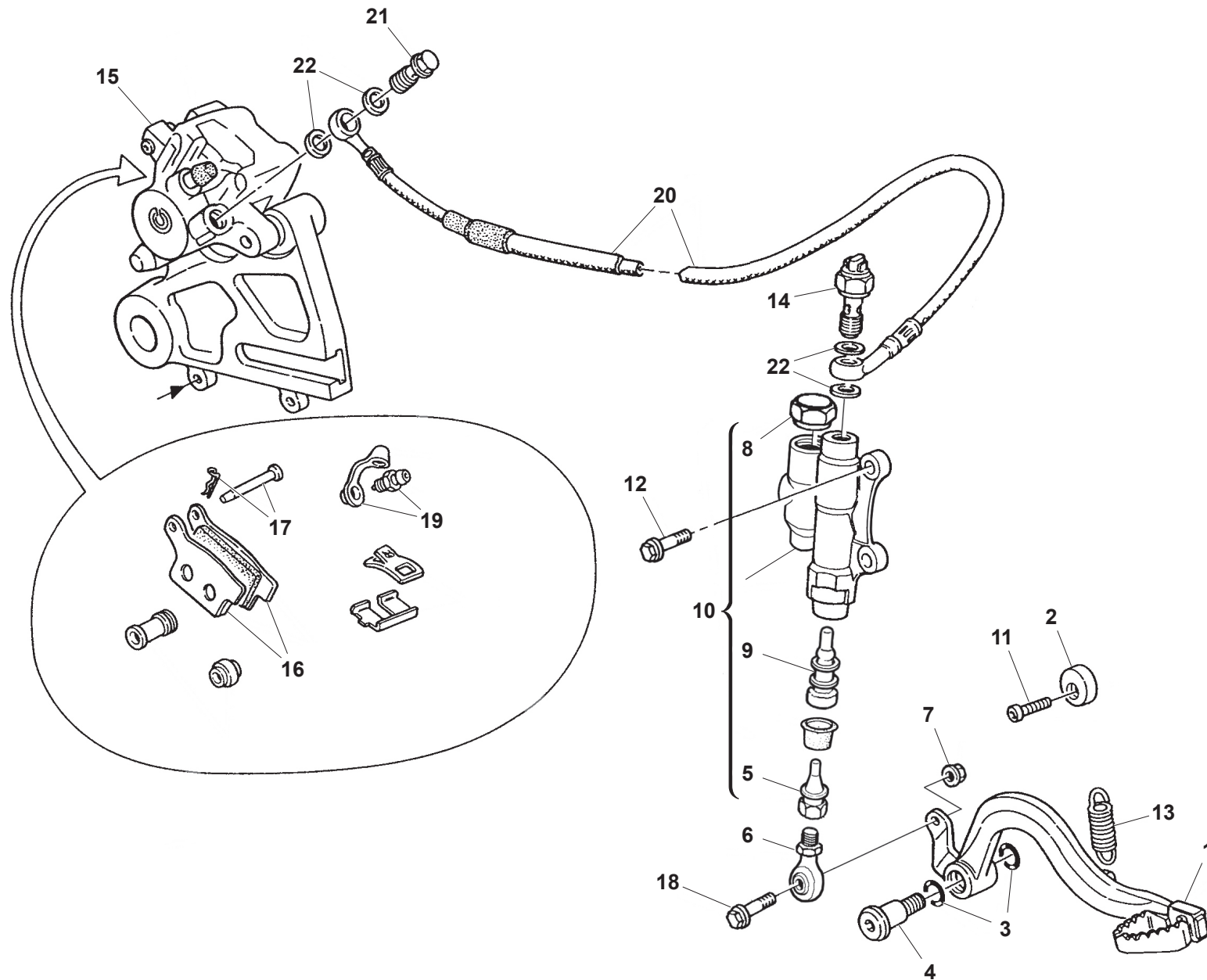



**FRENO IDRAULICO POSTERIORE - REAR HYDRAULIC BRAKE**  
**FREIN HYDRAULIQUE ARRIERE - HINTERBREMSE**  
**FRENO HIDRAULICO TRASERO**

Note Notes Marke Notas	Pos. No. N. Index Pos.	N. Cod. Code No. Nr. Code Code Nr N. Cod.	Q.tà Q.ty Q.te M.ge C.ad	DENOMINAZIONE	NAME	DESIGNATION	BESHREIBUNG	DENOMINACION
	1	8000H3866	1	PEDALE FRENO	PEDAL, BRAKE	PEDALE FREIN	FUSSBREMSPEDAL	PEDAL FRENO
	2	8A0069125	1	ECCENTRICO PEDALE FRENO	ECCENTRIC, ADJUSTMENT BRAKE PEDAL	EXCENTRIQUE REGLAGE PEDAL FREIN	REGULIEREXZENTIKER BREMSE PEDAL	EXCENTRICO REGULACION PEDAL FRENO
	3	800022551	2	ANELLO O-RING 2056 14X1,78	O-RING 2056 14X1.78	JOINT TORIQUE 2056 14X1,78	O-RING 2056 14X1,78	JUNTA TORICA 2056 14X1,78
	4	Y00055902	1	VITE TPEI M10X1,25X16	SCREW TPEI M10X1.25X16	VIS TPEI M10X1,25X16	SCHRAUBE TPEI M10X1,25X16	TORNILLO TPEI M10X1,25X16
	5	8000A7635	1	PUNTALINO POMPA FRENO	ROD-PUSH, MASTER CYLINDER	BARRE PRESSION	DRUCKSTANGE	VARILLA PRESION
	6	764010002	1	SNODO SFERICO DESTRO	BALL JOINT, RH	JOINT A ROTULE, DROIT	KUGELGELENK, RECHTS	ROTULA ESFERICA DERECHA
	7	61ND15062	1	DADO M6X1H4 CH10	NUT M6X1 H4 CH10	ECROU M6X1 H4 CH10	MUTTER M6X1 H4 CH10	TUERCA M6X1 H4 CH10
	8	8000A9447	1	TAPPO POMPA FRENO POSTERIORE	PLUG CYLINDER, REAR MASTER	BOUCHON MAITRE CYLINDRE FREIN ARRIERE	VERSCHLUSS HAUPTZYLINDER, HINTEN	TAPON BOMBA FRENO TRASERO
	9	8000A9448	1	ASTINA POMPA FRENO	ROD, BRAKE CYLINDER	TIGE MAITRE CYLINDRE	HAUPTZYLINDERSTANGE	VARILLA BOMBA FRENO
	10	8000A7633	1	POMPA FRENO POSTERIORE	CYLINDER, REAR MASTER	MAITRE CYLINDRE FREIN ARRIERE	HAUPTZYLINDER, HINTEN	BOMBA FRENO TRASERO
	11	Y00055241	1	VITE TSEI M6X1X20 CH5	SCREW TSEI M6X1X20 CH5	VIS TSEI M6X1X20 CH5	SCHRAUBE TSEI M6X1X20 CH5	TORNILLO TSEI M6X1X20 CH5
	12	ZH0067545	2	VITE TEF M6X1X12 CH8	SCREW TEF M6X1X12 CH8	VIS TEF M6X1X12 CH8	SCHRAUBE TEF M6X1X12 CH8	TORNILLO TEF M6X1X12 CH8
	13	8A0055903	1	MOLLA PEDALE FRENO	SPRING, BRAKE PEDAL	RESSORT PEDALE FREIN	FEDER, BREMSPEDAL	MUELLE PEDAL FRENO
	14	800094849	1	INTERRUTTORE STOP POSTERIORE	SWITCH, REAR BRAKE	INTERRUPTEUR STOP ARRIERE	HINTEN STOPSCHALTER	INTERRUPTOR STOP TRASERO
	15	800076032	1	PINZA FRENO POSTERIORE	CALIPER, REAR BRAKE	ETRIER FREIN ARRIERE	HINTEN BREMSSATTEL	PINZA FRENO TRASERA
	16	8000A9231	1	COPPIA PASTIGLIE FRENO POSTERIORE	PADS SET, REAR BRAKE	JEU PLAQUETTES FREIN ARRIERE	HINTERBREMSBELAEGESATZ	JUEGO PASTILLAS FRENO TRASERO
	17	800087152	1	PERNO PASTIGLIE FRENO	PIN BRAKE PAD	PIVOT PLAQUETTE FREIN	BOLZEN, BREMSESCHEIBEN	PERNO PASTILLAS FRENO
	18	Z00062727	1	VITE TE M6X1X16 CH8	SCREW TE M6X1X16 CH8	VIS TE M6X1X16 CH8	SCHRAUBE TE M6X1X16 CH8	TORNILLO TE M6X1X16 CH8
	19	800060404	1	VITE SPURGO PINZA FRENO	BLEED SCREW KIT	VIS VIDANGE ETRIER FREIN	SCHRAUBE, BREMSSATTEL ABLASS	TORNILLO PURGA PINZA FRENO
	20	800078164	1	TUBO FRENO POSTERIORE	HOSE, REAR BRAKE	TUYAU FREIN ARRIERE	BREMSSCHLAUCH HINTEN	MANGUITO FRENO TRASERO
	21	800057155	1	VITE RACCORDO TUBO M10X1,00X19	BOLT, BRAKE HOSE M10X1.00X19	VIS FIXATION TUYAU M10X1,00X19	FIXIERSCHRAUBE M10X1,00X19	TORNILLO FIJACION MANGUERA M10X1,00X19
	22	800021480	4	RONDELLA 14X10,2X1 MM	WASHER 14X10.2X1 MM	RONDELLE 14X10,2X1 MM	SCHEIBE 14X10,2X1 MM	ARANDELA 14X10,2X1 MM

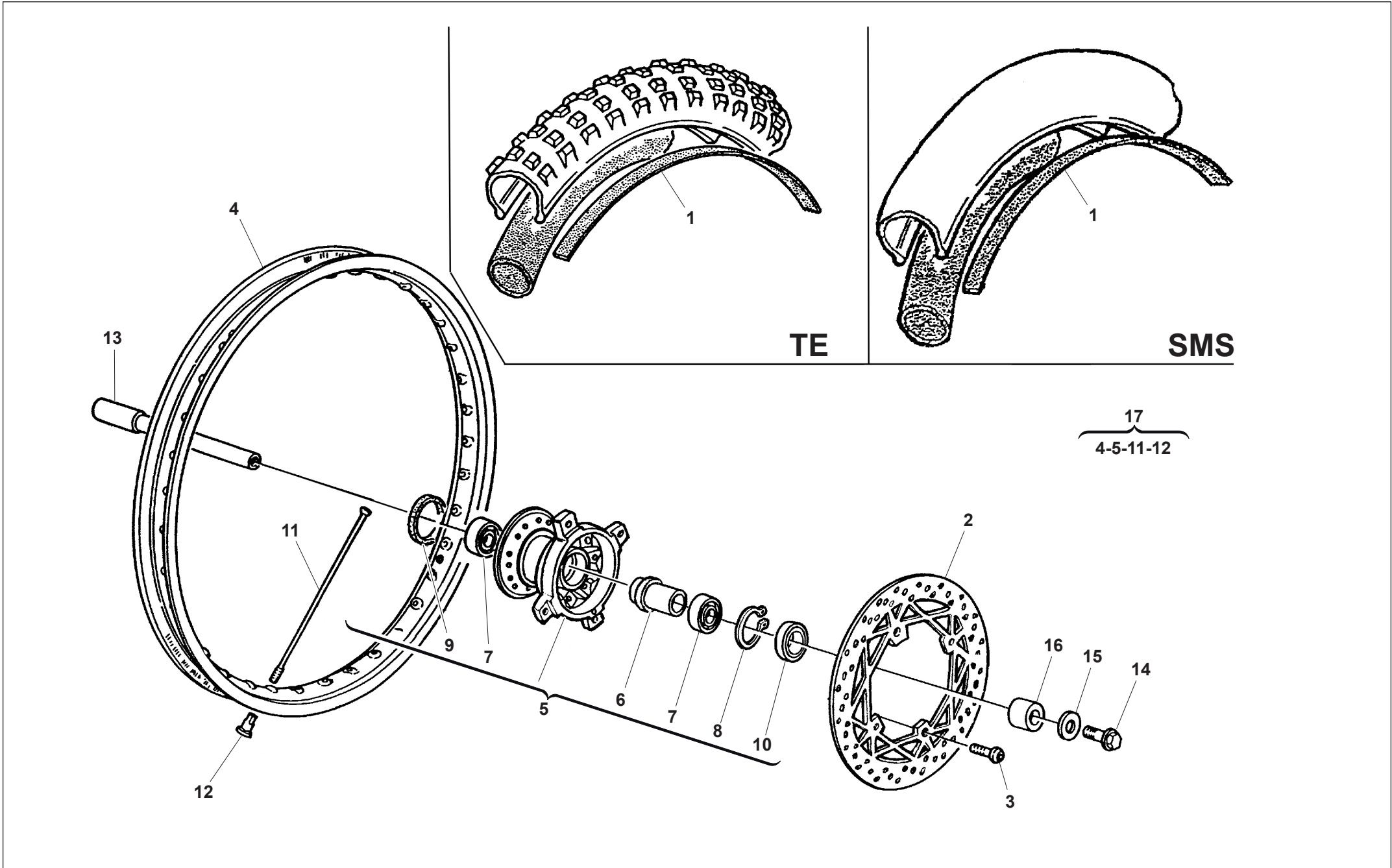



# TE-SMS4 125/2011

**RUOTA ANTERIORE - FRONT WHEEL**  
**ROUE AV. - VORTERRAD**  
**RUEDA DELANTERA**

TAVOLA  
DRAWING  
TABLE  
BILD  
TABLA

# 32

Note Notes Marke Notas	Pos. No. N. Index Pos.	N. Cod. Code No. Nr. Code Code Nr. N. Cod.	Q.tà Q.ty Q.te M.ge C.ad	DENOMINAZIONE	NAME	DESIGNATION	BESHREIBUNG	DENOMINACION
SMS125/11	1	800043303	1	FASCIA SALVACAMERA	PROTECTOR, INNER TUBE	FOND JANTE	FELGENBAND	PROTECTOR CAMARA
TE125/11	1	800013346	1	FASCIA SALVACAMERA	PROTECTOR, INNER TUBE	FOND JANTE	FELGENBAND	PROTECTOR CAMARA
	2	800099632	1	DISCO FRENO ANTERIORE	DISC, FRONT BRAKE	DISQUE FREIN AVANT	BREMSSSCHEIBE, VORNE	DISCO FRENO DELANTERO
	3	Y00055241	4	VITE TSEI M6X1X20 CH5	SCREW TSEI M6X1X20 CH5	VIS TSEI M6X1X20 CH5	SCHRAUBE TSEI M6X1X20 CH5	TORNILLO TSEI M6X1X20 CH5
SMS125/11	4	8000H3138	1	CERCHIO RUOTA ANTERIORE 2,50X17	RIM, FRONT WHEEL 2.50X17	JANTE ROUE AVANT 2,50X17	FELGE, VORDERRAD 2,50X17	LLANTA RUEDA DELANTERA 2,50X17
TE125/11	4	8000H3813	1	CERCHIO RUOTA ANTERIORE 1,6X21	RIM, FRONT WEHEL 1.6X21	JANTE ROUE AVANT 1,6X21	FELGE, VORDERRAD 1,6X21	LLANTA RUEDA DELANTERA 1,6X21
	5	8000A7201	1	MOZZO RUOTA ANTERIORE	HUB, FRONT WHEEL	MOYEU ROUE AVANT	RADNABE, VORNE	CUBO RUEDA DELANTERA
	6	8000A7217	1	DISTANZIALE INTERNO CUSCINETTI	SPACER, HUB BEARING	ENTRETOISE INTERNE ROULEMENT	KUGELLAGER INNEREABSTANDHALTER	DISTANCIADOR INTERIOR COJINETE
	7	800039651	2	CUSCINETTO A SFERE 6004 2RS	BALL BEARING 6004 2RS	ROULEMENT A BILLES 6004 2RS	KUGELLAGER 6004 2RS	COJINETE DE BOLAS 6004 2RS
	8	66N021270	1	ANELLO SEEGER INTERNO 42MM DIN472	CIRCLIP 42MM DIN472	CIRCLIP 42MM DIN472	SEEGERRING 42MM DIN472	ANILLO SEEGER 42MM DIN472
	9	8B0068259	1	PARAOLIO 25X45X7	SEAL, OIL 25X45X7	BAGUE D'ETANCHEITE 25X45X7	WELLENDICHRING 25X45X7	RETEN DE ACEITE 25X45X7
	10	800088889	1	PARAPOLVERE	DUST SEAL	PARE POUSSIERE	STAUBDICHTUNG	GUARDAPOLVO
SMS125/11	11	8A0094754	18	RAGGIO RUOTA ANTERIORE LATO DISCO 177 MM	SPOKE, FRONT WHEEL DISC SIDE 177 MM	RAYON ROUE AVANT COTE DISQUE 177 MM	SPEICHE, VORDERRAD SCHEIBE SEITE 177 MM	RADIO RUEDA DELANTERA LATO DISCO 177 MM
SMS125/11	11	800094754	18	RAGGIO RUOTA ANTERIORE 174 MM	SPOKE, FRONT WHEEL 174 MM	RAYON ROUE AVANT 174 MM	SPEICHE, VORDERRAD 174 MM	RADIO RUEDA DELANTERA 174 MM
TE125/11	11	800092693	36	RAGGIO RUOTA ANTERIORE	SPOKE, FRONT WHEEL	RAYON ROUE AVANT	SPEICHE, VORDERRAD	RADIO RUEDA DELANTERA
	12	69N429004	36	NIPPLO RAGGIO	NIPPLE, SPOKE	ECROU RAYON	NIPPEL, SPEICHE	TUERCA RADIO
	13	800075042	1	PERNO RUOTA ANTERIORE	AXLE, FRONT WHEEL	AXE ROUE AVANT	VORDERRADACHSE	EJE RUEDA DELANTERA
	14	Z00048773	1	VITE TE M10X1,5X20 CH15	SCREW TE M10X1,5X20 CH15	VIS TE M10X1,5X20 CH15	SCHRAUBE TE M10X1,5X20 CH15	TORNILLO TE M10X1,5X20 CH15
	15	Z00048772	1	RONDELLA PIANA 24X10,5X2	WASHER, PLAIN 24X10,5X2	RONDELLE, PLATE 24X10,5X2	UNTERLEGSCHEIBE 24X10,5X2	ARANDELA PLANA 24X10,5X2
	16	8C0092792	1	DISTANZIALE 20 MM	SPACER B 20 MM	ENTRETOISE B 20 MM	ABSTANDHALTER B 20 MM	SEPARADOR B 20 MM
SMS125/11	17	8000H6387	1	RUOTA ANTERIORE	WHEEL, FRONT	ROUE AVANT	VORDERRAD	RUEDA DELANTERA
TE125/11	17	8000H6389	1	RUOTA ANTERIORE	WHEEL, FRONT	ROUE AVANT	VORDERRAD	RUEDA DELANTERA

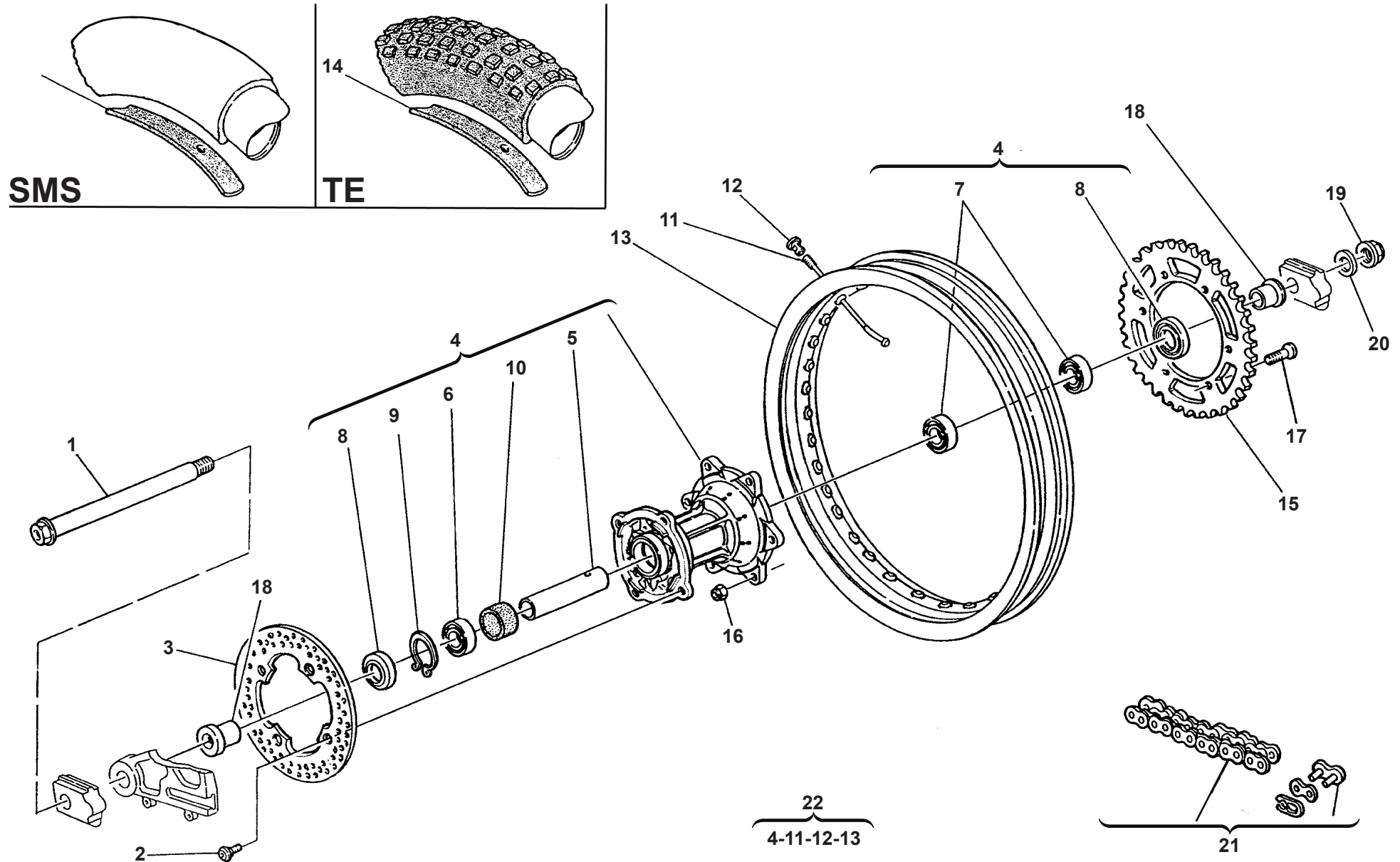

## RUOTA POSTERIORE - REAR WHEEL ROUE ARRIERE - HINTERRAD RUEDA TRASERA

Note Notes Marke Notas	Pos. No. Index Pos.	N. Cod. Code No. Nr. Code Code Nr N. Cod.	Q.tà Q.ty Q.te M.ge C.ad	DENOMINAZIONE	NAME	DESIGNATION	BESHREIBUNG	DENOMINACION
	1	8E0064938	1	PERNO RUOTA POSTERIORE	AXLE, REAR WHEEL	AXE ROUE ARRIERE	HINTERRADACHSE	EJE RUEDA TRASERA
	2	800055878	4	VITE TPEI M6X1X11	SCREW TPEI M6X1.00X11	VIS TPEI M6X1,00X11	SCHRAUBE TPEI M6X1,00X11	TORNILLO TPEI M6X1,00X11
	3	800088887	1	DISCO FRENO POSTERIORE	DISC REAR BRAKE	DISQUE FREIN ARRIERE	BREMSSCHEIBE, HINTEN	DISCO FRENO TRASERO
	4	8000A7202	1	MOZZO RUOTA POSTERIORE	HUB, REAR WHEEL	MOYEU ROUE ARRIERE	RADNABE, HINTEN	CUBO RUEDA TRASERA
	5	8000A7223	1	DISTANZIALE INTERNO CUSCINETTI	SPACER, HUB BEARING	ENTRETOISE INTERNE ROULEMENT	KUGELLAGER INNEREABSTANDHALTER	DISTANCIADOR INTERIOR COJINETE
	6	8B0026846	1	CUSCINETTO A SFERE 25X47X16	BEARING, BALL 25X47X16	ROULEMENT A BILLES 25X47X16	KUGELLAGER 25X47X16	COJINETE DE BOLAS 25X47X16
	7	8A0026846	2	CUSCINETTO A SFERE 6005	BEARING, BALL 6005	ROULEMENT A BILLES 6005	KUGELLAGER 6005	COJINETE DE BOLAS 6005
	8	800089572	2	PARAOLIO 32X47X7	OIL SEAL 32X47X7	BAGUE D'ETANCHEITE 32X47X7	WELLENDICHTRING 32X47X7	RETEN DE ACEITE 32X47X7
	9	66N021272	1	ANELLO ELASTICO 50,5 MM	CIRCLIP 50.5 MM	CIRCLIP 50,5 MM	SPRENGRING 50,5 MM	ANILLO ELASTICO 50,5 MM
	10	800092797	1	DISTANZIALE	SPACER	ENTRETOISE	ABSTANDHALTER	DISTANCIADOR
SMS125/11	11	800094757	18	RAGGIO RUOTA POSTERIORE LATO DISCO	REAR WHEEL SPOKE, DISC SIDE	RAYON ROUE ARRIERE COTE DISQUE	HINTERRADSPICHE SCHEIBE SEITE	RADIO RUEDA TRASERA LATO DISCO
SMS125/11	11	800095341	18	RAGGIO RUOTA POSTERIORE LATO CORONA	REAR WHEEL SPOKE, SPROCKET SIDE	RAYON ROUE ARRIERE COTE COURONNE	HINTERRADSPICHE ZAHNKETTENRAD SEITE	RADIO RUEDA TRASERA LATO CORONA
TE125/11	11	800092703	36	RAGGIO RUOTA POSTERIORE	SPOKE, REAR WHEEL	RAYON ROUE ARRIERE	SPEICHE, HINTENRAD	RADIO RUEDA TRASERA
	12	69N429005	36	NIPPLO RAGGIO	NIPPLE, SPOKE	ECROU RAYON	NIPPEL, SPEICHE	TUERCA RADIO
SMS125/11	13	8000H3139	1	CERCHIO RUOTA POSTERIORE 3,50X17	RIM, REAR WHEEL 3.50X17	JANTE ROUE ARRIERE 3,50X17	FELGE, HINTENRAD 3,50X17	LLANTA RUEDA TRASERA 3,50X17
TE125/11	13	8000H3814	1	CERCHIO RUOTA POSTERIORE 2,15X18	RIM, REAR WHEEL 2.15X18	JANTE ROUE ARRIERE 2,15X18	FELGE, HINTENRAD 2,15X18	LLANTA RUEDA TRASERA 2,15X18
SMS125/11	14	8B0082879	1	FASCIA SALVACAMERA	PROTECTOR, INNER TUBE	FOND JANTE	FELGENBAND	PROTECTOR CAMARA
TE125/11	14	800001688	1	FASCIA SALVACAMERA	PROTECTOR, INNER TUBE	FOND JANTE	FELGENBAND	PROTECTOR CAMARA
SMS125/11	15	8000H3140	1	CORONA Z54	REAR SPROCKET T54	COURONNE D54	ZAHNKETTENRAD Z54	CORONA D54
TE125/11	15	8000H3864	1	CORONA Z59	REAR SPROCKET T59	COURONNE D59	ZAHNKETTENRAD Z59	CORONA D59
	16	Y00043928	6	DADO AUTOBLOCCANTE M8X1,25 H8 CH12	NUT, SELF LOCKING M8X1.25	ECROU AUTOBLOQUANT M8X1,25	SELBSTSPERRENDE MUTTER M8X1,25	TUERCA AUTOBLOQUEANTE M8X1,25
	17	YC0040796	6	VITE TSEI M8X1,25X20	SCREW TSEI M8X1.25X20	VIS TSEI M8X1,25X20	SCHRAUBE TSEI M8X1,25X20	TORNILLO TSEI M8X1,25X20
	18	8A0092413	2	DISTANZIALE	SPACER, BEARING	ENTRETOISE ROULEMENTS	LAGERABSTANDHALTER	DISTANCIADOR COJINETES
	19	Z00062613	1	DADO FLANGIATO M20X1,5	NUT FLANGE M20X1.5	ECROU BRIDE M20X1,5	GEFLANSCHTE MUTTER M20X1,5	TUERCA CON REBORDE M20X1,5
	20	Z00019963	1	RONDELLA 30X20X1	WASHER 30X20X1	RONDELLE 30X20X1	SCHEIBE 30X20X1	ARANDELA 30X20X1
SMS125/11	21	8000H3865	1	CATENA 5/8X1/4-136	CHAIN 5/8X1/4-136	CHAINE 5/8X1/4-136	KETTE 5/8X1/4-136	CADENA 5/8X1/4-136
TE125/11	21	8000H3120	1	CATENA 5/8X1/4-138	CHAIN 5/8X1/4-138	CHAINE 5/8X1/4-138	KETTE 5/8X1/4-138	CADENA 5/8X1/4-138
SMS125/11	22	8000H6388	1	RUOTA POSTERIORE	WHEEL, REAR	ROUE ARRIERE	HINTERRAD	RUEDA TRASERA
TE125/11	22	8000H6390	1	RUOTA POSTERIORE	WHEEL, REAR	ROUE ARRIERE	HINTERRAD	RUEDA TRASERA

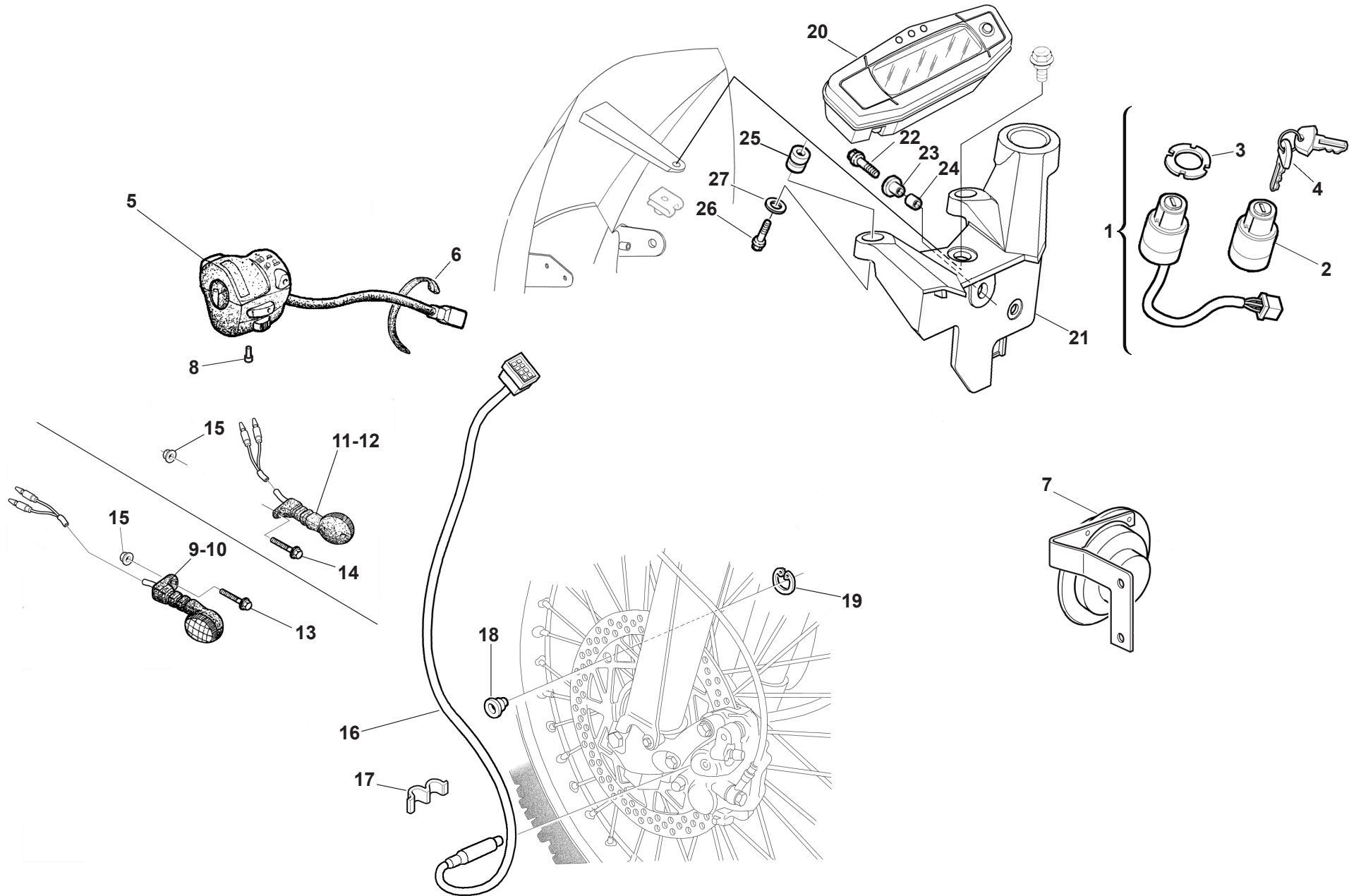

**STRUMENTO DIGITALE - DIGITAL INSTRUMENT  
INSTRUMENT DIGITAL - DIGITAL TACHOMETER  
INSTRUMENTO DIGITAL**

Note Notes Marke Notas	Pos. No. N. Index Pos.	N. Cod. Code No. Nr. Code Code Nr N. Cod.	Q.tà Q.ty Q.te M.ge C.ad	DENOMINAZIONE	NAME	DESIGNATION	BESHREIBUNG	DENOMINACION
	1	8000H2091	1	SERIE SERRATURE	LOCKS SET	JEU SERRURES	SCHLOSSSATZ	JUEGO CERRADURAS
	2	800043391	1	SERRATURA BLOCCASTERZO	LOCK, STEERING	ANTIVOL DIRECTION	SCHLOSS, LENKER	CARRADURA MANILLAR
	3	800074258	1	GHIERA COMMUTATORE A CHIAVE	RIM, MAIN SWITCH	CACHE COMMUTEUR	RING, ZUENDSCHALTER	VIROLA CONMUTADOR LLAVE
	4	800035531	2	CHIAVE GREZZA	KEY, BLANK	CLE PAS CRANTEE	SCHLUSSEL NICHT GEZACKT	LLAVE SEMIACABADA
	5	8000H1173	1	COMMUTATORE LUCI SINISTRO	HANDLE SWITCH, LEFT	COMMUTEUR FEUX GAUCHE	LINKER LENKERSCHALTER	CONMUTADOR LUCES IZQUERDO
	6	800071578	4	FASCETTA 78 MM	CLAMP 78 MM	COLLIER 78 MM	SCHELLE 78 MM	ABRAZADERA 78 MM
	7	8000H4696	1	AVVISATORE ACUSTICO	HORN	AVERTISSEUR SONORE	HUPE	BOCINA
	8	8000A1074	1	GOMMINO	GROMMET	CAOUTCHOUC	GUMMITEILE	GOMA
ARANCIO	9	8000A0227	1	LAMPEGGIATORE ANTERIORE DESTRO	FRONT FLASHER LIGHT RH	CLIGNOTANT AVANT DROITE	BLINKERLEUCHTE, VORNE RECHTS	INTERMITENTE DELANTERO DERECHO
BIANCO	9	8000H4688	1	LAMPEGGIATORE ANTERIORE DESTRO	FRONT FLASHER LIGHT RH	CLIGNOTANT AVANT DROITE	BLINKERLEUCHTE, VORNE RECHTS	INTERMITENTE DELANTERO DERECHO
ARANCIO	10	8000A0228	1	LAMPEGGIATORE ANTERIORE SINISTRO	FRONT FLASHER LIGHT LH	CLIGNOTANT AVANT GAUCHE	BLINKERLEUCHTE, VORNE LINKS	INTERMITENTE DELANTERO IZQUERDO
BIANCO	10	8000H4689	1	LAMPEGGIATORE ANTERIORE SINISTRO	FRONT FLASHER LIGHT LH	CLIGNOTANT AVANT GAUCHE	BLINKERLEUCHTE, VORNE LINKS	INTERMITENTE DELANTERO IZQUERDO
ARANCIO	11	8000A0229	1	LAMPEGGIATORE POSTERIORE DESTRO	REAR FLASHER LIGHT RH	CLIGNOTANT ARRIERE DROIT	BLINKERLEUCHTE, HINTEN RECHTS	INTERMITENTE TRASERO DERECHO
BIANCO	11	8000H4690	1	LAMPEGGIATORE POSTERIORE DESTRO	REAR FLASHER LIGHT RH	CLIGNOTANT ARRIERE DROIT	BLINKERLEUCHTE, HINTEN RECHTS	INTERMITENTE TRASERO DERECHO
ARANCIO	12	8000A0230	1	LAMPEGGIATORE POSTERIORE SINISTRO	REAR FLASHER LIGHT LH	CLIGNOTANT ARRIERE GAUCHE	BLINKERLEUCHTE, HINTEN LINKS	INTERMITENTE TRASERO IZQUERDO
BIANCO	12	8000H4691	1	LAMPEGGIATORE POSTERIORE SINISTRO	REAR FLASHER LIGHT LH	CLIGNOTANT ARRIERE GAUCHE	BLINKERLEUCHTE, HINTEN LINKS	INTERMITENTE TRASERO IZQUERDO
	13	Z00062727	2	VITE TE M6X1X16 CH8	SCREW TE M6X1X16 CH8	VIS TE M6X1X16 CH8	SCHRAUBE TE M6X1X16 CH8	TORNILLO TE M6X1X16 CH8
	14	Z00062728	2	VITE TEF M6X1X20 CH8	SCREW TEF M6X1X20 CH8	VIS TEF M6X1X20 CH8	SCHRAUBE TEF M6X1X20 CH8	TORNILLO TEF M6X1X20 CH8
	15	Z00044240	4	DADO AUTOBLOCCANTE M6X1 CH10	NUT, SELF LOCKING M6X1 CH10	ECROU AUTOBLOQUANT M6X1 CH10	SELBSTSPERRENDE MUTTER M6X1 CH10	TUERCA AUTOBLOQUEANTE M6X1 CH10
	16	8A0099652	1	SENSORE VELOCITA'	SENSOR, SPEED	CAPTEUR VITESSE	ABTASTER GESCHWINDIGKEIT	SENSOR VELOCIDAD
	17	8000A0664	3	MOLLETTA FERMACAVO	CLAMP, WIRING	COLLIER, CORDON	KABELKLEMME	GRAMPA CORDON
	18	800099775	1	MAGNETE	MAGNET	AIMANT	MAGNET	IMAN
	19	66N021200	1	ANELLO SEEGER	CIRCLIP	CIRCLIP	SEEGERRING	ANILLO SEEGER
	20	8000H3828	1	GRUPPO STRUMENTI	METER	GROUPE INSTRUMENTS	COCKPITINSTRUMENTE	TABLERO INSTRUMENTOS
	21	8000H0315	1	SUPPORTO STRUMENTI	BRACKET METER	SUPPORT TABLEAU BORD	HALTERUNG INSTRUMENTENBRETT	SOPORTE TABLERO INSTRUMENTOS
	22	Z00062730	1	VITE TE M6X1X30 CH8	SCREW TE M6X1X30 CH8	VIS TE M6X1X30 CH8	SCHRAUBE TE M6X1X30 CH8	TORNILLO TE M6X1X30 CH8
	23	8000H3017	1	BOCCOLA 14X8X6,25 H4	BUSH 14X8X6,25 H4	DOUILLE 14X8X6,25 H4	BUCHSE 14X8X6,25 H4	BUJE 14X8X6,25 H4
	24	8000H4032	1	DISTANZIALE	SPACER	ENTRETOISE	ABSTANDHALTER	DISTANCIADOR
	25	8000H0316	2	SILENTBLOCK	DAMPER	SILENTBLOC	SCHWINGUNGSDAEMPFER	CASQUILLO ELASTICO
	26	8A00H0534	2	VITE M5X12	SCREW M5X12	VIS M5X12	SCHRAUBE M5X12	TORNILLO M5X12
	27	62ND15548	2	RONDELLA 15X5,3X1	WASHER 15X5,3X1	RONDELLE 15X5,3X1	SCHEIBE 15X5,3X1	ARANDELA 15X5,3X1



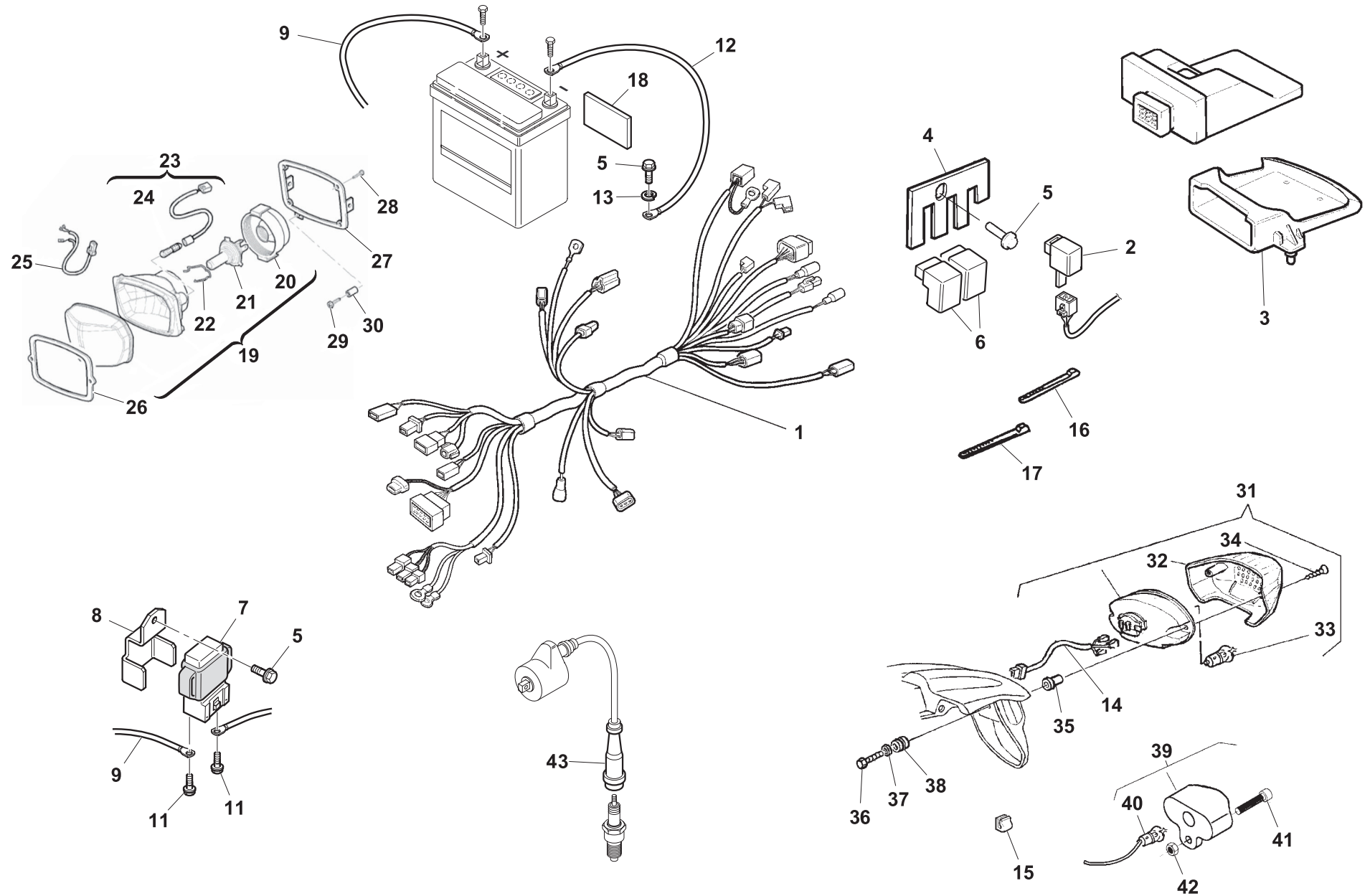



**GRUPPO CAVI, PARTI ELETTRICHE - MAIN WIRING HARNESS, ELECTRICAL PARTS -  
CABLES PRINCIPAL, PARTIES ELECTRIQUES - KABEL, ELEKTRISCHE KOMPONENTE -  
GRUPO PRINCIPAL CABLES, PARTES ELECTRICAS**

Note Notes Marke Notas	Pos. No. N. Index Pos.	N. Cod. Code No. Nr. Code Code Nr N. Cod.	Q.tà Q.ty Q.te M.ge C.ad	DENOMINAZIONE	NAME	DESIGNATION	BESHREIBUNG	DENOMINACION
	1	8000H3114	1	IMPIANTO ELETTRICO	WIRING HARNESS	FAISCEAU CABLES PRINCIPAL	HAUPTVERKABELUNG	GRUPO CABLES PRINCIPAL
	2	8000H1082	1	INTERMITTENZA LAMPEGGIATORI	FLASHER RELAY	RELAIS CLIGNOTANTS	BLINKERRELAIS	RELE INTERMITENTES
	3	8000H3804	1	SUPPORTO CENTRALINA CDI	BRACKET, IGNITER	SUPPORT UNITE' CONTROLE CDI	HALTER, STEUERGERAET CDI	SOPORTE CENTRAL CDI
	4	8000H3831	1	PIASTA SUPPORTO RELE'	BRACKET, RELAY	EQUERRE, RELAIS	KONSOLE RELAIS	SOPORTE RELE
	5	ZA0067997	3	VITE TEF M5X0,8X16 CH8	SCREW TEF M5X0.8X16 CH8	VIS TEF M5X0,8X16 CH8	SCHRAUBE TEF M5X0,8X16 CH8	TORNILLO TEF M5X0,8X16 CH8
	6	8000A6749	2	RELE'	RELAY	RELAIS	RELAIS	RELE
	7	8000H0809	1	TELERUTTORE AVVIAMENTO	RELAY, STARTING MOTOR	RELAIS DEMARRAGE	STARTRELAIS	RELE ARRANQUE
	8	8000H3882	1	SUPPORTO TELERUTTORE	HOLDER,MAGNETIC SWITCH	SUPPORT TELERUPTEUR	HALTER FERNSCHALTER	SOPORTE TELERUPTOR
	9	8000H3825	1	CAVO BATTERIA-TELERUTTORE	BATTERY-SOLENOID STARTER CABLE	CABLE BATTERIE-TELERUPTEUR	KABEL FUR BATTERIE-FERNCKONSOLE	CABLE BATERIA-TELERUPTOR
	10	8000H3826	1	CAVO MOTORINO AVVIAMENTO	CABLE BATTERY -STARTER RELAY	CABLE BATTERIE - TELERUPTEUR	BATTERIEKABEL - FERNSCHALTER	CABLE BATERIA - TELERRUPTOR
	11	ZS0067545	2	VITE TEF M6X1X8 CH8	SCREW TEF M6X1X8 CH8	VIS TEF M6X1X8 CH8	SCHRAUBE TEF M6X1X8 CH8	TORNILLO TEF M6X1X8 CH8
	12	8000H3827	1	CAVO MASSA BATTERIA	BATTERY GROUNDING CABLE	CABLE MASSE BATTERIE	BATTERIEMASSEKABEL	CABLE TIERRA BATERIA
	13	62N115535	1	RONDELLA ELASTICA 8,9X5,3X1	WASHER, SPRING 8.9X5.3X1	RONDELLE ELASTIQUE 8,9X5,3X1	FEDERSCHEIBE 8,9X5,3X1	ARANDELA ELASTICA 8,9X5,3X1
	14	8000A8497	1	CAVO FANALE POSTERIORE	CABLE, TAILLIGHT	CABLE FEU ARRIERE	KABELBAUM SCHLUSSLICHT	CABLE FARO PILOTO
	15	800072494	1	MOLLETTA FERMACAVO	CLAMP, WIRE	COLLIER, CORDON	KABELBINDER	GRAMPA CORDON
	16	800056444	12	FASCETTA 188 MM	CLAMP 188 MM	COLLIER 188 MM	SHELLE 188 MM	ABRAZADERA 188 MM
	17	800050005	3	FASCETTA	CLAMP	COLLIER	KLAMMER	ABRAZADERA
	18	800096739	1	PROTEZIONE ADESIVA	GUARD, ADHESIVE	PROTECTION ADHESIVE	KLEIBENSCHUTZ	PROTECCION ADHESIVA
	19	8000H1736	1	FANALE ANTERIORE	HEAD LIGHT	FEU AVANT	SCHEINWERFER	FARO DELANTERO
	20	8000H1775	1	CUFFIA PORTALAMPADA	COVER, SOCKET	COUVERCLE PORTE AMPOULE	FASSUNGABDECKUNG	CUBIERTA PORTA-LAMPARA
	21	8000H1774	1	LAMPADINA 12V 35/35W HS1	BULB 12V 35/35W HS1	AMPOULE 12V 35/35W HS1	GLHUELAMPE 12V 35/35W HS1	LAMPARA 12V 35/35W HS1
	22	8000H1773	1	MOLLETTA PORTALAMPADA	SPRING, SOCKET	RESSORT	FEDER	MUELLE
	23	800095886	1	PORTALAMPADA POSIZIONE	SOCKET, PILOT LIGHT	PORTE AMPOULE, LAMPE-TEMOIN	FASSUNG, KONTROLLAMPE	PORTA-LAMPARA
	24	800036230	1	LAMPADINA 12V 5W T10	WEDGE BASE BULB 12V5W T10	AMPOULE 12V 5W T10	GLUEHLAMPE 12V 5W T10	LAMPARA 12V 5W T10
	25	8000A6094	1	CAVO FANALE ANTERIORE	CORD, HEADLIGHT	CABLE FEU AVANT	VERKABELUNG SCHEINWERFER	CABLE FARO DELANTERO
	26	8000A1053	1	GUARNIZIONE FANALE ANTERIORE	DAMPER, HEADLIGHT	JOINT FEU	SCHEINWERFERDICHTUNG	JUNTA FARO
	27	8000A6484	1	SUPPORTO FANALE ANTERIORE	STAY, HEADLIGHT	SUPPORT FEU AVANT	KONSOLE, SCHEINWERFER	SOPORTE FARO DELANTERO
	28	Z000A6635	4	VITE	SCREW	VIS	SCHRAUBE	TORNILLO
	29	60ND02487	1	VITE TCEI M5X0,8X20	SCREW TCEI M5X0.8X20	VIS TCEI M5X0,8X20	SCHRAUBE TCEI M5X0,8X20	TORNILLO TCEI M5X0,8X20
	30	947200066	1	DISTANZIALE	TUBE	TUYAU	ROHRCHEN	MANGUITO
	31	8000A8494	1	FANALE POSTERIORE	TAIL LIGHT	FEU ARRIERE	SCHLUSSLICHT	LUZ COLA
	32	8A0094119	1	LENTE FANALE POSTERIORE	LENS, TAILLIGHT	CABOCHON FEU ARRIERE	RUCKLICHTGLAS	CRISTAL FARO TRASERO
	33	8A0018246	1	LAMPADINA 12V 5/21W	BULB 12V-5/21W	AMPOULE 12V 5/21W	GLUEHLAMPE 12V-5/21W	LAMPARA 12V 5/21W

